

Data sheet

2/2-way servo piston operated solenoid valve type EV245B



EV245B is a servo piston operated 2/2-way solenoid valve for use in steam application.

The servo piston operated design with PTFE seal on the main orifice and steel valve plate in the armature secures a reliable function and long life in steam applications.

Features and versions:

- Specifically designed for steam applications, 160 °C or 185 °C
- Differential pressure: 0.1 – 10 bar
- Media temperature from 0 – 185 °C
- Ambient temperature: Up to 40 °C
- Coil enclosure: IP65
- Thread connections: G ½ – G ¾
- DN 15 - 20
- Brass NC (normally closed)
 - EV245B used with BQ coil a.c. voltage up to 185 °C
 - EV245B used with BN coil d.c. voltage up to 160 °C
 - EV245B used with BB coil a.c. voltage up to 160 °C d.c. voltage up to 140 °C

Solenoid valve type EV245B, servo piston operated

Brass valve body, NC



Conne- ction ISO228/1	Seal mate- rial	Orifice size [mm]	k_v - value [m ³ /h]	Differential pressure min. to max. [bar]				Media temperature min. to max. [°C]			Code number
				Coil type BQ 10 W a.c.	Coil type BN 20 W d.c.	Coil type BB 10 W a.c.	Coil type BB 18 W d.c.	BQ	BN d.c. BB a.c.	BB d.c.	
G 1/2	PTFE	15	5.0	0.1 – 10	0.1 – 5	0.1 – 5	0.1 – 3.6	0 – 185	0 – 160	0 – 140	032U3833
G 3/4		20	6.0								032U3853

Technical data, NC

Main type	EV245B 15 – 20
Time to open [ms] ¹⁾	200
Time to close [ms] ¹⁾	2000

¹⁾ The times are indicative. The exact times will depend on the pressure conditions.

Installation	Vertical solenoid system is recommended		
Max. test pressure	25 bar		
Ambient temperature	Max. 40 °C at a medium temperature of 185 °C		
Viscosity	Max. 50 cSt		
Materials	Valve body / cover	Brass	EN 12165, CW 617N
	Armature / armature stop	Stainless steel	W. no. 1.4105 / AISI 430FR
	Armature tube	Stainless steel	W. no. 1.4306 / AISI 304L
	Springs	Stainless steel	W. no. 1.4310 / AISI 301
	Piston seal	PTFE	
	Piston ring	PTFE with grafito	
	Valve plate	Stainless steel	W. no. 1.4122
	External gasket	PTFE	

Dimensions and weight:

Type	Weight gross valve body with coil BQ, BB [kg]	Weight gross valve body with coil BN [kg]	L [mm]	B [mm]	H [mm]	H ₁ [mm]	H ₂ [mm]
EV245B 15B	0.75	1.03	62	46	98	13	85
EV245B 20B	0.72	1.00	62	46	98	13	85

Dimensions

Coil type BQ, BB

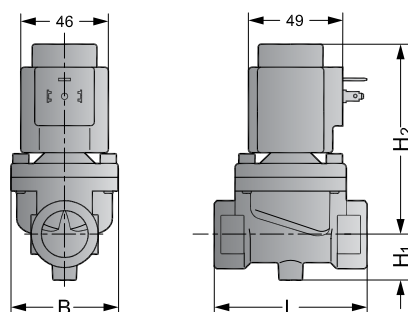

Coil type BN

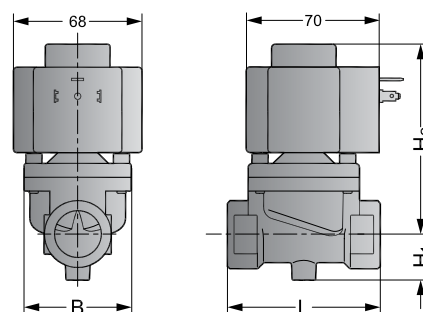

Solenoid valve type EV245B, servo piston operated

Coil type BQ a.c. Steam coil to 185 °C



Coil voltage	Voltage tolerances	Power consumption, inrush	Coil output [W]	Max media temperature [°C]	Coil appendix	Code number
24 V 50Hz	+10%, -15%	44 VA	10	185	16	018F4517
110 V 60Hz	+10%, -15%				20	018F4519
230 V 50Hz	+6%, -15%				31	018F4511
220 V 60Hz	+10%, -15%				29	018F4520

Coil type BN d.c. Steam coils to 160 °C



Coil voltage	Voltage tolerances	Power consumption, inrush	Coil output [W]	Max media temperature [°C]	Coil appendix	Code number
24 V d.c.	±10%	20 W	20	160	02	018F6968

Coil type BB a.c. Steam coils to 160 °C



Coil voltage	Voltage tolerances	Power consumption, inrush	Coil output [W]	Max media temperature [°C]	Coil appendix	Code number
24 V 50Hz	+10%, -15%	44 VA	10	160	16	018F7358
24 V 60Hz	+10%, -15%				14	018F7365
115 V 50Hz	+10%, -15%				22	018F7361
110 V 60Hz	+10%, -15%				21	018F7360
230 V 50Hz	+6%, -15%				31	018F7351
230 V 60Hz	+6%, -15%				32	018F7363
240 V 50Hz	+10%, -15%				33	018F7352
380 V 50Hz	+10%, -15%				37	018F7353

Type BB d.c. Steam coils to 140 °C

12 V d.c.	±10%	18 W	18	140	01	018F7396
24 V d.c.	±10%				02	018F7397

Technical data	Type BQ, BN, BB
Insulation of coil windings	Class H according to IEC 85
Connection	GDM 2011 (grey) Cable plug according to DIN 43650-A PG11
Coil enclosure, IEC 529	IP65
Ambient temperature	Max. 40 °C
Duty rating	Continuous

Accessories: Cable plug

Type	Code number
GDM 2011 (grey), cable plug according to DIN 43650-A PG11	042N0156

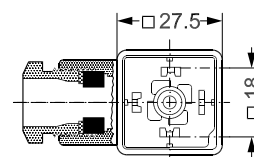
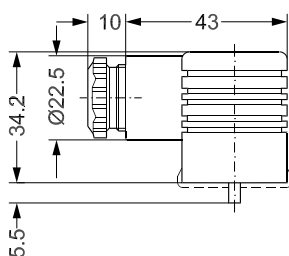

Solenoid valve type EV245B, servo piston operated

Spare part kits for EV245B 15-20

Type	Coil	Code number
EV245B	BQ, BN, BB, BR	032U3121
EV245B	BR	032U3129

The spare part kits comprises:

An assembled armature fitted on a piston
All gaskets and springs.

Clip on (BQ, BN, BB, BR):
Cover screws from top

Screw on (BR):
Cover screws from below

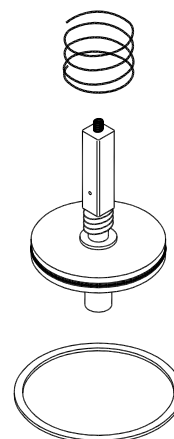
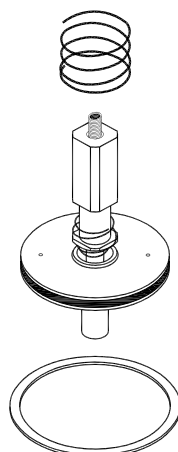
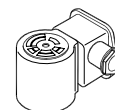
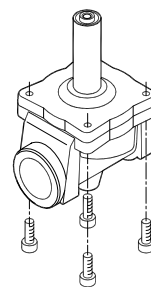
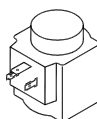
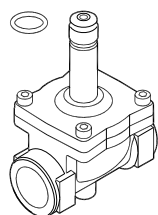

Solenoid valve type EV245B, servo piston operated

Function NC

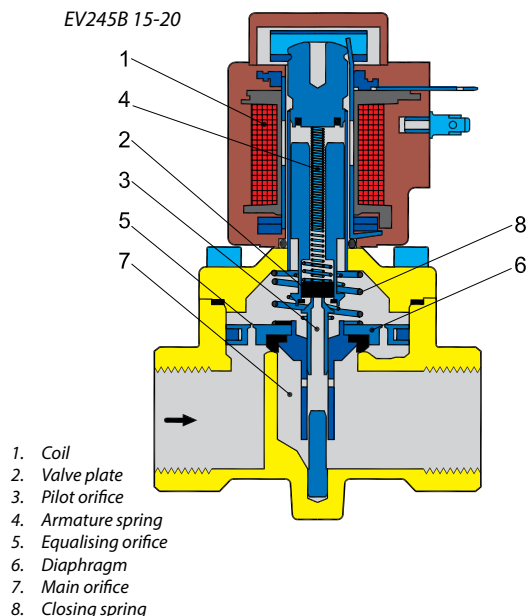

Coil voltage disconnected (closed):

When the voltage is disconnected, the valve plate (2) is pressed down against the pilot orifice (3) by the armature spring (4). The pressure across the piston (6) is built up via the equalising orifice (5). The piston closes the main orifice (7) as soon as the pressure across the piston is equivalent to the inlet pressure. The valve will be closed for as long as the voltage to the coil is disconnected.

Coil voltage connected (open):

When voltage is applied to the coil (1), the pilot orifice (3) is opened. As the pilot orifice is larger than the equalising orifice (5), the pressure across the piston (6) drops and therefore it is lifted clear of the main orifice (7). The valve is now open for unimpeded flow and will be open for as long as the minimum differential pressure across the valve is maintained, and for as long as there is voltage to the coil.

Steam capacity diagrams

Example
Capacity for EV245B 20 BD; inlet pressure (p_1) of 6 bar absolute; differential pressure at 1 bar: Approx. 100 kg/h / 80 kW

