



RADEX[®]-NC

Backlash-free, torsionally stiff and
maintenance-free steel laminae
couplings

type DK and EK
and their combinations

according to Standard 94/9/EC
(ATEX 95) for finish bored, pilot
bored and unbored couplings

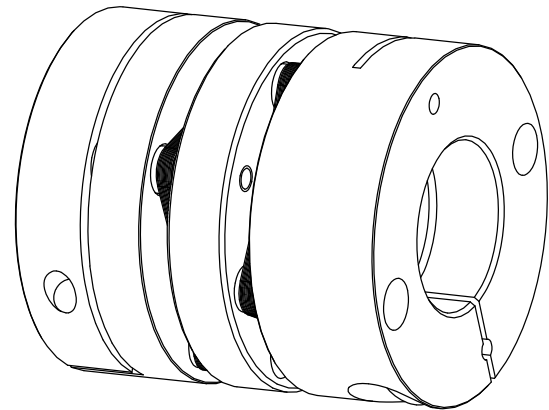

Type DK

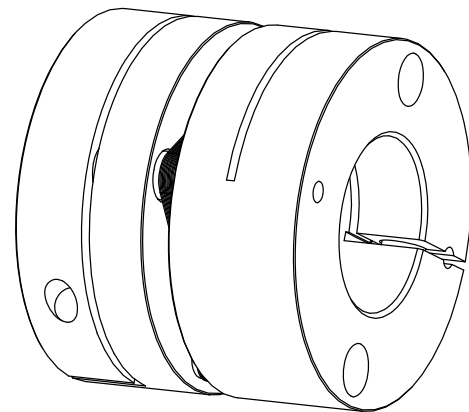

Type EK



The **RADEX[®]-NC** servo laminae coupling is a backlash-free, torsionally stiff and flexible steel laminae coupling. It has been developed particularly for the ranges of servo technology in order to meet the demands of high torsional stiffness (e. g. use in indexing tables, planet and worm gear pairs, ball roll spindles etc.).

Table of Contents

1 Technical Data

2 Hints

- 2.1 Coupling Selection
- 2.2 General Hints
- 2.3 Safety and Advice Hints
- 2.4 General Hints to Danger
- 2.5 Proper Use





3 Storage

4 Assembly

- 4.1 Components of the Couplings
- 4.2 Hint regarding the Finish Bore
- 4.3 Assembly of the Hubs
- 4.4 Displacements - Alignment of the Couplings
- 4.5 Spares Inventory, Customer Service Addresses

5 Enclosure A

Hints and instructions regarding the use in  hazardous areas

- 5.1 Use in  Hazardous Areas According to the Regulations
- 5.2 Control intervals for couplings in  hazardous areas
- 5.3 Approximate Values of Wear
- 5.4 Permissible coupling materials in the  hazardous area
- 5.5  Marking of coupling for the hazardous area
- 5.6 Starting
- 5.7 Breakdowns, causes and elimination
- 5.8 EC Certificate of Conformity according to the EC Standards 94/9/EC dated 23 March 1994



1 Technical Data

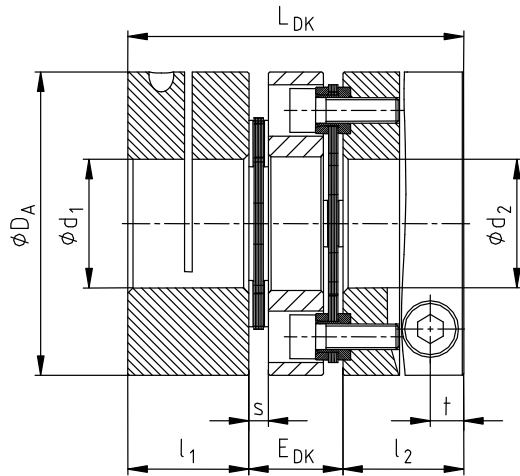

picture 1: RADEX®-NC type DK

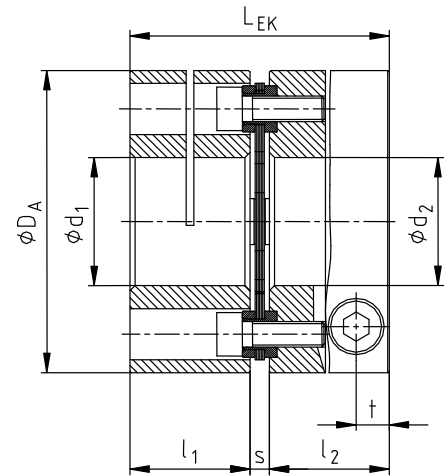

picture 2: RADEX®-NC type EK

Table 1: Dimensions

RADEX®-NC size	Dimensions [mm]								Clamping screw DIN EN ISO 4762	
	max. d ₁ , d ₂	D _A	l ₁ , l ₂	L _{DK}	E _{DK}	L _{EK}	s	t	M	T _A [Nm]
5	10	26	12	34	10	26,5	2,5	3,5	M2,5	0,8
10	15	35	16	44	12	35	3	5,0	M4	3
15	20	47	21	55	13	45	3	6,8	M6	10
20	25	59	24	68	20	53	5	6,5	M6	10
25	35	70	32	88	24	69	5	9,0	M8	25
35	40	84	35	98	28	77	7	10,5	M10	49
42	55	104	40	116	36	91	11	10,5	M10	69

Table 2: Technical data

RADEX®-NC size	Technical data						
	T _{KN} [Nm]	T _{K max.} [Nm]	Max. speed [1/min]	Torsional rigidity [Nm/rad]		Mass moment of inertia [kgm ²]	
				Type DK	Type EK	Type DK	Type EK
5	2,5	5	25000	1200	2400	0,000004	0,000003
10	7,5	15	20000	2800	5600	0,000014	0,00001
15	20	40	16000	6000	12000	0,000054	0,00004
20	30	60	12000	15000	30000	0,00019	0,00015
25	60	120	10000	30000	60000	0,00046	0,00035
35	100	200	9000	36000	72000	0,0010	0,0008
42	180	360	7000	60000	120000	0,0075	0,0062



RADEX®-NC couplings with attached parts that can generate heat, sparks and static charging (e. g. combinations with brake drums, brake disks, overload systems like torque limiters, impellers etc.) are not allowed for the use in hazardous areas. A separate checking must be made.

Schutzvermerk ISO 16016 beachten.	Gezeichnet: 26.03.09 Pz	Ersatz für: KTR-N vom 16.01.03
	Geprüft: 01.04.09 Pz	Ersetzt durch:



1 Technical Data

Table 3: Transmittable torque of the clamping hub

RADEX®-NC size	5	10	15	20	25	35	42
Clamping screw M	M2,5	M4	M6	M6	M8	M10	M10
Tightening torque T _A [Nm]	0,8	2,9	10	10	25	49	69
Bores and the corresponding transmittable torque of the clamping hub [Nm]							
Pilot bored	2,5	4,5	5,5	7,5	9,5	11,5	15,0
Ø 3	2,2						
Ø 5	2,3	8					
Ø 8	2,4	9					
Ø 10	2,5	10	28				
Ø 12		10	30	36			
Ø 14		11	31	37			
Ø 15		11	32	38	82		
Ø 16			32	39	83		
Ø 19			34	40	87	155	
Ø 20			35	41	88	157	
Ø 24				44	93	165	285
Ø 25				45	94	167	287
Ø 28					98	173	296
Ø 30					100	177	301
Ø 32					103	181	307
Ø 35					106	187	315
Ø 38						193	323
Ø 40						197	329
Ø 45							343
Ø 50							357
Ø 55							370



PRECAUTION!

Clamping hubs without feather key may be used in category 3 only.



ATTENTION!

Selection of clamping hubs

With the use in explosion-proof areas the clamping hubs have to be selected in a way that the difference between the peak torque of the machine including all operation parameters and the frictionally engaged torque of the clamping ring hub is at least a service factor of $s = 2$.

2 Hints

2.1 Coupling Selection



CAUTION!

For a continuous and troublefree operation of the coupling it must be designed according to the selection instructions (according to DIN 740 part 2) for the particular application (see RADEX®-NC catalogue).

If the operating conditions (performance, speed, changes at engine and machine) change, the coupling selection must be checked again.

Please make sure that the technical data regarding torque only refers to the laminae packages. The transmissible torque of the shaft/hub connection must be checked by the orderer, and he is responsible for the same.

For drives with endangered torsional vibration (drives with periodical load on torsional vibration) it is necessary to make a torsional vibration calculation to ensure a perfect selection. Typical drives with endangered torsional vibration are e. g. drives with diesel engines, piston pumps, piston compressors etc. On request KTR makes the coupling selection and the torsional vibration calculation.

Schutzvermerk ISO 16016 beachten.	Gezeichnet: 26.03.09 Pz	Ersatz für: KTR-N vom 16.01.03
	Geprüft: 01.04.09 Pz	Ersetzt durch:



2 Hints

2.2 General Hints

Please read through these mounting instructions carefully before you set the coupling into operation. Please pay special attention to the safety instructions!



The **RADEX®-NC** coupling is suitable and approved for the use in hazardous areas. When using the coupling in hazardous areas please observe the special hints and instructions regarding safety in enclosure A.

The mounting instructions are part of your product. Please keep them carefully and close to the coupling. The copyright for these mounting instructions remains with **KTR Kupplungstechnik GmbH**.

2.3 Safety and Advice Hints



DANGER! Danger of injury to persons.



CAUTION! Damages on the machine possible.



ATTENTION! Pointing to important items.



PRECAUTION! Hints concerning explosion protection.

2.4 General Hints to Danger



DANGER! With assembly, operation and maintenance of the coupling it has to be made sure that the entire drive train is secured against unintentional engagement. You can be seriously hurt by rotating parts. Please make absolutely sure to read through and observe the following safety instructions.

- All operations on and with the coupling have to be performed taking into account „safety first“.
- Please make sure to disengage the drive unit and the power packs in service before you perform your work.
- Secure the drive unit against unintentional engagement, e.g. by providing hints at the place of engagement or removing the fuse for current supply.
- Do not touch the operation area of the coupling as long as it is in operation.
- Please secure the coupling against unintentional touch. Please arrange for the corresponding protection devices and caps.

2.5 Proper Use

You may only assemble, operate and maintain the coupling if you

- carefully read through the mounting instructions and understood them
- had technical training
- are authorized to do so by your company

The coupling may only be used in accordance with the technical data (see table 1 to 3 in chapter 1). Unauthorized modifications on the coupling design are not admissible. We do not take any warranty for resulting damages. To further develop the product we reserve the right for technical modifications.

The **RADEX®-NC coupling** described in here corresponds to the technical status at the time of printing of these mounting instructions.

Schutzvermerk ISO 16016 beachten.	Gezeichnet: 26.03.09 Pz	Ersatz für: KTR-N vom 16.01.03
	Geprüft: 01.04.09 Pz	Ersetzt durch:



3 Storage

The coupling hubs are supplied in preserved condition and can be stored at a dry and roofed place for 6 - 9 months.



CAUTION!

Humid storage rooms are not suitable.

Please make sure that there is no condensation. The best relative air humidity is under 65%.

4 Assembly

The coupling is generally delivered in assembled condition. Before assembly the coupling has to be controlled for completeness.

4.1 Components of the Couplings

Components of RADEX®-NC type DK

Component	Quantity	Designation	Component	Quantity	Designation
1	2	Clamping hub	4	8	Cap screws DIN EN ISO 4762
2	2	Laminae package	5	2	Cap screws DIN EN ISO 4762
3	1	Spacer			

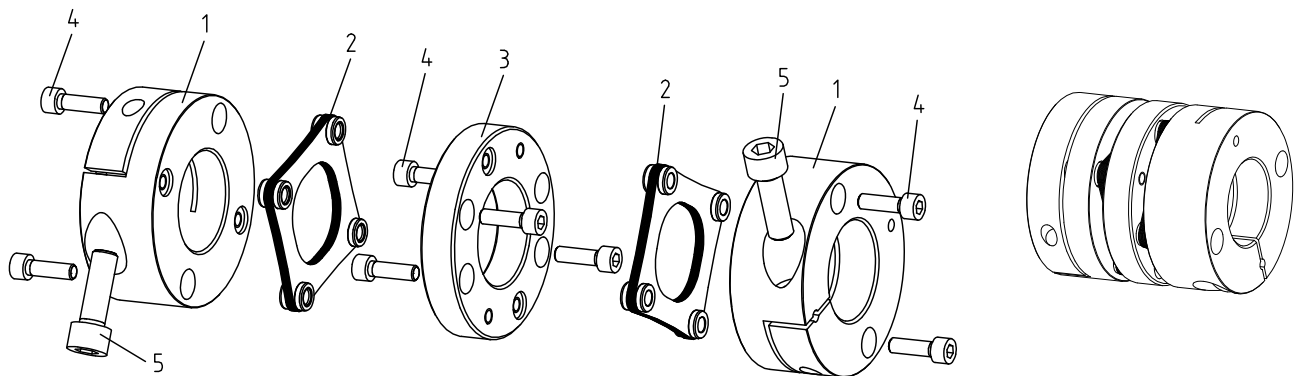

picture 3: RADEX®-NC type DK

Components of RADEX®-NC type EK

Component	Quantity	Designation	Component	Quantity	Designation
1	2	Clamping hub	3	4	Cap screws DIN EN ISO 4762
2	1	Laminae package	4	2	Cap screws DIN EN ISO 4762

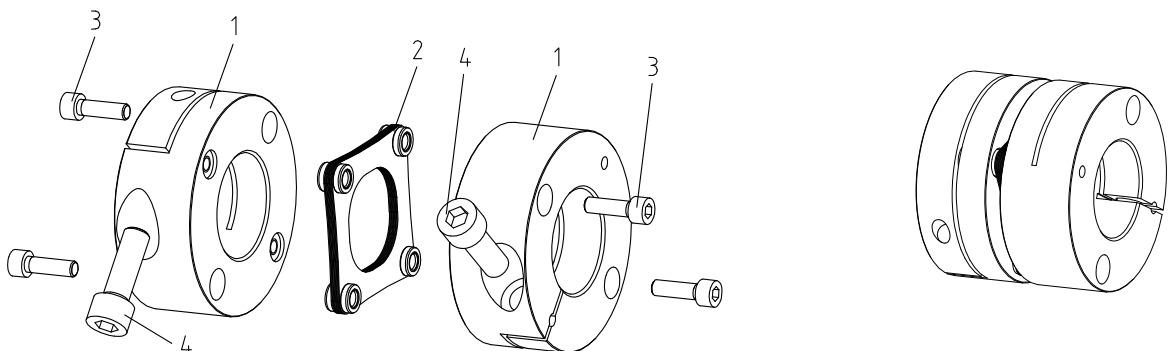

picture 4: RADEX®-NC type EK

Schutzvermerk ISO 16016 beachten.	Gezeichnet: 26.03.09 Pz	Ersatz für: KTR-N vom 16.01.03
	Geprüft: 01.04.09 Pz	Ersetzt durch:



4 Assembly

4.2 Hint Regarding the Finish Bore



DANGER!

The maximum permissible bore diameters d (see table 1 to 3 in chapter 1 - Technical Data) must not be exceeded. If these figures are disregarded, the coupling may tear. Rotating particles may cause serious danger.

- Clamping hub bores machined by the customer have to observe concentric running or axial running, respectively (see picture 10).
- Please make absolutely sure to observe the figures for d_{max} .
- Carefully align the clamping hubs when the finish bores are brought in.

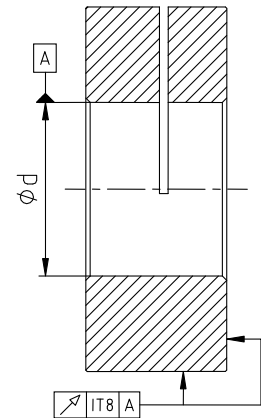

picture 5: concentric running and axial running



CAUTION!

The orderer is responsible for all subsequently made machinings to unbored or pilot bored and to finish machined coupling parts and spare parts. KTR does not assume any warranty claims resulting from insufficient refinish.



PRECAUTION!

Any mechanical rework to couplings that are used in hazardous areas require an explicit release by KTR. The orderer must send a drawing to KTR acc. to which the manufacture must be made. KTR checks this drawing and returns it to the orderer with approval. KTR supplies unbored or pilot bored coupling parts and spare parts on explicit customer's request. These parts are additionally labelled with the symbol

4.3 Assembly of the Hub



ATTENTION!

We recommend to check bores, shaft, keyway and feather key for dimensional accuracy before assembly.

Heating the hubs slightly (approx. 80 °C) allows for an easier installation onto the shaft.



PRECAUTION!

Please pay attention to the danger of ignition in hazardous areas.



DANGER!

Touching the heated hubs causes burns. We would recommend to wear safety gloves.



CAUTION!

During the assembly please make sure that the E_{DK} or s dimension (see table 1) is observed, so that the coupling parts do not contact each other during the operation. Disregarding this hint may cause damage on the coupling.

Schutzvermerk ISO 16016 beachten.	Gezeichnet: 26.03.09 Pz Geprüft: 01.04.09 Pz	Ersatz für: KTR-N vom 16.01.03 Ersetzt durch:
--------------------------------------	---	--



4 Assembly

4.3 Assembly of the Hub

The power transmission of the **RADEX®-NC** coupling is effected frictionally engaged by clamping hubs.

During assembly please pay attention to the following procedures:

- Clean and degrease the hub bores and the shaft ends.
- Release the clamping screws slightly.
- Insert the shaft ends of the driving and the driven machine into the hubs of the **RADEX®-NC** coupling.
- Displace the driving and the driven machine in axial direction until reaching dimension E_{DK} or s. If the aggregates have already been fixed, the E_{DK} or s dimension can be adjusted by axial displacement of the hubs onto the shafts.



ATTENTION!

Please make sure that the laminae packages are assembled as shown in picture 6. The sleeves of the package must be inserted in the hollows of the hub or of the spacer. The screw head is on the disks of the package. For tightening torques T_A of the screws of the laminae package see table 4.

Table 4: Tightening torques of the screws of the laminae package

RADEX®-NC size	5	10	15	20	25	35	42
Screw size	M2,5	M3	M4	M5	M6	M6	M8
Tightening torque T_A [Nm]	1,1	1,9	4,1	8,5	14	14	35

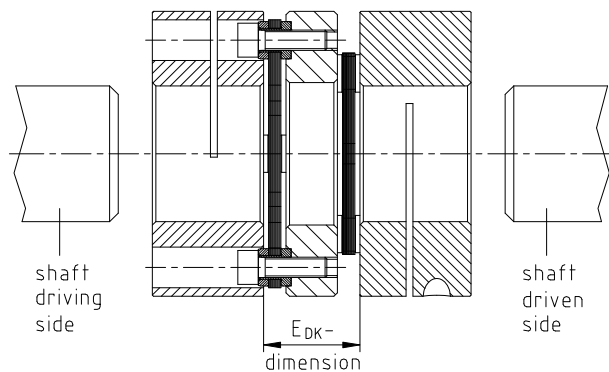

picture 6: assembly of the coupling

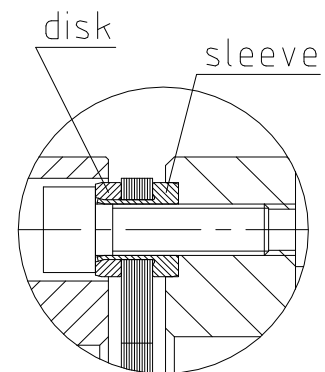

picture 7: assembly of the laminae package

Tabelle 5: Drawing for assembly

RADEX®-NC size	Drawing for assembly		RADEX®-NC size	Drawing for assembly	
	Type DK	Type EK		Type DK	Type EK
5	Z 409445	Z 409456	25	Z 390312	Z 391674
10	Z 391668	Z 391671	35	Z 391670	Z 391675
15	Z 390408	Z 391672	42	Z 388611	Z 388610
20	Z 391669	Z 391673			



4 Assembly

4.3 Assembly of the Hub

Continuation:



CAUTION!

During the assembly please make sure that the E_{DK} or s dimension (see table 3) is observed, so that the coupling will be assembled free from distortion in axial direction. In case of non-observance, the coupling may be damaged.

- Tighten the clamping screws of the hub with the tightening torque T_A indicated in table 1.



CAUTION!

The frictionally engaged and transmittable torques of the clamping hubs are dependent on the bore diameter (see table 3).



PRECAUTION!

Clamping hubs without feather key may be used in category 3 only.



ATTENTION!

Selection of clamping hubs

With the use in explosion-proof areas the clamping hubs have to be selected in a way that the difference between the peak torque of the machine including all operation parameters and the frictionally engaged torque of the clamping ring hub is at least a service factor of $s = 2$.

4.5 Displacements - Alignment of the Couplings

The values of displacement indicated in table 6 offer safety in order to compensate for external influences like e. g. heat expansions, inaccuracies in manufacture etc.



CAUTION!

In order to ensure a long lifetime of the coupling and to avoid dangers regarding the use in hazardous areas, the shaft ends must be accurately aligned.



Please absolutely observe the displacement figures indicated (see table 6). If the figures are exceeded, the coupling is damaged.

The exacter the alignment of the coupling, the higher is its lifetime.

In case of a use in hazardous areas for the explosion group IIC (marking II 2GD c IIC T X), only the half displacement figures (see table 6) are permissible.

Please note:

- The displacement values shown in table 6 are maximum figures which must not appear at the same time. With radial, axial and angular displacement arising at the same time these values have to be reduced (see picture 9).
- Please control with a dial gauge, ruler or feeler whether the permissible displacement values of table 6 are adhered to.

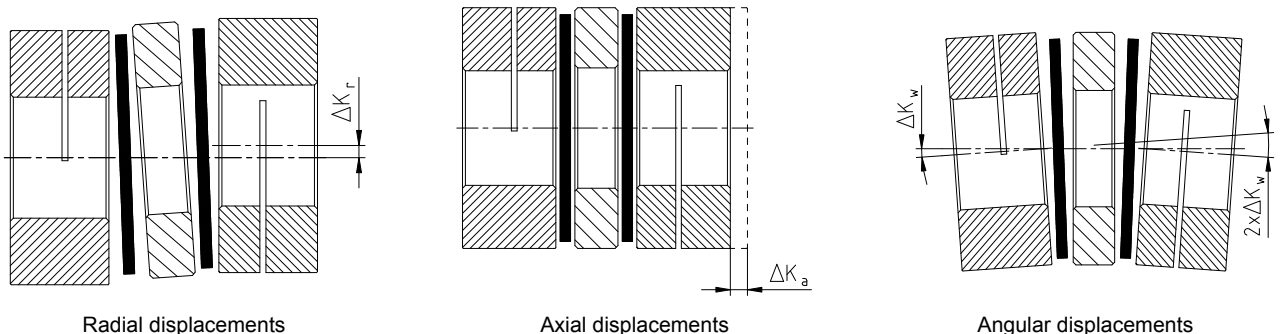

picture 8: displacements

Schutzvermerk ISO 16016 beachten.	Gezeichnet: 26.03.09 Pz	Ersatz für: KTR-N vom 16.01.03
	Geprüft: 01.04.09 Pz	Ersetzt durch:



4 Assembly

4.5 Displacements - Alignment of the Couplings

Table 6: Displacement values

Size	Type DK			Type EK		
	ΔK_r [mm] (radial)	ΔK_a [mm] (axial)	$\Delta K_w^{1)}$ [degree] (angular)	ΔK_r [mm] (radial)	ΔK_a [mm] (axial)	$\Delta K_w^{1)}$ [degree] (angular)
5	0,10	0,4	1	-	0,2	1
10	0,14	0,8	1	-	0,4	1
15	0,16	1,0	1	-	0,5	1
20	0,25	1,2	1	-	0,6	1
25	0,30	1,6	1	-	0,8	1
35	0,40	2,0	1	-	1,0	1
42	0,50	2,8	1	-	1,4	1

1) each laminae package

Examples for the combinations of displacements shown in picture 9:

Example 1:

- $\Delta K_r = 10\%$
- $\Delta K_w = 80\%$
- $\Delta K_a = 10\%$

Example 2:

- $\Delta K_r = 30\%$
- $\Delta K_w = 30\%$
- $\Delta K_a = 40\%$

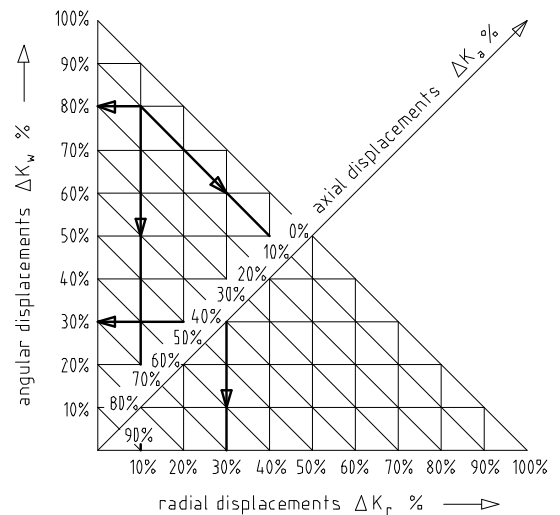

picture 9: combination of displacements

$$\Delta K_{total} = \Delta K_a + \Delta K_r + \Delta K_w \leq 100 \%$$

4.6 Spares Inventory, Customer Service Addresses

A basic requirement to guarantee the operational readiness of the coupling is a stock of the most important spare parts on site.

Contact addresses of the KTR partners for spare parts and orders can be obtained from the KTR homepage under www.ktr.com.



5 Enclosure A

Hints and instructions regarding the use in  hazardous areas

Type DK: clamping hub / laminae package / spacer / laminae package / clamping hub
Type EK: clamping hub / laminae package / clamping hub

5.1 Selection of the Coupling Size

If the coupling is used in explosion proof areas, the size must be selected in a way that there is a minimum safety of $s = 2,0$ from the unit torque to the nominal torque of the coupling.

5.2 Use in Hazardous Areas According to the Regulations

Conditions of operation in  hazardous locations

RADEX®-NC couplings are suitable for the use according to EC standard 94/9/EC.

1. Industry (with the exception of mining)

- device class II of category 2 and 3 (*coupling is not approved for device class 1*)
- media class G (*gases, fogs, steams*), zone 1 and 2 (*coupling is not approved for zone 0*)
- media class D (*dusts*), zone 21 and 22 (*coupling is not approved for zone 20*)
- explosion class IIC (*explosion class IIA and IIB are included in IIC*)

Temperature class:

Temperature class	Ambient temperature	Max. surface temperature ¹⁾
T2, T1	- 30 °C to + 200 °C	210 °C ²⁾
T3	- 30 °C to + 190 °C	200 °C ²⁾
T4	- 30 °C to + 125 °C	135 °C ²⁾
T5	- 30 °C to + 90 °C	100 °C
T6	- 30 °C to + 75 °C	85 °C

Explanation:

The maximum surface temperatures result from each the maximum permissible ambient or operating temperature T_a plus the maximum temperature increase ΔT of 10 K which has to be taken into account.

¹⁾ The ambient or operating temperature T_a , respectively, is limited to + 200 °C by the permissible permanent operating temperature.

²⁾ The maximum surface temperature of 110 °C applies for the use in locations which are potentially subject to dust explosion, too.

2. Mining

Device class I of category M2 (*coupling is not approved for device category M1*).
Permissible ambient temperature - 30 °C to + 140 °C.

Schutzvermerk ISO 16016 beachten.	Gezeichnet: 26.03.09 Pz	Ersatz für: KTR-N vom 16.01.03
	Geprüft: 01.04.09 Pz	Ersetzt durch:



5 Enclosure A

Hints and instructions regarding the use in  hazardous areas

5.3 Control intervals for couplings in  hazardous areas

Explosion group	Control intervals
3G 3D	For couplings which are classified in category 3G or 3D the operating and assembly instructions that are usual for standard operation apply. During the standard operation which has to be subject to the analysis of danger of ignition the couplings are free from any ignition source. Merely the temperature increase produced by proper heating and depending on the coupling type has to be considered: for RADEX®-NC: $\Delta T = 10 \text{ K}$
II 2GD c IIB T2, T3, T4, T5, T6	A checking of the circumferential backlash and a visual check of the laminae package must be effected after 3,000 operating hours for the first time, after 6 months at the latest. Except for centered, stiff connecting flanges (e. g. bellhousings). If you note an unconsiderable or no wear at the laminae package after this first inspection, the further inspections can be effected, in case of the same operating parameters, respectively after 6,000 operating hours or after 18 months at the latest. If you note a considerable wear during the first inspection, so that a change of the laminae package would be recommended, please find out the cause according to the table „Breakdowns“, as far as possible. The maintenance intervals must be adjusted according to the changed operating parameters.
II 2GD c IIC T2, T3, T4, T5, T6	A checking of the circumferential backlash and a visual check of the laminae package must be effected after 2,000 operating hours for the first time, after 3 months at the latest. Except for centered, stiff connecting flanges (e. g. bellhousings). If you note an unconsiderable or no wear at the laminae package after this first inspection, the further inspections can be effected, in case of the same operating parameters, respectively after 4,000 operating hours or after 12 months at the latest. If you note a considerable wear during the first inspection, so that a change of the laminae package would be recommended, please find out the cause according to the table „Breakdowns“, as far as possible. The maintenance intervals must be adjusted according to the changed operating parameters.

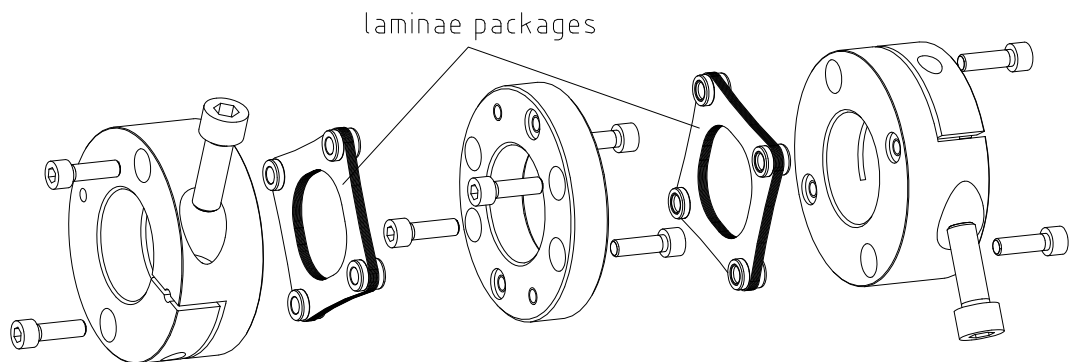

picture 10: RADEX®-NC

Schutzvermerk ISO 16016 beachten.	Gezeichnet: 26.03.09 Pz	Ersatz für: KTR-N vom 16.01.03
	Geprüft: 01.04.09 Pz	Ersetzt durch:



5 Enclosure A

Hints and instructions regarding the use in  hazardous areas

5.4 Visual Check and Measures

During the visual control the laminae packages must be checked concerning cracks and detached screws. Detached screws must be tightened with the screw tightening torque to be observed (see table 10). Laminae packages and screws showing cracks must be exchanged immediately, irrespective of the inspection intervals.



For the applications in hazardous areas all screw connections have to be secured against self-slackening additionally, e. g. by gluing with Loctite (medium-tight).

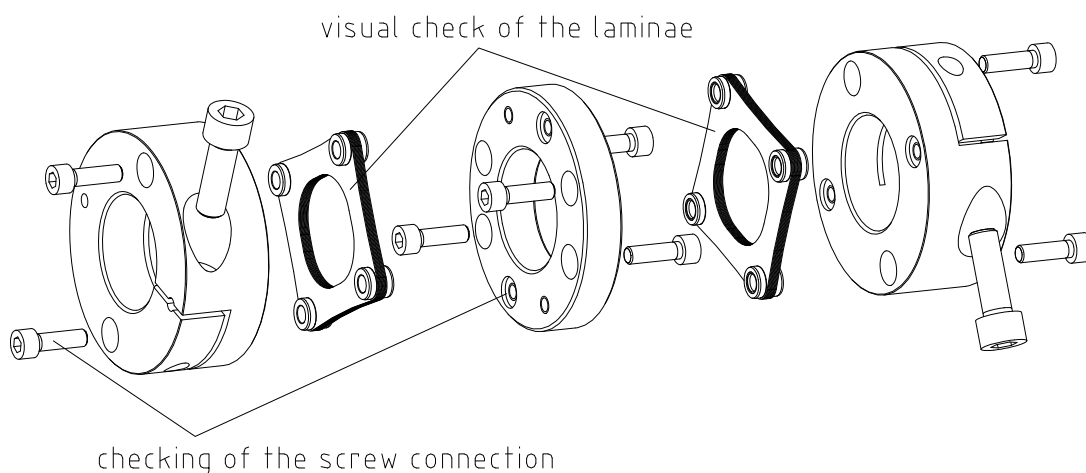

picture 11: RADEX®-NC



CAUTION!

In order to ensure a long lifetime of the coupling and to avoid dangers regarding the use in hazardous areas, the shaft ends must be accurately aligned. Please absolutely observe the displacement figures indicated (see table 11). If the figures are exceeded, the coupling is damaged.

5.5 Permissible coupling materials in the hazardous area

In the Explosion Groups **IIA**, **IIB** and **IIC** the following materials may be combined:

- Steel
- Stainless steel

Semifinished products from aluminium with a magnesium part of up to 7,5 % and a yield point of $R_{p0,2} \geq 250 \text{ N/mm}^2$ are permitted for the use in hazardous areas.

Aluminium diecast is generally excluded for hazardous areas.

Schutzvermerk ISO 16016 beachten.	Gezeichnet: 26.03.09 Pz	Ersatz für: KTR-N vom 16.01.03
	Geprüft: 01.04.09 Pz	Ersetzt durch:



5 Enclosure A

Hints and instructions regarding the use in  hazardous areas

5.6 Marking of coupling for the hazardous area

Couplings for the use in hazardous areas are marked on at least one component completely and on the remaining components at the outside diameter of the hub or on the front side with an  label for the respectively permitted conditions of use. The laminae packages are excluded.

Complete labelling:



II 2G c IIC T6, T5, T4, T3 bzw. T2 - 30 °C ≤ T_a ≤ + 75 °C, + 90 °C,
+ 125 °C, + 190 °C bzw. + 200 °C
II 2D c T 110 °C - 30 °C ≤ T_a ≤ + 100 °C / I M2 c - 30 °C ≤ T_a ≤ + 140 °C

Short labelling:



II 2GD c IIC T X/I M2 c X

The former marking
remains valid:



II 2G c IIC T5/T6 -20°C ≤ T_a ≤ +80/65°C
II 2D c T110°C/I M2 c -20°C ≤ T_a ≤ +80°C

The labelling with Explosion Group IIC includes the Explosion Groups IIA and IIB.

If the coupling part is labelled with  in addition to , KTR supplied it unbored or pilot bored.



CAUTION!

Any mechanical rework to couplings that are used in hazardous areas require an explicit release by KTR.

The orderer must send a drawing to KTR acc. to which the manufacture must be made. KTR checks this drawing and returns it to the orderer with approval.

5.7 Starting

Before putting the coupling into operation, check the tightness of the setscrews in the hubs, the alignment and the distance dimension E and correct, if necessary, and also check all screw connections regarding the stipulated tightening torques dependent on the type of coupling.



If used in hazardous areas the setscrews to fix the hub as well as all screw connections must be additionally secured against self-loosening, e. g. glue with Loctite (medium strength).

Last but not least, the coupling protection against unintended contact must be fixed.

The cover must be electrically conductive and be included in the equipotential bonding. Bellhousings (magnesium part below 7,5 %) made from aluminium and damping rings (NBR) can be used as connecting element between pump and electro motor. The cover may only be taken off after having stopped the unit.

During operation, please pay attention to

- strange running noises
- occurring vibrations.

If the couplings are used in dust explosive areas and in mining the user must make sure that there is no accumulation of dust in a critical quantity between the cover and the coupling. The coupling must no operate in an accumulation of dust.

Schutzvermerk ISO 16016 beachten.	Gezeichnet: 26.03.09 Pz	Ersatz für: KTR-N vom 16.01.03
	Geprüft: 01.04.09 Pz	Ersetzt durch:



5 Enclosure A

Hints and instructions regarding the use in  hazardous areas

5.7 Starting

For covers with unlocked openings on the upper side no light metals may be used if the couplings are used as appliances of appliance group II (*if possible, from stainless steel*).

If the couplings are used in mining (appliance group I M2), the cover must not be made from light metal. In addition, it must be resistant to higher mechanical loads than if it is used as appliance of appliance group II.

The minimum distance of the protection device to the rotating parts must be at least 5mm.

If the protection device is used as cover, regular openings complying with the explosion protection demands can be made that must not exceed the following dimensions:

	Form of the openings		
	Circular openings diameter in mm	Rectangular openings side length in mm	Straight or bended slot distance of the side limit in mm
Top surface of the covering	4	4	Prohibited
Side parts of the covering	8	8	8



CAUTION!

If you note any irregularities at the coupling during operation, the drive unit must be turned off immediately. The cause of the breakdown must be found out with the table „Breakdowns“ and, if possible, be eliminated according to the proposals. The possible breakdowns mentioned can be hints only. To find out the cause all operating factors and machine components must be considered.

Coupling layer:



If coated (priming, painting etc.) couplings are used in hazardous areas, the requirements to conductability and layer thickness must be considered. In case of paintings up to 200 µm no electrostatic load can be expected. Multiple coatings that are thicker than 200 µm are prohibited for explosion group IIC.

5.8 Breakdowns, Causes and Elimination

The below-mentioned errors can lead to an incorrect use of the **RADEX®-NC** coupling. In addition to the stipulations in these operating and mounting instructions please make sure to avoid these errors.

The errors listed can only be clues to search for the errors. When searching for the error the adjacent components must be generally included.



Due to incorrect use the coupling can become a source of ignition. EC Standard 94/9/EC requires a special care from the manufacturer and the user.

General errors incorrect use:

- Important data for the coupling selection was not forwarded.
- The calculation of the shaft/hub connection was not considered.
- Coupling parts with damage occurred during transport are assembled.
- If the heated hubs are assembled, the permissible temperature is exceeded.
- The fits of the parts to be assembled are not coordinated with each other.
- Tightening torques are below/exceeded.
- Components are exchanged by mistake/put together incorrectly.
- A wrong or no laminae package is inserted into the coupling.

Schutzvermerk ISO 16016 beachten.	Gezeichnet: 26.03.09 Pz Geprüft: 01.04.09 Pz	Ersatz für: KTR-N vom 16.01.03 Ersetzt durch:
--------------------------------------	---	--



5 Enclosure A

Hints and instructions regarding the use in  hazardous areas

5.8 Breakdowns, Causes and Elimination

Continuation:

- No original KTR parts (purchased parts) are used.
- The coupling used/the coupling protection used is not suitable for the operation in hazardous areas and does not correspond to EC Standard 94/9/EC, respectively.
- Maintenance intervals are not observed.

Breakdowns	Causes	Danger hints for hazardous areas	Elimination
Change of the running noises and / or occurring vibrations	Misalignment	---	1) The unit out of operation 2) Eliminate the reason for the misalignment (e. g. loose foundation bolts, break of the engine fixing, heat expansion of unit components, change of the assembly dimension E of the coupling) 3) Checking of wear see under point Control
	Loose shoulder bolts, low micro friction under the screw head and at the steel laminae package	Danger of ignition due to hot surfaces	1) Put the unit out of operation 2) Check coupling parts and exchange damaged coupling parts 3) Tighten the shoulder bolts until reaching the permissible tightening torque 4) Check alignment, correct if necessary
	Loose screws for axial securement of flange hubs	---	1) Put the unit out of operation 2) Check alignment of coupling 3) Tighten the screws to secure the flange hubs and secure against self-loosening 4) Checking of wear see under point Control
Break of the steel laminae package	Break of the steel laminae package due to high shock energy / overload	Danger of ignition due to sparking	1) Put the unit out of operation 2) Disassemble the coupling and remove the rests of the steel laminae packages 3) Check coupling parts and exchange damaged coupling parts 4) Insert steel laminae packages, assemble coupling parts 5) Find out the reason of overload
	Operating parameters do not correspond to the performance of the coupling	Danger of ignition due to sparking	1) Put the unit out of operation 2) Check the operating parameters and select a larger coupling (consider installation space) 3) Assemble new coupling size 4) Check alignment

Schutzvermerk ISO 16016 beachten.	Gezeichnet: 26.03.09 Pz	Ersatz für: KTR-N vom 16.01.03
	Geprüft: 01.04.09 Pz	Ersetzt durch:



5 Enclosure A

Hints and instructions regarding the use in  hazardous areas

5.8 Breakdowns, Causes and Elimination

Breakdowns	Causes	Danger hints for hazardous areas	Elimination
Break of the steel laminae package	Mistake in service of the unit	Danger of ignition due to sparking	<ol style="list-style-type: none"> 1) Put the unit out of operation 2) Disassemble the coupling and remove the rests of the steel laminae packages 3) Check coupling parts and exchange damaged coupling parts 4) Insert steel laminae packages, assemble coupling parts 5) Instruct and train the service staff
Cracks in / break of the steel laminae packages / fixing screws	Drive vibrations	Danger of ignition due to sparking	<ol style="list-style-type: none"> 1) Put the unit out of operation 2) Disassemble the coupling and remove the rests of the steel laminae packages 3) Check coupling parts and exchange damaged coupling parts 4) Insert steel laminae packages, assemble coupling parts 5) Check alignment, correct if necessary 6) Find out the reason for the vibrations



If you operate with a worn laminae package (see item 5.2) and the subsequent contact of metal parts a due operation meeting the explosion protection requirements and acc. to Standard 94/9/EC is not ensured.



ATTENTION!

KTR does not assume any liabilities or guarantees regarding the use of spare parts and accessories which are not provided by KTR and for the damages resulting herefrom.

Schutzvermerk ISO 16016 beachten.	Gezeichnet: 26.03.09 Pz	Ersatz für: KTR-N vom 16.01.03
	Geprüft: 01.04.09 Pz	Ersetzt durch:



KTR Kupplungstechnik
GmbH
D-48407 Rheine

RADEX®-NC
Operating-/Assembly instructions

KTR-N 47210 EN
sheet: 18
edition: 5

5 Enclosure A

Hints and instructions regarding the use in  hazardous areas

5.9 EC Certificate of Conformity

EC Certificate of Conformity

corresponding to EC Standard 94/9/EC dated 23 March 1994
and to the legal regulations

The manufacturer - KTR Kupplungstechnik GmbH, D-48432 Rheine - states that the

RADEX®-NC Servo Laminae Couplings

described in these mounting instructions and explosion-proof designed correspond to Article 1 (3) b) of Standard 94/9/EC and comply with the general Safety and Health Requirements according to enclosure II of Standard 94/9/EC.

The couplings are certified according to Type Examination Certificate IBExU05ATEXB002 X.

According to article 8 (1) of Standard 94/9/EC the technical documentation is deposited with the:

IBExU
Institut für Sicherheitstechnik GmbH
Fuchsmühlenweg 7

09599 Freiberg

Rheine, 26.03.09
Date

i. V. 
Reinhard Wibbeling
Engineering Manager

i. V. 
Johannes Deister
Produktmanager

Schutzvermerk ISO 16016 beachten.	Gezeichnet: 26.03.09 Pz	Ersatz für: KTR-N vom 16.01.03
	Geprüft: 01.04.09 Pz	Ersetzt durch: