

REGOLATORE REGULATOR

Mod. AT-R



COD.ORDINE - ORDER CODE

mod.	filetto/thread
AT-R	1/8
AT-R	1/4
AT-R	3/8 - 1/2
AT-R	3/4
AT-R	1"

DIMENSIONI - SIZE

mod.AT-R	1/8 - 1/4	3/8 - 1/2	3/4 - 1"
A	64	78	129
B	42	60	80
C	42	60	80
D	32	46	66
E	42	60	80
F	30x1,5	38x2	55x2
G	21	30	40
L	1/8	1/8	1/4



DIAGRAMMA DI PORTATA CON PRESSIONE A 6 bar - FLOW RATE DIAGRAM AT 6 bar

1/8 - 1/4

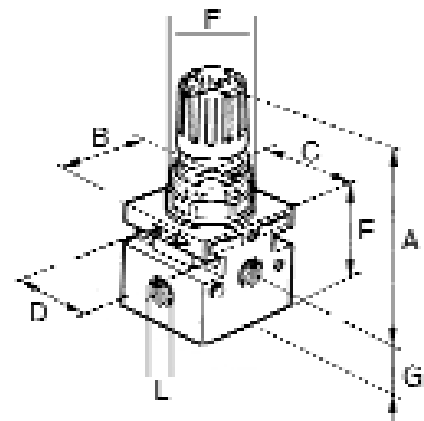
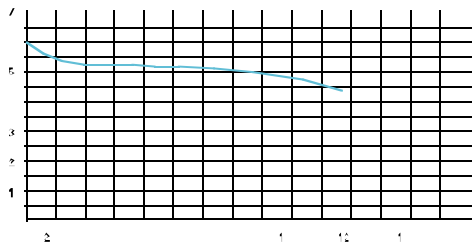

Portata NI/min. - Flow NI/min.

3/8 - 1/2

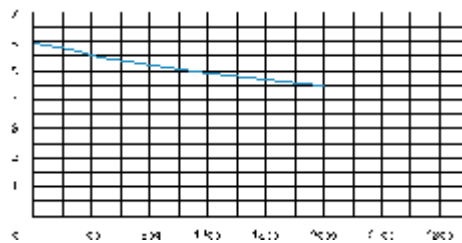

Portata NI/min. - Flow NI/min.

3/4 - 1"

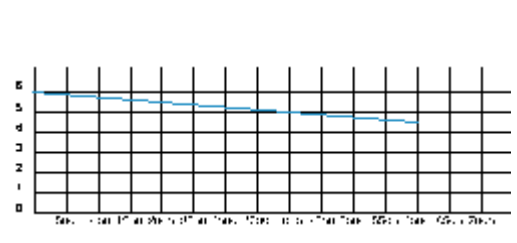

Portata NI/min. - Flow NI/min.

DATI TECNICI - SPECIFICATIONS

	1/8 - 1/4	3/8 - 1/2	3/4 - 1"
Attacco manometro - pressure gauge thread	1/8"	1/8"	1/4"
Peso - weight	0.3 kg	0.8 kg	2.2 kg
Viti di fissaggio a parete - wall clamp screw	M4x40	M4x50	M6x75
Campo di regolazione bar - pressure adjusting range (bar)	0-12	0-12	0-12
Pressione max di ingresso Maximum inlet pressure	bar 12 - psi 174 - kPa 1200 - MPa 1.2		
Portata a 6 bar - flow rate at 6 bar (87 psi - 600 kPa - 0,6 Mpa)	700 NI/min	2600 NI/min	4600 NI/min
Temperatura max a - maximum temperature at 10 bar, 145 psi, 1000 kPa, 1MPa °C	+50	+50	+50
Posizione di montaggio - mounting position	Qualsiasi - any position		