

# FILTRO REGOLATORE + LUBRIFICATORE FILTER REGULATOR + LUBRICATOR

Mod. AT-FR+L

Mod. AT-FR+L M

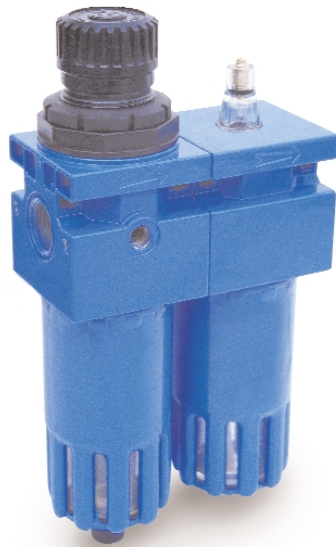
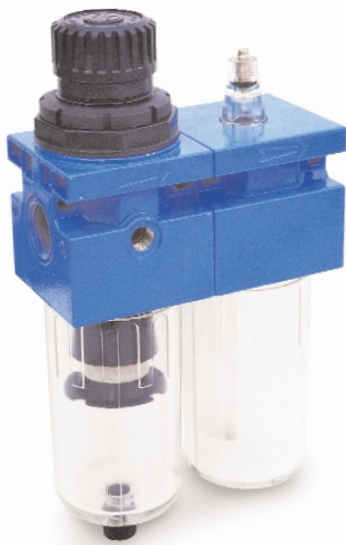

COD.ORDINE - ORDER CODE		PREZZO - PRICE
mod.	filetto/thread	
AT-FR+L	1/8	
AT-FR+L	1/4	
AT-FR+L	3/8 - 1/2	
AT-FR+LM	1/8	
AT-FR+LM	1/4	
AT-FR+LM	3/8 - 1/2	
AT-FR+LM	3/4	
AT-FR+LM	1"	

## DIMENSIONI - SIZE

mod.AT-FR+L / AT-FR+L M	1/8 - 1/4	3/8 - 1/2	3/4 - 1"
A metal	117	149	195
B transparent	112	143	-
C	64	78	129
D	42	60	80
E	76	109	146
F	42	60	80
G	84	120	160
L	1/8	1/8	1/4

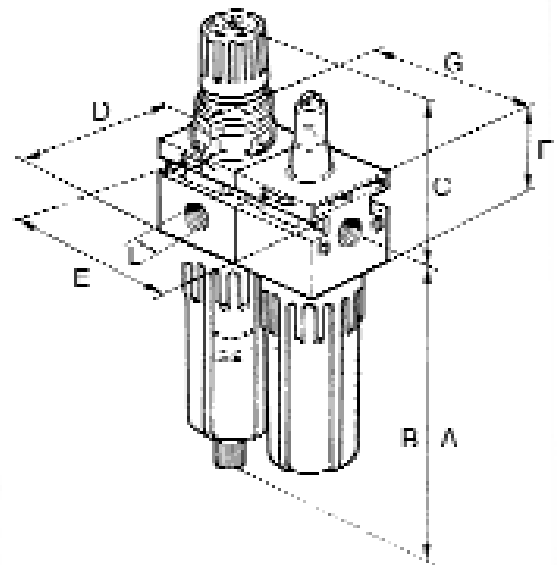

## DATI TECNICI - SPECIFICATIONS

	1/8 - 1/4	3/8 - 1/2	3/4 - 1"
Peso - weight	0.9 kg	2.0 kg	4.0 kg
Viti di fissaggio a parete - wall clamp screw	M4x40	M4x50	M6x75
Scarico condensa <i>Condensate drainage system</i>	di serie manuale / semiautomatico; a richiesta automatico (art. SA vedi accessori) <i>manual / semi-automatic; by request automatic (art. SA - see equipments)</i>		
Campo di regolazione bar - pressure adjusting range (bar)	0-12	0-12	0-12
Pressione max di ingresso(tazza metallo) <i>Maximum inlet pressure(metal cup)</i>	bar 18 - psi 261 - kPa 1800 - MPa 1.8		
Pressione max di ingresso(tazza trasparente) <i>Maximum inlet pressure(transparent cup)</i>	bar 12 - psi 174 - kPa 1200 - MPa 1.2		
Portata a 6 bar - flow rate at 6 bar (87 psi - 600 kPa - 0,6 MPa)	600 NI/min	2250 NI/min	4700 NI/min
Temperatura max a - maximum temperature at 10 bar, 145 psi, 1000 kPa, 1MPa °C	+50	+50	+50
Grado di filtrazione - degree of filtration	32 µm		
Fluido - fluid	aria compressa - compressed air		
Posizione di montaggio - mounting position	verticale - vertical		

Oli da utilizzare :sono consigliati per il corretto funzionamento dei lubrificatori: ISO E UNI FD22 ad esempio: Spinesso 22 (Esso), Tellus Oil 22 (Shell), Mobil DTE 22 (Mobil), Energol HLP 22 (BP). NB: non sono da utilizzare olii detergenti, olii per circuiti frenanti e solventi in generale. Oil recommended for correct operation: ISO and UNI FD22 for example: Spinesso 22 (Esso), Tellus Oil 22 (Shell), Mobil DTE 22 (Mobil), Energol HLP 22 (BP). Do not use detergent oils, brakings circuit oils and solvents in general. • A richiesta scarico condensa automatico (vedere accessori) mod. SA - By request automatic drainage system (see equipments) mod SA • A richiesta attacco 1/4 tazza per carico olio (vedere accessori) mod TA - By request cup with 1/4 inlet for oil feed (see equipments) mod TA.