

**032/..3** Dimensioni / Dimensions / Abmessungen / Encombremets / Dimensiones

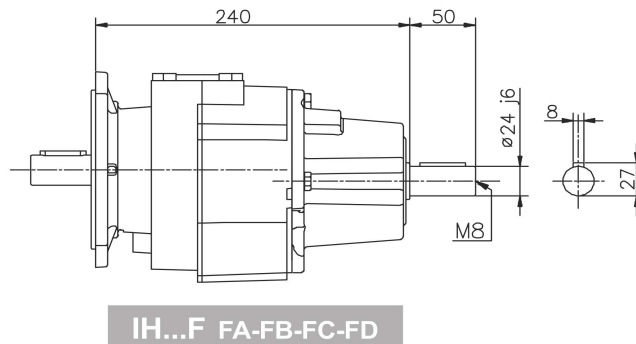

030	IH	PAM		Motore normale / Standard motor / Normaler Motor / Moteur normal / Motor normal			Motore autofrenante / Brake motor / Bremsmotor / Moteur frein / Motor-freno				
		~Kg	A	~Kg	X	Y	Z	~Kg	X	Y	Z
63	12.2	57	9.1	215	121	104	12.6	273	121	119	14.1
71		69	9.5	241	139	112	13.5	305	139	128	15.7
80		90	10.1	268	158	122	18.2	341	158	137	21.7
90s		90	10.1	296	173	130	22.1	373	173	130	27.6
90l		90	10.1	321	173	130	24.1	398	173	130	29.6
100		105	14.4	333	191	139	29.6	415	191	139	35.1
112		105	14.4	351	211	154	41.1	448	211	154	50.8

Per le dimensioni relative alla zona attacco motore (Pm, Dm, bm, tm) fare riferimento alla tabella di pag. 134.  
 For the dimensions concerning the motor connection area (Pm, Dm, bm, tm) please refer to the table shown at page 134.  
 Zu den Abmessungen des Motoranschlußflansches (Pm, Dm, bm, tm) siehe Tabelle auf Seite 134.  
 Pour les dimensions concernant la zone de montage du moteur (Pm, Dm, bm, tm) lire SVP le tableau à la page 134.  
 Para las magnitudes correspondientes a la zona del motor (Pm, Dm, bm, tm) consulte la tabla de la página 134.

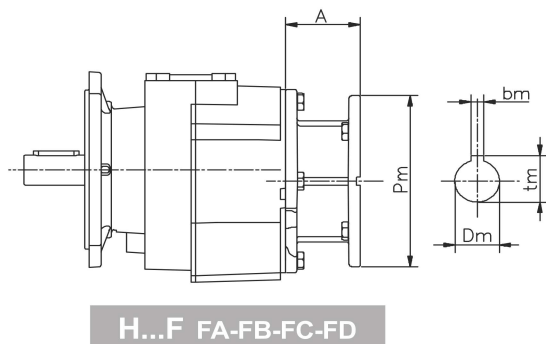
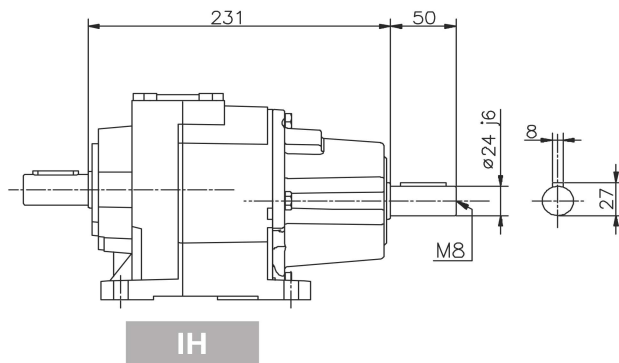
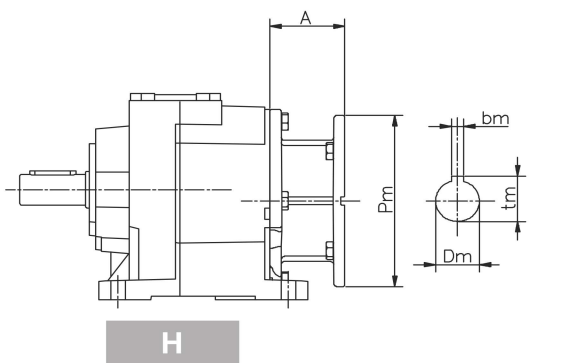
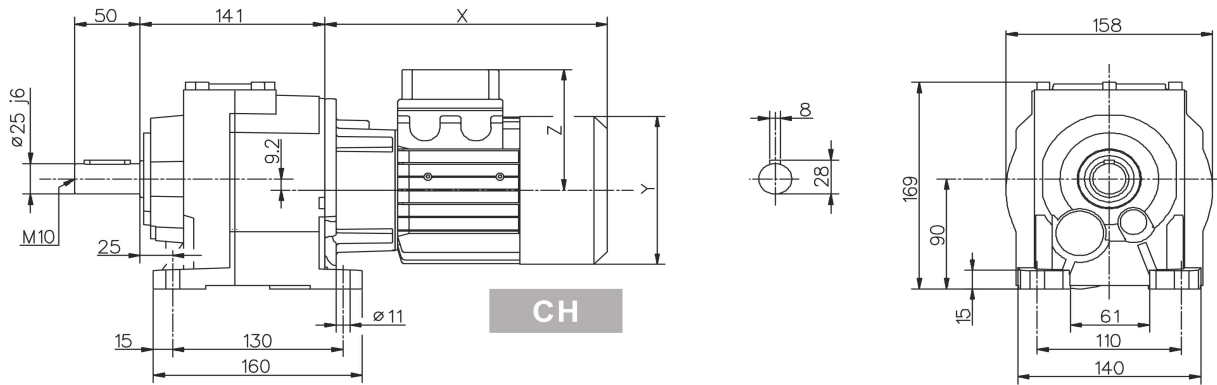