

042/.3 Dimensioni / Dimensions / Abmessungen / Encombremets / Dimensiones

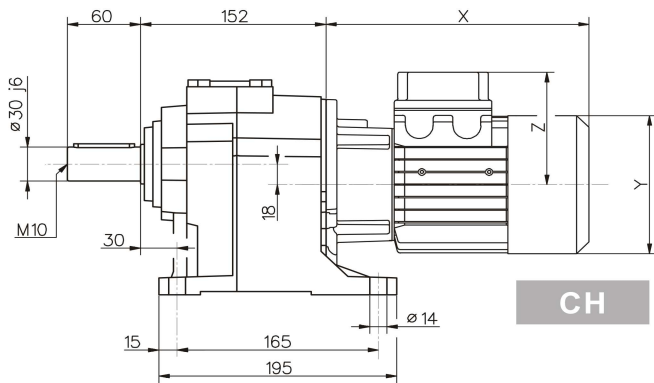

CH

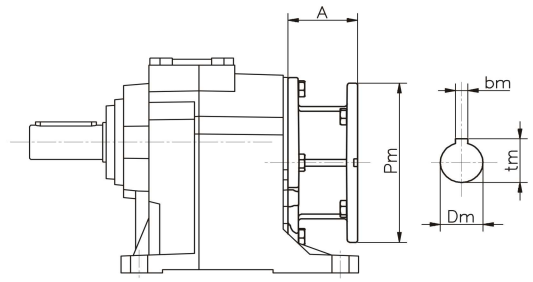
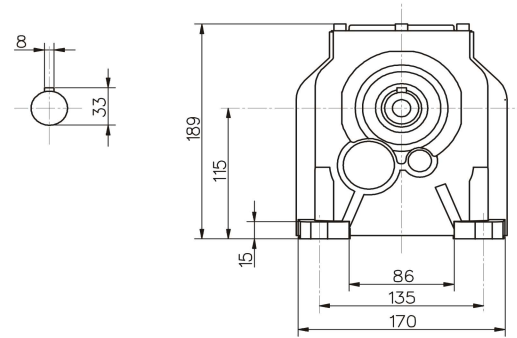

H

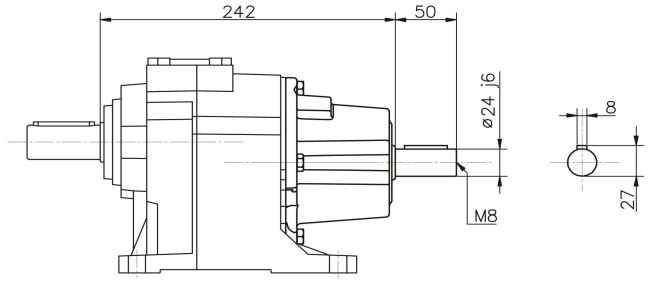

IH

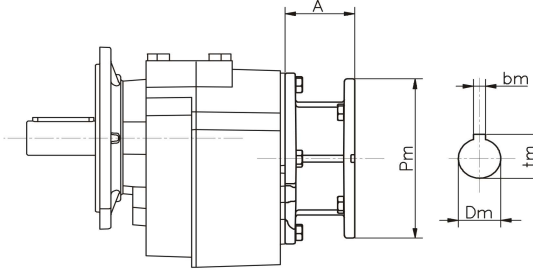

H...F FA-FB-FC-FD

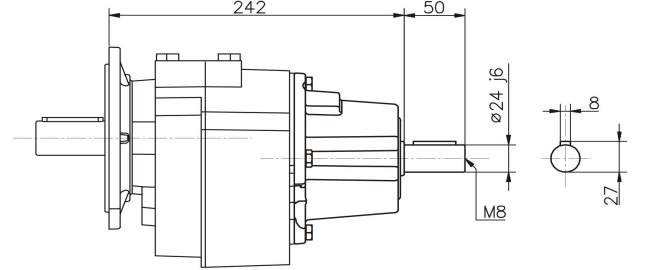

IH...F FA-FB-FC-FD

040	IH	PAM		Motore normale / Standard motor / Normaler Motor / Moteur normal / Motor normal			Motore autofrenante / Brake motor / Bremsmotor / Moteur frein / Motor-freno				
		~Kg	A	~Kg	X	Y	Z	~Kg	X	Y	Z
63	15.1	57	12	215	121	104	15.5	273	121	119	17
71		69	12.4	241	139	112	16.4	305	139	128	18.6
80		90	13	268	158	122	21.1	341	158	137	24.6
90s		90	13	296	173	130	25	373	173	130	30.5
90l		90	13	321	173	130	27	398	173	130	32.5
100		105	17.3	333	191	139	32.5	415	191	139	38
112		105	17.3	351	211	154	44	448	211	154	53.7

Per le dimensioni relative alla zona attacco motore (Pm, Dm, bm, tm) fare riferimento alla tabella di pag. 134.
 For the dimensions concerning the motor connection area (Pm, Dm, bm, tm) please refer to the table shown at page 134.
 Zu den Abmessungen des Motoranschlußflansches (Pm, Dm, bm, tm) siehe Tabelle auf Seite 134.
 Pour les dimensions concernant la zone de montage du moteur (Pm, Dm, bm, tm) lire SVP le tableau à la page 134.
 Para las magnitudes correspondientes a la zona del motor (Pm, Dm, bm, tm) consulte la tabla de la página 134.

