

**062/..3** Dimensioni / Dimensions / Abmessungen / Encombremets / Dimensiones

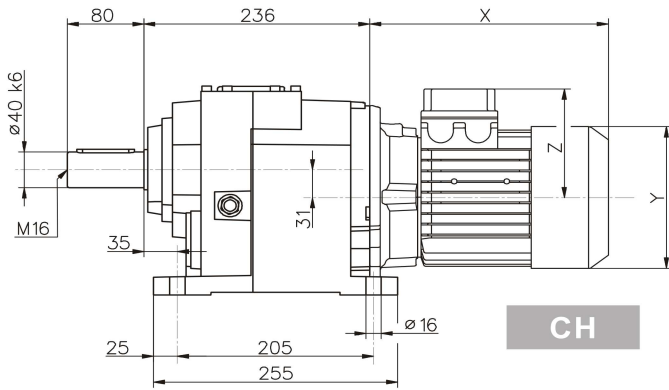

**CH**

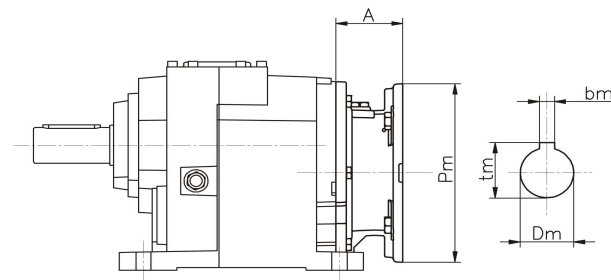

**H**

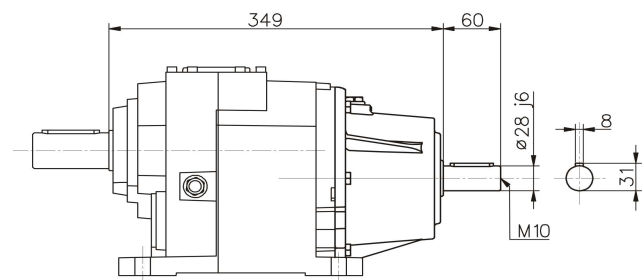

**IH**

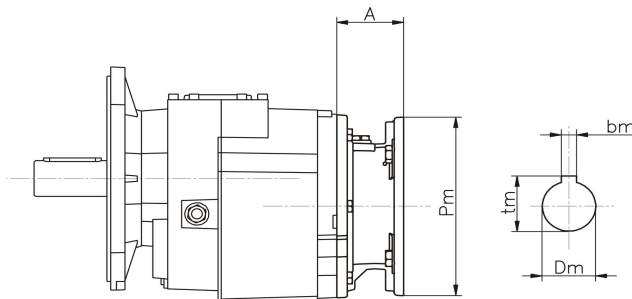

**H...F FA-FB-FC**

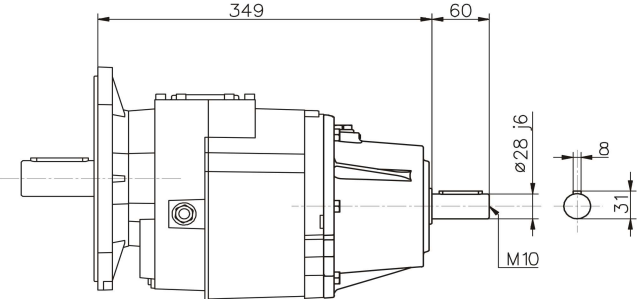

**IH...F FA-FB-FC**

060	IH	PAM		Motore normale / Standard motor / Normaler Motor / Moteur normal / Motor normal				Motore autofrenante / Brake motor / Bremsmotor / Moteur frein / Motor-freno			
	~Kg	A	~Kg	X	Y	Z	~Kg	X	Y	Z	~Kg
71	35,2	49	29,1	221	139	112	32,7	285	139	128	34,9
80		70	31,2	248	158	122	37,8	321	158	137	41,3
90s		70	31,2	276	173	130	40,2	353	173	130	45,7
90l		70	31,2	301	173	130	41,7	378	173	130	47,2
100		85	33,3	335	191	139	46,8	417	191	139	52,3
112		85	33,3	356	211	154	58,2	453	211	154	67,9
132s		110	36	396	249	194	72,2	495	249	194	82,5
132m		110	36	443	249	194	83,8	547	249	194	98,5

Per le dimensioni relative alla zona attacco motore (Pm, Dm, bm, tm) fare riferimento alla tabella di pag. 134.  
 For the dimensions concerning the motor connection area (Pm, Dm, bm, tm) please refer to the table shown at page 134.  
 Zu den Abmessungen des Motoranschlußflansches (Pm, Dm, bm, tm) siehe Tabelle auf Seite 134.  
 Pour les dimensions concernant la zone de montage du moteur (Pm, Dm, bm, tm) lire SVP le tableau à la page 134.  
 Para las magnitudes correspondientes a la zona del motor (Pm, Dm, bm, tm) consulte la tabla de la página 134.

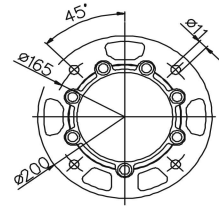
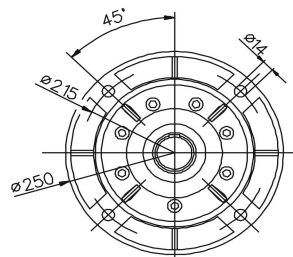
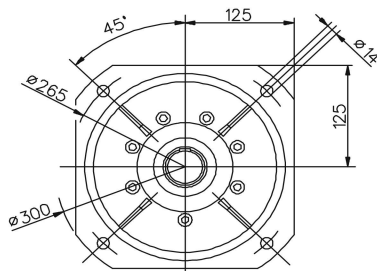
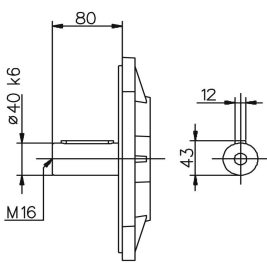
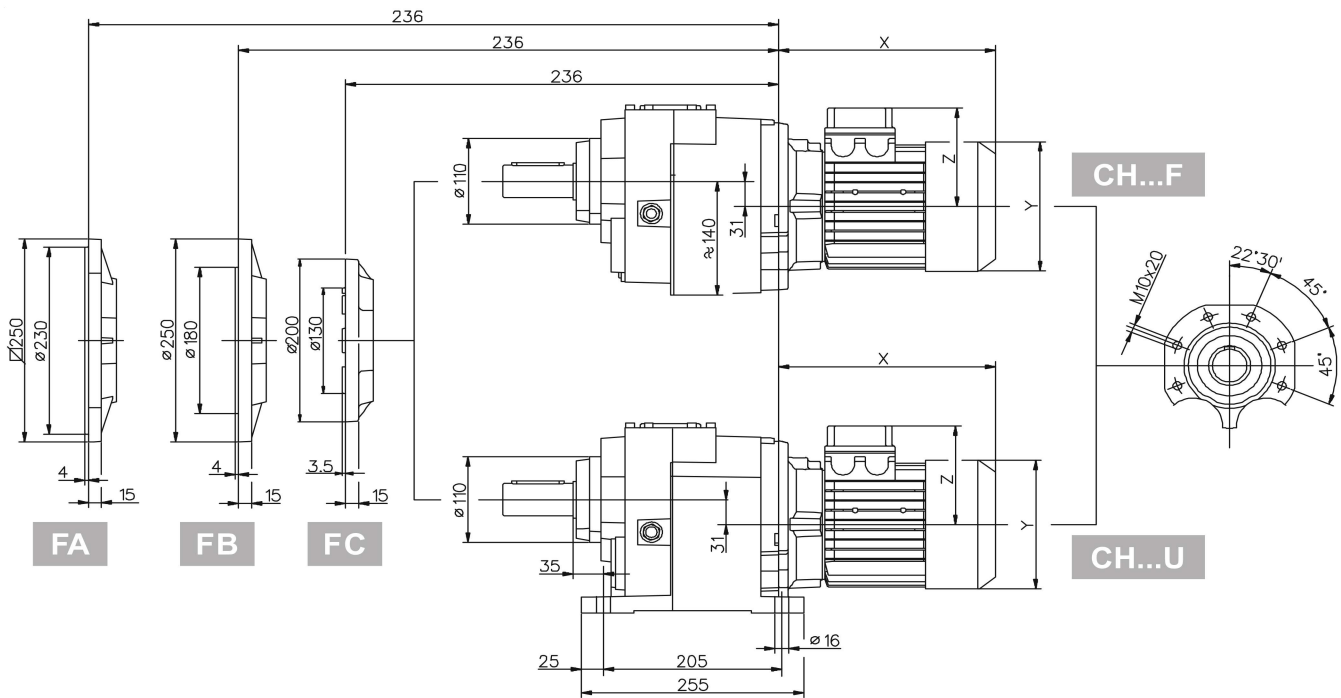
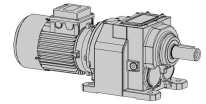

FA

FB

FC

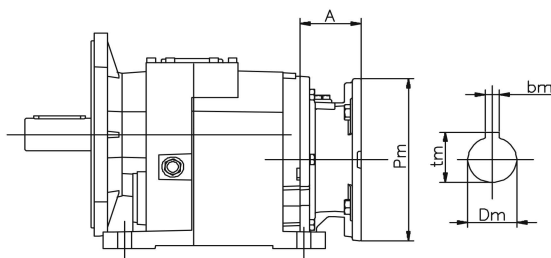

H...U FA-FB-FC

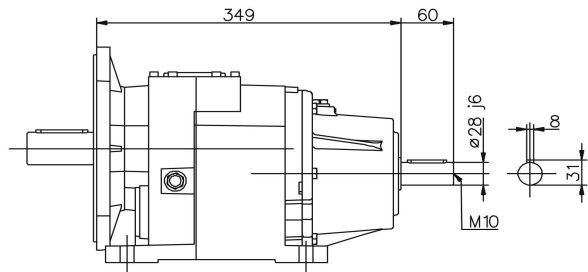

IH...U FA-FB-FC