

082/.3 Dimensioni / Dimensions / Abmessungen / Encombremets / Dimensiones

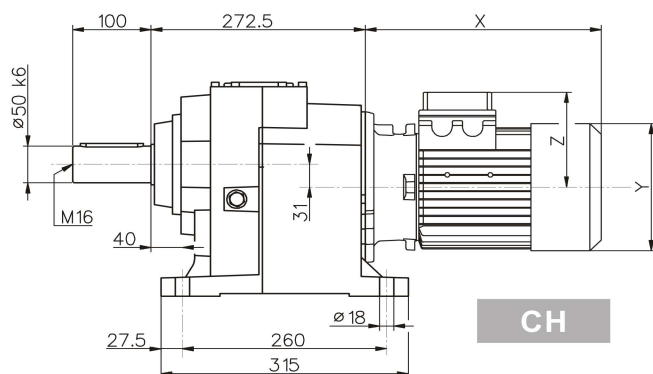

CH

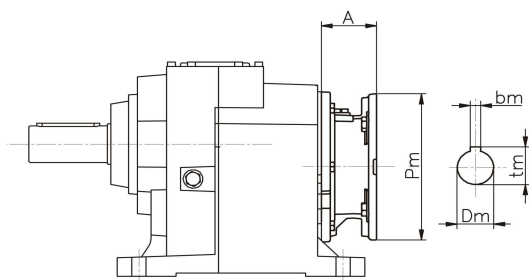

H

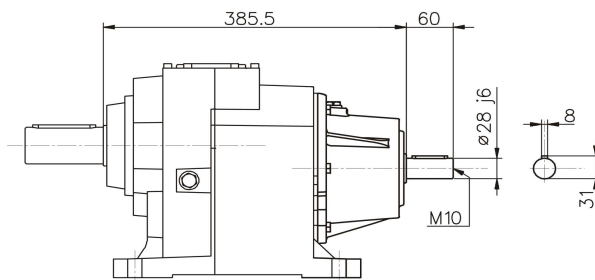

IH

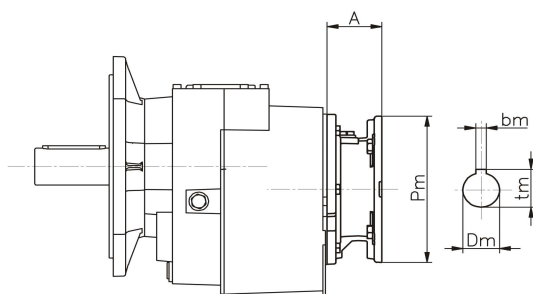

H...F FA-FB-FC

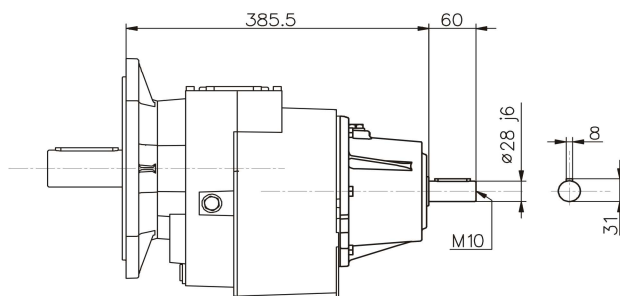

IH...F FA-FB-FC

080	IH	PAM		Motore normale / Standard motor / Normaler Motor / Moteur normal / Motor normal			Motore autofrenante / Brake motor / Bremsmotor Moteur frein / Motor-freno				
	~Kg	A	~Kg	X	Y	Z	~Kg	X	Y	Z	~Kg
80		70	53,1	248	158	122	59,7	321	158	137	63,2
90s		70	53,1	276	173	130	62,1	353	173	130	67,6
90l		70	53,1	301	173	130	63,6	378	173	130	69,1
100		85	55,2	335	191	139	68,7	417	191	139	74,2
112	57,1	85	55,2	356	211	154	80,1	453	211	154	89,8
132s		110	57,2	396	249	194	94,1	495	249	194	104,4
132m		110	57,2	443	249	194	105,7	547	249	194	120,4
160s		158	64,5	522	310	244	-	-	-	-	-
160l		158	64,5	566	310	244	-	-	-	-	-

Per le dimensioni relative alla zona attacco motore (Pm, Dm, bm, tm) fare riferimento alla tabella di pag. 134.
 For the dimensions concerning the motor connection area (Pm, Dm, bm, tm) please refer to the table shown at page 134.
 Zu den Abmessungen des Motoranschlußflansches (Pm, Dm, bm, tm) siehe Tabelle auf Seite 134.
 Pour les dimensions concernant la zone de montage du moteur (Pm, Dm, bm, tm) lire SVP le tableau à la page 134.
 Para las magnitudes correspondientes a la zona del motor (Pm, Dm, bm, tm) consulte la tabla de la página 134.

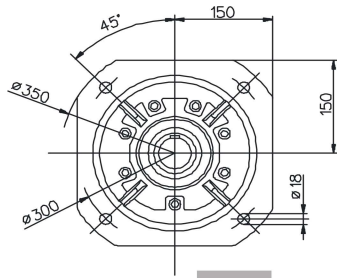
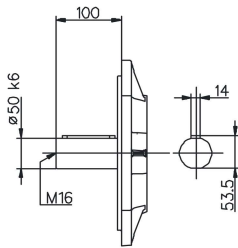
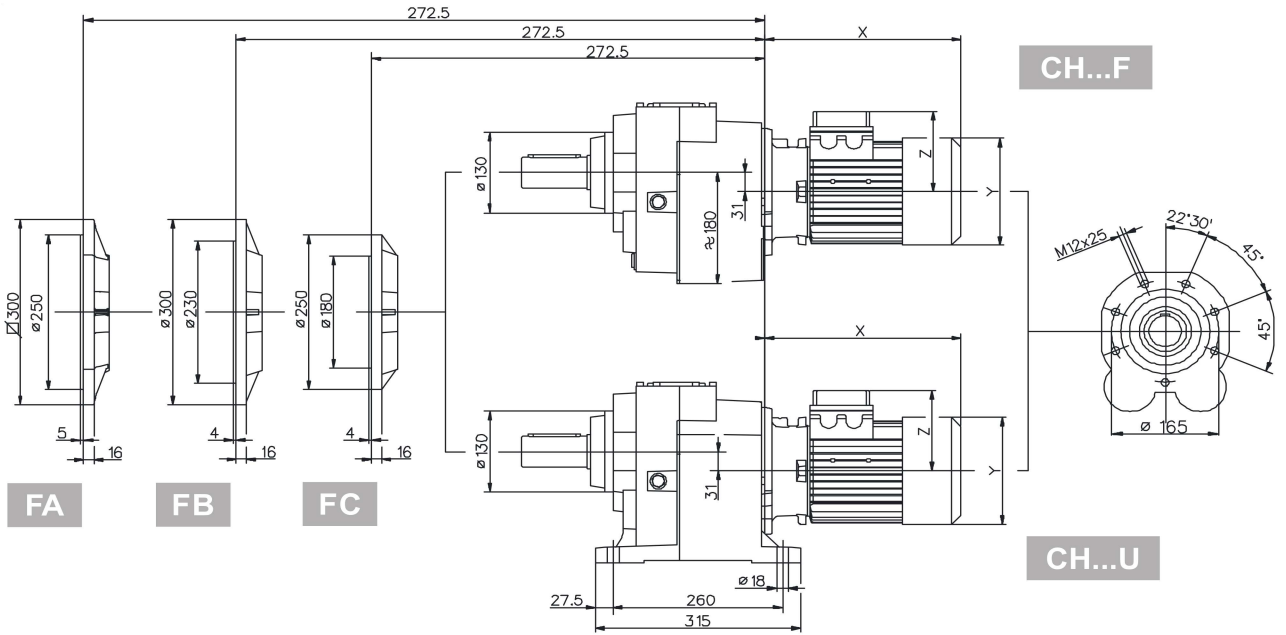
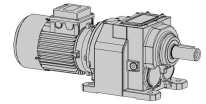

FA

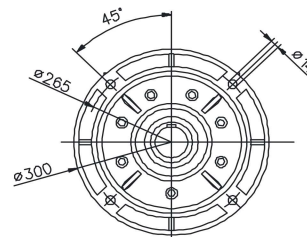

FB

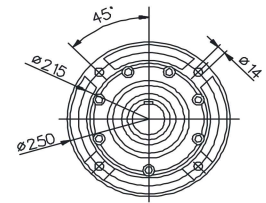

FC

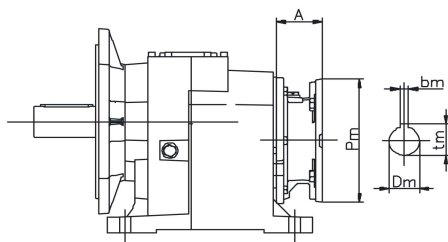

H...U FA-FB-FC

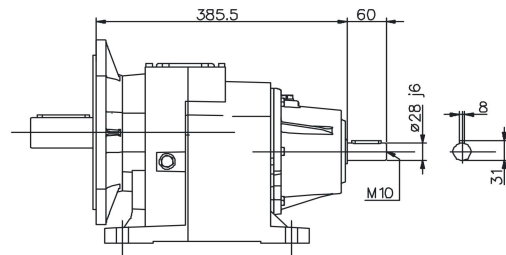

IH...U FA-FB-FC