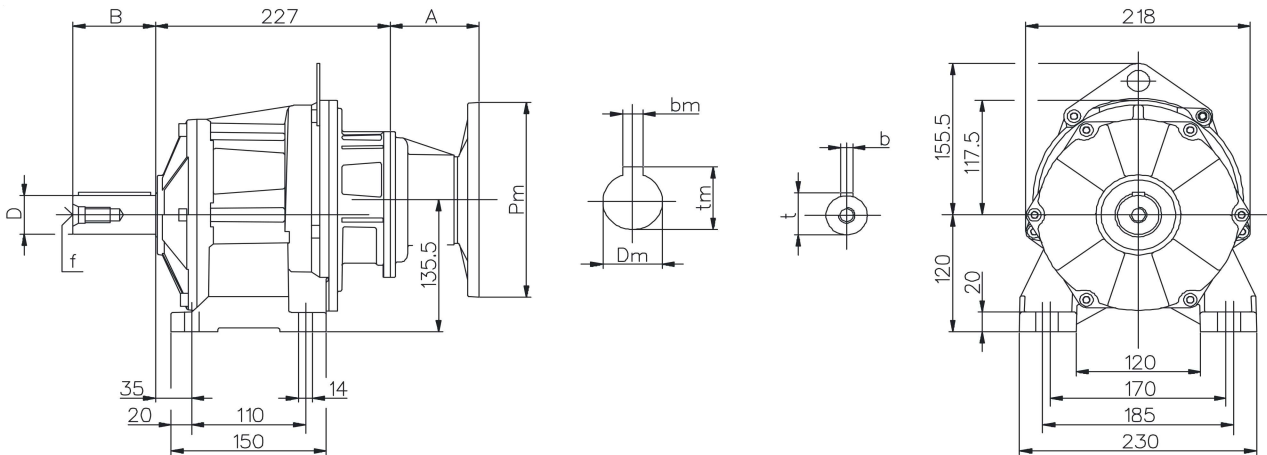
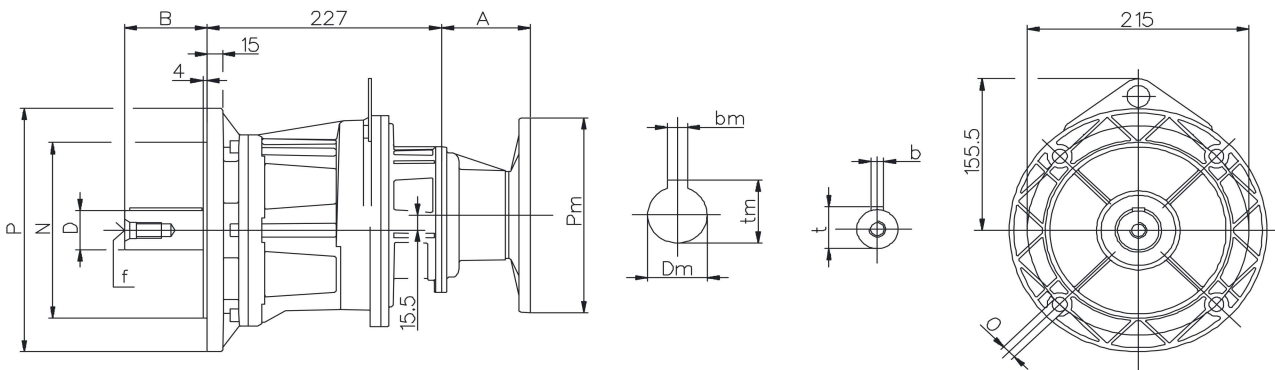

**H**

**H...F**

Alberi / Shaft / Wellen / Arbres / Ejes				
D j6	B	b	t	f
40	80	12	43	M16
(28)	(60)	(8)	(31)	(M10)

Flange / Flanges / Flansche / Flasques / Bridas			
P	M	N f8	O
250	215	180	14
(200)	(165)	(130)	(14)

PAM	A	kg
063	55	14.6
071	55	14.7
080 - 090	86	15.3

- Peso senza motore (..) Solo su richiesta
- Weight without motor (..) Only on request
- Gewicht ohne Motor (..) Auf Wunsch
- Poids sans moteur (..) Seulement sur demande
- Peso sin motor (..) Sólo bajo pedido

Per le dimensioni relative alla zona attacco motore (Pm, Dm, bm, tm) fare riferimento alla tabella di pag. 134.  
 For the dimensions concerning the motor connection area (Pm, Dm, bm, tm) please refer to the table shown at page 134.  
 Zu den Abmessungen des Motoranschlußflansches (Pm, Dm, bm, tm) siehe Tabelle auf Seite 134.  
 Pour les dimensions concernant la zone de montage du moteur (Pm, Dm, bm, tm) lire SVP le tableau à la page 134.  
 Para las magnitudes correspondientes a la zona del motor (Pm, Dm, bm, tm) consulte la tabla de la página 134.