

062/.3 Dimensioni / Dimensions / Abmessungen / Encombremets / Dimensiones

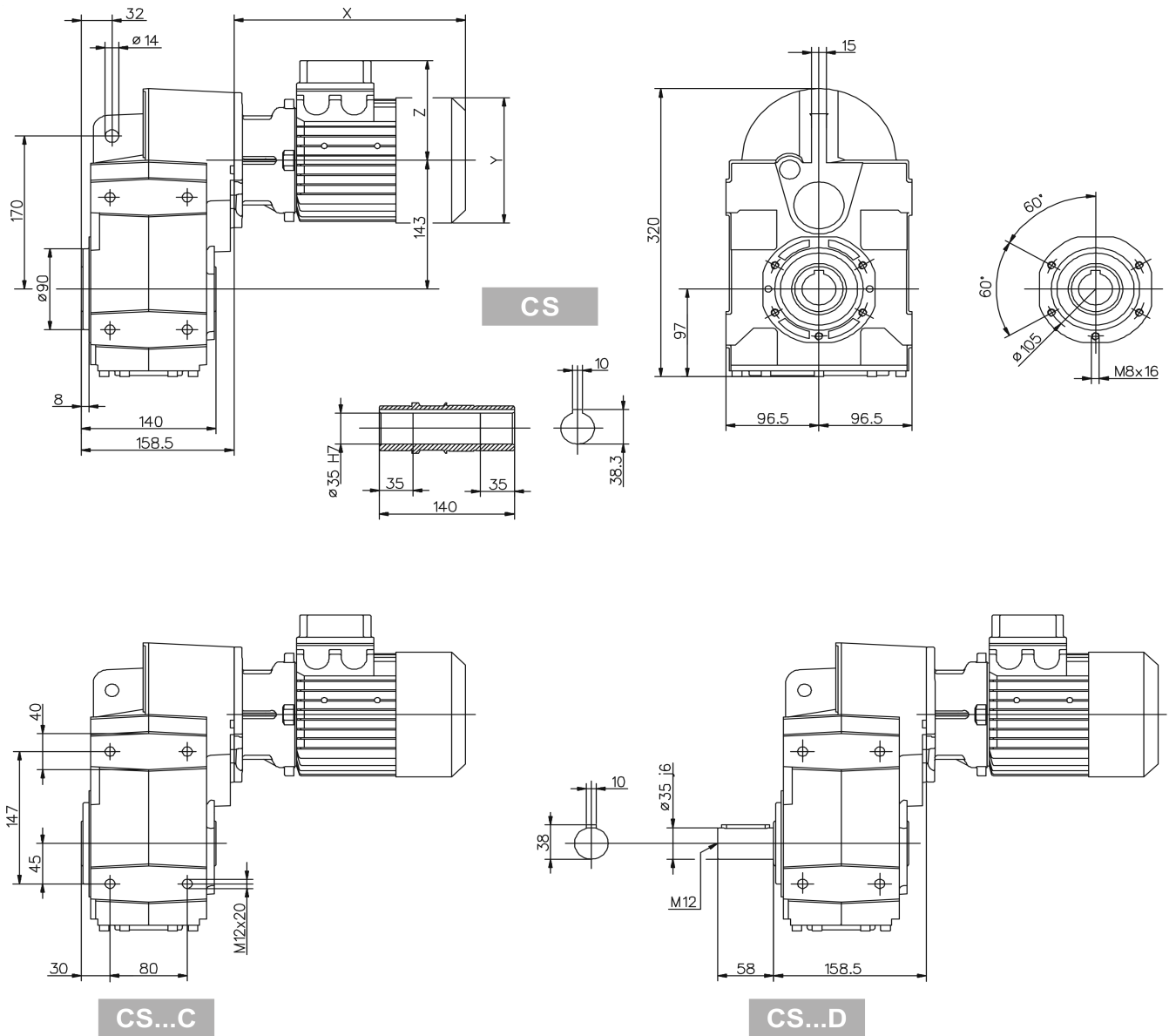

060	IS	PAM		Motore normale / Standard motor / Normaler Motor / Moteur normal / Motor normal				Motore autofrenante / Brake motor / Bremsmotor / Moteur frein / Motor-freno			
	~Kg	A	~Kg	X	Y	Z	~Kg	X	Y	Z	~Kg
71	24.8	69	22	241	139	112	26	305	139	128	28.3
80		90	22.7	268	158	122	30.8	341	158	137	34.3
90s		90	22.7	296	173	130	34.7	373	173	130	40.2
90l		90	22.7	321	173	130	36.7	398	173	130	42.2
100		105	27	333	191	139	42.2	415	191	139	47.7
112		105	27	351	211	154	53.7	448	211	154	63.4

Per le dimensioni relative alla zona attacco motore (Pm, Dm, bm, tm) fare riferimento alla tabella di pag. 223.
 For the dimensions concerning the motor connection area (Pm, Dm, bm, tm) please refer to the table shown at page 223.
 Zu den Abmessungen des Motoranschlußflansches (Pm, Dm, bm, tm) siehe Tabelle auf Seite 223.
 Pour les dimensions concernant la zone de montage du moteur (Pm, Dm, bm, tm) lire SVP le tableau à la page 223.
 Para las magnitudes correspondientes a la zona del motor (Pm, Dm, bm, tm) consulte la tabla de la página 223.

