

Intelligent Drivesystems, Worldwide Services



EN

**G1014**

IE1  
Standard

IE2

IE3

**NORDBLOC.1 2-stage helical-bevel gear unit**

SK 920072.1 – SK 92772.1

SK 930072.1 – SK 93772.1

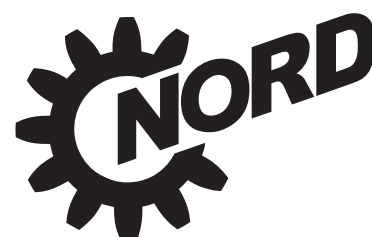

**DRIVESYSTEMS**

# Contens

INTRODUCTION .....	A 1 - 3
STANDARDS, REGULATIONS, NOMENCLATURE .....	A 4 - 8
OIL FILL VOLUMES .....	A 9
PAINTING .....	A10
POWER AND SPEED TABLES .....	B 2 - 11
POWER AND SPEED RATIO TABLES W and IEC ADAPTERS .....	B12 - 17
DIMENSIONED DRAWINGS .....	B18 - 50

SK 920072.1 - SK 92772.1



SK 930072.1 - SK 93772.1

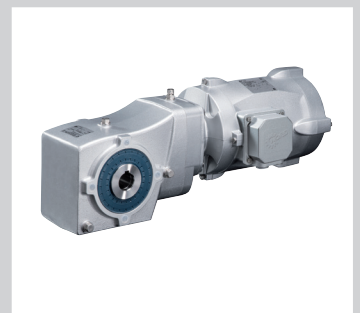



## Headquarters and Technology Centre

- in Bargteheide, close to Hamburg

### Mechanical products

Gear units

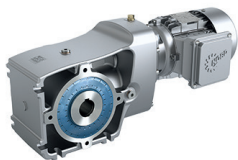

### Electrical products

Motors



### Electronic products

Inverters, motor starters and distribution systems

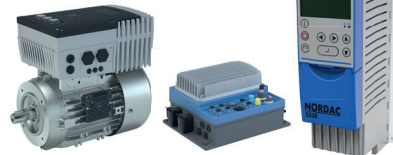

## Innovative drive solutions

- for more than 100 branches of industrial



Gear unit production



Motor production



Inverter production

## 7 state-of-the-art production plants

- produce gear units, motors and inverters also for complete drive solutions from a single source



The above map image is for information purpose and may not have been prepared or be suitable for legal purpose and we do not own any responsibility for correctness or authenticity of the same.

## Subsidiaries and sales partners in 89 countries on 5 continents

- provide local stocks
- assembly and production centres
- technical support
- customer service



## More than 3,300 employees throughout the world

- create customer oriented solutions

# 2-stage bevel helical gear unit

Series **SK 920072.1 - SK 92772.1**  
**SK 930072.1 - SK 93772.1**



## Introduction

The 2-stage bevel helical gear unit series is available in 5 sizes and two series.

- SK920072.1      SK930072.1
- SK92072.1      SK93072.1
- SK92172.1      SK93172.1
- SK92372.1      SK93372.1
- SK92672.1      SK93672.1
- SK92772.1      SK93772.1

Two series are available in all sizes.

- **SK920072.1 - SK92772.1**  
Serie - die cast housing series as universal housing with B14 flange and B5 foot mounting facility
- **SK930072.1 - SK93772.1**  
Serie - cast housing series with smooth, closed surfaces, B14 flange

This results in the 4 basic versions of the gear unit (see pictures).

- **SK920072.1 - SK92772.1 A**  
Die cast housing, B14 flange attachment, hollow shaft version, B5 foot-mounted version
- **SK930072.1 - SK93772.1 A**  
Cast housing, B14 flange attachment, hollow shaft version
- **SK920072.1 - SK92772.1 V**  
Die cast housing, B14 flange attachment, solid shaft version, B5 foot-mounted version
- **SK930072.1 - SK93772.1 V**  
Cast housing, B14 flange attachment, solid shaft version

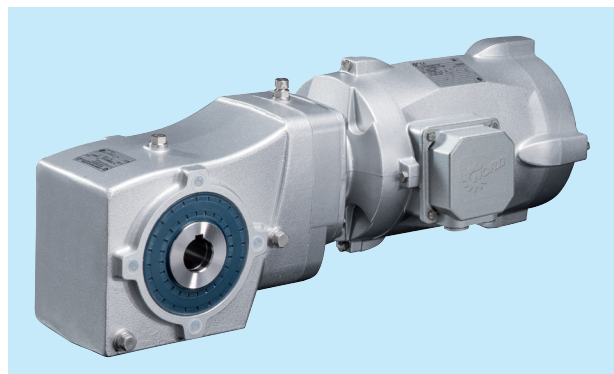
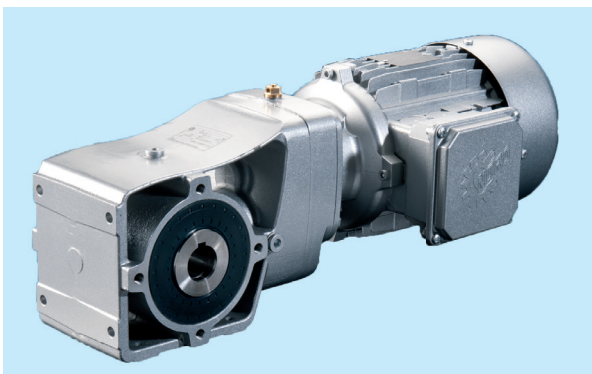



# 2-stage bevel helical gear unit

Series **SK 920072.1 - SK 92772.1**  
**SK 930072.1 - SK 93772.1**

## Basic versions

SK920072.1 - SK92772.1 A



SK930072.1 - SK93772.1 A

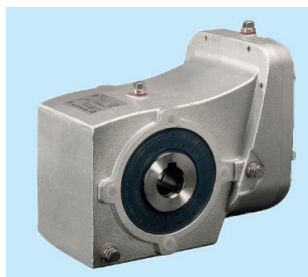

SK920072.1 - SK92772.1 V

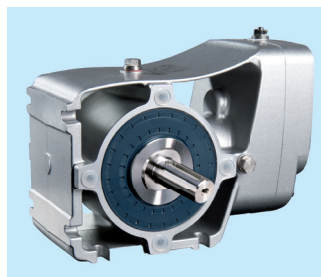

SK930072.1 - SK93772.1 V

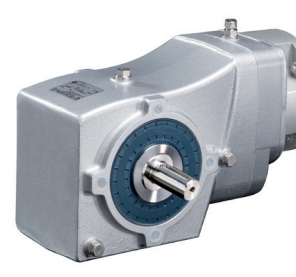

With the SK930072.1 - SK93772.1 version it is possible to machine the horizontal and vertical surfaces of the housing in order to achieve the axis heights of the SK920072.1 - SK92772.1 series. It is also possible to position threaded holes in the same location as the foot mounting holes of the SK920072.1 - SK92772.1 series, so that this housing can be optionally converted to a foot mounted housing with **B14 attachment**. **On request, this version can also be implemented by reworking.**

### All sizes and series can be supplied with the following option configurations:

- D Torque support
- F B5 Output flange
- ASH Shrink disc version with cover
- B Fixing element
- H Cover (for hollow shaft version)
- L Solid shaft on both sides

### On the drive side, the following versions are available:

- Direct motor attachment
- IEC adapter
- NEMA Adapter
- W cylinder

**For all versions the die cast or cast housing can be optionally treated with nsd tpuH.**

## Structure of power and speed tables - Type Gear unit motor

### 0,55 kW → Gear unit motor power

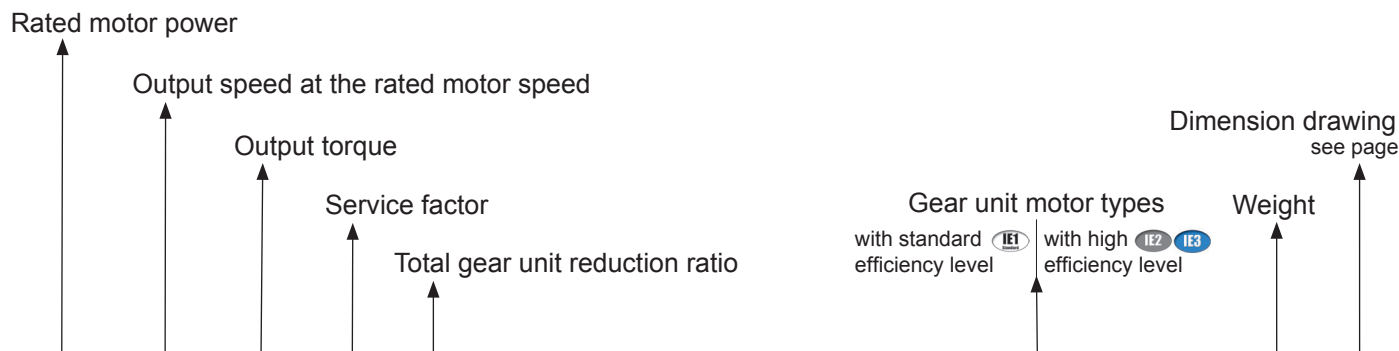

P <sub>1</sub> [kW]	n <sub>2</sub> [min <sup>-1</sup> ]	M <sub>2</sub> [Nm]	f <sub>B</sub>	i <sub>ges</sub>	F <sub>R</sub> [kN]	F <sub>A</sub> [kN]	F <sub>R VL</sub> [kN]	F <sub>A VL</sub> [kN]	Gear unit motor			IE1	mm
									IE1	IE2	IE3	kg	
0,55	21	248	2,0	66,96	10,2	25,0	-	-	SK 92772.1 - 80 S/4	SK 92772.1 - 80 SH/4		43,8	B30-31
	24	221	2,0	59,68	10,2	25,0	-	-					
	27	195	3,0	52,64	10,3	25,0	-	-					
	30	174	3,0	46,92	10,3	25,0	-	-					
	33	161	3,9	43,44	10,3	25,0	-	-	SK 93772.1 - 80 S/4	SK 93772.1 - 80 SH/4			B42-43
0,75	21	339	1,4	66,96	10,0	25,0	-	-	SK 92772.1 - 80 L/4	SK 92772.1 - 80 LH/4	SK 92772.1 - 80 LP/4	45,0	B30-31
	24	302	1,4	59,68	10,1	25,0	-	-					
	27	266	2,2	52,64	10,1	25,0	-	-					
	30	237	2,2	46,92	10,2	25,0	-	-					
	⋮								SK 93772.1 - 80 L/4	SK 93772.1 - 80 LH/4	SK 93772.1 - 80 LP/4		B42-43

Permitted overhung force, output end

#### Normal bearing

the listed values for  $F_R$  are calculated with  $F_A = 0$

According to the ecological design directive, known as EU Directive 2009/125/EU Ordinance No. 640/2009, at present only motors of at least efficiency class IE2 may be sold in the European Union for certain applications in the power range from 0.75 kW to 375 kW.

NORD already supplies motors with efficiency class IE2 from a power of 0.55 kW, even though this is only mandatory above a power of 0.75 kW. In addition, NORD already supplies highly efficient IE3 motors, which will only become mandatory from 2015 or 2017.

However, depending on the application, the previously used lower efficiency motors, e.g. with efficiency class IE1 may also be used.

The exempted applications are listed on page ⇒ A5 of the NORD motor catalogue M7000.

The power and speed ratio tables for gear units and geared motors apply for both geared motor types with the high efficiency levels IE2 and IE3 as well as for geared motor types with standard efficiency (IE1).

Permitted axial force, output end

#### Normal bearing

the listed values for  $F_A$  are calculated with  $F_R = 0$

The output speeds  $n_2$ , output torques  $M_2$  and operating factors  $f_B$  are based on motor powers of 0.55 kW and above for NORD motors with efficiency level IE2, and rated motor powers less than 0.55 kW are based on the nominal speeds of NORD motors with efficiency class IE1.

Regardless of the efficiency class which is actually selected, the output speeds  $n_2$ , output torques  $M_2$  and operating factors  $f_B$  as listed in the power and speed tables always give sufficiently accurate results, as the deviation in speed due to the efficiency class is at the most 3% for IE1 and IE3.

Usually, other influences, e.g. the torque required by the application (idling, partial load, full load) have a greater effect on the precise speed.

**Please contact us in case you have very high requirements for precise speed.**

The NORD motor catalogue M7000 lists the motor data for the various efficiency classes IE1, IE2, IE3.

## Structure of the Performance Tables: Type W and type IEC

SK 92772.1 - IEC → Gear unit type  
SK 92772.1 - W

Operating factors  $f_B$  with the IEC version are identical to the those of the same motor output with direct motor mounting. The  $f_B$  values are listed on the pages specified.

IEC motor sizes and IEC standard outputs as per DIN EN 50347

	$i_{ges}$	$n_2$ $n_1 = 1400 \text{min}^{-1}$ [ $\text{min}^{-1}$ ]	$M_{2max}$ $f_B = 1$ [Nm]	W			IEC								
				$P_{1max}$		$f_B \geq 1$	$f_B \Rightarrow$ B2-11								
				$n_1 = 1400 \text{min}^{-1}$ [kW]	$n_1 = 930 \text{min}^{-1}$ [kW]	$n_1 = 700 \text{min}^{-1}$ [kW]	63	71	80	90	100	112	132		
SK 92772.1	66,96 59,68 52,64	21 23 27	489 436 578	1,07 1,07 1,61	0,71 0,71 1,07	0,54 0,54 0,80				*					
⋮															
	5,12 4,17	273 336	505 496	9,20 9,20	6,11 6,11	4,60 4,60									

**Legend:**

- italic indicates:* Max. drive power  $P_{1max}$  (Typ W)
- non italic indicates:** with  $P_{1max}$  the operating factor  $f_B = 1$
- italic indicates:* with  $P_{1max}$  the operating factor  $f_B > 1$
- Asterisk indicates: Caution** do not exceed the max. driver power  $P_{1max}$  (Type W column)
- Shaded field indicates:** IEC adapter is available for this IEC motor size and this reduction ratio

## Tolerances

Category	Information								
Output and input shafts	<p>Tolerance of the hole (DIN 478) :</p> <p>Ø 14 - Ø 40 mm = ISO h6</p> <p>Threaded holes :</p> <p>= Ø 14 - Ø 16 mm → M5            &gt; Ø 16 - Ø 21 mm → M6            &gt; Ø 21 - Ø 24 mm → M8            &gt; Ø 24 - Ø 30 mm → M10            &gt; Ø 30 - Ø 38 mm → M12            &gt; Ø 38 - Ø 50 mm → M16</p>								
Hollow shaft	Tolerance of hollow shaft - Ø 14 (DIN 748) as per ISO H7								
Keys	Keys acc. DIN 6885, page 1								
Shaft height	Shaft height «h» as per DIN 747								
Flanges	<p>Tolerance of the hole - Ø as per DIN EN 50347</p> <p>Tolerance of the flange centring - Ø as per ISO j6</p>								
IEC adapters	<p>Tolerance of the hole - Ø as per DIN EN 50347</p> <p>Tolerance of the flange centring as per ISO H7</p>								
Motors	<p>Dimensions of motors are subject to change.</p> <p> <table style="display: inline-table; vertical-align: middle;"> <tr> <td style="padding-right: 5px;">g1Bre</td> <td rowspan="6" style="font-size: 3em; vertical-align: middle;">}</td> <td rowspan="6" style="padding-left: 10px;">Brake motor dimensions</td> </tr> <tr><td>kBre</td></tr> <tr><td>oBre</td></tr> <tr><td>mBre</td></tr> <tr><td>nBre</td></tr> <tr><td>pBre</td></tr> </table> </p>	g1Bre	}	Brake motor dimensions	kBre	oBre	mBre	nBre	pBre
g1Bre	}	Brake motor dimensions							
kBre									
oBre									
mBre									
nBre									
pBre									
Housings	The housings are made of cast materials. Thus, due to the manufacturing process, the dimensions of the un-machined housing surfaces may differ slightly from the nominal dimensions.								
Thread	Fastening threads in cast components for use by customers (housing / IEC attachment adapter) are produced as standard threads according to DIN 13-1.								



## Installation positions - nomenclature

For gear units and geared motors, NORD specifies six installation positions from M1 to M6 as shown in the following diagrams. The relevant installation position must be stated when ordering.

Changes to the installation position require adjustment of the quantity of oil, and often other measures such as the installation of encapsulated roller bearings. Damage may result if the necessary measures are not observed. Tilted installation positions between the 6 basic positions are possible. Please contact us.

The versions, with the position of the oil level plug, the vent plug and the oil drain plug can be found on ⇒  **A8**

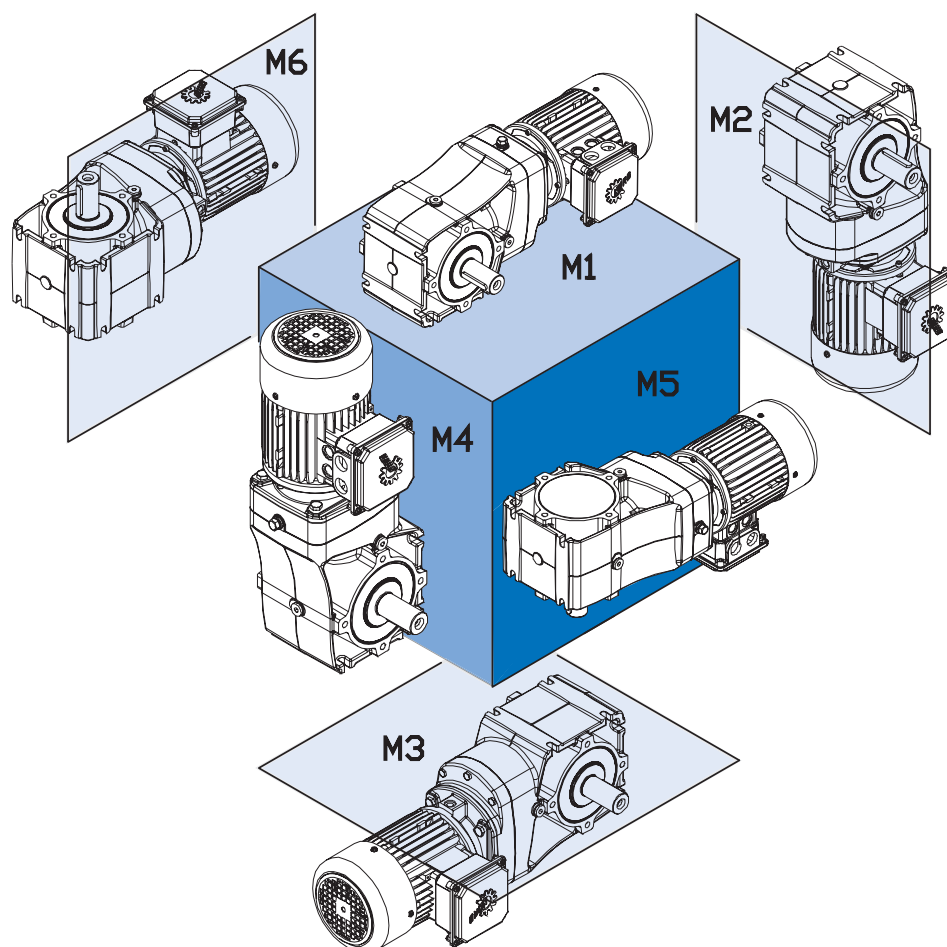

## Symbols for oil screw plugs in the mounting positions

Vent	Oil level	Oil drain

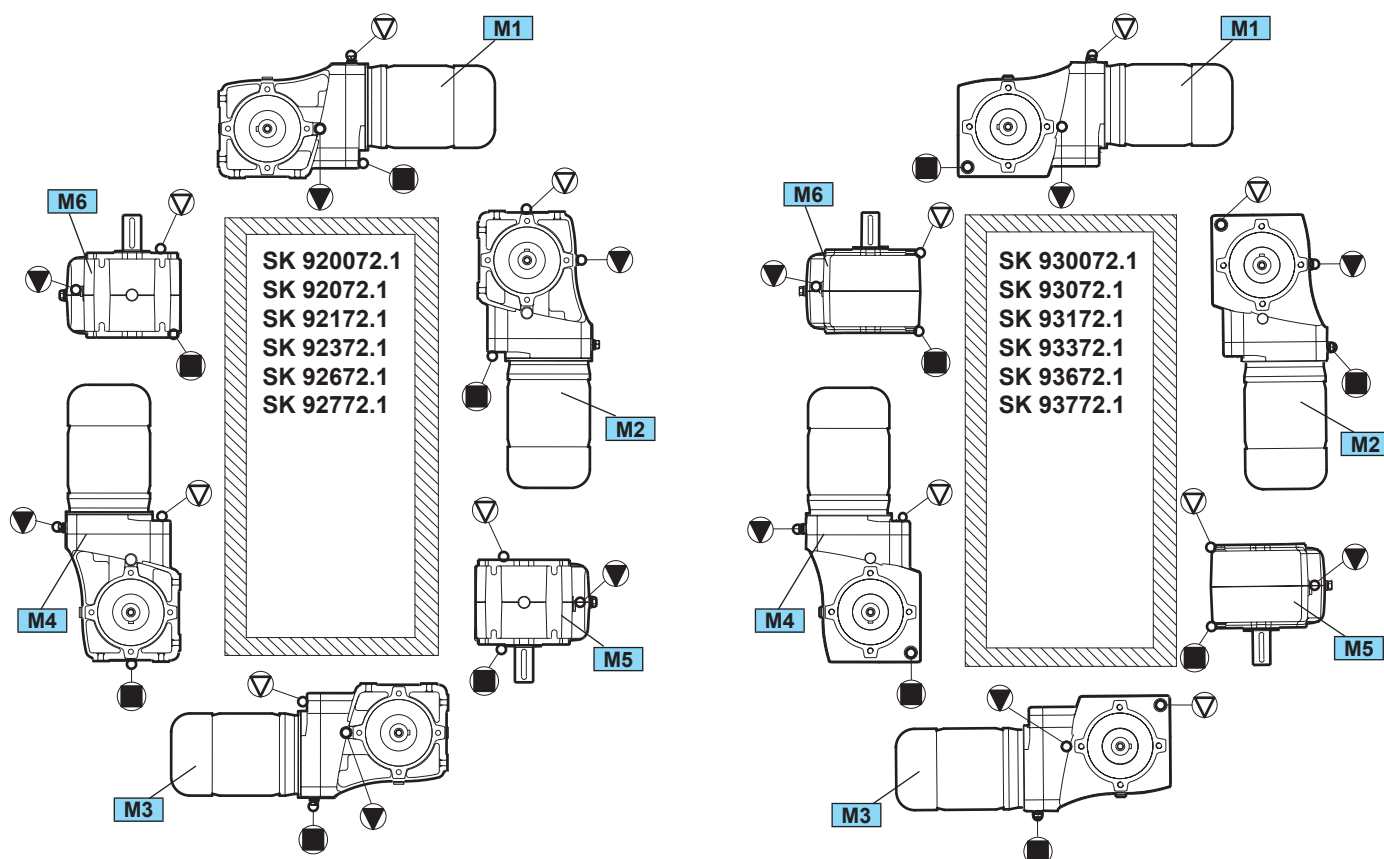

For the NORD gear unit series SK 92(x)72.1 it should be noted that for structural reasons, the shutter or venting screw can only be mounted on the side opposite to the motor and protrudes beyond the footprint.

Refer to the table below for the required clearings **d** and **h** of the respective gear size. This should be considered for the customer's connection design.

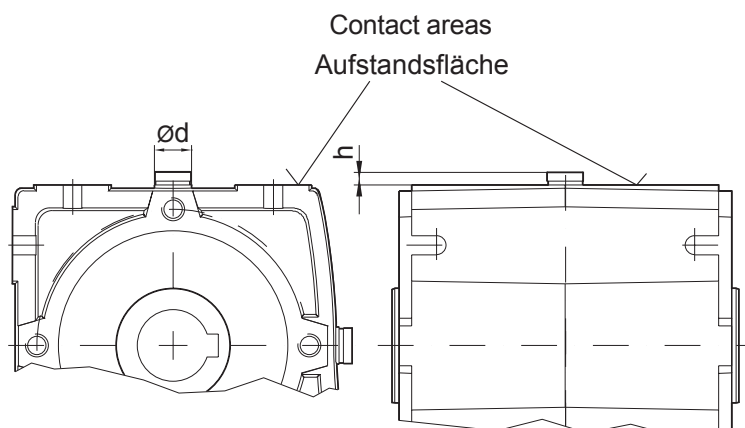

Gear unit	shutter / venting screw	Ød [mm]	h [mm]
SK 920072.1	M8 x 1,0	15	12
SK 92072.1	M8 x 1,0	15	12
SK 92172.1	M10 x 1,0	17	15
SK 92372.1	M12 x 1,5	21	15
SK 92672.1	M12 x 1,5	21	15
SK 92772.1	M12 x 1,5	21	15

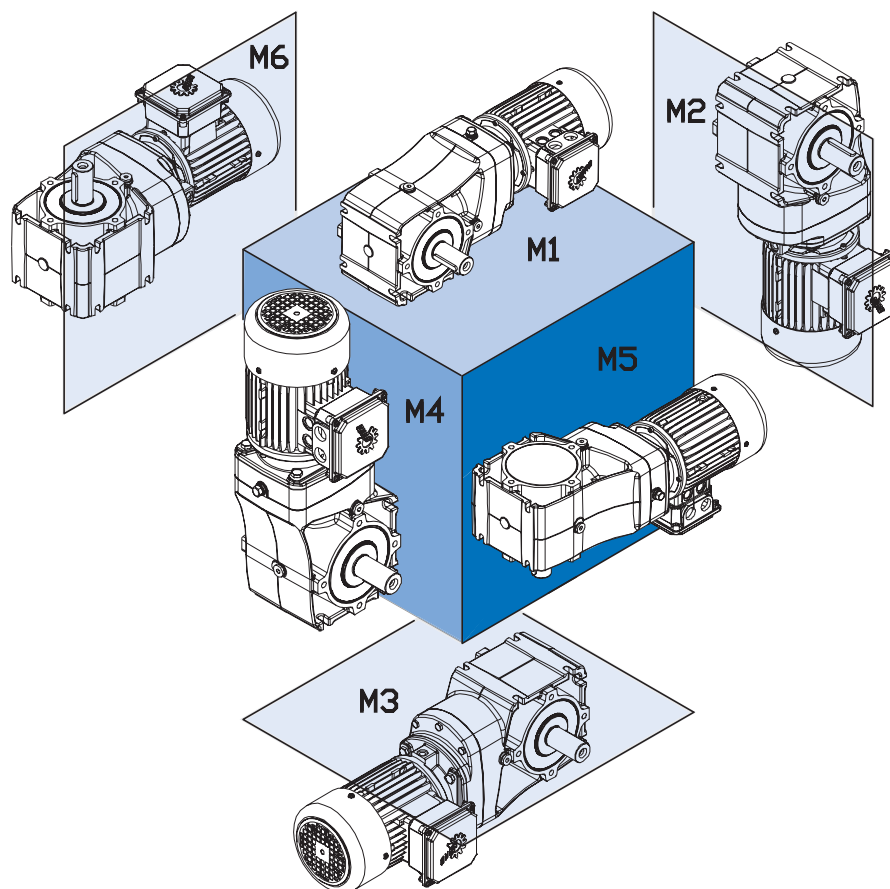

Type		 [L]					
		M1	M2	M3	M4	M5	M6
	SK 920072.1	0,210	0,470	0,360	0,340	0,280	0,280
	SK 92072.1	0,260	0,490	0,420	0,540	0,290	0,310
	SK 92172.1	0,340	0,610	0,520	0,670	0,420	0,480
	SK 92372.1	0,430	0,920	0,730	0,830	0,550	0,610
	SK 92672.1	0,850	1,60	1,20	1,50	1,02	1,02
	SK 92772.1	1,30	2,65	1,86	2,70	1,60	1,60
	SK 930072.1	0,280	0,650	0,560	0,540	0,390	0,390
	SK 93072.1	0,390	0,930	0,790	1,02	0,490	0,620
	SK 93172.1	0,600	1,17	0,940	1,22	0,650	0,850
	SK 93372.1	1,00	1,97	1,65	2,14	1,12	1,34
	SK 93672.1	1,80	3,23	2,71	3,80	2,02	2,45
	SK 93772.1	2,72	4,63	3,70	5,80	2,93	3,25

In the NORD gear units series SK 92x72.1 is important to note that a painting up to max. F2 (series) is possible. For the painting of the NORD gear unit series SK 93x72.1 there are no restrictions.

Type	TFD total [µm]	Similar to corrosivity category*	Recommended use
F1	60 - 100		For top-coat to be applied by customer
<b>F2 (Standard)</b>	50 - 90	C2	For indoor installation
F3.0	110 - 150	C2	"For indoor and protected outdoor installation with low environmental contamination, e.g. open, unheated halls"
F3.1	160 - 200	C3	For outdoor installation, city and industrial atmosphere with low contamination
F3.2	210 - 250	C4	For outdoor installation, city and industrial atmosphere with moderate environmental contamination
F3.3+Z	200 - 240	C5	For outdoor installation, city and industrial atmosphere with high environmental contamination
F3.4	100 - 140		For moderate exposure to chemicals
F3.5	100 - 140		Machinery for foodstuffs packaging
A			additional antimicrobial coating for all finishes except F3.4 and F3.5
Z			Compensation of contour depressions and crevices with seam sealer on polyurethane basis

\* to DIN EN ISO 12944-2 classification of ambient conditions



# 2-stage bevel helical gear unit

Series **SK 920072.1 - SK 92772.1**

**SK 930072.1 - SK 93772.1**

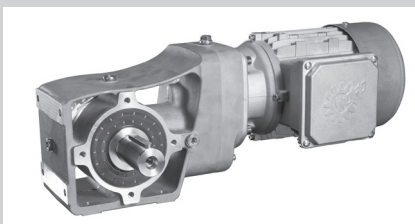

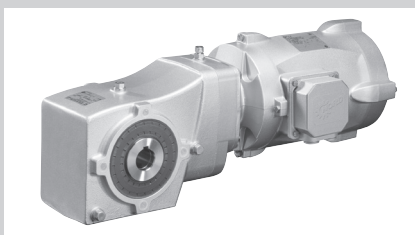

## GEAR UNIT MOTOR DATA

Power and speed tables .....	B - 2
Power and speed tables	
W- and IEC adapters .....	B - 13

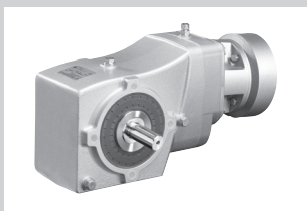
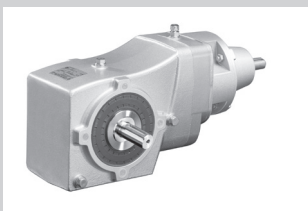
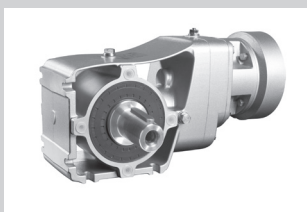
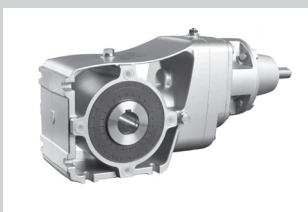

## DIMENSIONED DRAWINGS

Gear units .....	B - 20
W- and IEC adapters .....	B - 45
Option - Gearbox-foot mounting .....	B - 57

$F_R$	$F_A$	$F_{RVL}$	$F_{AVL}$	Gear unit m
[kN]	[kN]	[kN]	[kN]	IE1 IE2
6,6	15,0	-	-	SK 92372.1 - 63 S/4
6,6	15,0	-	-	SK 93372.1 - 63 S/4
4,9	12,0	-	-	SK 92172.1 - 63 S/4
4,9	12,0	-	-	- 63 S/4

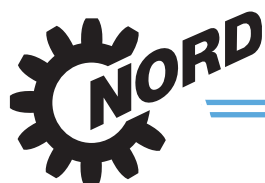
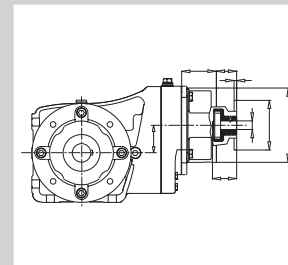

**0,12 kW**  
**0,18 kW**



P <sub>1</sub> [kW]	n <sub>2</sub> [min <sup>-1</sup> ]	M <sub>2</sub> [Nm]	f <sub>B</sub>	i <sub>ges</sub>	F <sub>R</sub> [kN]	F <sub>A</sub> [kN]	F <sub>RVL</sub> [kN]	F <sub>AVL</sub> [kN]	Gear unit motor			IE1 kg	mm mm
									IE1	IE2	IE3		
0,12	24	48	3,3	55,49	6,6	15,0	-	-	SK 92372.1 - 63 S/4		SK 92372.1 - 63 SP/4	16,1	B26-27
	27	42	3,3	49,46	6,6	15,0	-	-					
	19	60	1,2	70,00	4,9	12,0	-	-	SK 92172.1 - 63 S/4		SK 92172.1 - 63 SP/4	11,2	B24-25
	21	55	1,2	63,78	4,9	12,0	-	-					
	24	48	1,2	56,00	4,9	12,0	-	-					
	29	40	2,3	46,43	4,9	12,0	-	-					
	32	36	2,8	42,30	4,9	12,0	-	-					
	34	33	2,8	38,75	4,9	12,0	-	-					
	36	32	2,8	37,14	4,9	12,0	-	-					
	38	30	3,6	35,31	4,9	12,0	-	-					
	43	27	4,1	31,00	4,9	12,0	-	-					
	47	24	4,5	28,24	4,9	12,0	-	-					
	47	24	4,5	28,24	4,9	12,0	-	-					
	54	21	5,6	24,80	4,9	12,0	-	-					
	54	21	5,6	24,80	4,9	12,0	-	-					
	65	18	5,9	20,67	4,9	12,0	-	-					
	65	18	5,9	20,67	4,9	12,0	-	-					
	88	13	7,1	15,23	4,9	12,0	-	-					
	96	12	9,1	13,87	4,9	12,0	-	-					
									SK 93172.1 - 63 S/4		SK 93172.1 - 63 SP/4		B36-37
									SK 92072.1 - 63 S/4		SK 92072.1 - 63 SP/4	9,5	B22-23
22	53	1,1	61,88	5,0	9,0	-	-						
25	46	1,1	53,78	5,0	9,0	-	-						
28	41	1,1	47,67	5,0	9,0	-	-						
33	35	1,7	40,98	5,0	9,0	-	-						
37	31	2,1	35,62	5,0	9,0	-	-						
42	27	2,4	31,57	5,0	9,0	-	-						
49	23	2,8	27,16	5,0	9,0	-	-						
55	21	3,8	24,07	5,0	9,0	-	-						
64	18	4,5	20,80	5,0	9,0	-	-						
72	16	3,8	18,52	5,0	9,0	-	-						
83	14	4,8	16,00	5,0	9,0	-	-						
104	11	5,4	12,78	5,0	9,0	-	-						
120	10	6,8	11,11	5,0	9,0	-	-						
136	8	9,0	9,85	5,0	9,0	-	-						
154	7	9,9	8,67	5,0	9,0	-	-						
176	7	11,1	7,58	5,0	9,0	-	-						
200	6	11,9	6,67	5,0	9,0	-	-						
229	5	14,4	5,83	5,0	9,0	-	-						
258	4	15,1	5,17	4,8	9,0	-	-						
287	4	16,3	4,65	4,6	8,8	-	-						
336	3	19,9	3,97	4,4	8,4	-	-						
373	3	21,5	3,58	4,3	8,1	-	-						
									SK 93072.1 - 63 S/4		SK 93072.1 - 63 SP/4		B34-35
									SK 920072.1 - 63 S/4		SK 920072.1 - 63 SP/4	8,0	B20-21
29	39,9	0,9	47,67	3,0	5,6	-	-						
33	34,8	1,1	41,56	3,0	5,6	-	-						
37	30,7	1,2	36,67	3,0	5,6	-	-						
43	26,4	1,4	31,57	3,0	5,6	-	-						
50	23,0	1,7	27,52	3,0	5,6	-	-						
56	20,3	2,2	24,29	3,0	5,6	-	-						
67	17,2	2,6	20,53	3,0	5,6	-	-						
74	15,5	3,2	18,52	3,0	5,6	-	-						
86	13,4	3,7	16,00	3,0	5,6	-	-						
101	11,3	4,4	13,53	3,0	5,6	-	-						
111	10,3	4,8	12,33	3,0	5,6	-	-						
									SK 930072.1 - 63 S/4		SK 930072.1 - 63 SP/4		B32-33
0,18	25	70	2,3	55,49	6,6	15,0	-	-	SK 92372.1 - 63 L/4		SK 92372.1 - 63 LP/4	16,7	B26-27
	27	63	2,3	49,46	6,6	15,0	-	-					
	29	59	3,1	46,64	6,6	15,0	-	-	SK 93372.1 - 63 L/4		SK 93372.1 - 63 LP/4	B38-39	
	33	52	3,5	41,46	6,6	15,0	-	-					

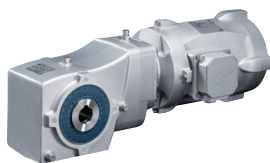
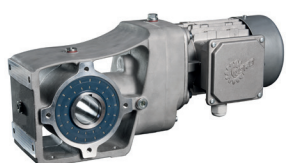

**0,18 kW**  
**0,25 kW**

P <sub>1</sub> [kW]	n <sub>2</sub> [min <sup>-1</sup> ]	M <sub>2</sub> [Nm]	f <sub>B</sub>	i <sub>ges</sub>	F <sub>R</sub> [kN]	F <sub>A</sub> [kN]	F <sub>RVL</sub> [kN]	F <sub>AVL</sub> [kN]	Gear unit motor			IE1 kg	mm mm				
									IE1 Standard	IE2	IE3						
0,18	19	88	0,8	70,00	4,8	12,0	-	-	SK 92172.1 - 63 L/4	SK 92172.1 - 63 LP/4	11,8	B24-25					
	21	81	0,8	63,78	4,8	12,0	-	-									
	24	71	0,8	56,00	4,8	12,0	-	-									
	29	59	1,6	46,43	4,9	12,0	-	-									
	32	53	1,9	42,30	4,9	12,0	-	-									
	35	49	1,9	38,75	4,9	12,0	-	-									
	37	47	1,9	37,14	4,9	12,0	-	-									
	39	45	2,4	35,31	4,9	12,0	-	-									
	44	39	2,8	31,00	4,9	12,0	-	-									
	48	36	3,0	28,24	4,9	12,0	-	-									
	55	31	3,8	24,80	4,9	12,0	-	-									
	66	26	4,0	20,67	4,9	12,0	-	-									
	89	19	4,8	15,23	4,9	12,0	-	-									
	98	18	6,2	13,87	4,9	12,0	-	-									
														SK 93172.1 - 63 L/4	SK 93172.1 - 63 LP/4		B36-37
		22	78	0,8	61,88	5,0	9,0	-					-	SK 92072.1 - 63 L/4	SK 92072.1 - 63 LP/4	10,1	B22-23
		25	68	0,8	53,78	5,0	9,0	-					-				
		29	60	0,8	47,67	5,0	9,0	-					-				
		33	52	1,1	40,98	5,0	9,0	-					-				
	38	45	1,4	35,62	5,0	9,0	-	-									
	43	40	1,6	31,57	5,0	9,0	-	-									
	50	34	1,9	27,16	5,0	9,0	-	-									
	56	30	2,6	24,07	5,0	9,0	-	-									
	65	26	3,1	20,80	5,0	9,0	-	-									
	73	23	2,6	18,52	5,0	9,0	-	-									
	85	20	3,3	16,00	5,0	9,0	-	-									
	106	16	3,7	12,78	5,0	9,0	-	-									
	122	14	4,6	11,11	5,0	9,0	-	-									
	138	12	6,1	9,85	5,0	9,0	-	-									
	157	11	6,8	8,67	5,0	9,0	-	-									
	180	10	7,5	7,58	5,0	9,0	-	-									
	204	8	8,1	6,67	5,0	9,0	-	-									
	233	7	9,8	5,83	4,9	9,0	-	-									
	263	7	10,3	5,17	4,7	9,0	-	-									
	292	6	11,0	4,65	4,6	8,7	-	-									
	342	5	13,5	3,97	4,4	8,3	-	-									
	380	5	14,6	3,58	4,2	8,0	-	-									
									SK 93072.1 - 63 L/4	SK 93072.1 - 63 LP/4		B34-35					
	38	45,5	0,8	36,67	3,0	5,6	-	-	SK 920072.1 - 63 L/4	SK 920072.1 - 63 LP/4	8,6	B20-21					
	44	39,2	1,0	31,57	3,0	5,6	-	-									
	50	34,2	1,2	27,52	3,0	5,6	-	-									
	57	30,1	1,5	24,29	3,0	5,6	-	-									
	67	25,5	1,8	20,53	3,0	5,6	-	-									
	75	23,0	2,2	18,52	3,0	5,6	-	-									
	87	19,9	2,5	16,00	3,0	5,6	-	-									
	102	16,8	3,0	13,53	3,0	5,6	-	-									
	112	15,3	3,3	12,33	3,0	5,6	-	-									
	133	12,9	3,9	10,43	3,0	5,6	-	-									
													SK 930072.1 - 63 L/4	SK 930072.1 - 63 LP/4		B32-33	
0,25	21	116	4,2	66,96	10,4	25,0	-	-	SK 92772.1 - 71 S/4	SK 92772.1 - 71 SP/4	40,2	B30-31					
	23	103	4,2	59,68	10,4	25,0	-	-									
										SK 93772.1 - 71 S/4	SK 93772.1 - 71 SP/4		B42-43				
	28	84	3,8	48,56	8,4	20,0	-	-	SK 92672.1 - 71 S/4	SK 92672.1 - 71 SP/4	28,8	B28-29					
									SK 93672.1 - 71 S/4	SK 93672.1 - 71 SP/4		B40-41					

**0,25 kW**  
**0,37 kW**



P <sub>1</sub> [kW]	n <sub>2</sub> [min <sup>-1</sup> ]	M <sub>2</sub> [Nm]	f <sub>B</sub>	i <sub>ges</sub>	F <sub>R</sub> [kN]	F <sub>A</sub> [kN]	F <sub>R VL</sub> [kN]	F <sub>A VL</sub> [kN]	Gear unit motor			IE1 kg	mm mm				
									IE1 Standard	IE2	IE3						
0,25	25	96	1,6	55,49	6,5	15,0	-	-	SK 92372.1 - 71 S/4		SK 92372.1 - 71 SP/4	17,9	B26-27				
	28	86	1,6	49,46	6,5	15,0	-	-									
	30	81	2,3	46,64	6,5	15,0	-	-									
	33	72	2,6	41,46	6,6	15,0	-	-									
	38	64	2,9	36,80	6,6	15,0	-	-									
	42	57	3,5	32,80	6,6	15,0	-	-	SK 93372.1 - 71 S/4		SK 93372.1 - 71 SP/4		B38-39				
	30	80	1,2	46,43	4,8	12,0	-	-									
	33	73	1,4	42,30	4,8	12,0	-	-	SK 92172.1 - 71 S/4		SK 92172.1 - 71 SP/4	13,0	B24-25				
	36	67	1,4	38,75	4,8	12,0	-	-									
	37	64	1,4	37,14	4,8	12,0	-	-									
	39	61	1,8	35,31	4,9	12,0	-	-									
	45	54	2,0	31,00	4,9	12,0	-	-									
	49	49	2,2	28,24	4,9	12,0	-	-									
	56	43	2,8	24,80	4,9	12,0	-	-									
67	36	2,9	20,67	4,9	12,0	-	-										
91	26	3,5	15,23	4,9	12,0	-	-										
99	24	4,5	13,87	4,9	12,0	-	-	SK 93172.1 - 71 S/4							SK 93172.1 - 71 SP/4		B36-37
34	71	0,8	40,98	5,0	9,0	-	-										
39	62	1,1	35,62	5,0	9,0	-	-	SK 92072.1 - 71 S/4							SK 92072.1 - 71 SP/4	11,3	B22-23
44	55	1,2	31,57	5,0	9,0	-	-										
51	47	1,4	27,16	5,0	9,0	-	-										
57	42	1,9	24,07	5,0	9,0	-	-										
66	36	2,3	20,80	5,0	9,0	-	-										
75	32	1,9	18,52	5,0	9,0	-	-										
86	28	2,4	16,00	5,0	9,0	-	-										
108	22	2,7	12,78	5,0	9,0	-	-										
124	19	3,4	11,11	5,0	9,0	-	-										
140	17	4,5	9,85	5,0	9,0	-	-										
159	15	4,9	8,67	5,0	9,0	-	-										
182	13	5,5	7,58	5,0	9,0	-	-										
207	12	5,9	6,67	5,0	9,0	-	-										
237	10	7,1	5,83	4,9	9,0	-	-										
267	9	7,5	5,17	4,7	8,9	-	-										
296	8	8,1	4,65	4,5	8,6	-	-										
347	7	9,9	3,97	4,3	8,2	-	-										
385	6	10,7	3,58	4,2	7,9	-	-		SK 93072.1 - 71 S/4		SK 93072.1 - 71 SP/4		B34-35				
51	46,4	0,9	27,52	3,0	5,6	-	-										
58	41,0	1,1	24,29	3,0	5,6	-	-	SK 920072.1 - 71 S/4		SK 920072.1 - 71 SP/4	9,8	B20-21					
69	34,6	1,3	20,53	3,0	5,6	-	-										
76	31,2	1,6	18,52	3,0	5,6	-	-										
88	27,0	1,9	16,00	3,0	5,6	-	-										
105	22,8	2,2	13,53	3,0	5,6	-	-										
115	20,8	2,4	12,33	3,0	5,6	-	-										
136	17,6	2,8	10,43	3,0	5,6	-	-										
158	15,1	3,3	8,97	3,0	5,6	-	-										
187	12,8	3,9	7,58	3,0	5,6	-	-										
212	11,2	4,4	6,67	3,0	5,6	-	-										
221	10,8	4,6	6,40	3,0	5,6	-	-										
251	9,5	4,7	5,64	3,0	5,6	-	-										
274	8,7	4,3	5,17	3,0	5,6	-	-						SK 930072.1 - 71 S/4		SK 930072.1 - 71 SP/4		B32-33
0,37	21	171	2,9	66,96	10,3	25,0	-										
23	153	2,9	59,68	10,4	25,0	-	-						SK 92772.1 - 71 L/4			41,1	B26-27
								SK 93772.1 - 71 L/4				B36-37					
28	124	2,6	48,56	8,4	20,0	-	-										
32	111	2,8	43,28	8,4	20,0	-	-	SK 92672.1 - 71 L/4			29,7	B24-25					
79	45	7,1	17,46	8,5	20,0	-	-										
								SK 93672.1 - 71 L/4				B34-35					



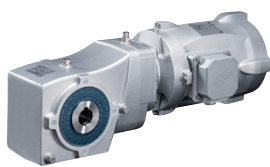
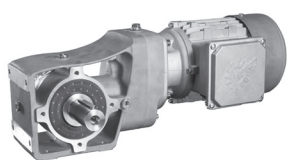

**0,37 kW**  
**0,55 kW**

P <sub>1</sub> [kW]	n <sub>2</sub> [min <sup>-1</sup> ]	M <sub>2</sub> [Nm]	f <sub>B</sub>	i <sub>ges</sub>	F <sub>R</sub> [kN]	F <sub>A</sub> [kN]	F <sub>RVL</sub> [kN]	F <sub>AVL</sub> [kN]	Gear unit motor			IE1 kg	mm mm
									IE1	IE2	IE3		
0,37	25	142	1,1	55,49	6,4	15,0	-	-	SK 92372.1 - 71 L/4		SK 92372.1 - 71 LP/4	18,8	B26-27
	28	127	1,1	49,46	6,4	15,0	-	-					
	30	119	1,5	46,64	6,4	15,0	-	-					
	33	106	1,7	41,46	6,5	15,0	-	-					
	38	94	2,0	36,80	6,5	15,0	-	-					
	42	84	2,4	32,80	6,5	15,0	-	-	SK 93372.1 - 71 L/4		SK 93372.1 - 71 LP/4	B38-39	
	36	99	0,9	38,75	4,7	12,0	-	-					
	39	90	1,2	35,31	4,7	12,0	-	-					
	45	79	1,4	31,00	4,8	12,0	-	-					
	49	72	1,5	28,24	4,8	12,0	-	-					
56	63	1,9	24,80	4,8	12,0	-	-	SK 92172.1 - 71 L/4		SK 92172.1 - 71 LP/4	13,9	B24-25	
67	53	2,0	20,67	4,9	12,0	-	-						
91	39	2,4	15,23	4,9	12,0	-	-						
99	36	3,0	13,87	4,9	12,0	-	-						
112	32	3,4	12,34	4,9	12,0	-	-						
113	31	3,7	12,18	4,9	12,0	-	-	SK 93172.1 - 71 L/4		SK 93172.1 - 71 LP/4	B36-37		
51	70	0,9	27,16	5,0	9,0	-	-						
57	62	1,3	24,07	5,0	9,0	-	-						
66	53	1,5	20,80	5,0	9,0	-	-						
75	47	1,3	18,52	5,0	9,0	-	-						
86	41	1,6	16,00	5,0	9,0	-	-	SK 92072.1 - 71 L/4		SK 92072.1 - 71 LP/4	12,2	B22-23	
108	33	1,8	12,78	5,0	9,0	-	-						
124	28	2,3	11,11	5,0	9,0	-	-						
140	25	3,0	9,85	5,0	9,0	-	-						
159	22	3,3	8,67	5,0	9,0	-	-						
182	19	3,7	7,58	5,0	9,0	-	-	SK 93072.1 - 71 L/4		SK 93072.1 - 71 LP/4	B34-35		
207	17	4,0	6,67	5,0	9,0	-	-						
237	15	4,8	5,83	4,8	9,0	-	-						
267	13	5,1	5,17	4,6	8,7	-	-						
296	12	5,5	4,65	4,5	8,5	-	-						
347	10	6,7	3,97	4,3	8,1	-	-	SK 920072.1 - 71 L/4		SK 920072.1 - 71 LP/4	10,7	B20-21	
385	9	7,2	3,58	4,1	7,8	-	-						
76	46,6	1,1	18,52	3,0	5,6	-	-						
88	40,2	1,2	16,00	3,0	5,6	-	-						
104	34,0	1,5	13,53	3,0	5,6	-	-						
114	31,0	1,6	12,33	3,0	5,6	-	-	SK 930072.1 - 71 L/4		SK 930072.1 - 71 LP/4	B32-33		
135	26,2	1,9	10,43	3,0	5,6	-	-						
157	22,6	2,2	8,97	3,0	5,6	-	-						
185	19,1	2,6	7,58	3,0	5,6	-	-						
211	16,8	3,0	6,67	3,0	5,6	-	-						
219	16,1	3,1	6,40	3,0	5,6	-	-	SK 92772.1 - 80 S/4	SK 92772.1 - 80 SH/4	43,8	B30-31		
249	14,2	3,2	5,64	3,0	5,6	-	-						
272	13,0	2,9	5,17	3,0	5,6	-	-						
312	11,3	3,5	4,50	3,0	5,6	-	-						
354	10,0	4,0	3,97	3,0	5,6	-	-						
418	8,4	4,7	3,36	3,0	5,6	-	-	SK 93772.1 - 80 S/4	SK 93772.1 - 80 SH/4	B42-43			
76	46,6	1,1	18,52	3,0	5,6	-	-						
88	40,2	1,2	16,00	3,0	5,6	-	-						
104	34,0	1,5	13,53	3,0	5,6	-	-						
114	31,0	1,6	12,33	3,0	5,6	-	-						
135	26,2	1,9	10,43	3,0	5,6	-	-	SK 92672.1 - 80 S/4	SK 92672.1 - 80 SH/4	32,4	B28-29		
157	22,6	2,2	8,97	3,0	5,6	-	-						
185	19,1	2,6	7,58	3,0	5,6	-	-						
211	16,8	3,0	6,67	3,0	5,6	-	-						
219	16,1	3,1	6,40	3,0	5,6	-	-						
249	14,2	3,2	5,64	3,0	5,6	-	-	SK 93672.1 - 80 S/4	SK 93672.1 - 80 SH/4	B38-39			
272	13,0	2,9	5,17	3,0	5,6	-	-						
312	11,3	3,5	4,50	3,0	5,6	-	-						
354	10,0	4,0	3,97	3,0	5,6	-	-						
418	8,4	4,7	3,36	3,0	5,6	-	-						

**0,55 kW**  
**0,75 kW**



P <sub>1</sub> [kW]	n <sub>2</sub> IE2 [min <sup>-1</sup> ]	M <sub>2</sub> [Nm]	f <sub>B</sub>	i <sub>ges</sub>	F <sub>R</sub> [kN]	F <sub>A</sub> [kN]	F <sub>R VL</sub> [kN]	F <sub>A VL</sub> [kN]	Gear unit motor			IE2 kg	mm mm
									IE1	IE2	IE3		
<b>0,55</b>	30	173	1,1	46,64	6,2	15,0	-	-	SK 92372.1 - 80 S/4	SK 92372.1 - 80 SH/4		21,5	B26-27
	34	153	1,2	41,46	6,3	15,0	-	-					
	39	136	1,4	36,80	6,4	15,0	-	-					
	43	121	1,6	32,80	6,4	15,0	-	-					
	51	104	1,8	28,11	6,5	15,0	-	-					
	57	93	2,4	25,06	6,5	15,0	-	-					
	63	83	2,2	22,49	6,5	15,0	-	-					
	71	74	3,0	20,04	6,5	15,0	-	-					
	77	68	2,7	18,33	6,6	15,0	-	-					
	90	59	3,1	15,84	6,6	15,0	-	-					
	101	52	4,2	14,12	6,6	15,0	-	-	SK 93372.1 - 80 S/4	SK 93372.1 - 80 SH/4			B38-39
	50	104	1,0	28,24	4,7	12,0	-	-	SK 92172.1 - 80 S/4	SK 92172.1 - 80 SH/4		16,6	B24-25
	57	92	1,3	24,80	4,7	12,0	-	-					
	69	76	1,4	20,67	4,8	12,0	-	-					
	93	56	1,7	15,23	4,9	12,0	-	-					
	102	51	2,1	13,87	4,9	12,0	-	-					
	115	46	2,4	12,34	4,9	12,0	-	-					
	117	45	2,5	12,18	4,9	12,0	-	-					
	131	40	2,8	10,83	4,9	12,0	-	-					
	140	38	2,5	10,15	4,9	12,0	-	-	SK 93172.1 - 80 S/4	SK 93172.1 - 80 SH/4			B36-37
	68	77	1,1	20,80	5,0	9,0	-	-	SK 92072.1 - 80 S/4	SK 92072.1 - 80 SH/4		14,9	B22-23
	89	59	1,1	16,00	5,0	9,0	-	-					
	111	47	1,2	12,78	5,0	9,0	-	-					
	128	41	1,6	11,11	5,0	9,0	-	-					
	144	36	2,1	9,85	5,0	9,0	-	-					
	164	32	2,3	8,67	5,0	9,0	-	-					
	187	28	2,6	7,58	5,0	9,0	-	-					
	213	25	2,8	6,67	4,8	9,0	-	-					
	244	22	3,3	5,83	4,7	8,8	-	-					
	275	19	3,5	5,17	4,5	8,5	-	-					
	305	17	3,8	4,65	4,4	8,2	-	-					
	357	15	4,6	3,97	4,2	7,8	-	-					
	397	13	5,0	3,58	4,0	7,6	-	-	SK 93072.1 - 80 S/4	SK 93072.1 - 80 SH/4			B34-35
	89	59,2	0,8	16,00	3,0	5,6	-	-	SK 920072.1 - 80 S/4	SK 920072.1 - 80 SH/4	SK 920072.1 - 80 SP/4	13,6	B20-21
	105	50,0	1,0	13,53	3,0	5,6	-	-					
	115	45,6	1,1	12,33	3,0	5,6	-	-					
	136	38,6	1,3	10,43	3,0	5,6	-	-					
	158	33,2	1,5	8,97	3,0	5,6	-	-					
	187	28,0	1,8	7,58	3,0	5,6	-	-					
	213	24,7	2,0	6,67	3,0	5,6	-	-					
	222	23,7	2,1	6,40	3,0	5,6	-	-					
	252	20,8	2,2	5,64	3,0	5,6	-	-					
	275	19,1	2,0	5,17	3,0	5,6	-	-					
	315	16,7	2,4	4,50	3,0	5,6	-	-					
	357	14,7	2,7	3,97	3,0	5,6	-	-					
	423	12,4	3,2	3,36	3,0	5,6	-	-					
	469	11,2	3,6	3,03	3,0	5,6	-	-	SK 930072.1 - 80 S/4	SK 930072.1 - 80 SH/4	SK 930072.1 - 80 SP/4		B32-33
<b>0,75</b>	21	339	1,4	66,96	10,0	25,0	-	-	SK 92772.1 - 80 L/4	SK 92772.1 - 80 LH/4	SK 92772.1 - 80 LP/4	45,0	B30-31
	24	302	1,4	59,68	10,1	25,0	-	-					
	27	266	2,2	52,64	10,1	25,0	-	-					
	30	237	2,2	46,92	10,2	25,0	-	-					
	33	220	2,9	43,44	10,2	25,0	-	-					
	51	140	4,5	27,65	10,4	25,0	-	-					
	56	128	4,9	25,34	10,4	25,0	-	-					
	57	125	5,3	24,64	10,4	25,0	-	-					
	63	114	5,7	22,59	10,4	25,0	-	-					
	67	107	5,9	21,14	10,4	25,0	-	-	SK 93772.1 - 80 L/4	SK 93772.1 - 80 LH/4	SK 93772.1 - 80 LP/4		B42-43



**0,75 kW**

P <sub>1</sub> [kW]	n <sub>2</sub> [min <sup>-1</sup> ]	M <sub>2</sub> [Nm]	f <sub>B</sub>	i <sub>ges</sub>	F <sub>R</sub> [kN]	F <sub>A</sub> [kN]	F <sub>R VL</sub> [kN]	F <sub>A VL</sub> [kN]	Gear unit motor			IE2 kg	mm mm			
									IE1	IE2	IE3					
0,75	29	246	1,3	48,56	8,0	20,0	-	-	SK 92672.1 - 80 L/4	SK 92672.1 - 80 LH/4	SK 92672.1 - 80 LP/4	33,6	B28-29			
	33	219	1,4	43,28	8,1	20,0	-	-								
	37	191	1,7	37,82	8,2	20,0	-	-								
	42	171	2,1	33,71	8,3	20,0	-	-								
	46	155	2,0	30,67	8,3	20,0	-	-								
	52	138	2,6	27,33	8,3	20,0	-	-								
	71	101	3,1	20,00	8,4	20,0	-	-								
	81	88	3,6	17,46	8,4	20,0	-	-								
									SK 93672.1 - 80 L/4	SK 93672.1 - 80 LH/4	SK 93672.1 - 80 LP/4				B40-41	
	34	210	0,9	41,46	6,0	15,0	-	-	SK 92372.1 - 80 L/4	SK 92372.1 - 80 LH/4	SK 92372.1 - 80 LP/4	22,7	B26-27			
	38	186	1,0	36,80	6,2	15,0	-	-								
	43	166	1,2	32,80	6,3	15,0	-	-								
	50	142	1,3	28,11	6,4	15,0	-	-								
	56	127	1,7	25,06	6,4	15,0	-	-								
	63	114	1,6	22,49	6,5	15,0	-	-								
	71	101	2,2	20,04	6,5	15,0	-	-								
	77	93	2,0	18,33	6,5	15,0	-	-								
	89	80	2,3	15,84	6,5	15,0	-	-								
	100	71	3,0	14,12	6,6	15,0	-	-								
	113	64	2,9	12,56	6,6	15,0	-	-								
	126	57	3,8	11,20	6,6	15,0	-	-								
	137	52	4,2	10,33	6,6	15,0	-	-								
									SK 93372.1 - 80 L/4	SK 93372.1 - 80 LH/4	SK 93372.1 - 80 LP/4				B38-39	
	50	143	0,8	28,24	4,4	12,0	-	-	SK 92172.1 - 80 L/4	SK 92172.1 - 80 LH/4	SK 92172.1 - 80 LP/4	17,8	B24-25			
	57	126	1,0	24,80	4,5	12,0	-	-								
	68	105	1,0	20,67	4,7	12,0	-	-								
	93	77	1,2	15,23	4,8	12,0	-	-								
	102	70	1,5	13,87	4,8	12,0	-	-								
	115	62	1,7	12,34	4,9	12,0	-	-								
	116	62	1,8	12,18	4,9	12,0	-	-								
	131	55	2,1	10,83	4,9	12,0	-	-								
	139	51	1,8	10,15	4,9	11,9	-	-								
	149	48	2,2	9,49	4,9	11,8	-	-								
	157	46	2,1	9,03	4,9	11,6	-	-								
	170	42	2,7	8,33	4,9	11,3	-	-								
	181	40	2,8	7,83	4,9	11,2	-	-								
	204	35	3,1	6,94	4,9	10,8	-	-								
									SK 93172.1 - 80 L/4	SK 93172.1 - 80 LH/4	SK 93172.1 - 80 LP/4		B36-37			
	68	105	0,8	20,80	4,9	9,0	-	-	SK 92072.1 - 80 L/4	SK 92072.1 - 80 LH/4	SK 92072.1 - 80 LP/4	16,1	B22-23			
	88	81	0,8	16,00	5,0	9,0	-	-								
	111	65	0,9	12,78	5,0	9,0	-	-								
	127	56	1,2	11,11	5,0	9,0	-	-								
	144	50	1,5	9,85	5,0	9,0	-	-								
	163	44	1,7	8,67	5,0	9,0	-	-								
	187	38	1,9	7,58	4,9	9,0	-	-								
	212	34	2,0	6,67	4,7	8,8	-	-								
	243	30	2,4	5,83	4,5	8,6	-	-								
	274	26	2,6	5,17	4,4	8,3	-	-								
	304	24	2,8	4,65	4,3	8,1	-	-								
	356	20	3,4	3,97	4,1	7,7	-	-								
	395	18	3,6	3,58	4,0	7,5	-	-								
									SK 93072.1 - 80 L/4	SK 93072.1 - 80 LH/4	SK 93072.1 - 80 LP/4				B34-35	
	115	62,4	0,8	12,33	3,0	5,6	-	-	SK 920072.1 - 80 L/4	SK 920072.1 - 80 LH/4	SK 920072.1 - 80 LP/4	14,6	B20-21			
	136	52,8	0,9	10,43	3,0	5,6	-	-								
	158	45,4	1,1	8,97	3,0	5,6	-	-								
	187	38,3	1,3	7,58	3,0	5,6	-	-								
	212	33,7	1,5	6,67	3,0	5,6	-	-								
	221	32,4	1,5	6,40	3,0	5,6	-	-								
	251	28,5	1,6	5,64	3,0	5,6	-	-								
	274	26,2	1,4	5,17	3,0	5,6	-	-								
	314	22,8	1,8	4,50	3,0	5,6	-	-								
	356	20,1	2,0	3,97	3,0	5,6	-	-								
	421	17,0	2,4	3,36	3,0	5,6	-	-								
	467	15,3	2,6	3,03	3,0	5,6	-	-								
									SK 930072.1 - 80 L/4	SK 930072.1 - 80 LH/4	SK 930072.1 - 80 LP/4				B32-33	

# 1,10 kW



P <sub>1</sub> [kW]	n <sub>2</sub> IE2 [min <sup>-1</sup> ]	M <sub>2</sub> [Nm]	f <sub>B</sub>	i <sub>ges</sub>	F <sub>R</sub> [kN]	F <sub>A</sub> [kN]	F <sub>RVL</sub> [kN]	F <sub>AVL</sub> [kN]	Gear unit motor			IE2 kg	mm 			
									IE1 	IE2 	IE3 					
1,10	21	490	1,0	66,96	9,4	25,0	-	-	SK 92772.1 - 90 S/4	SK 92772.1 - 90 SH/4	SK 92772.1 - 90 SP/4	49,9	B30-31			
	24	437	1,0	59,68	9,6	25,0	-	-								
	27	385	1,5	52,64	9,8	25,0	-	-								
	31	343	1,5	46,92	9,9	25,0	-	-								
	33	318	2,0	43,44	10,0	25,0	-	-								
	36	288	2,2	39,32	10,1	25,0	-	-								
	41	257	2,6	35,04	10,2	25,0	-	-								
	52	202	3,1	27,65	10,3	25,0	-	-								
	57	186	3,4	25,34	10,3	25,0	-	-								
	58	180	3,6	24,64	10,3	25,0	-	-								
	64	165	3,9	22,59	10,3	25,0	-	-								
	68	155	4,1	21,14	10,4	25,0	-	-								
										SK 93772.1 - 90 S/4	SK 93772.1 - 90 SH/4			SK 92772.1 - 90 SP/4		B42-43
		30	355	0,9	48,56	7,5	20,0	-	-	SK 92672.1 - 90 S/4	SK 92672.1 - 90 SH/4			SK 92672.1 - 90 SP/4	38,5	B28-29
	33	317	1,0	43,28	7,7	20,0	-	-								
	38	277	1,1	37,82	7,9	20,0	-	-								
	43	247	1,5	33,71	8,0	20,0	-	-								
	47	224	1,4	30,67	8,1	20,0	-	-								
	52	200	1,8	27,33	8,2	20,0	-	-								
	58	182	2,0	24,88	8,2	20,0	-	-								
	72	146	2,1	20,00	8,3	20,0	-	-								
	79	133	2,6	18,21	8,3	20,0	-	-								
	82	128	2,5	17,46	8,4	20,0	-	-								
	92	114	3,2	15,56	8,4	20,0	-	-								
	100	105	3,0	14,40	8,4	20,0	-	-								
									SK 93672.1 - 90 S/4	SK 93672.1 - 90 SH/4	SK 93672.1 - 90 SP/4		B40-41			
	44	240	0,8	32,80	5,8	15,0	-	-	SK 92372.1 - 90 S/4	SK 92372.1 - 90 SH/4	SK 92372.1 - 90 SP/4	27,6	B26-27			
	51	206	0,9	28,11	6,1	15,0	-	-								
	57	183	1,2	25,06	6,2	15,0	-	-								
	64	165	1,1	22,49	6,3	15,0	-	-								
	72	147	1,5	20,04	6,3	15,0	-	-								
	78	134	1,4	18,33	6,4	15,0	-	-								
	91	116	1,6	15,84	6,4	15,0	-	-								
	102	103	2,1	14,12	6,5	15,0	-	-								
	114	92	2,0	12,56	6,5	15,0	-	-								
	128	82	2,7	11,20	6,5	15,0	-	-								
	139	76	2,9	10,33	6,5	15,0	-	-								
	158	67	3,3	9,11	6,6	15,0	-	-								
	175	60	3,5	8,19	6,6	15,0	-	-								
	205	51	3,9	7,01	6,6	15,0	-	-								
	215	49	4,2	6,67	6,6	15,0	-	-								
	246	43	4,4	5,83	6,6	14,7	-	-								
									SK 93372.1 - 90 S/4	SK 93372.1 - 90 SH/4	SK 93372.1 - 90 SP/4		B38-39			
	151	69	1,5	9,49	4,8	11,2	-	-	SK 92172.1 - 90 S/4	SK 92172.1 - 90 SH/4	SK 92172.1 - 90 SP/4	22,7	B24-25			
	172	61	1,9	8,33	4,9	10,8	-	-								
	183	57	1,9	7,83	4,9	10,7	-	-								
	207	51	2,2	6,94	4,9	10,3	-	-								
	220	48	1,9	6,53	4,9	10,2	-	-								
	249	42	2,2	5,77	4,9	9,9	-	-								
	273	38	2,8	5,26	4,9	9,6	-	-								
	293	36	3,0	4,89	4,9	9,4	-	-								
	334	31	3,4	4,30	4,9	8,9	-	-								
									SK 93172.1 - 90 S/4	SK 93172.1 - 90 SH/4	SK 93172.1 - 90 SP/4				B36-37	
	246	43	1,7	5,83	4,3	8,2	-	-	SK 92072.1 - 90 S/4	SK 92072.1 - 90 SH/4	SK 92072.1 - 90 SP/4			21,0	B22-23	
	278	38	1,8	5,17	4,2	7,9	-	-								
	308	34	1,9	4,65	4,1	7,7	-	-								
	361	29	2,3	3,97	4,0	7,4	-	-								
	401	26	2,5	3,58	3,8	7,2	-	-								
									SK 93072.1 - 90 S/4	SK 93072.1 - 90 SH/4	SK 93072.1 - 90 SP/4		B34-35			

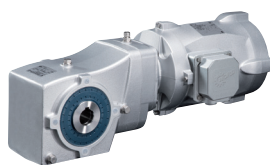
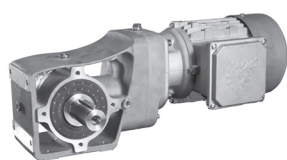

# 1,50 kW

P <sub>1</sub> [kW]	n <sub>2</sub> [min <sup>-1</sup> ]	M <sub>2</sub> [Nm]	f <sub>B</sub>	i <sub>ges</sub>	F <sub>R</sub> [kN]	F <sub>A</sub> [kN]	F <sub>R VL</sub> [kN]	F <sub>A VL</sub> [kN]	Gear unit motor			IE2 kg	mm mm					
									IE1	IE2	IE3							
1,50	27	533	1,1	52,64	9,1	25,0	-	-	SK 92772.1 - 90 L/4	SK 92772.1 - 90 LH/4	SK 92772.1 - 90 LP/4	51,6	B30-31					
	30	475	1,1	46,92	9,4	25,0	-	-										
	33	440	1,4	43,44	9,6	25,0	-	-										
	36	398	1,6	39,32	9,8	25,0	-	-										
	40	355	1,9	35,04	9,9	25,0	-	-										
	51	280	2,3	27,65	10,1	25,0	-	-										
	56	257	2,5	25,34	10,2	25,0	-	-										
	57	249	2,6	24,64	10,2	25,0	-	-										
	63	229	2,8	22,59	10,2	25,0	-	-										
	67	214	2,9	21,14	10,3	25,0	-	-										
	74	194	3,2	19,17	10,3	25,0	-	-										
	75	191	3,4	18,84	10,3	25,0	-	-										
	83	173	3,7	17,08	10,3	25,0	-	-										
									SK 93772.1 - 90 L/4	SK 93772.1 - 90 LH/4	SK 93772.1 - 90 LP/4		B42-43					
	37	383	0,8	37,82	7,4	20,0	-	-	SK 92672.1 - 90 L/4	SK 92672.1 - 90 LH/4	SK 92672.1 - 90 LP/4	40,2	B28-29					
	42	341	1,1	33,71	7,6	20,0	-	-										
	46	310	1,0	30,67	7,8	20,0	-	-										
	52	277	1,3	27,33	7,9	20,0	-	-										
	57	252	1,4	24,88	8,0	20,0	-	-										
	71	202	1,5	20,00	8,2	20,0	-	-										
	78	184	1,9	18,21	8,2	20,0	-	-										
	81	177	1,8	17,46	8,3	20,0	-	-										
	91	158	2,3	15,56	8,3	20,0	-	-										
	98	146	2,2	14,40	8,3	20,0	-	-										
	110	130	2,8	12,84	8,4	20,0	-	-										
	124	115	3,1	11,39	8,4	20,0	-	-										
														SK 93672.1 - 90 L/4	SK 93672.1 - 90 LH/4	SK 93672.1 - 90 LP/4		B40-41
	56	254	0,9	25,06	5,7	15,0	-	-	SK 92372.1 - 90 L/4	SK 92372.1 - 90 LH/4	SK 92372.1 - 90 LP/4	29,3	B26-27					
	63	228	0,8	22,49	5,9	15,0	-	-										
	71	203	1,1	20,04	6,1	15,0	-	-										
	77	186	1,0	18,33	6,2	15,0	-	-										
	89	160	1,1	15,84	6,3	15,0	-	-										
	100	143	1,5	14,12	6,4	15,0	-	-										
	113	127	1,4	12,56	6,4	15,0	-	-										
	126	113	1,9	11,20	6,5	15,0	-	-										
	137	105	2,1	10,33	6,5	15,0	-	-										
	155	92	2,4	9,11	6,5	15,0	-	-										
	173	83	2,5	8,19	6,5	15,0	-	-										
	202	71	2,8	7,01	6,6	15,0	-	-										
	212	67	3,0	6,67	6,6	15,0	-	-										
	243	59	3,2	5,83	6,6	14,4	-	-										
									SK 93372.1 - 90 L/4	SK 93372.1 - 90 LH/4	SK 93372.1 - 90 LP/4		B38-39					
	149	96	1,1	9,49	4,7	10,6	-	-	SK 92172.1 - 90 L/4	SK 92172.1 - 90 LH/4	SK 92172.1 - 90 LP/4	24,4	B24-25					
	170	84	1,4	8,33	4,8	10,3	-	-										
	181	79	1,4	7,83	4,8	10,2	-	-										
	204	70	1,6	6,94	4,8	9,9	-	-										
	217	66	1,4	6,53	4,8	9,7	-	-										
	245	58	1,6	5,77	4,9	9,6	-	-										
	269	53	2,0	5,26	4,9	9,3	-	-										
	289	50	2,2	4,89	4,9	9,1	-	-										
	329	43	2,4	4,30	4,9	8,6	-	-										
	368	39	2,3	3,85	4,8	8,1	-	-										
	395	36	2,4	3,58	4,7	7,9	-	-										
														SK 93172.1 - 90 L/4	SK 93172.1 - 90 LH/4	SK 93172.1 - 90 LP/4		B36-37

# 2,20 kW 3,00 kW



P <sub>1</sub> [kW]	n <sub>2</sub> [min <sup>-1</sup> ]	M <sub>2</sub> [Nm]	f <sub>B</sub>	i <sub>ges</sub>	F <sub>R</sub> [kN]	F <sub>A</sub> [kN]	F <sub>RVL</sub> [kN]	F <sub>AVL</sub> [kN]	Gear unit motor			IE2 kg	mm mm					
									IE1	IE2	IE3							
2,20	37	572	1,1	39,32	8,9	25,0	-	-	SK 92772.1 - 100 L/4	SK 92772.1 - 100 LH/4	SK 92772.1 - 100 LP/4	60,0	B30-31					
	41	509	1,3	35,04	9,3	25,0	-	-										
	45	463	1,4	31,85	9,5	25,0	-	-										
	51	413	1,5	28,38	9,7	25,0	-	-										
	57	368	1,7	25,34	9,9	25,0	-	-										
	64	328	2,0	22,59	10,0	25,0	-	-										
	68	307	2,0	21,14	10,0	25,0	-	-										
	75	279	2,3	19,17	10,1	25,0	-	-										
	77	274	2,3	18,84	10,1	25,0	-	-										
	85	248	2,6	17,08	10,2	25,0	-	-										
	94	224	2,8	15,42	10,2	25,0	-	-										
	105	200	3,0	13,79	10,3	25,0	-	-										
	116	182	3,3	12,50	10,3	25,0	-	-										
															SK 93772.1 - 100 L/4	SK 93772.1 - 100 LH/4	SK 93772.1 - 100 LP/4	
	58	362	1,0	24,88	7,5	20,0	-	-	SK 92672.1 - 100 L/4	SK 92672.1 - 100 LH/4	SK 92672.1 - 100 LP/4	48,6	B28-29					
	79	265	1,3	18,21	8,0	20,0	-	-										
	83	254	1,2	17,46	8,0	20,0	-	-										
	93	226	1,6	15,56	8,1	20,0	-	-										
	100	209	1,5	14,40	8,2	20,0	-	-										
	113	187	1,9	12,84	8,2	20,0	-	-										
	127	166	2,2	11,39	8,3	20,0	-	-										
	142	148	2,5	10,16	8,3	20,0	-	-										
	154	137	2,6	9,39	8,3	20,0	-	-										
	173	121	2,9	8,33	8,4	20,0	-	-										
	194	108	3,2	7,44	8,4	19,5	-	-										
														SK 93672.1 - 100 L/4	SK 93672.1 - 100 LH/4	SK 93672.1 - 100 LP/4		B40-41
	115	183	1,0	12,56	6,2	15,0	-	-						SK 92372.1 - 100 L/4	SK 92372.1 - 100 LH/4	SK 92372.1 - 100 LP/4	37,7	B26-27
	129	163	1,3	11,20	6,3	15,0	-	-										
	141	149	1,2	10,22	6,3	15,0	-	-										
	159	132	1,6	9,11	6,4	15,0	-	-										
	176	119	1,7	8,19	6,4	14,9	-	-										
	206	102	2,0	7,01	6,5	14,5	-	-										
	217	97	2,1	6,67	6,5	14,2	-	-										
	248	85	2,2	5,83	6,5	13,7	-	-										
	282	75	2,5	5,13	6,5	12,9	-	-										
	336	63	3,0	4,31	6,6	12,0	-	-										
	389	54	3,3	3,72	6,6	11,3	-	-										
									SK 93372.1 - 100 L/4	SK 93372.1 - 100 LH/4	SK 93372.1 - 100 LP/4		B38-39					
3,00	36	790	0,8	39,32	7,3	25,0	-	-	SK 92772.1 - 100 LA/4	SK 92772.1 - 100 AH/4	SK 92772.1 - 100 AP/4	60,0	B30-31					
	41	704	0,9	35,04	8,0	25,0	-	-										
	45	640	1,0	31,85	8,5	25,0	-	-										
	50	571	1,1	28,38	8,9	25,0	-	-										
	56	509	1,2	25,34	9,3	25,0	-	-										
	63	454	1,4	22,59	9,5	25,0	-	-										
	67	425	1,5	21,14	9,6	25,0	-	-										
	74	385	1,6	19,17	9,8	25,0	-	-										
	76	379	1,7	18,84	9,8	25,0	-	-										
	83	343	1,9	17,08	9,9	25,0	-	-										
	92	310	2,0	15,42	10,0	25,0	-	-										
	103	277	2,2	13,79	10,1	25,0	-	-										
	114	251	2,4	12,50	10,2	25,0	-	-										
	126	227	2,5	11,28	10,2	25,0	-	-										
	145	197	2,9	9,81	10,3	25,0	-	-										
	161	178	3,1	8,85	10,3	25,0	-	-										
	198	144	3,8	7,18	10,4	24,4	-	-										
	278	103	4,9	5,12	10,4	20,9	-	-										
															SK 93772.1 - 100 LA/4	SK 93772.1 - 100 AH/4	SK 93772.1 - 100 AP/4	
	78	366	1,0	18,21	7,5	20,0	-	-	SK 92672.1 - 100 LA/4	SK 92672.1 - 100 AH/4	SK 92672.1 - 100 AP/4	48,6	B28-29					
	82	351	0,9	17,46	7,6	20,0	-	-										
	92	313	1,2	15,56	7,8	20,0	-	-										
	99	290	1,1	14,40	7,9	20,0	-	-										
	111	258	1,4	12,84	8,0	20,0	-	-										
	125	229	1,6	11,39	8,1	20,0	-	-										
	140	204	1,8	10,16	8,2	20,0	-	-										
	152	189	1,9	9,39	8,2	20,0	-	-										

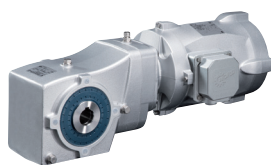
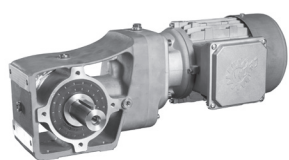

**3,00 kW**  
**4,00 kW**  
**5,50 kW**

P <sub>1</sub> [kW]	n <sub>2</sub> [min <sup>-1</sup> ]	M <sub>2</sub> [Nm]	f <sub>B</sub>	i <sub>ges</sub>	F <sub>R</sub> [kN]	F <sub>A</sub> [kN]	F <sub>R VL</sub> [kN]	F <sub>A VL</sub> [kN]	Gear unit motor			IE2 kg	mm mm				
									IE1	IE2	IE3						
3,00	171	168	2,1	8,33	8,3	19,5	-	-	SK 92672.1 - 100 LA/4	SK 92672.1 - 100 AH/4	SK 92672.1 - 100 AP/4	48,6	B28-29				
	192	149	2,3	7,44	8,3	19,0	-	-									
	213	134	2,4	6,68	8,3	18,6	-	-									
	253	113	2,7	5,64	8,4	17,1	-	-									
	327	88	3,6	4,36	8,4	15,3	-	-									
									SK 93672.1 - 100 LA/4	SK 93672.1 - 100 AH/4	SK 93672.1 - 100 AP/4				B40-41		
	127	225	1,0	11,20	5,9	14,9	-	-	SK 92372.1 - 100 LA/4	SK 92372.1 - 100 AH/4	SK 92372.1 - 100 AP/4			37,7	B26-27		
	139	206	0,9	10,22	5,9	14,4	-	-									
	156	183	1,2	9,11	6,2	14,4	-	-									
	174	165	1,3	8,19	6,3	14,0	-	-									
203	141	1,4	7,01	6,4	13,8	-	-										
214	134	1,5	6,67	6,4	13,5	-	-										
244	117	1,6	5,83	6,4	13,0	-	-										
278	103	1,8	5,13	6,5	12,3	-	-										
331	87	2,1	4,31	6,5	11,5	-	-										
383	75	2,4	3,72	6,5	10,9	-	-										
								SK 93372.1 - 100 LA/4	SK 93372.1 - 100 AH/4	SK 93372.1 - 100 AP/4		B38-39					
4,00	57	672	0,9	25,34	8,3	25,0	-	-	SK 92772.1 - 112 M/4	SK 92772.1 - 112 MH/4	SK 92772.1 - 112 MP/4	70,3	B30-31				
	64	599	1,1	22,59	8,8	25,0	-	-									
	68	561	1,1	21,14	9,0	25,0	-	-									
	75	508	1,2	19,17	9,3	25,0	-	-									
	76	500	1,3	18,84	9,3	25,0	-	-									
	84	453	1,4	17,08	9,5	25,0	-	-									
	93	409	1,5	15,42	9,7	25,0	-	-									
	104	366	1,7	13,79	9,9	25,0	-	-									
	115	332	1,8	12,50	10,0	25,0	-	-									
	128	299	1,9	11,28	10,1	25,0	-	-									
	147	260	2,2	9,81	10,2	25,0	-	-									
	163	235	2,4	8,85	10,2	24,9	-	-									
	201	190	2,9	7,18	10,3	23,3	-	-									
	281	136	3,7	5,12	10,4	20,2	-	-									
									SK 93772.1 - 112 M/4	SK 93772.1 - 112 MH/4	SK 93772.1 - 112 MP/4				B42-43		
	93	413	0,9	15,56	7,2	20,0	-	-	SK 92672.1 - 112 M/4	SK 92672.1 - 112 MH/4	SK 92672.1 - 112 MP/4			58,9	B28-29		
	100	382	0,8	14,40	7,4	20,0	-	-									
	112	341	1,1	12,84	7,6	20,0	-	-									
	126	302	1,2	11,39	7,8	19,7	-	-									
142	270	1,3	10,16	7,9	19,5	-	-										
153	249	1,4	9,39	8,0	19,0	-	-										
173	221	1,6	8,33	8,1	18,6	-	-										
194	197	1,8	7,44	8,2	18,1	-	-										
215	177	1,8	6,68	8,2	17,8	-	-										
255	150	2,1	5,64	8,3	16,3	-	-										
330	116	2,7	4,36	8,4	14,7	-	-										
								SK 93672.1 - 112 M/4	SK 93672.1 - 112 MH/4	SK 93672.1 - 112 MP/4		B40-41					
5,50	76	689	0,9	19,17	8,1	25,0	-	-	SK 92772.1 - 132 S/4	SK 92772.1 - 132 SH/4	SK 92772.1 - 132 SP/4	89,8	B30-31				
	85	615	1,0	17,08	8,7	25,0	-	-									
	95	555	1,1	15,42	9,0	25,0	-	-									
	117	450	1,3	12,50	9,5	24,8	-	-									
	129	406	1,4	11,28	9,7	24,4	-	-									
	149	353	1,6	9,81	9,9	24,1	-	-									
	165	318	1,7	8,85	10,0	23,4	-	-									
	203	258	2,1	7,18	10,2	21,8	-	-									
	229	230	2,1	6,39	10,2	21,0	-	-									
	285	184	2,7	5,12	10,3	19,1	-	-									
									SK 93772.1 - 132 S/4	SK 93772.1 - 132 SH/4	SK 93772.1 - 132 SP/4				B42-43		
	144	366	1,0	10,16	7,5	17,9	-	-	SK 92672.1 - 132 S/4	SK 92672.1 - 132 SH/4	SK 92672.1 - 132 SP/4			78,4	B28-29		
	175	300	1,2	8,33	7,8	17,2	-	-									
	196	267	1,3	7,44	8,0	16,9	-	-									
	218	240	1,3	6,68	8,1	16,5	-	-									
	259	203	1,5	5,64	8,2	15,2	-	-									
	335	157	2,0	4,36	8,2	13,9	-	-									
									SK 93672.1 - 132 S/4	SK 93672.1 - 132 SH/4	SK 93672.1 - 132 SP/4						B40-41

**7,50 kW**  
**9,20 kW**



P <sub>1</sub> [kW]	n <sub>2</sub> [min <sup>-1</sup> ]	M <sub>2</sub> [Nm]	f <sub>B</sub>	i <sub>ges</sub>	F <sub>R</sub> [kN]	F <sub>A</sub> [kN]	F <sub>R VL</sub> [kN]	F <sub>A VL</sub> [kN]	Gear unit motor			IE2 kg	mm H			
									IE1 Standard	IE2	IE3					
<b>7,50</b>	85	838	0,8	17,08	6,8	22,6	-	-	SK 92772.1 - 132 M/4	SK 92772.1 - 132 MH/4	SK 92772.1 - 132 MP/4	96,8	B30-31			
	95	756	0,8	15,42	7,6	22,6	-	-								
	117	613	1,0	12,50	8,7	22,1	-	-								
	129	553	1,0	11,28	9,0	22,0	-	-								
	149	481	1,2	9,81	9,4	22,1	-	-								
	165	434	1,3	8,85	9,6	21,4	-	-								
	203	352	1,6	7,18	9,9	20,0	-	-								
	229	313	1,6	6,39	10,0	19,5	-	-								
	285	251	2,0	5,12	10,2	18,0	-	-								
	350	204	2,4	4,17	10,3	16,8	-	-								
									SK 93772.1 - 132 M/4	SK 93772.1 - 132 MH/4	SK 93772.1 - 132 MP/4		B42-43			
	175	409	0,9	8,33	7,2	15,4	-	-	SK 92672.1 - 132 M/4	SK 92672.1 - 132 MH/4	SK 92672.1 - 132 MP/4	85,4	B28-29			
	196	365	1,0	7,44	7,5	15,0	-	-								
	218	328	1,0	6,68	7,7	15,0	-	-								
	259	277	1,1	5,64	7,9	13,9	-	-								
	335	214	1,5	4,36	7,7	12,9	-	-								
									SK 93672.1 - 132 M/4	SK 93672.1 - 132 MH/4	SK 93672.1 - 132 MP/4		B40-41			
<b>9,20</b>	148	594	1,0	9,81	8,8	20,4	-	-	SK 92772.1 - 132 MA/4			96,8	B30-31			
	164	536	1,0	8,85	9,1	19,5	-	-								
	202	435	1,3	7,18	9,6	18,6	-	-								
	227	387	1,3	6,39	9,8	18,3	-	-								
	283	310	1,6	5,12	10,0	17,0	-	-								
	348	252	2,0	4,17	9,9	16,0	-	-								
										SK 93772.1 - 132 MA/4						B42-43
		217	405	0,8	6,68	7,2	13,7	-	-	SK 92672.1 - 132 MA/4					85,4	B28-29
		257	342	0,9	5,64	7,3	12,8	-	-							
		333	264	1,2	4,36	7,2	12,0	-	-							
									SK 93672.1 - 132 MA/4				B40-41			



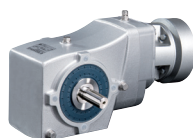
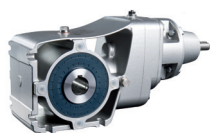

# SK 920072.1 SK 930072.1

	$i_{ges}$	$n_2$ $n_1 =$ $1400 \text{min}^{-1}$ [ $\text{min}^{-1}$ ]	$M_{2max}$ $f_B = 1$ [Nm]	W			IEC						
				$P_{1max}$		$f_B \geq 1$ $n_1 =$ $700 \text{min}^{-1}$ [kW]	$f_B \Rightarrow B2-12$						
				$n_1 =$ $1400 \text{min}^{-1}$ [kW]	$n_1 =$ $930 \text{min}^{-1}$ [kW]		56	63	71	80			
SK 920072.1	47,67	29	37,5	0,12	0,077	0,058		*	*	*			
SK 930072.1	41,56	34	37,5	0,13	0,088	0,066		*	*	*			
	36,67	38	37,5	0,15	0,1	0,075		*	*	*			
	31,57	44	37,5	0,17	0,12	0,087		*	*	*			
<b>W</b>	<b>27,52</b>	51	40	0,21	0,14	0,11			*	*			
	24,29	58	45	0,27	0,18	0,14			*	*			
$\frac{H}{mm}$	20,53	68	45	0,32	0,21	0,16			*	*			
$\Rightarrow B45, B51$	18,52	76	50	0,4	0,26	0,2				*			
	16,00	88	50	0,46	0,3	0,23				*			
	13,53	103	50	0,54	0,36	0,27				*			
	12,33	114	50	0,59	0,39	0,3				*			
	10,43	134	50	0,7	0,47	0,35				*			
<b>IEC</b>	<b>8,97</b>	156	50	0,75	0,54	0,41							
	7,58	185	50	0,75	0,64	0,48							
$\frac{H}{mm}$	6,67	210	50	0,75	0,73	0,55							
$\Rightarrow B46, B52$	6,40	219	50	0,75	0,75	0,57							
	5,64	248	45	0,75	0,75	0,59							
	5,17	271	37,5	0,75	0,71	0,53							
	4,50	311	40	0,75	0,75	0,65							
	3,97	352	40	0,75	0,75	0,74							
	3,36	417	40	0,75	0,75	0,75							
	3,03	463	40	0,75	0,75	0,75							

\*  $\Rightarrow A5$

# SK 92072.1 SK 93072.1

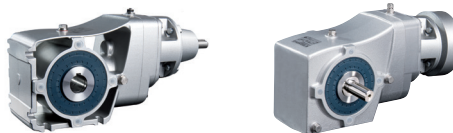

	$i_{ges}$	$n_2$ $n_1 =$ $1400 \text{min}^{-1}$ [ $\text{min}^{-1}$ ]	$M_{2max}$ $f_B = 1$ [Nm]	W			IEC							
				$P_{1max}$		$f_B \geq 1$ $n_1 =$ $700 \text{min}^{-1}$ [kW]	$f_B \Rightarrow$ B2-12							
				$n_1 =$ $1400 \text{min}^{-1}$ [kW]	$n_1 =$ $930 \text{min}^{-1}$ [kW]		56	63	71	80	90			
SK 92072.1	61,88	23	59	0,14	0,09	0,07		*	*	*				
SK 93072.1	53,78	26	52	0,14	0,09	0,07		*	*	*				
	47,67	29	46	0,14	0,09	0,07		*	*	*				
	40,98	34	59	0,21	0,14	0,11				*	*			
<b>W</b>	<b>35,62</b>	<b>39</b>	65	0,27	0,18	0,13				*	*			
	31,57	44	65	0,30	0,20	0,15				*	*			
$\frac{H}{mm}$	27,16	52	65	0,35	0,23	0,18				*	*			
$\Rightarrow$ B45, B51	24,07	58	79	0,48	0,32	0,24					*			
	20,80	67	81	0,57	0,38	0,29					*			
	18,52	76	60	0,47	0,32	0,24					*			
	16,00	88	66	0,60	0,40	0,30					*			
	12,78	110	59	0,68	0,45	0,34					*			
<b>IEC</b>	11,11	126	65	0,86	0,57	0,43								
	9,85	142	76	1,10	0,73	0,55								
$\frac{H}{mm}$	8,67	162	74	1,10	0,73	0,55								
$\Rightarrow$ B46, B52	7,58	185	72	1,10	0,73	0,55								
	6,67	210	68	1,10	0,73	0,55								
	5,83	240	72	1,10	0,73	0,55								
	5,17	271	67	1,10	0,73	0,55								
	4,65	301	65	1,10	0,73	0,55								
	3,97	353	68	1,10	0,73	0,55								
	3,58	391	66	1,10	0,73	0,55								

\*  $\Rightarrow$  A5

$\frac{H}{kg}$	W	IEC...
SK 92072.1	4	4
SK 93072.1	4	4

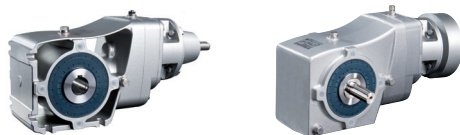

# SK 92172.1 SK 93172.1

	$i_{ges}$	$n_2$ $n_1 =$ $1400 \text{min}^{-1}$ [ $\text{min}^{-1}$ ]	$M_{2max}$ $f_B = 1$ [Nm]	W			IEC $f_B \Rightarrow$ B2-12								
				$P_{1max}$		$f_B \geq 1$ $n_1 =$ $700 \text{min}^{-1}$ [kW]	56	63	71	80	90				
				$n_1 =$ $1400 \text{min}^{-1}$ [kW]	$n_1 =$ $930 \text{min}^{-1}$ [kW]										
SK 92172.1	70,00	20	73	0,15	0,10	0,08		*							
SK 93172.1	63,78	22	67	0,15	0,10	0,08		*							
	56,00	25	59	0,15	0,10	0,08		*							
	46,43	30	93	0,29	0,20	0,15			*						
W	42,30	33	103	0,36	0,24	0,18			*						
	38,75	36	93	0,35	0,23	0,18			*						
$\frac{H}{mm}$	37,14	38	90	0,36	0,24	0,18			*						
$\Rightarrow$ B45, B51	35,31	40	108	0,45	0,30	0,22									
	31,00	45	108	0,51	0,34	0,26									
	28,24	50	108	0,56	0,37	0,28				*					
	24,80	56	120	0,71	0,47	0,35				*					
	20,67	68	104	0,74	0,49	0,37				*					
IEC	15,23	92	93	0,90	0,59	0,45									
	13,87	101	108	1,14	0,76	0,57									
$\frac{H}{mm}$	12,34	114	108	1,28	0,85	0,64									
$\Rightarrow$ B47, B53	12,18	115	114	1,37	0,91	0,69									
	10,83	129	113	1,50	1,00	0,75									
	10,15	138	95	1,37	0,91	0,69									
	9,49	148	107	1,50	1,00	0,75									
	9,03	155	94	1,50	1,00	0,75									
	8,33	168	115	1,50	1,00	0,75									
	7,83	179	111	1,50	1,00	0,75									
	6,94	202	110	1,50	1,00	0,75									
	6,53	214	93	1,50	1,00	0,75									
	5,77	243	92	1,50	1,00	0,75									
	5,26	266	107	1,50	1,00	0,75									
	4,89	286	107	1,50	1,00	0,75									
	4,30	326	106	1,50	1,00	0,75									
	3,85	364	89	1,50	1,00	0,75									
	3,58	391	88	1,50	1,00	0,75									

\*  $\Rightarrow$  A5

kg	W	IEC...
SK 92172.1	7	7
SK 93172.1	7	7

# SK 92372.1 SK 93372.1

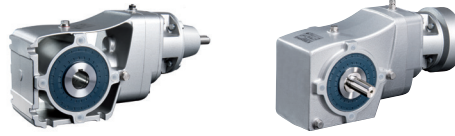

	$i_{ges}$	$n_2$ $n_1 =$ $1400 \text{min}^{-1}$ [ $\text{min}^{-1}$ ]	$M_{2max}$ $f_B = 1$ [Nm]	W			IEC								
				$P_{1max}$		$f_B \geq 1$ $n_1 =$ $700 \text{min}^{-1}$ [kW]	$f_B \Rightarrow B2-12$								
				$n_1 =$ $1400 \text{min}^{-1}$ [kW]	$n_1 =$ $930 \text{min}^{-1}$ [kW]		63	71	80	90	100	112	132		
SK 92372.1	55,49	25	158	0,42	0,28	0,21			*	*					
SK 93372.1	49,46	28	141	0,42	0,28	0,21			*	*					
	46,64	30	184	0,58	0,38	0,29			*	*					
	41,46	34	184	0,65	0,43	0,33			*	*					
W	36,80	38	184	0,73	0,49	0,37			*	*					
	32,80	43	198	0,89	0,59	0,44				*					
$\frac{H}{mm}$	28,11	50	184	0,96	0,64	0,48				*					
$\Rightarrow B45, B51$	25,06	56	219	1,28	0,85	0,64				*					
	22,49	62	184	1,20	0,80	0,60				*					
	20,04	70	219	1,60	1,06	0,80									
	18,33	76	183	1,46	0,97	0,73				*					
	15,84	88	184	1,70	1,13	0,85									
IEC	14,12	99	218	2,26	1,50	1,13									
	12,56	112	184	2,15	1,43	1,07					*				
$\frac{H}{mm}$	11,20	125	218	2,85	1,90	1,43					*				
$\Rightarrow B48, B54$	10,33	136	220	3,00	1,99	1,50									
	10,22	137	184	2,64	1,75	1,32									
	9,11	154	218	3,00	1,99	1,50									
	8,19	171	208	3,00	1,99	1,50									
	7,01	200	201	3,00	1,99	1,50									
	6,67	210	205	3,00	1,99	1,50									
	5,83	240	189	3,00	1,99	1,50									
	5,13	273	185	3,00	1,99	1,50									
	4,31	325	186	3,00	1,99	1,50									
	3,72	376	181	3,00	1,99	1,50									

\*  $\Rightarrow A5$

$\frac{m}{kg}$	W	IEC 63	IEC 71	IEC 80	IEC 90	IEC 100	IEC 112
SK 92372.1	11	10	10	10	10	11	11
SK 93372.1	11	10	10	10	10	11	11

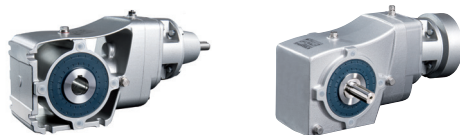

# SK 92672.1 SK 93672.1

	$i_{ges}$	$n_2$ $n_1 =$ $1400 \text{min}^{-1}$ [ $\text{min}^{-1}$ ]	$M_{2max}$ $f_B = 1$ [Nm]	W			IEC $f_B \Rightarrow$ B2-12								
				$P_{1max}$		$f_B \geq 1$ $n_1 =$ $700 \text{min}^{-1}$ [kW]	63	71	80	90	100	112	132		
				$n_1 =$ $1400 \text{min}^{-1}$ [kW]	$n_1 =$ $930 \text{min}^{-1}$ [kW]										
SK 92672.1	48,56	29	318	0,96	0,64	0,48				*					
SK 93672.1	43,28	32	306	1,04	0,69	0,52				*					
	37,82	37	318	1,23	0,82	0,62				*					
	33,71	42	363	1,58	1,05	0,79									
<b>W</b>	30,67	46	318	1,52	1,01	0,76									
	27,33	51	364	1,95	1,30	0,98									
$\frac{H}{mm}$	24,88	56	363	2,14	1,42	1,07				*		*			
	20,00	70	311	2,28	1,51	1,14									
$\Rightarrow$ B45, B51	18,21	77	349	2,81	1,87	1,40				*		*			
	17,46	80	317	2,66	1,77	1,33				*		*			
	15,56	90	363	3,42	2,27	1,71						*			
	14,40	97	317	3,23	2,14	1,61						*			
<b>IEC</b>	12,84	109	363	4,14	2,75	2,07									
	11,39	123	361	4,65	3,09	2,32									
$\frac{H}{mm}$	10,16	138	363	5,24	3,48	2,62									
$\Rightarrow$ B49, B55	9,39	149	355	5,54	3,68	2,77									
	8,33	168	350	6,16	4,09	3,08									
	7,44	188	349	6,88	4,57	3,44									
	6,68	210	317	6,96	4,62	3,48								*	
	5,64	248	310	8,06	5,35	4,03								*	
	4,36	321	315	9,20	6,11	4,60									

\*  $\Rightarrow$  A5

$\frac{m}{kg}$	W	IEC 63	IEC 71	IEC 80	IEC 90	IEC 100	IEC 112	IEC 132
SK 92672.1	24	23	23	23	23	24	24	26
SK 93672.1	24	23	23	23	23	24	24	26

# SK 92772.1 SK 93772.1

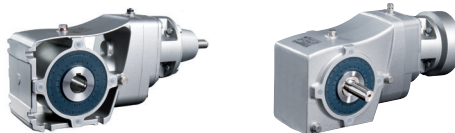

	$i_{ges}$	$n_2$ $n_1 =$ $1400 \text{min}^{-1}$ [ $\text{min}^{-1}$ ]	$M_{2max}$ $f_B = 1$ [Nm]	W			IEC										
				$P_{1max}$		$f_B \geq 1$ $n_1 =$ $700 \text{min}^{-1}$ [kW]	$f_B \Rightarrow \text{B2-12}$										
				$n_1 =$ $1400 \text{min}^{-1}$ [kW]	$n_1 =$ $930 \text{min}^{-1}$ [kW]		63	71	80	90	100	112	132				
SK 92772.1	66,96	21	489	1,07	0,71	0,54				*							
SK 93772.1	59,68	23	436	1,07	0,71	0,54				*							
	52,64	27	578	1,61	1,07	0,80											
	46,92	30	515	1,61	1,07	0,80											
<b>W</b>	43,44	32	630	2,13	1,41	1,06											
	39,32	36	630	2,35	1,56	1,17					*	*					
$\frac{H}{mm}$	35,04	40	660	2,76	1,83	1,38					*	*					
$\Rightarrow \text{B45, B51}$	31,85	44	630	2,90	1,93	1,45					*	*	*				*
	28,38	49	605	3,13	2,08	1,56							*	*			*
	27,65	51	630	3,34	2,22	1,67											
	25,34	55	630	3,64	2,42	1,82								*			*
	24,64	57	655	3,90	2,59	1,95											
<b>IEC</b>	22,59	62	650	4,22	2,80	2,11											*
	21,14	66	630	4,37	2,90	2,18											*
$\frac{H}{mm}$	19,17	73	630	4,82	3,20	2,41											*
$\Rightarrow \text{B50, B56}$	18,84	74	640	4,98	3,31	2,49											*
	17,08	82	645	5,54	3,68	2,77											*
	15,42	91	631	6,00	3,99	3,00											*
	13,79	102	605	6,43	4,27	3,22											*
	12,50	112	596	6,99	4,64	3,50											*
	11,28	124	575	7,47	4,96	3,74											*
	9,81	143	579	8,65	5,75	4,33											*
	8,85	158	555	9,19	6,11	4,60											*
	7,18	195	546	9,20	6,11	4,60											
	6,39	219	493	9,20	6,11	4,60											
	5,12	273	505	9,20	6,11	4,60											
	4,17	336	496	9,20	6,11	4,60											

\*  $\Rightarrow \text{A5}$

$\frac{kg}{kg}$	W	IEC 63	IEC 71	IEC 80	IEC 90	IEC 100	IEC 112	IEC 132
SK 92772.1	42	40	40	44	44	48	48	57
SK 93772.1	42	40	40	44	44	48	48	57







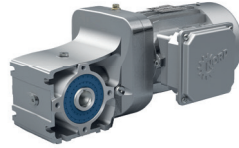

# SK 920072.1

## SK 920072.1 AB

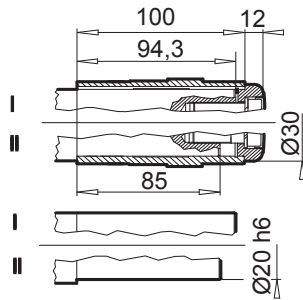

## SK 920072.1 AD

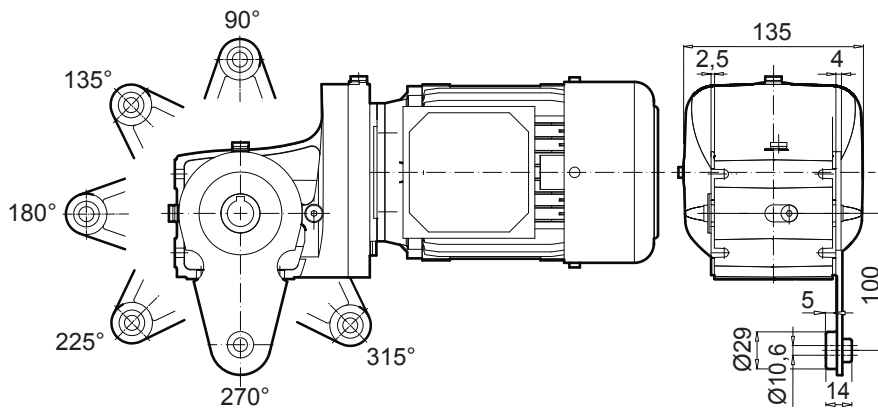

# SK 92072.1

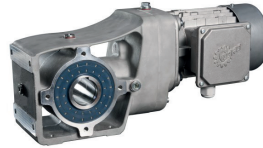

## SK 92072.1 V

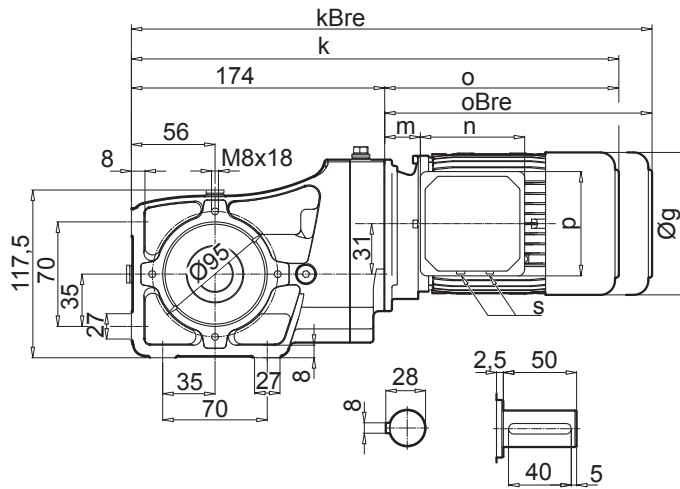

## SK 92072.1 A

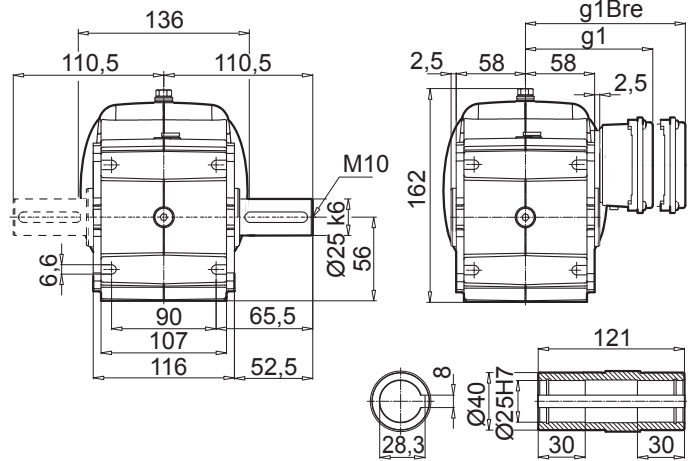

## SK 92072.1 VF

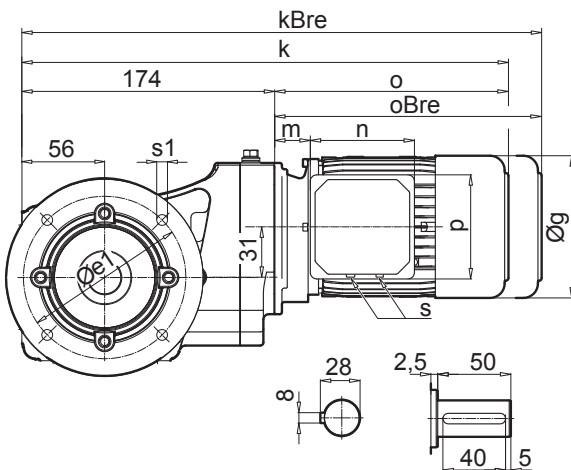

## SK 92072.1 AF

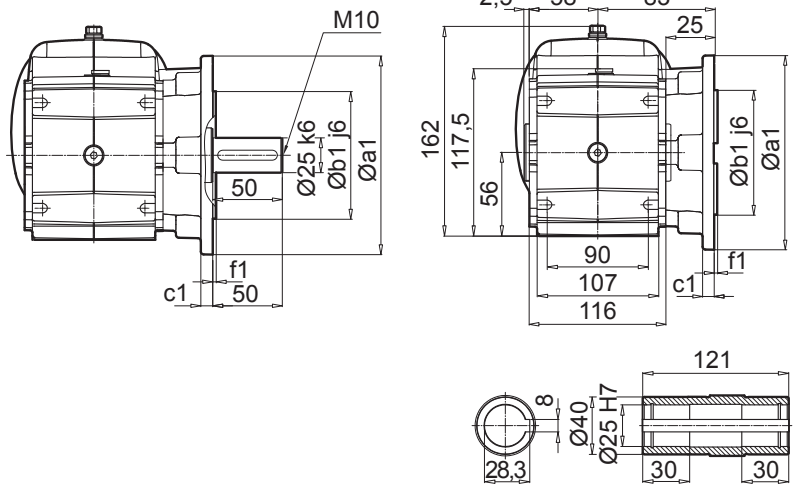

a1	b1	c1	e1	f1	s1
140	95	10	115	3,0	9

IE1 IE2 IE3	63 S / L - SP / LP	71 S / L - SP / LP	80 S / L SH / LH - / LP	90 S SH SP			
<b>g</b>	130	145	165	183			
<b>g1 / g1Bre</b>	115 / 123	124 / 132	142 / 142	147 / 147			
<b>k / kBre</b>	366 / 422	388 / 446	410 / 474	450 / 525			
<b>o / oBre</b>	192 / 248	214 / 272	236 / 300	276 / 351			
<b>m / mBre</b>	12 / 19	20 / 27	22 / 26	26 / 30			
<b>n / nBre</b>	100 / 134	100 / 134	114 / 153	114 / 153			
<b>p / pBre</b>	100 / 89	100 / 89	114 / 108	114 / 108			
<b>s</b>	M20 x 1,5	M20 x 1,5	M25 x 1,5	M25 x 1,5			
							W ⇔ B45
							IEC ⇔ B46



# SK 92172.1



## SK 92172.1 V

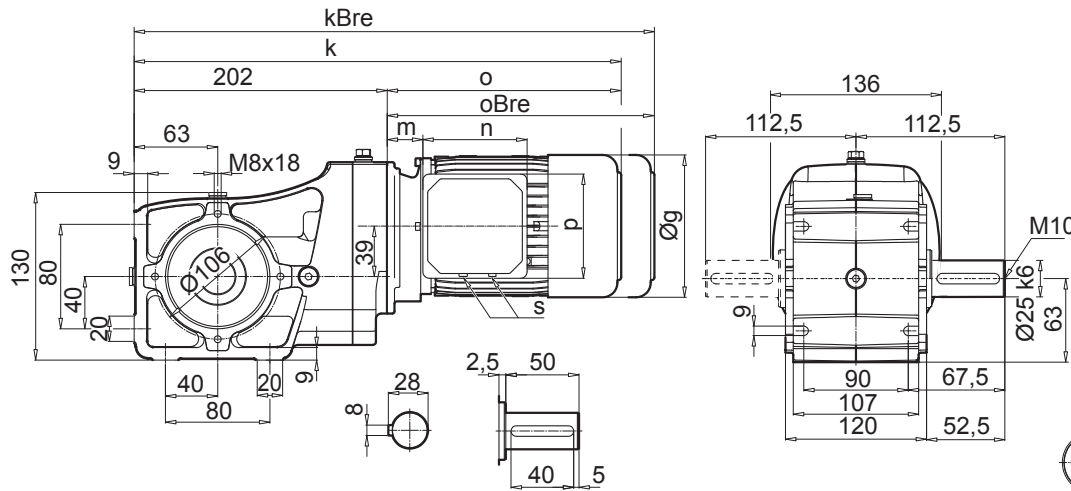

## SK 92172.1 A

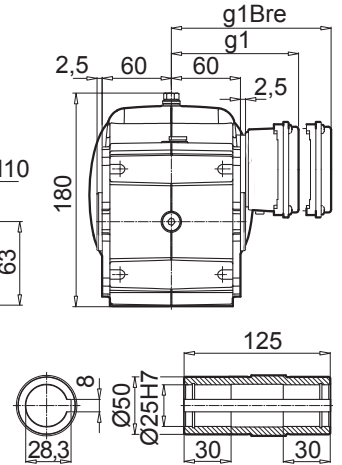

## SK 92172.1 VF

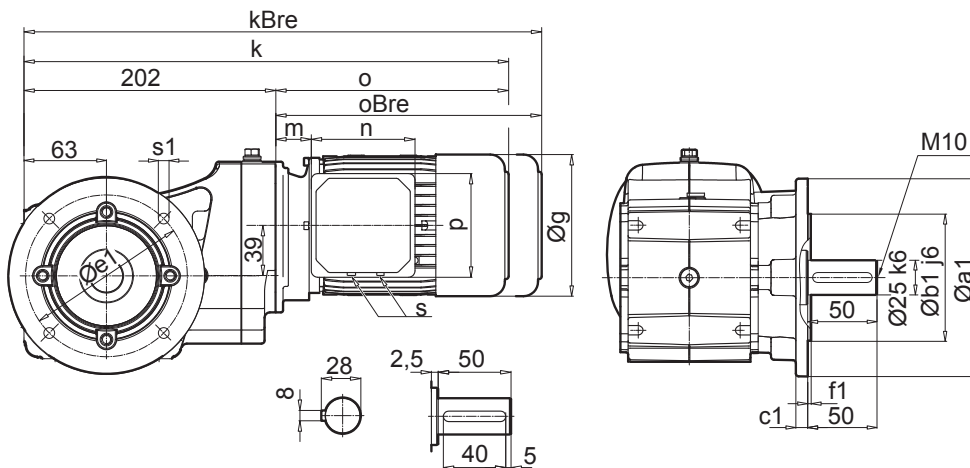

## SK 92172.1 AF

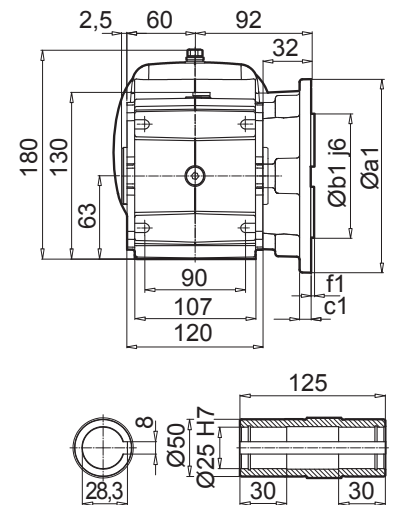

a1	b1	c1	e1	f1	s1
160	110	12	130	3,5	9

IE1 IE2 IE3	63 S / L - SP / LP	71 S / L - SP / LP	80 S / L SH / LH - / LP	90 S / L SH / LH SP / LP			
<b>g</b>	130	145	165	183			
<b>g1 / g1Bre</b>	115 / 123	124 / 132	142 / 142	147 / 147			
<b>k / kBre</b>	394 / 450	416 / 474	438 / 502	478 / 553			
<b>o / oBre</b>	192 / 248	214 / 272	236 / 300	276 / 351			
<b>m / mBre</b>	12 / 19	20 / 27	22 / 26	26 / 30			
<b>n / nBre</b>	100 / 134	100 / 134	114 / 153	114 / 153			
<b>p / pBre</b>	100 / 89	100 / 89	114 / 108	114 / 108			
<b>s</b>	M20 x 1,5	M20 x 1,5	M25 x 1,5	M25 x 1,5			



W ⇒ B45



IEC ⇒ B47



# SK 92372.1



## SK 92372.1 V

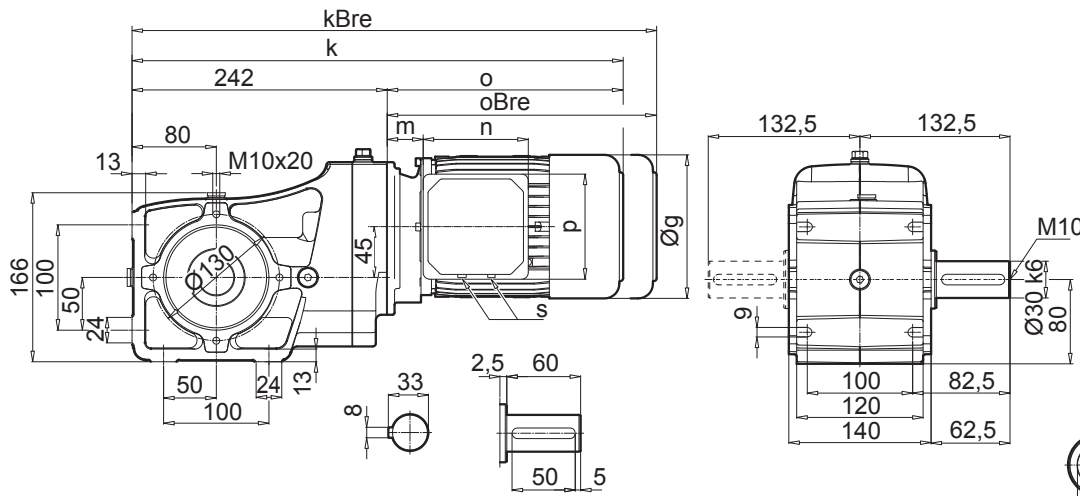

## SK 92372.1 A

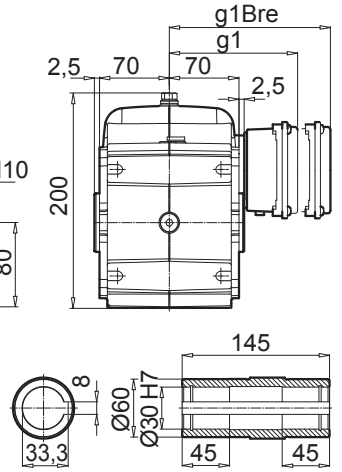

## SK 92372.1 VF

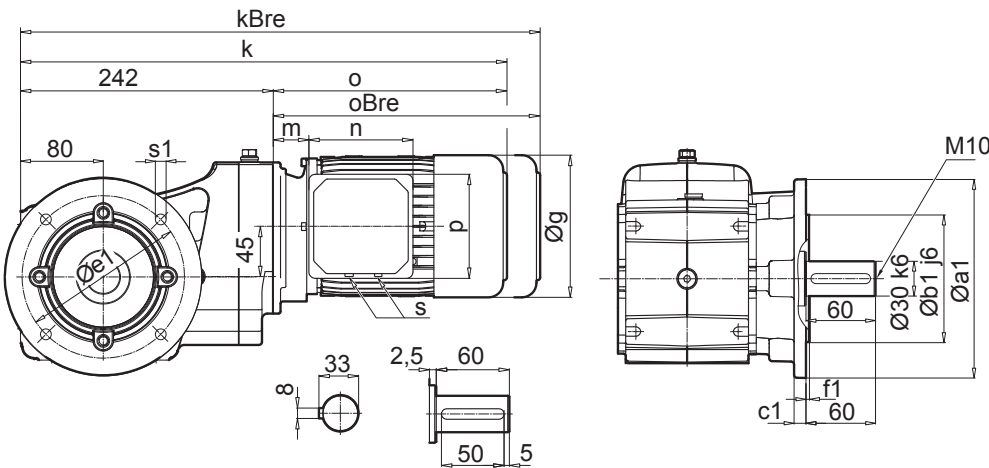

## SK 92372.1 AF

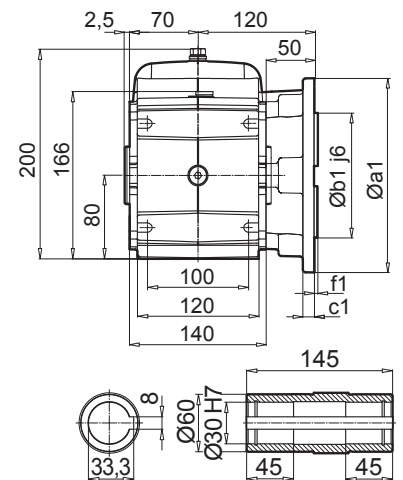

a1	b1	c1	e1	f1	s1
160	110	12	130	3,5	9
200	130	12	165	3,5	11

IE1 IE2 IE3	63 S / L - SP / LP	71 S / L - SP / LP	80 S / L SH / LH - / LP	90 S / L SH / LH SP / LP	100 L / LA LH / AH LP / AP		
g	130	145	165	183	201		
g1 / g1Bre	115 / 123	124 / 132	142 / 142	147 / 147	169 / 173		
k / kBre	438 / 494	478 / 536	503 / 567	544 / 619	574 / 665		
o / oBre	196 / 252	236 / 294	261 / 325	302 / 377	332 / 423		
m / mBre	16 / 23	42 / 49	47 / 51	52 / 56	58 / 62		
n / nBre	100 / 134	100 / 134	114 / 153	114 / 153	114 / 153		
p / pBre	100 / 89	100 / 89	144 / 108	144 / 108	144 / 108		
s	M20 x 1,5	M20 x 1,5	M25 x 1,5	M25 x 1,5	M25 x 1,5		

W ⇒ B45

IEC ⇒ B48

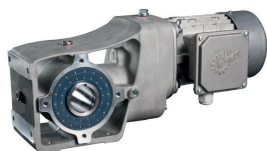

SK 92372.1 AB

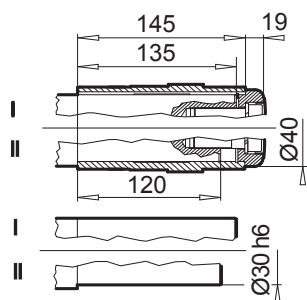

SK 92372.1 ASH

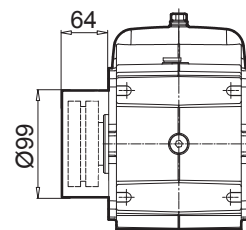
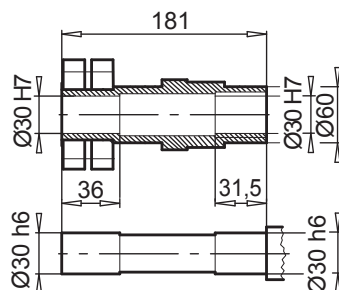

SK 92372.1 AD

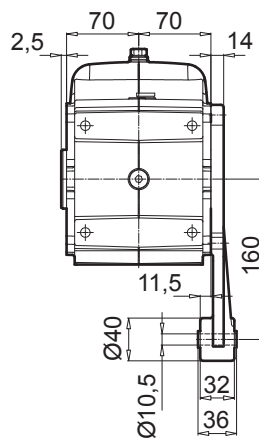
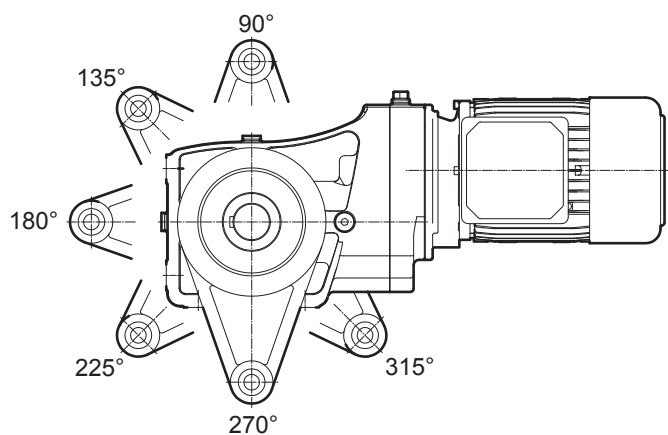

# SK 92672.1



## SK 92672.1 V

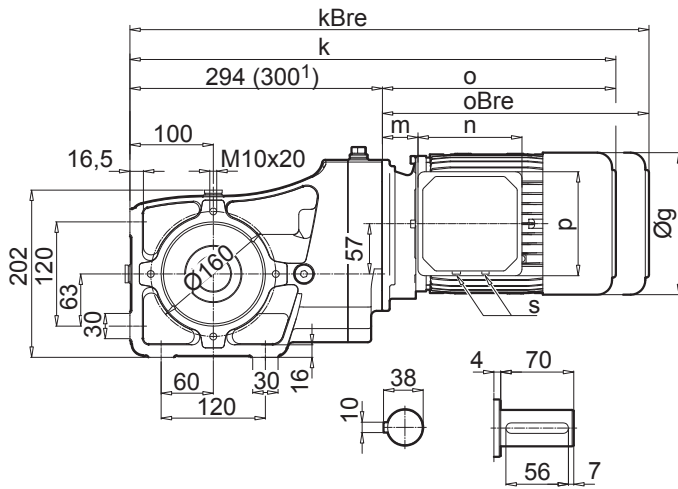

## SK 92672.1 A

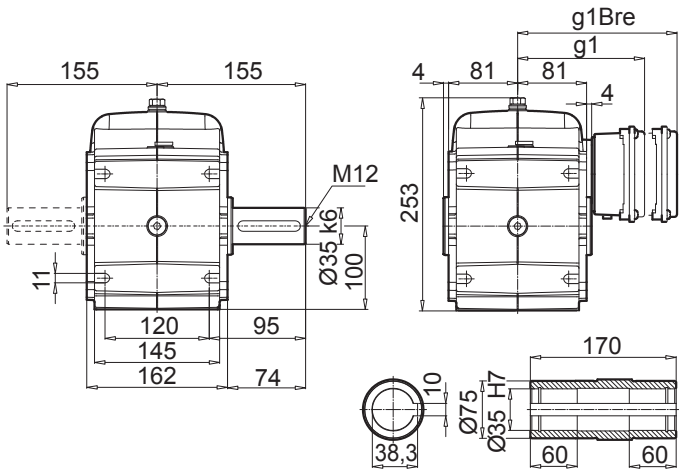

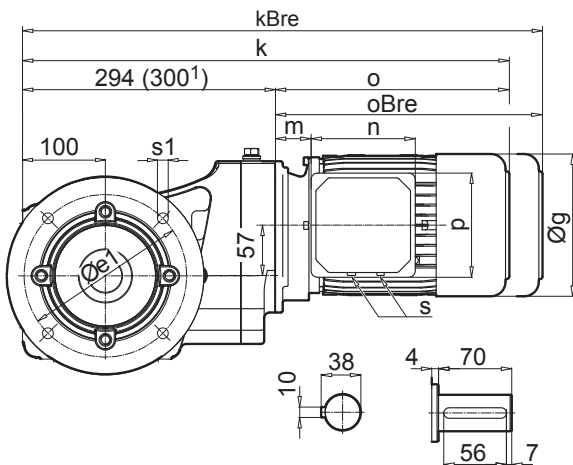

## SK 92672.1 VF

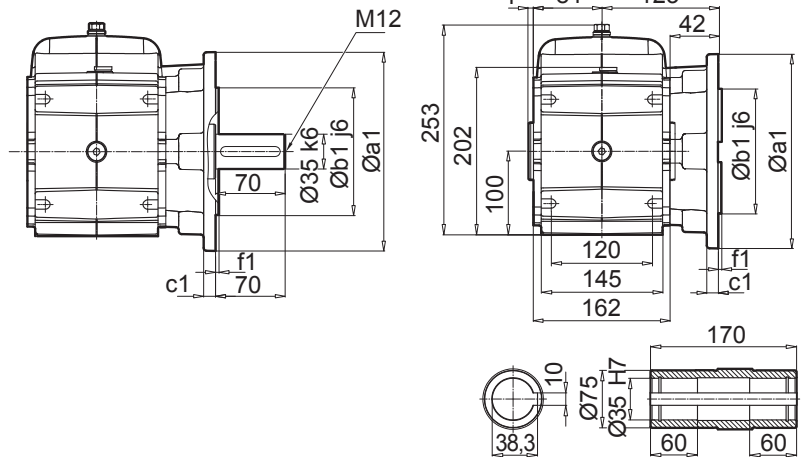

## SK 92672.1 AF



a1	b1	c1	e1	f1	s1
160	110	10	130	3,5	9
200	130	12	165	3,5	11,4

IE1 IE2 IE3	71 S / L - SP / LP	80 S / L SH / LH - / LP	90 S / L SH / LH SP / LP	100 L / LA LH / AH LP / AP	112 M - -	112 - MH MP	<sup>1)</sup> 132 S / M / MA SH / MH / - SP / MP / -	
g	145	165	183	201	228	228	266	
g1 / g1Bre	124 / 132	142 / 142	147 / 147	169 / 173	179 / 182	179 / 182	204 / 201	 W ⇨ B45
k / kBre	530 / 588	555 / 619	596 / 671	626 / 717	649 / 742	674 / 767	735 / 842	
o / oBre	236 / 294	261 / 325	302 / 377	332 / 423	355 / 448	380 / 473	435 / 542	
m / mBre	42 / 49	47 / 51	52 / 56	58 / 62	64 / 67	64 / 67	71 / 62	
n / nBre	100 / 134	114 / 153	114 / 153	114 / 153	114 / 153	114 / 153	122 / 185	
p / pBre	100 / 89	114 / 108	114 / 108	114 / 108	114 / 108	114 / 108	122 / 139	
s	M20 x 1,5	M25 x 1,5	M25 x 1,5	M25 x 1,5	M25 x 1,5	M25 x 1,5	M25 x 1,5	 IEC ⇨ B49



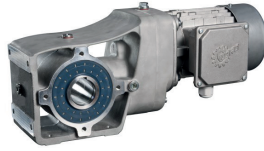

SK 92672.1 AB

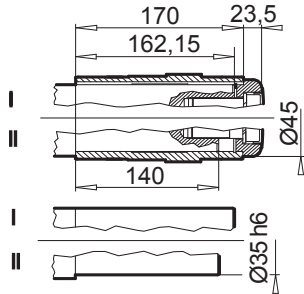

SK 92672.1 ASH

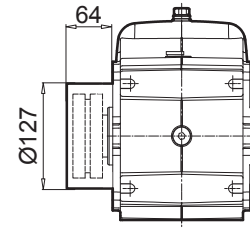
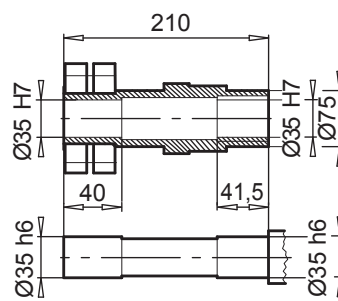

SK 92672.1 AD

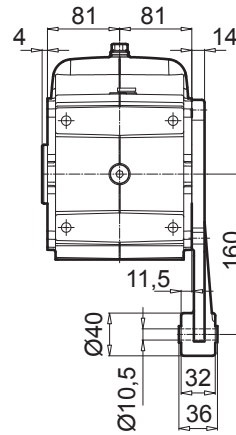
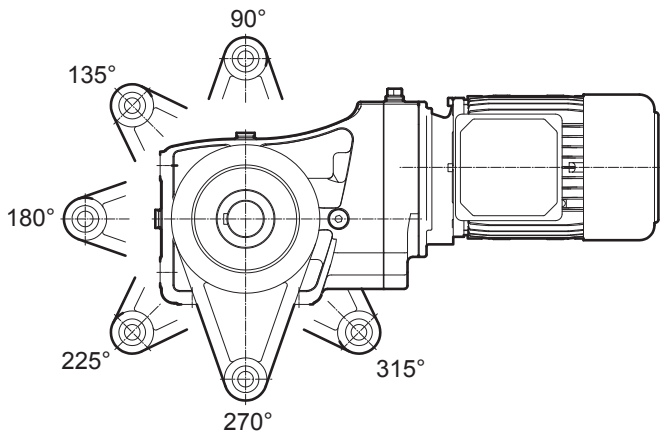

# SK 92772.1

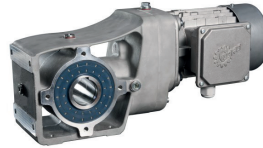

## SK 92772.1 V

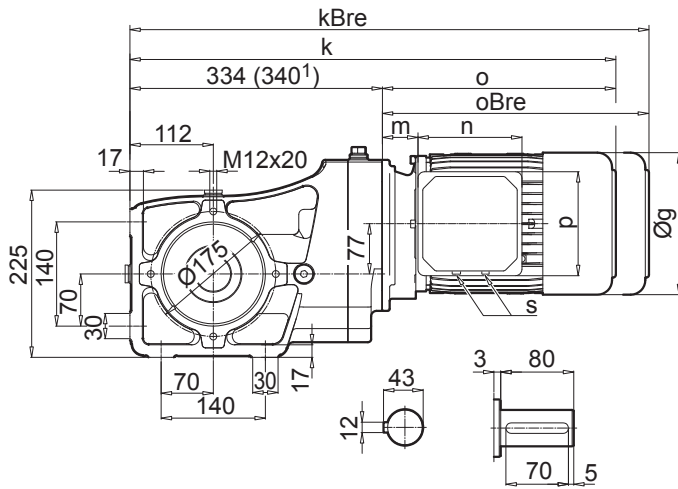

## SK 92772.1 A

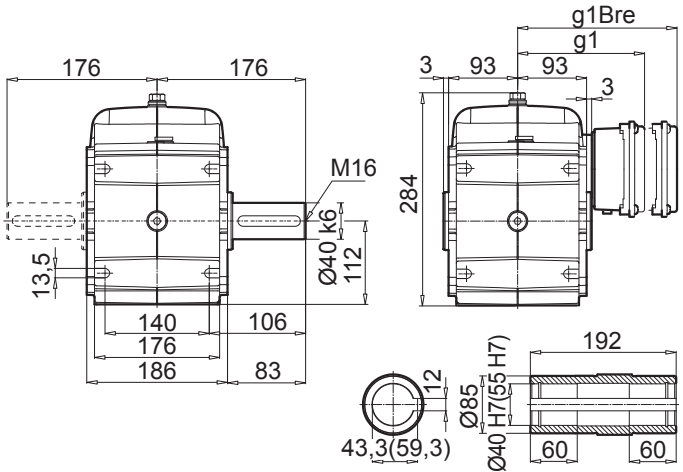

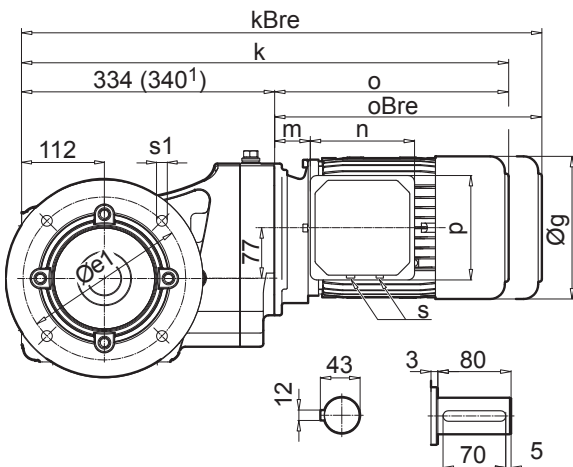

## SK 92772.1 VF

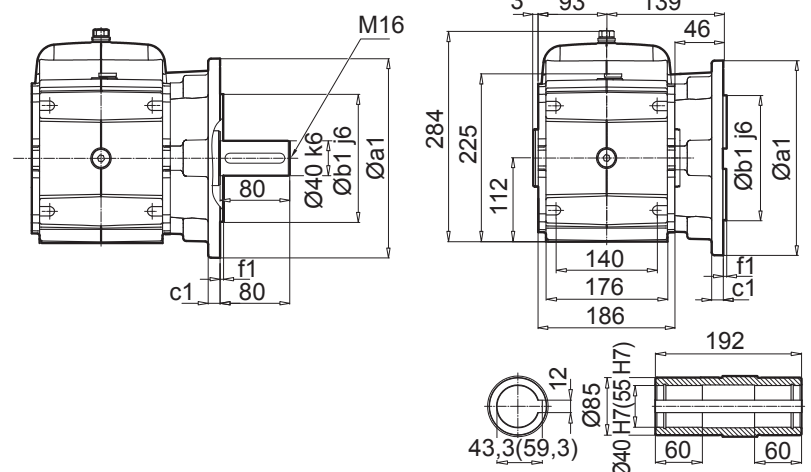

## SK 92772.1 AF



a1	b1	c1	e1	f1	s1
250	180	15	215	4	13,5

IE1 IE2 IE3	71 S / L - SP / LP	80 S / L SH / LH - / LP	90 S / L SH / LH SP / LP	100 L / LA LH / AH LP / AP	112 M - -	112 - MH MP	<sup>1)</sup> 132 S / M / MA SH / MH / - SP / MP / -	
g	145	165	183	201	228	228	266	
g1 / g1Bre	124 / 132	142 / 142	147 / 147	169 / 173	179 / 182	179 / 182	204 / 201	 W ⇨ B45
k / kBre	570 / 628	595 / 659	636 / 711	666 / 757	689 / 782	714 / 807	775 / 882	
o / oBre	236 / 294	261 / 325	302 / 377	332 / 423	355 / 448	380 / 473	435 / 542	
m / mBre	42 / 49	47 / 51	52 / 56	58 / 62	64 / 67	64 / 67	71 / 62	
n / nBre	100 / 134	114 / 153	114 / 153	114 / 153	114 / 153	114 / 153	122 / 185	
p / pBre	100 / 89	114 / 108	114 / 108	114 / 108	114 / 108	114 / 108	122 / 139	
s	M20 x 1,5	M25 x 1,5	M25 x 1,5	M25 x 1,5	M25 x 1,5	M25 x 1,5	M25 x 1,5	 IEC ⇨ B50

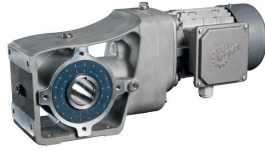

SK 92772.1 AB

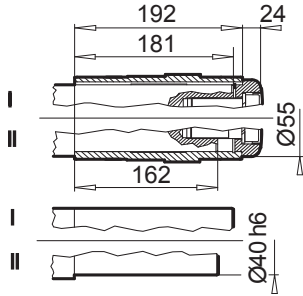

SK 92772.1 ASH

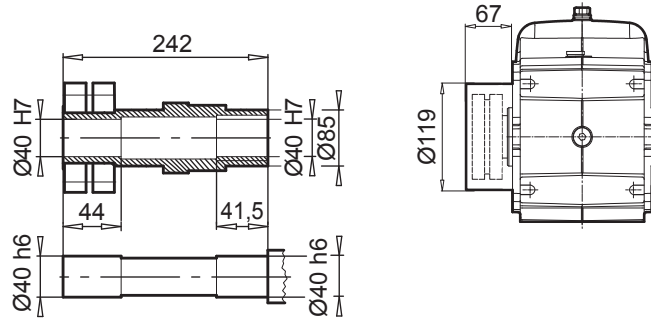

SK 92772.1 AD

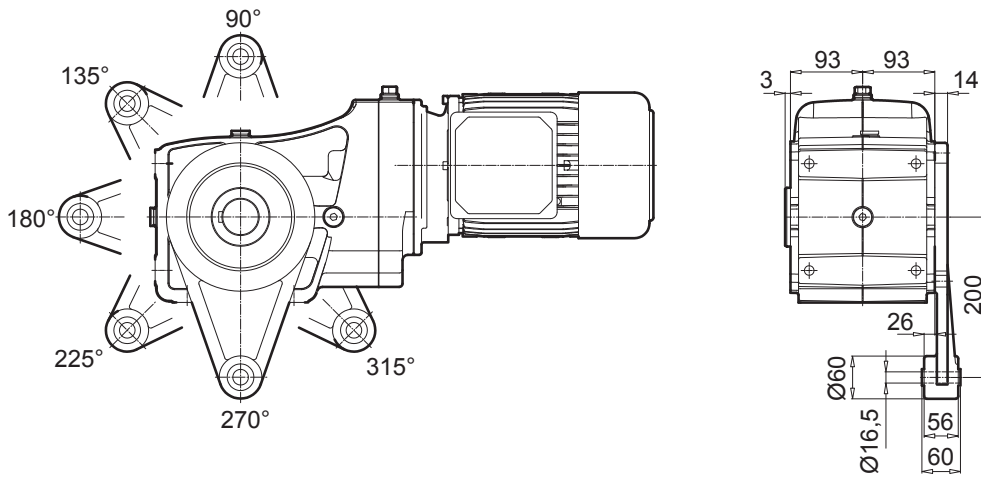

# SK 930072.1

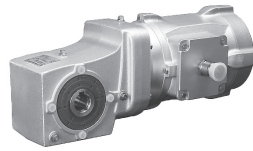

## SK 930072.1 V

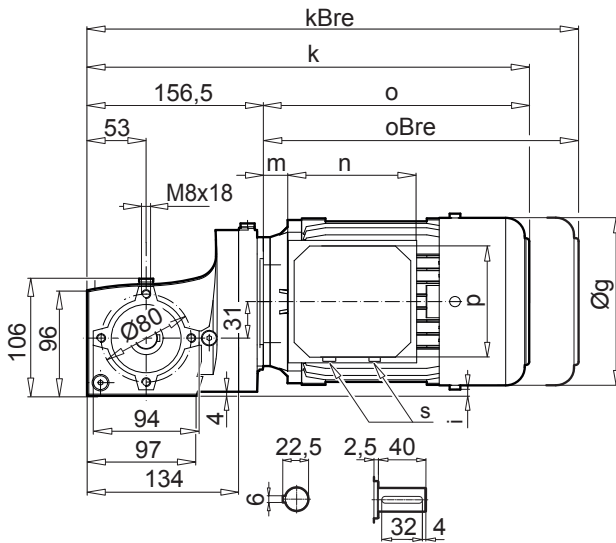

## SK 930072.1 A

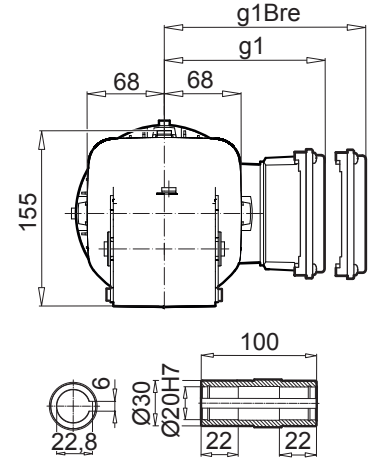

## SK 930072.1 VF

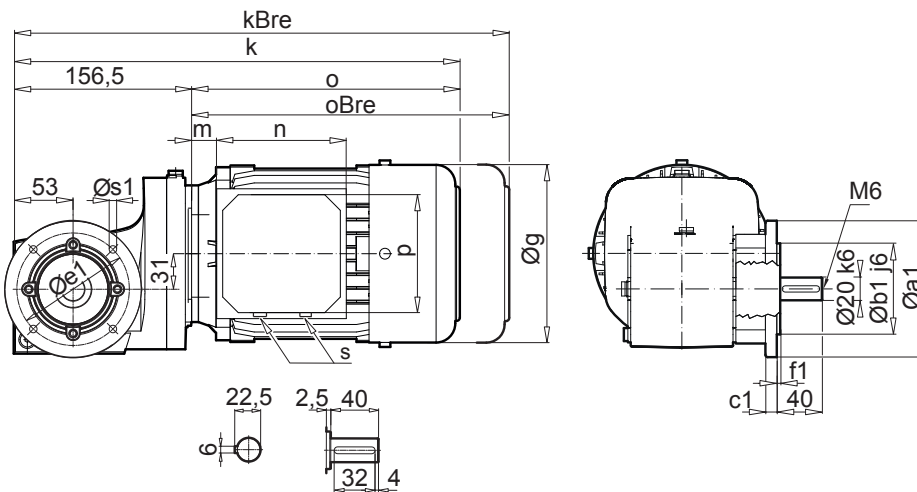

## SK 930072.1 AF

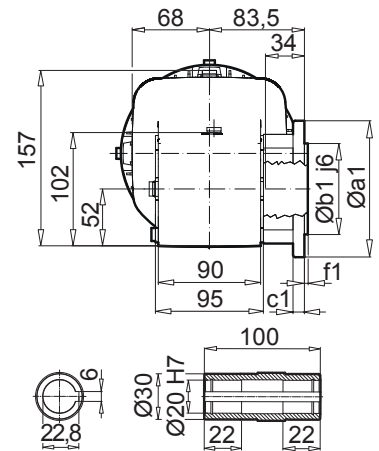

a1	b1	c1	e1	f1	s1
110	75	7	95	4,0	4 x 9
120	80	10	100	3,0	4 x 7
140	95	10	115	3,0	4 x 9

IE1 IE2 IE3	63 S / L - SP / LP	71 S / L - SP / LP	80 S / L SH / LH - / LP				
g	130	145	165				
g1 / g1Bre	115 / 123	124 / 132	142 / 142				
k / kBre	349 / 405	371 / 429	393 / 457				
o / oBre	192 / 248	214 / 272	236 / 300				
m / mBre	12 / 18	20 / 26	22 / 26				
n / nBre	100 / 134	100 / 134	114 / 153				
p / pBre	100 / 89	100 / 89	114 / 108				
i	16	8	-2				
s	M20 x 1,5	M20 x 1,5	M25 x 1,5				



W ⇨ B51



IEC ⇨ B52

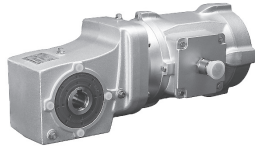

**SK 930072.1 AB**

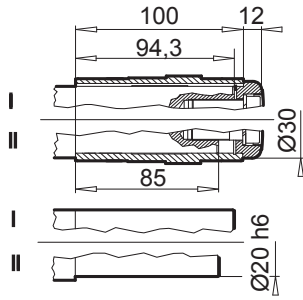

**SK 930072.1 AD**

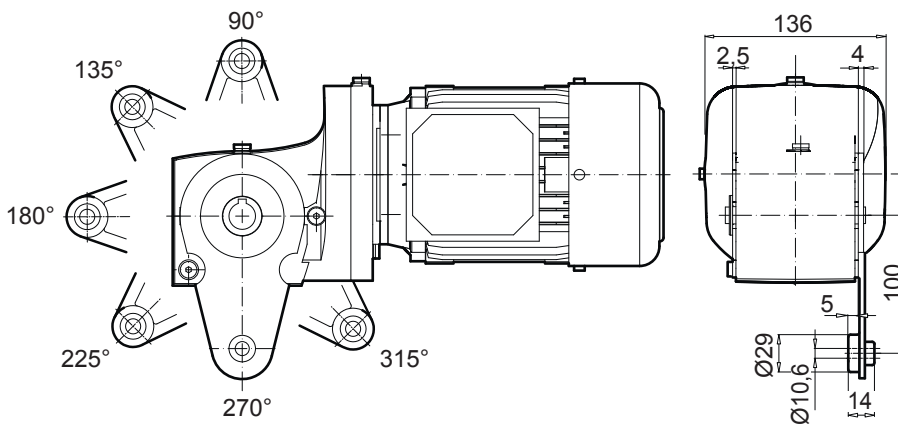

# SK 93072.1

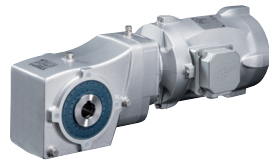

## SK 93072.1 V

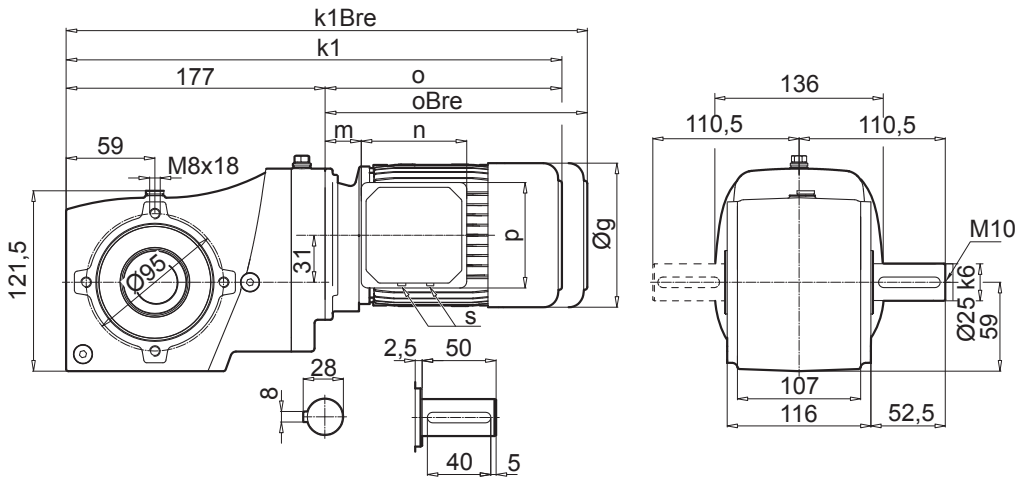

## SK 93072.1 A

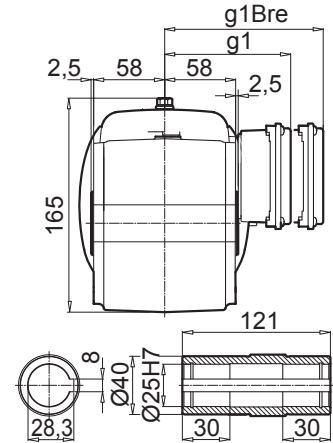

## SK 93072.1 VF

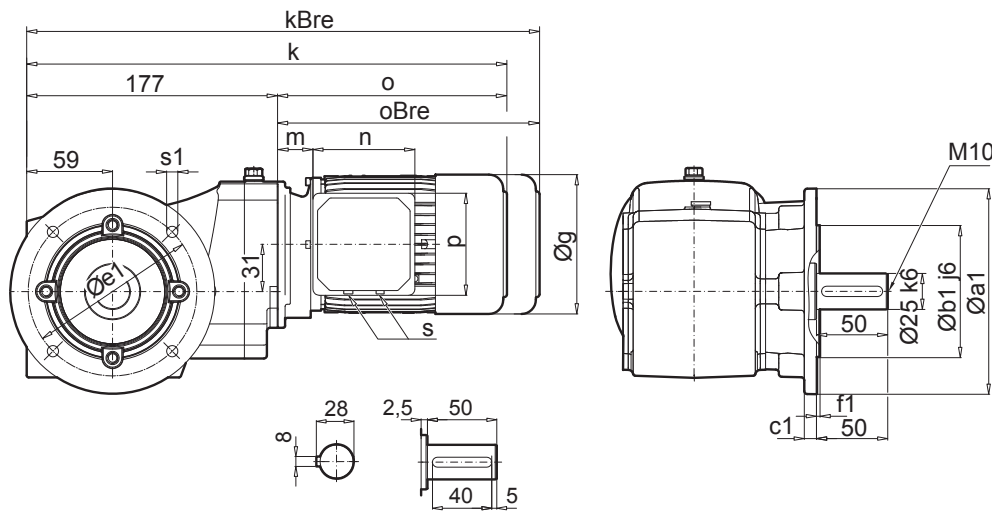

## SK 93072.1 AF

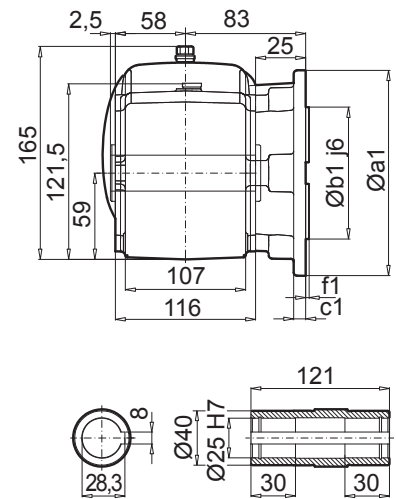

a1	b1	c1	e1	f1	s1
140	95	10	115	3,0	9

IE1 IE2 IE3	63 S / L - SP / LP	71 S / L - SP / LP	80 S / L SH / LH - / LP	90 S SH SP			
<b>g</b>	130	145	165	183			
<b>g1 / g1Bre</b>	115 / 123	124 / 132	142 / 142	147 / 147			
<b>k1 / k1Bre</b>	369 / 425	391 / 449	413 / 477	453 / 528			
<b>o / oBre</b>	192 / 248	214 / 272	236 / 300	276 / 351			
<b>m / mBre</b>	12 / 19	20 / 27	22 / 26	26 / 30			
<b>n / nBre</b>	100 / 134	100 / 134	114 / 153	114 / 153			
<b>p / pBre</b>	100 / 89	100 / 89	114 / 108	114 / 108			
<b>s</b>	M20 x 1,5	M20 x 1,5	M25 x 1,5	M25 x 1,5			



W ⇨ B51



IEC ⇨ B52



SK 93072.1 AB

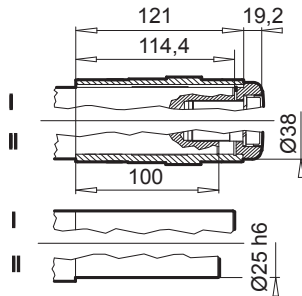

SK 93072.1 ASH

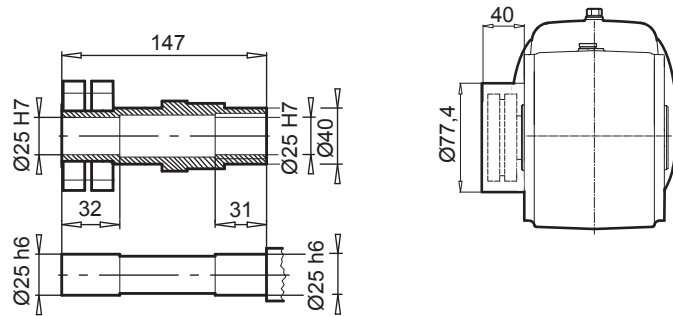

SK 93072.1 AD

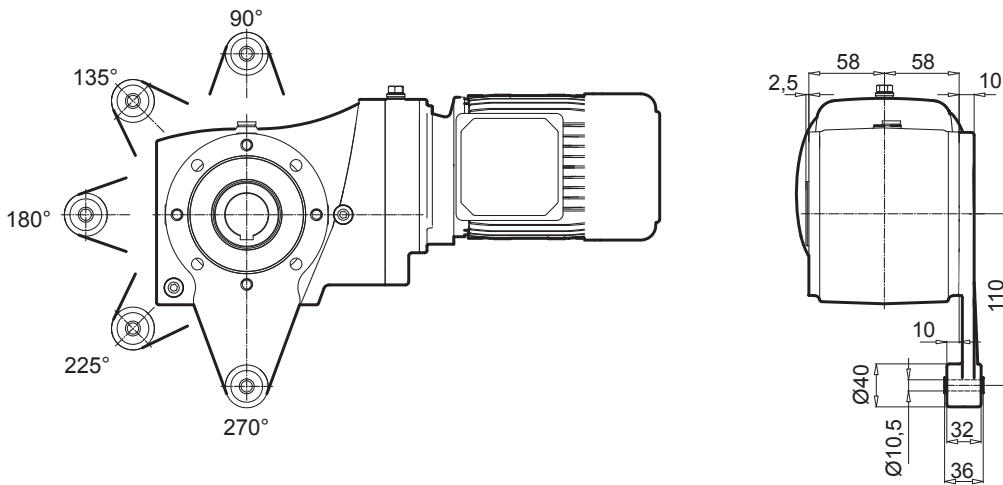

# SK 93172.1

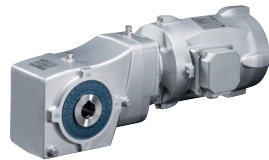

## SK 93172.1 V

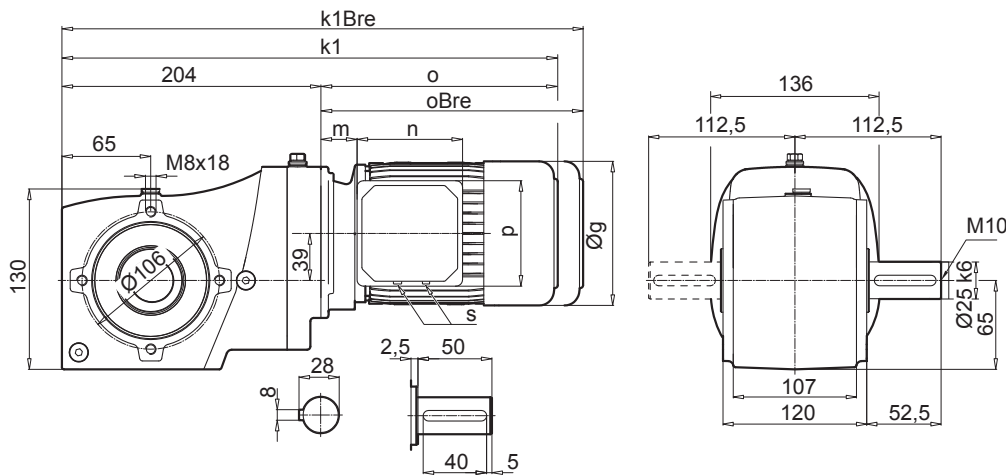

## SK 93172.1 A

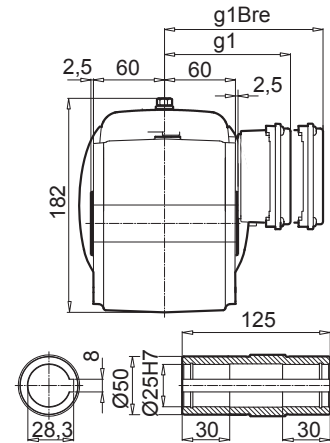

## SK 93172.1 VF

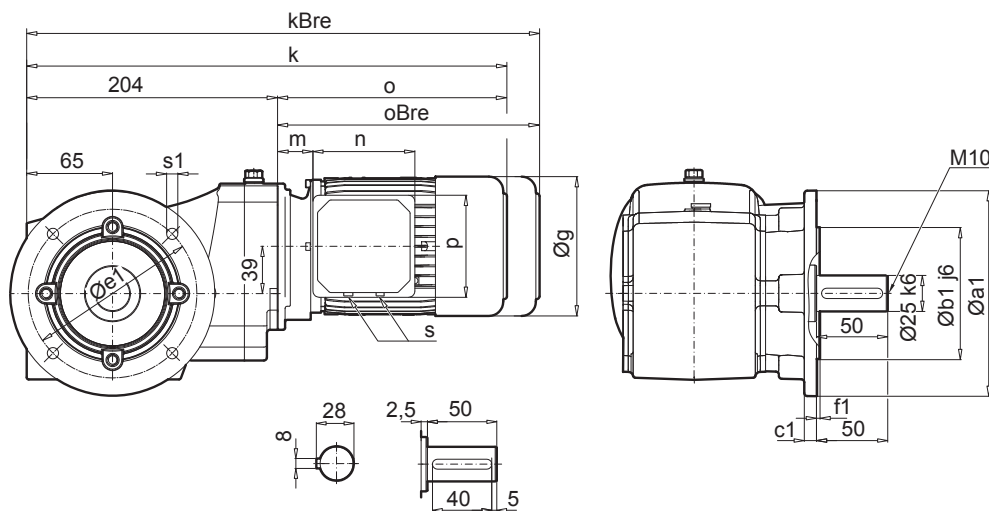

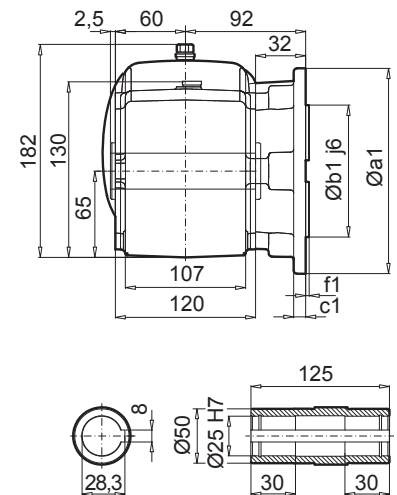

## SK 93172.1 AF



a1	b1	c1	e1	f1	s1
160	110	12	130	3,5	9

IE1 IE2 IE3	63 S / L - SP / LP	71 S / L - SP / LP	80 S / L SH / LH - / LP	90 S / L SH / LH SP / LP			
<b>g</b>	130	145	165	183			
<b>g1 / g1Bre</b>	115 / 123	124 / 132	142 / 142	147 / 147			
<b>k1 / k1Bre</b>	396 / 452	418 / 476	440 / 504	480 / 555			
<b>o / oBre</b>	192 / 248	214 / 272	236 / 300	276 / 351			
<b>m / mBre</b>	12 / 19	20 / 27	22 / 26	26 / 30			
<b>n / nBre</b>	100 / 134	100 / 134	114 / 153	114 / 153			
<b>p / pBre</b>	100 / 89	100 / 89	114 / 108	114 / 108			
<b>s</b>	M20 x 1,5	M20 x 1,5	M25 x 1,5	M25 x 1,5			



W ⇨ B51

IEC ⇨ B53



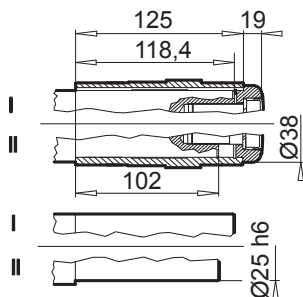

SK 93172.1 AB



SK 93172.1 ASH

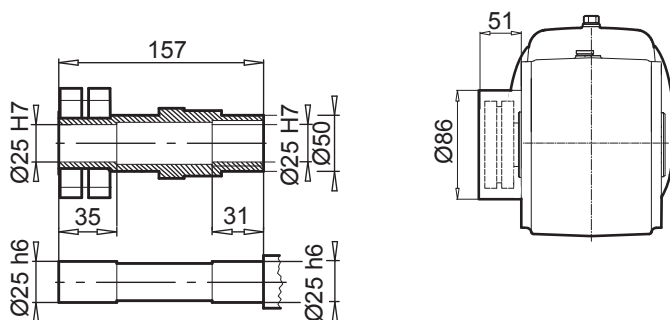

SK 93172.1 AD

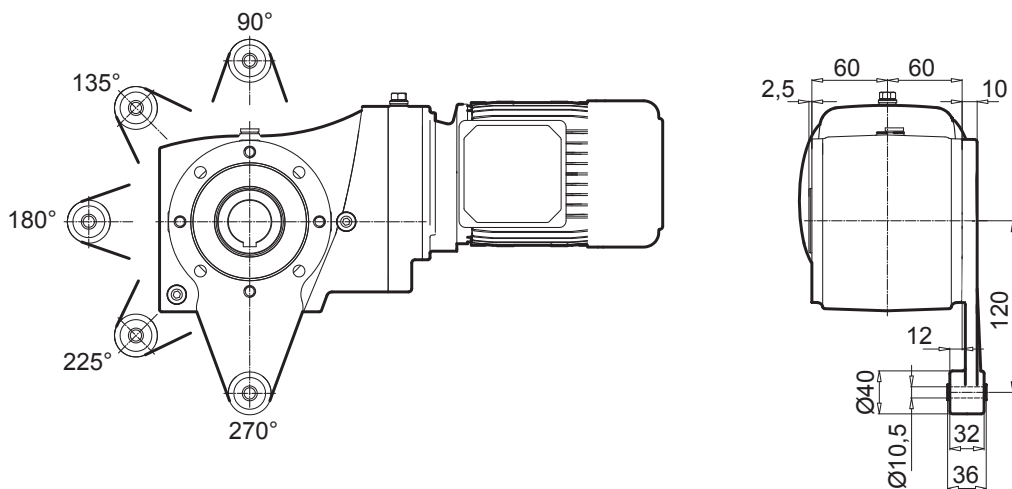

# SK 93372.1

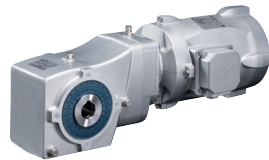

## SK 93372.1 V

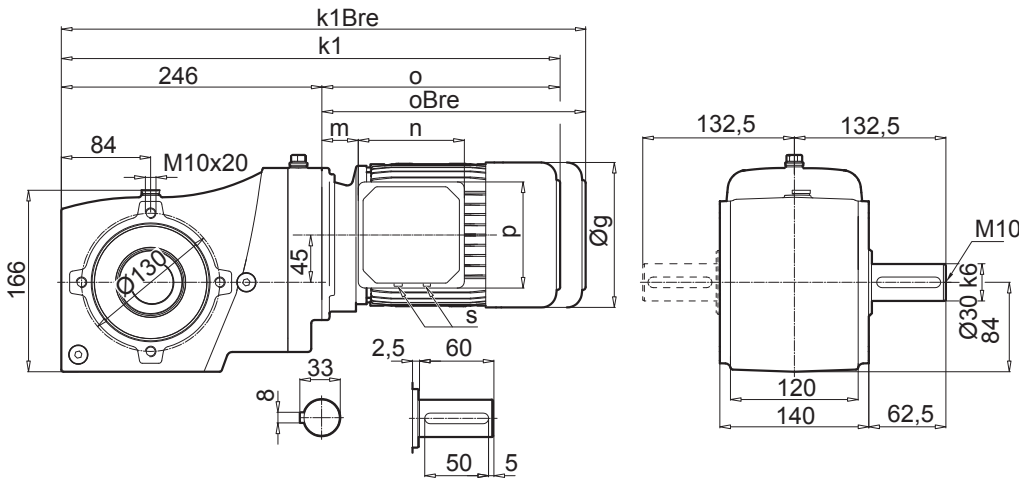

## SK 93372.1 A

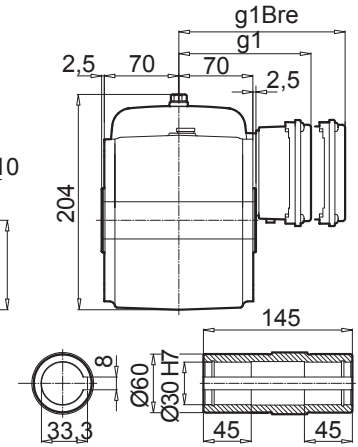

## SK 93372.1 VF

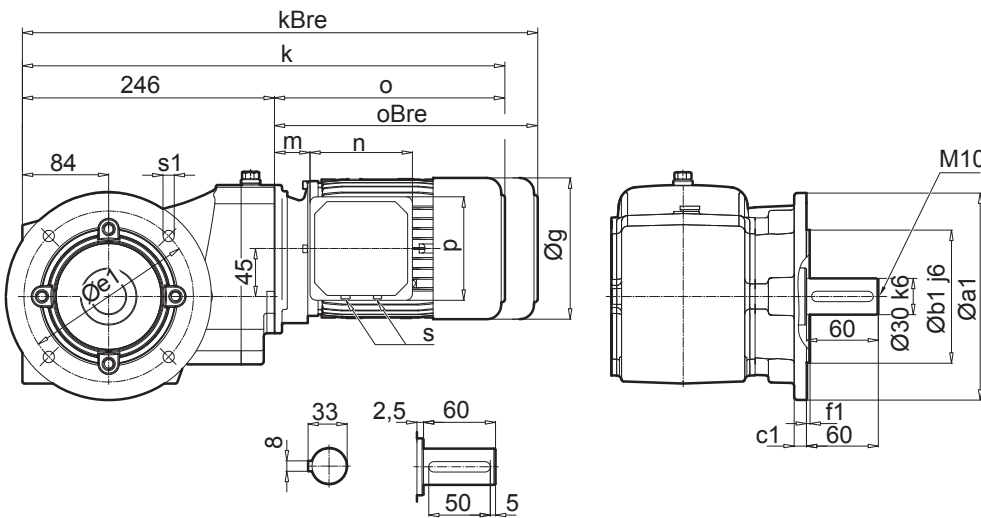

## SK 93372.1 AF

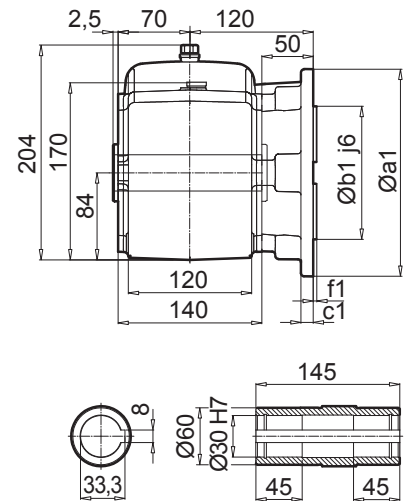

a1	b1	c1	e1	f1	s1
160	110	12	130	3,5	9
200	130	12	165	3,5	11

IE1 IE2 IE3	63 S / L - SP / LP	71 S / L - SP / LP	80 S / L SH / LH - / LP	90 S / L SH / LH SP / LP	100 L / LA LH / AH LP / AP		
<b>g</b>	130	145	165	183	201		
<b>g1 / g1Bre</b>	115 / 123	124 / 132	142 / 142	147 / 147	169 / 173		
<b>k1 / k1Bre</b>	442 / 498	482 / 540	507 / 571	548 / 623	578 / 669		
<b>o / oBre</b>	196 / 252	236 / 294	261 / 325	302 / 377	332 / 423		
<b>m / mBre</b>	16 / 23	42 / 49	47 / 51	52 / 56	58 / 62		
<b>n / nBre</b>	100 / 134	100 / 134	114 / 153	114 / 153	114 / 153		
<b>p / pBre</b>	100 / 89	100 / 89	144 / 108	144 / 108	144 / 108		
<b>s</b>	M20 x 1,5	M20 x 1,5	M25 x 1,5	M25 x 1,5	M25 x 1,5		

W ⇒ B51

IEC ⇒ B54



SK 93372.1 AB

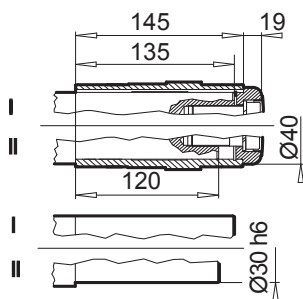

SK 93372.1 ASH

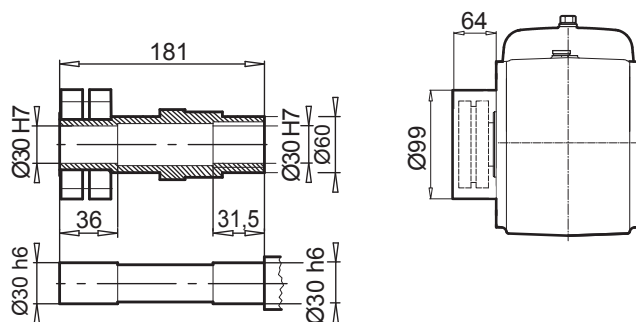

SK 93372.1 AD

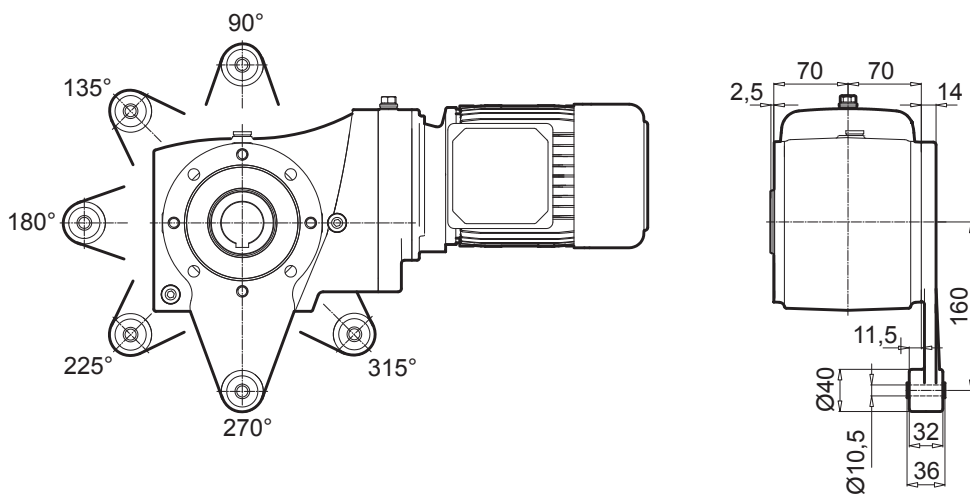

# SK 93672.1

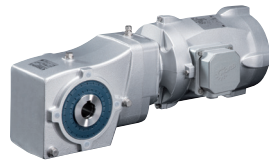

## SK 93672.1 V

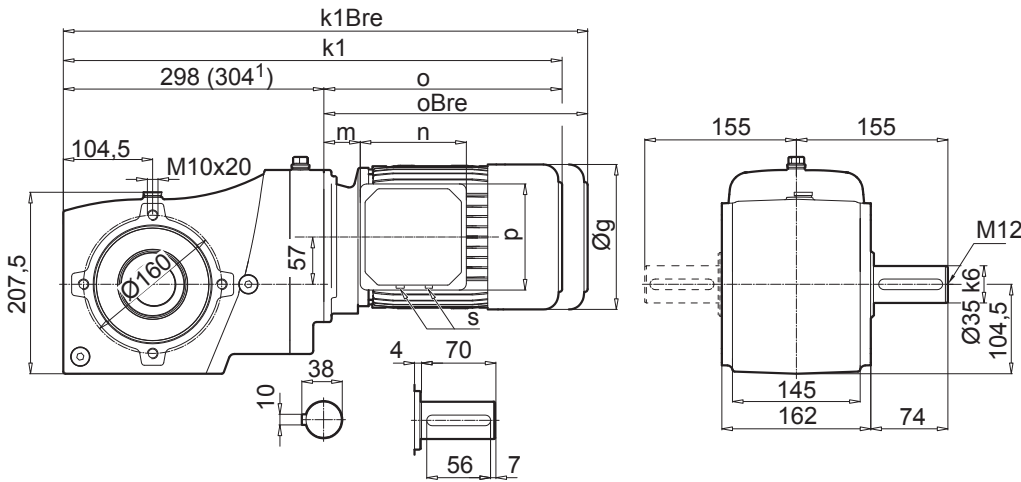

## SK 93672.1 A

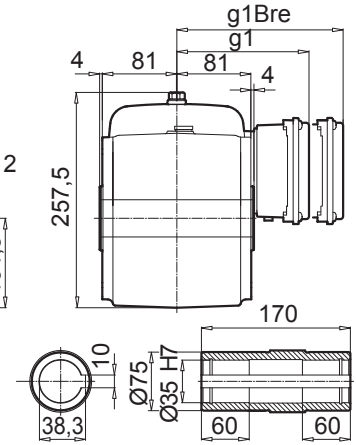

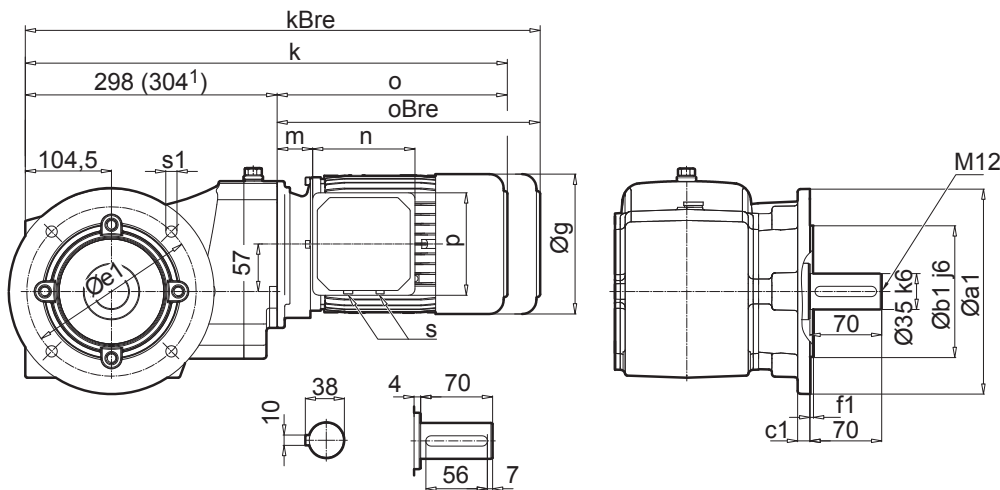

## SK 93672.1 VF

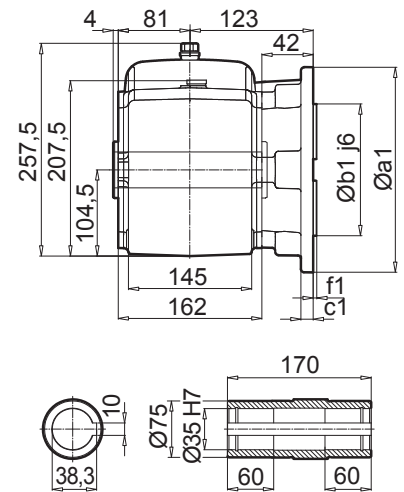

## SK 93672.1 VF



a1	b1	c1	e1	f1	s1
160	110	10	130	3,5	9
200	130	12	165	3,5	11,4

IE1 IE2 IE3	71 S / L - SP / LP	80 S / L SH / LH - / LP	90 S / L SH / LH SP / LP	100 L / LA LH / AH LP / AP	112 M - -	112 - MH MP	<sup>1)</sup> 132 S / M / MA SH / MH / - SP / MP / -	
g	145	165	183	201	228	228	266	
g1 / g1Bre	124 / 132	142 / 142	147 / 147	169 / 173	179 / 182	179 / 182	204 / 201	 W ⇨ B51
k1 / k1Bre	534 / 592	559 / 623	600 / 675	630 / 721	653 / 746	678 / 771	739 / 846	
o / oBre	236 / 294	261 / 325	302 / 377	332 / 423	355 / 448	380 / 473	435 / 542	
m / mBre	42 / 49	47 / 51	52 / 56	58 / 62	64 / 67	64 / 67	71 / 62	
n / nBre	100 / 134	114 / 153	114 / 153	114 / 153	114 / 153	114 / 153	122 / 185	
p / pBre	100 / 89	114 / 108	114 / 108	114 / 108	114 / 108	114 / 108	122 / 139	
s	M20 x 1,5	M25 x 1,5	M25 x 1,5	M25 x 1,5	M25 x 1,5	M25 x 1,5	M25 x 1,5	 IEC ⇨ B55



SK 93672.1 AB

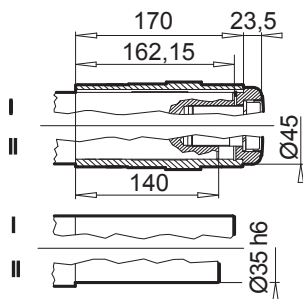

SK 93672.1 ASH

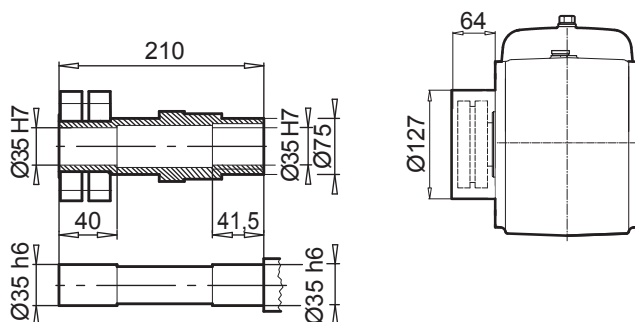

SK 93672.1 AD

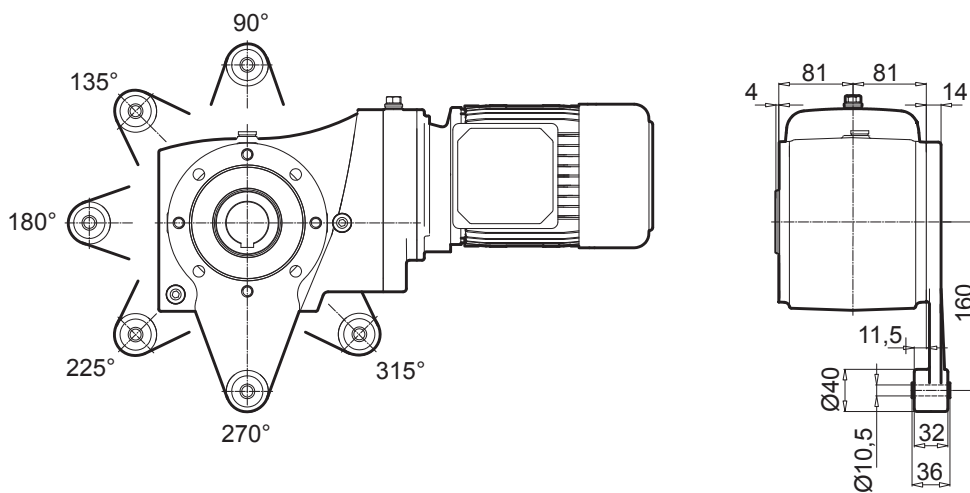

# SK 93772.1

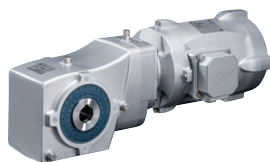

## SK 93772.1 V

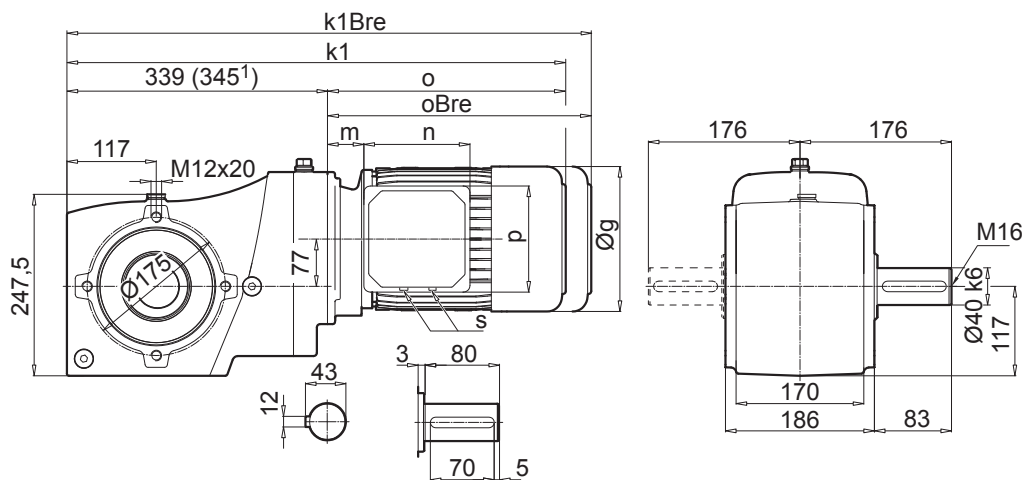

## SK 93772.1 A

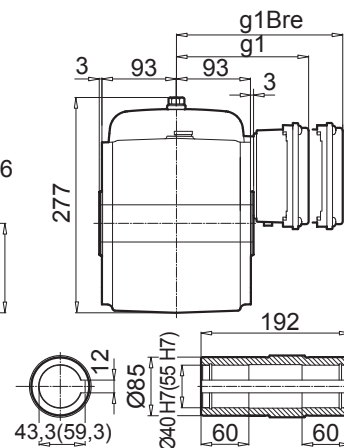

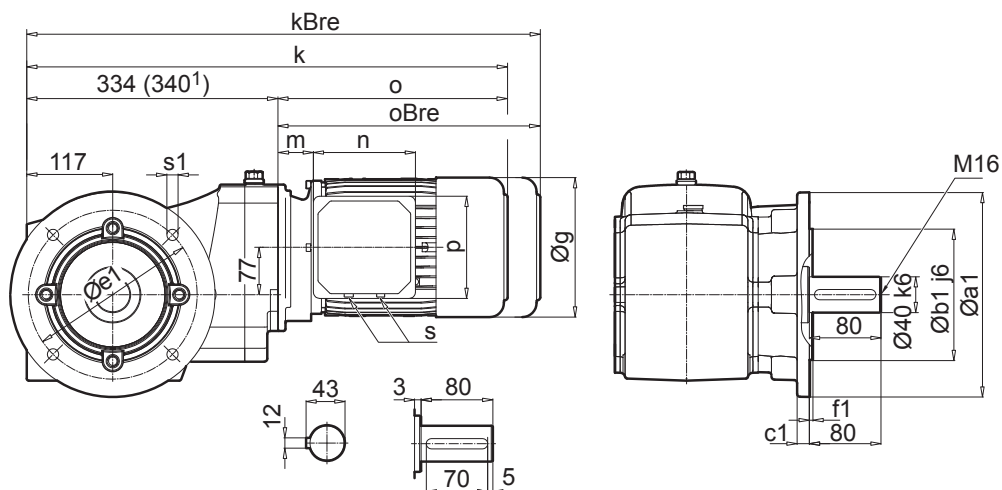

## SK 93772.1 VF

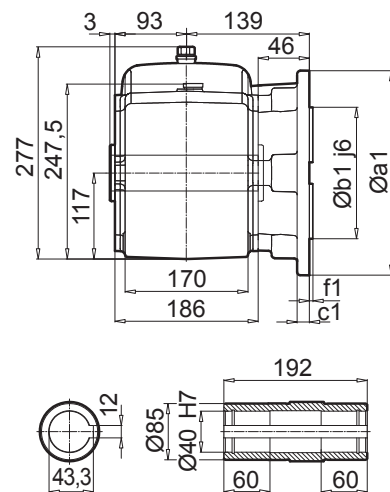

## SK 93772.1 AF



a1	b1	c1	e1	f1	s1
250	180	15	215	4	13,5

IE1 IE2 IE3	71 S / L - SP / LP	80 S / L SH / LH - / LP	90 S / L SH / LH SP / LP	100 L / LA LH / AH LP / AP	112 M -	112 - MH MP	<sup>1)</sup> 132 S / M / MA SH / MH / - SP / MP / -	
g	145	165	183	201	228	228	266	
g1 / g1Bre	124 / 132	142 / 142	147 / 147	169 / 173	179 / 182	179 / 182	204 / 201	 W ⇔ B51
k1 / k1Bre	575 / 633	600 / 664	641 / 716	671 / 762	694 / 787	719 / 812	780 / 887	
o / oBre	236 / 294	261 / 325	302 / 377	332 / 423	355 / 448	380 / 473	435 / 542	
m / mBre	42 / 49	47 / 51	52 / 56	58 / 62	64 / 67	64 / 67	71 / 62	
n / nBre	100 / 134	114 / 153	114 / 153	114 / 153	114 / 153	114 / 153	122 / 185	
p / pBre	100 / 89	114 / 108	114 / 108	114 / 108	114 / 108	114 / 108	122 / 139	
s	M20 x 1,5	M25 x 1,5	M25 x 1,5	M25 x 1,5	M25 x 1,5	M25 x 1,5	M25 x 1,5	 IEC ⇔ B56



SK 93772.1 AB

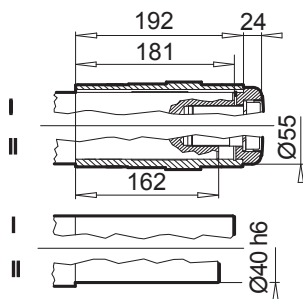

SK 93772.1 ASH

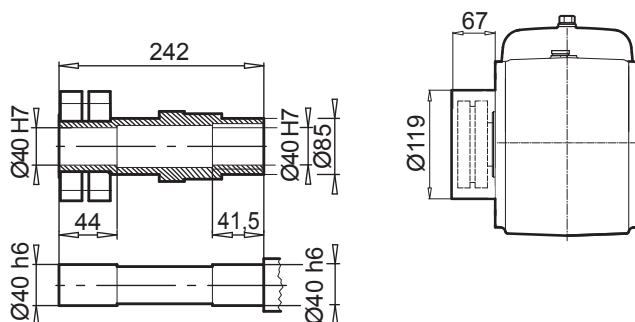

SK 93772.1 AD

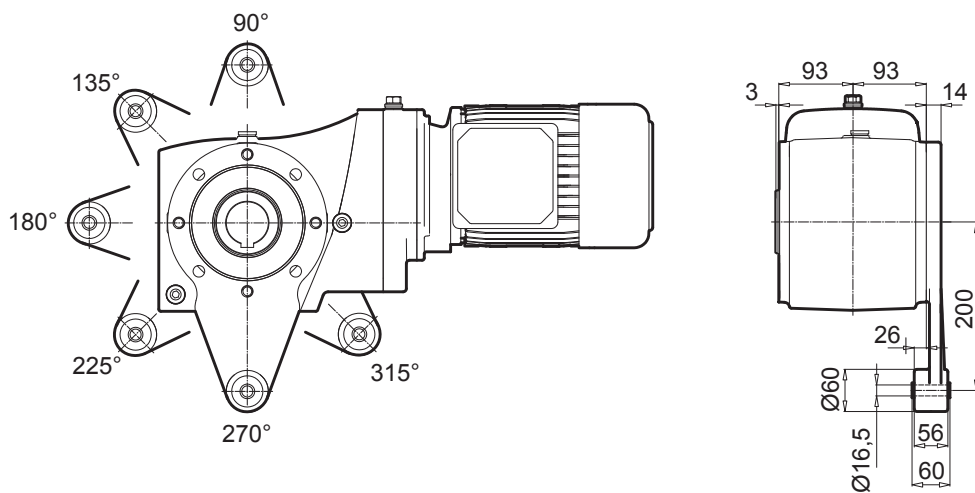







SK 920072.1 V (A) - W  
SK 92072.1 V (A) - W

SK 920072.1 VF (AF) - W  
SK 92072.1 VF (AF) - W

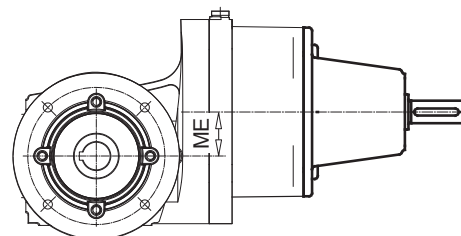
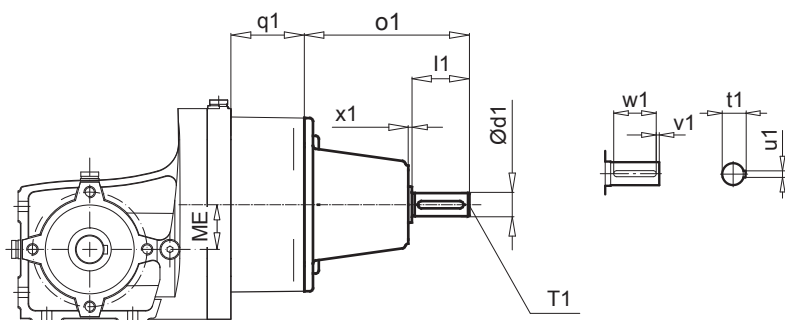

SK 92172.1 V (A) - W

SK 92172.1 VF (AF) - W

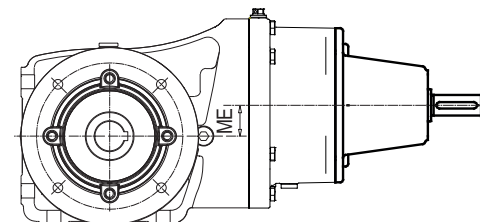
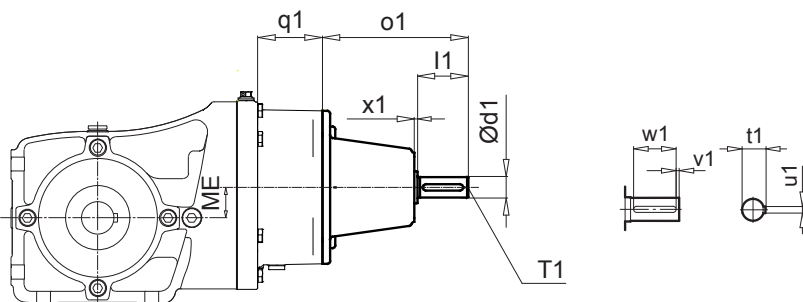

Type	q1
SK 920072.1	51,5
SK 92072.1	46,0
SK 92172.1	44,5

SK 92372.1 V (A) - W  
SK 92672.1 V (A) - W  
SK 92772.1 V (A) - W

SK 92372.1 VF (AF) - W  
SK 92672.1 VF (AF) - W  
SK 92772.1 VF (AF) - W

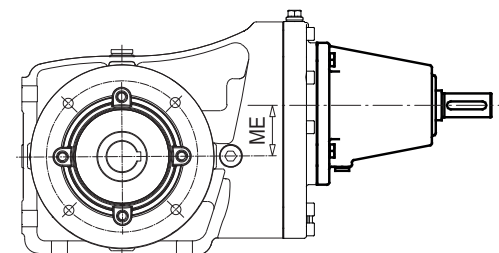
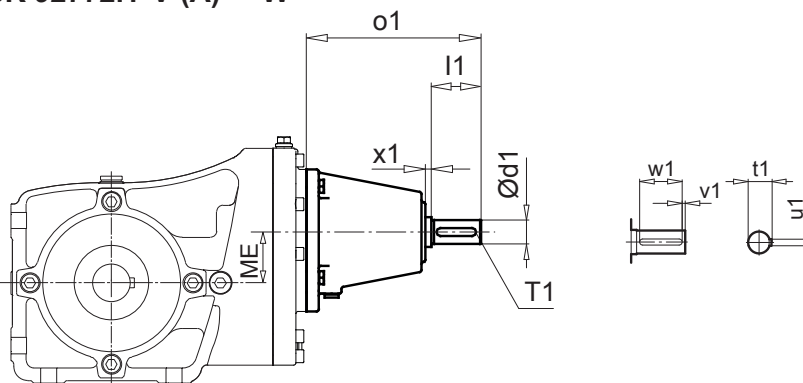

Type	ME	d1	l1	o1	x1	u1	t1	v1	w1	T1
SK 920072.1 V (A) / SK 920072.1 VF (AF)	31	16	40	115	2,5	6	22,5	4	32	M6
SK 92072.1 V (A) / SK 92072.1 VF (AF)	31	16	40	115	2,5	5	18	4	32	M6
SK 92172.1 V (A) / SK 92172.1 VF (AF)	39	16	40	115	2,5	5	18	4	32	M6
SK 92372.1 V (A) / SK 92372.1 VF (AF)	45	24	50	178	8	8	27	5	40	M8
SK 92672.1 V (A) / SK 92672.1 VF (AF)	57	24	50	178	8	8	27	5	40	M8
SK 92772.1 V (A) / SK 92772.1 VF (AF)	77	24	50	178	8	8	27	5	40	M8

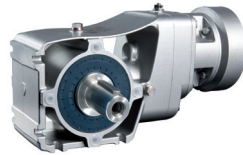

SK 920072.1 V (A) - IEC 56 ... 80  
 SK 92072.1 V (A) - IEC 56 ... 80

SK 920072.1 VF (AF) - IEC 56 ... 80  
 SK 92072.1 VF(AF) - IEC 56 ... 80

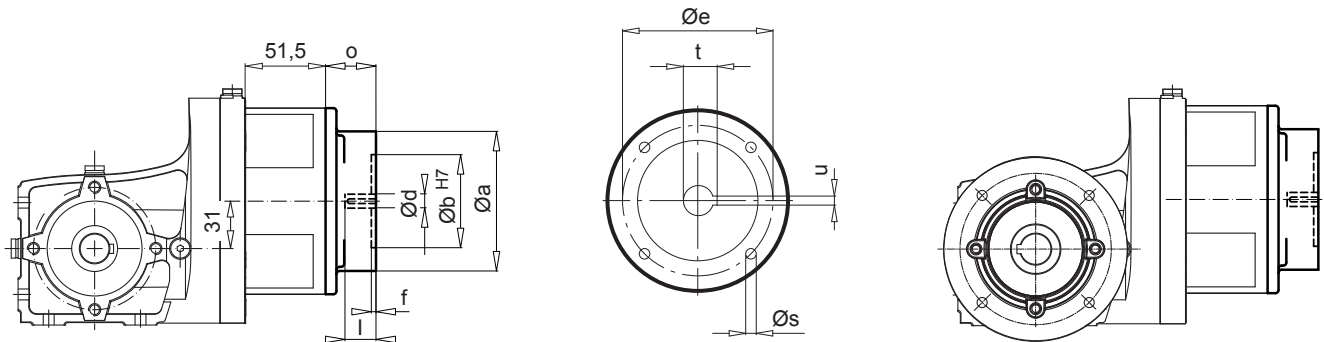

IEC	a	b	e	f	s	o	d	l	t	u
IEC 56 - C105	105	70	85	3	7	33	9	20	11,4	3
IEC 56 - A120	90	60	75	3	6	33				
IEC 63 - C90 *	90	60	75	3	6	33	11	23	12,8	4
IEC 63 - C120	120	80	100	3,5	5	33				
IEC 63 - A140	140	95	115	3,5	9	33				
IEC 71 - C105 *	105	70	85	3	7	33	14	30	16,3	5
IEC 71 - C140	140	95	115	3,5	9	33				
IEC 71 - A160	160	110	130	4	9	33				
IEC 80 - C120 *	120	80	100	3,5	7	33	19	40	21,8	6
IEC 80 - C160	160	110	130	4	9	33				
IEC 80 - A200	200	130	165	4	M10x20	32				

\* IEC-Advantages row

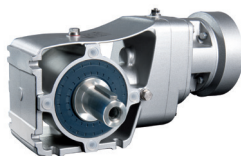

SK 92172.1 V (A) - IEC 56...90

SK 92172.1 VF(AF) - IEC 56...90

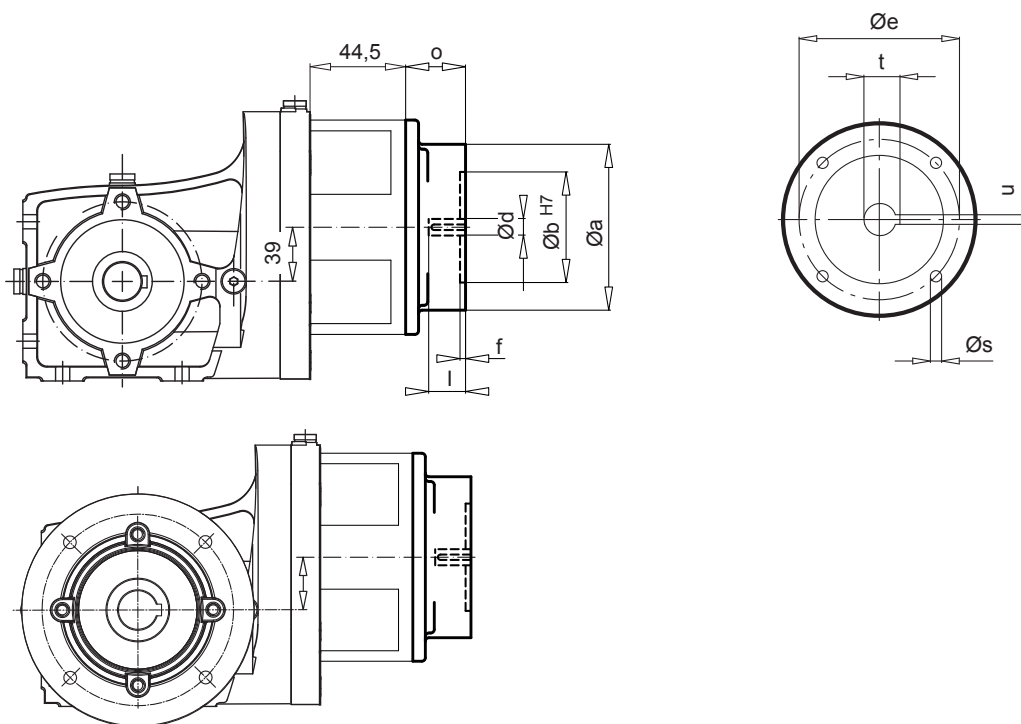

IEC	a	b	e	f	s	o	d	l	t	u
IEC 56 - C105	105	70	85	3	7	33	9	20	11,4	3
IEC 56 - A120	120	80	100	3,5	7	33				
IEC 63 - C90 *	90	60	75	3	6	33	11	23	12,8	4
IEC 63 - C120	120	80	100	3,5	7	33				
IEC 63 - A140	140	95	115	3,5	9	33				
IEC 71 - C105 *	105	70	85	3	7	33	14	30	16,3	5
IEC 71 - C140	140	95	115	3,5	9	33				
IEC 71 - A160	160	110	130	4	9	33				
IEC 80 - C120 *	120	80	100	3,5	7	33	19	40	21,8	6
IEC 80 - C160	160	110	130	4	9	33				
IEC 80 - A200	200	130	165	4	M10x20	33				
IEC 90 - C140 *	140	95	115	3,5	9	46	24	50	27,3	8
IEC 90 - C160	160	110	130	4	9	46				
IEC 90 - A200	200	130	165	4	M10x20	46				

\* IEC-Advantages row

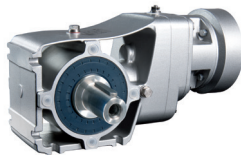

SK 92372.1 V (A) - IEC 63...90

SK 92372.1 VF(AF) - IEC 63...90

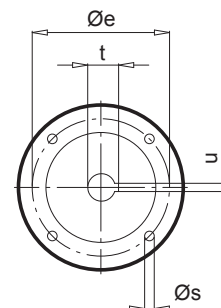
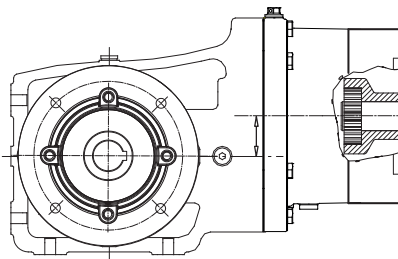
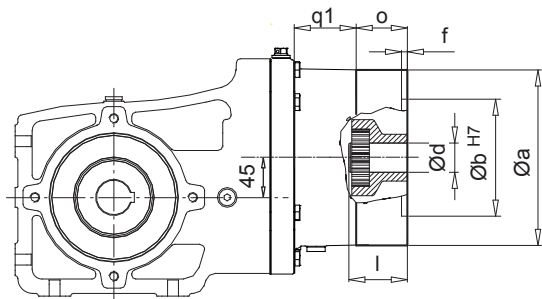

$i_{ges}$	q1
$\geq 18,33$	56
$< 18,33$	40

IEC	a	b	e	f	s	o	d	l	t	u
IEC 63 - C90 *	90	60	75	3	6	33	11	23	12,8	4
IEC 63 - C120	120	80	100	3,5	7	33				
IEC 63 - A140	140	95	115	3,5	9	33				
IEC 71 - C105 *	105	70	85	3	7	33	14	30	16,3	5
IEC 71 - C140	140	95	115	3,5	9	33				
IEC 71 - A160	160	110	130	4	9	33				
IEC 80 - C120 *	120	80	100	3,5	7	33	19	40	21,8	6
IEC 80 - C160	160	110	130	4	9	33				
IEC 80 - A200	200	130	165	4	M10x20	33				
IEC 90 - C140 *	140	95	115	3,5	9	46	24	50	27,3	8
IEC 90 - C160	160	110	130	4	9	46				
IEC 90 - A200	200	130	165	4	M10x20	46				

\* IEC-Advantages row

SK 92372.1 V (A) - IEC 100

SK 92372.1 VF(AF) - IEC 100

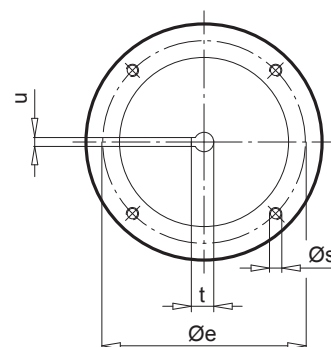
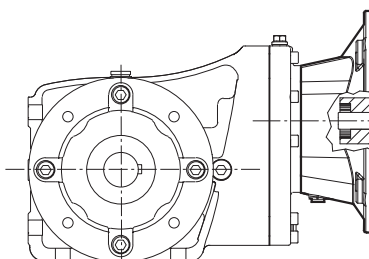
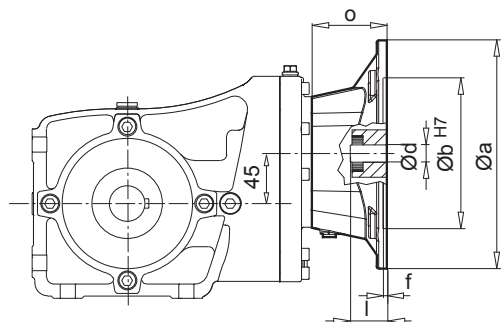

IEC	a	b	e	f	s	o	d	l	t	u
IEC 100	250	180	215	5	M12	82	28	60	31,3	8

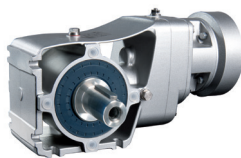

SK 92672.1 V (A) - IEC 63...90

SK 92672.1 VF(AF) - IEC 63...90

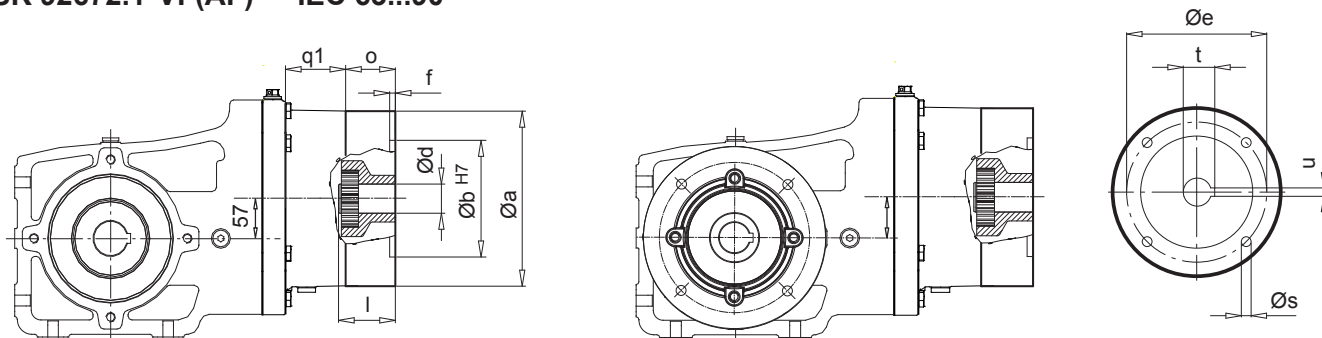

$i_{ges}$	q1
$\geq 18,21$	56
$< 18,21$	40

IEC	a	b	e	f	s	o	d	l	t	u
IEC 63 - C90 *	90	60	75	3	6	33	11	23	12,8	4
IEC 63 - C120	120	80	100	3,5	7	33				
IEC 63 - A140	140	95	115	3,5	9	33				
IEC 71 - C105 *	105	70	85	3	7	33	14	30	16,3	5
IEC 71 - C140	140	95	115	3,5	9	33				
IEC 71 - A160	160	110	130	4	9	33				
IEC 80 - C120 *	120	80	100	3,5	7	33	19	40	21,8	6
IEC 80 - C160	160	110	130	4	9	33				
IEC 80 - A200	200	130	165	4	M10x20	33				
IEC 90 - C140 *	140	95	115	3,5	9	46	24	50	27,3	8
IEC 90 - C160	160	110	130	4	9	46				
IEC 90 - A200	200	130	165	4	M10x20	46				

\* IEC-Advantages row

SK 92672.1 V (A) - IEC 100...132

SK 92672.1 VF(AF) - IEC 100...132

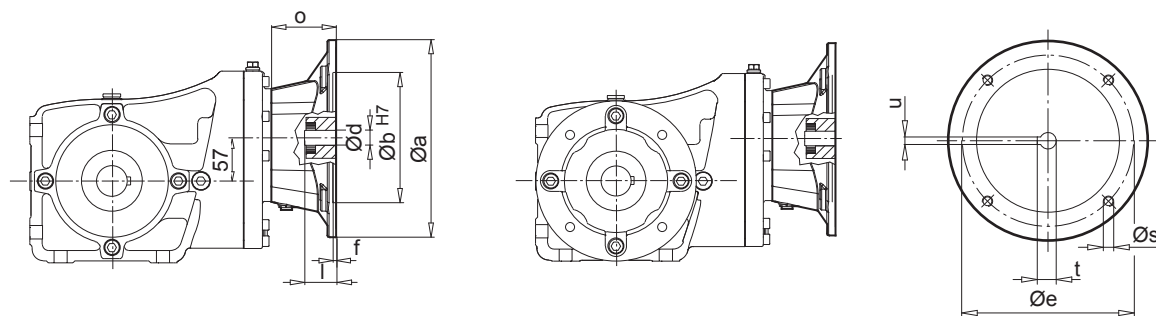

IEC	a	b	e	f	s	o	d	l	t	u
IEC 100	250	180	215	5	M12	82	28	60	31,3	8
IEC 112	250	180	215	5	M12	82	28	60	31,3	8
IEC 132	300	230	265	5	M12	111	38	80	41,3	10

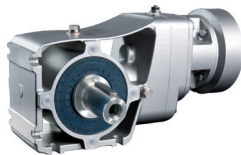

SK 92772.1 V (A) - IEC 63...90

SK 92772.1 VF(AF) - IEC 63...90

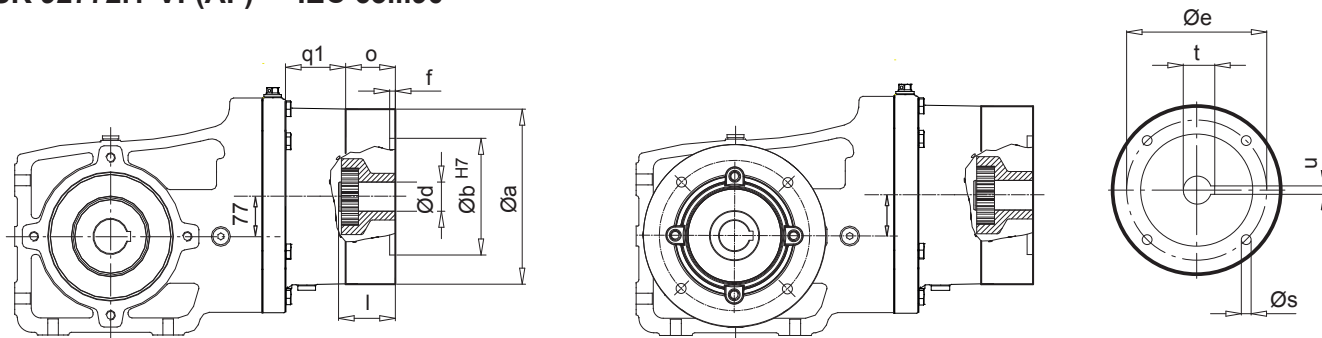

$i_{ges}$	q1
$\geq 28,38$	56
$< 28,38$	40

IEC	a	b	e	f	s	o	d	l	t	u
IEC 63 - C90 *	90	60	75	3	6	33	11	23	12,8	4
IEC 63 - C120	120	80	100	3,5	7	33				
IEC 63 - A140	140	95	115	3,5	9	33				
IEC 71 - C105 *	105	70	85	3	7	33	14	30	16,3	5
IEC 71 - C140	140	95	115	3,5	9	33				
IEC 71 - A160	160	110	130	4	9	33				
IEC 80 - C120 *	120	80	100	3,5	7	33	19	40	21,8	6
IEC 80 - C160	160	110	130	4	9	33				
IEC 80 - A200	200	130	165	4	M10x20	33				
IEC 90 - C140 *	140	95	115	3,5	9	46	24	50	27,3	8
IEC 90 - C160	160	110	130	4	9	46				
IEC 90 - A200	200	130	165	4	M10x20	46				

\* IEC-Advantages row

SK 92772.1 V (A) - IEC 100...132

SK 92772.1 VF(AF) - IEC 100...132

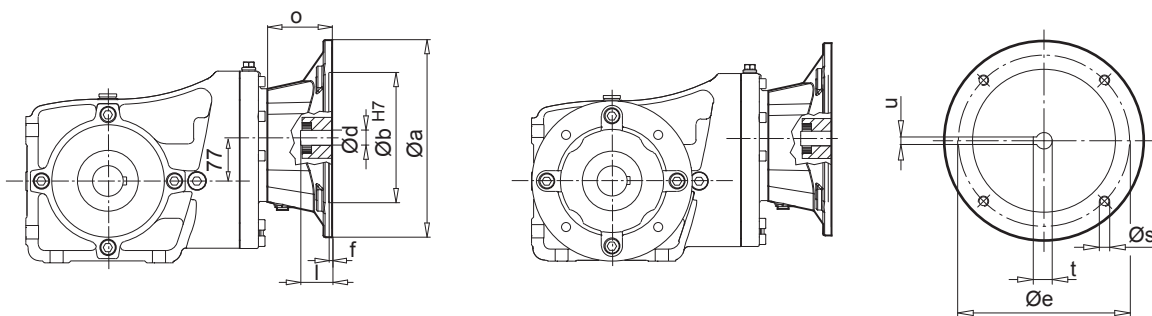

IEC	a	b	e	f	s	o	d	l	t	u
IEC 100	250	180	215	5	M12	82	28	60	31,3	8
IEC 112	250	180	215	5	M12	82	28	60	31,3	8
IEC 132	300	230	265	5	M12	111	38	80	41,3	10

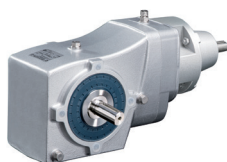

SK 930072.1 V (A) - W  
SK 93072.1 V (A) - W

SK 930072.1 VF (AF) - W  
SK 93072.1 VF (AF) - W

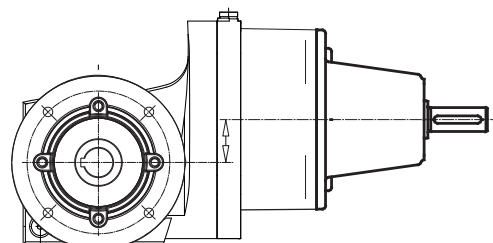
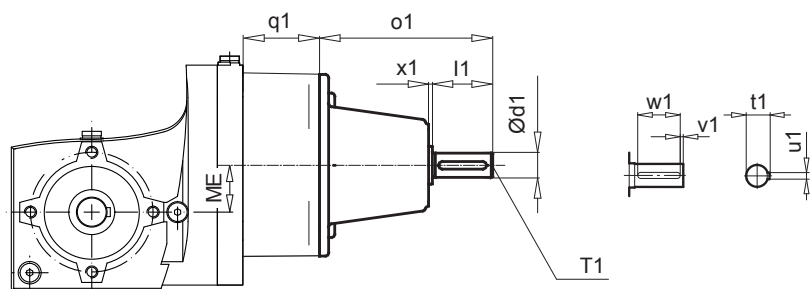

SK 93172.1 V (A) - W

SK 93172.1 VF (AF) - W

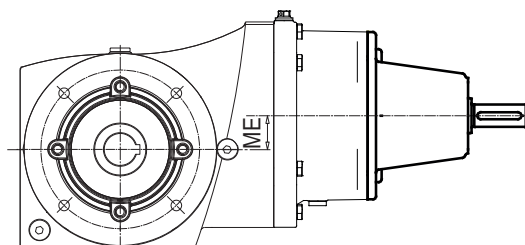
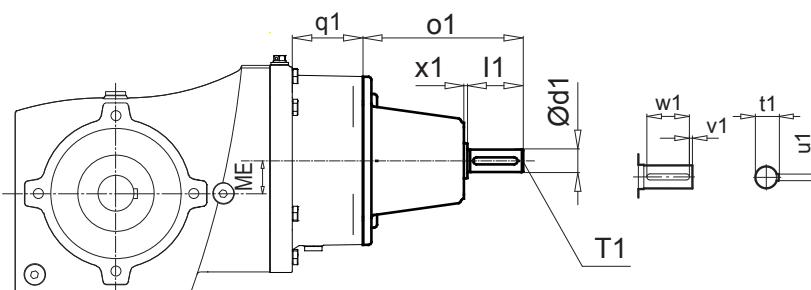

Type	q1
SK 930072.1	51,5
SK 93072.1	46
SK 93172.1	44,5

SK 93372.1 V (A) - W  
SK 93672.1 V (A) - W  
SK 93772.1 V (A) - W

SK 93372.1 VF (AF) - W  
SK 93672.1 VF (AF) - W  
SK 93772.1 VF (AF) - W

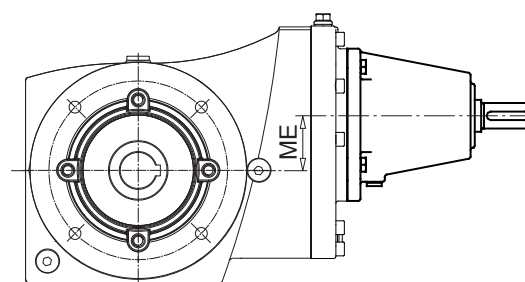
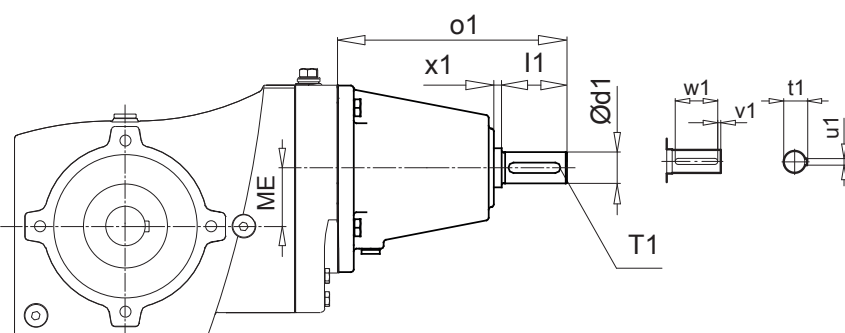

Type	ME	d1	l1	o1	x1	u1	t1	v1	w1	T1
SK 930072.1 V (A) / SK 930072.1 VF (AF)	31	16	40	115	2,5	5	18	4	32	M6
SK 93072.1 V (A) / SK 93072.1 VF (AF)	31	16	40	115	2,5	5	18	4	32	M6
SK 93172.1 V (A) / SK 93172.1 VF (AF)	39	16	40	115	2,5	5	18	4	32	M6
SK 93372.1 V (A) / SK 93372.1 VF (AF)	45	24	50	178	8	8	27	5	40	M8
SK 93672.1 V (A) / SK 93672.1 VF (AF)	57	24	50	178	8	8	27	5	40	M8
SK 93772.1 V (A) / SK 93772.1 VF (AF)	77	24	50	178	8	8	27	5	40	M8

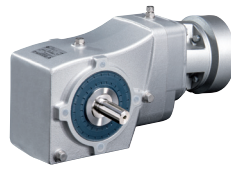

SK 930072.1 V (A) - IEC 56 ... 80  
 SK 93072.1 V (A) - IEC 56 ... 80

SK 930072.1 VF (AF) - IEC 56 ... 80  
 SK 93072.1 VF (AF) - IEC 56 ... 80

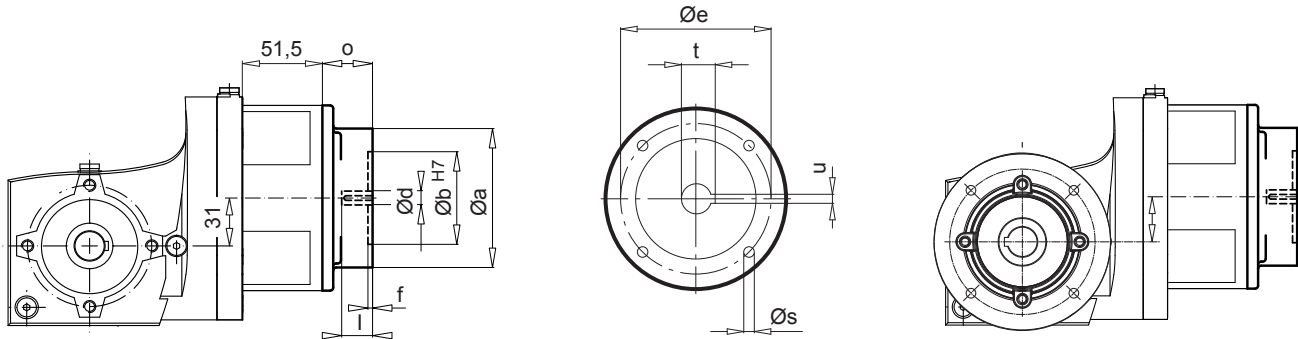

IEC	a	b	e	f	s	o	d	l	t	u
IEC 56 - C105	105	70	85	3	7	33	9	20	11,4	3
IEC 56 - A120	90	60	75	3	5,5	33				
IEC 63 - C90 *	90	60	75	3	5,5	33	11	23	12,8	4
IEC 63 - C120	120	80	100	4	5	33				
IEC 63 - A140	140	95	115	4	9	33				
IEC 71 - C105 *	105	70	85	3	7	33	14	30	16,3	5
IEC 71 - C140	140	95	115	4	9	33				
IEC 71 - A160	160	110	130	4	9	33				
IEC 80 - C120 *	120	80	100	4	6,6	33	19	40	21,8	6
IEC 80 - C160	160	110	130	4	9	33				
IEC 80 - A200	200	130	165	4	M10x20	33				

\* IEC-Advantages row



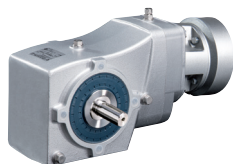

SK 93172.1 V (A) - IEC 56...90

SK 93172.1 VF(AF) - IEC 56...90

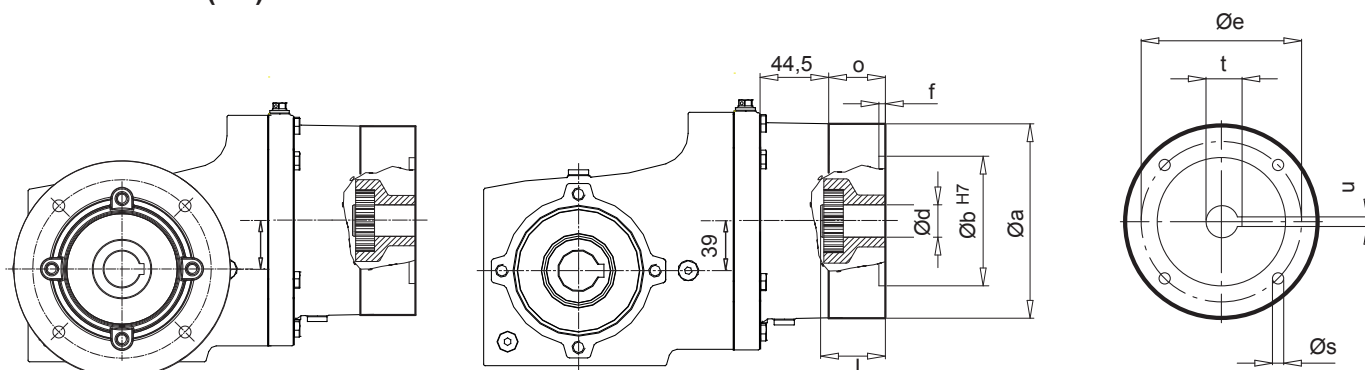

IEC	a	b	e	f	s	o	d	l	t	u
IEC 56 - C105	105	70	85	3	7	33	9	20	11,4	3
IEC 56 - A120	120	80	100	4	5	33				
IEC 63 - C90 *	90	60	75	3	5,5	33	11	23	12,8	4
IEC 63 - C120	120	80	100	4	5	33				
IEC 63 - A140	140	95	115	4	9	33				
IEC 71 - C105 *	105	70	85	3	7	33	14	30	16,3	5
IEC 71 - C140	140	95	115	4	9	33				
IEC 71 - A160	160	110	130	4	9	33				
IEC 80 - C120 *	120	80	100	4	7	33	19	40	21,8	6
IEC 80 - C160	160	110	130	4	9	33				
IEC 80 - A200	200	130	165	4	M10x20	33				
IEC 90 - C140 *	140	95	115	4	9	46	24	50	27,3	8
IEC 90 - C160	160	110	130	4	9	46				
IEC 90 - A200	200	130	165	4	M10x20	46				

\* IEC-Advantages row

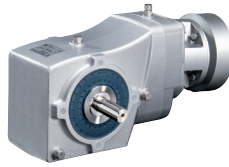

SK 93372.1 V (A) - IEC 63...90

SK 93372.1 VF(AF) - IEC 63...90

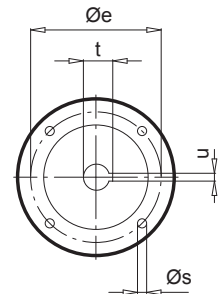
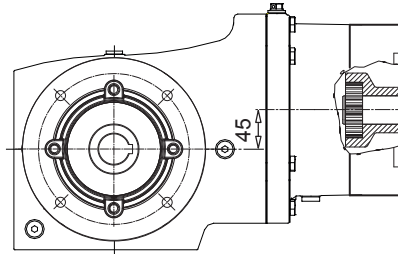
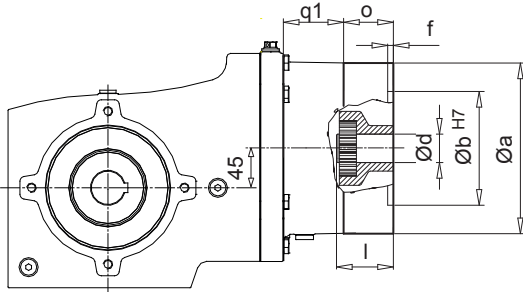

$i_{ges}$	q1
$\geq 18,33$	57
$< 18,33$	41

IEC	a	b	e	f	s	o	d	l	t	u
IEC 63 - C90 *	90	60	75	3	5,5	33	11	23	12,8	4
IEC 63 - C120	120	80	100	4	5	33				
IEC 63 - A140	140	95	115	4	9	33				
IEC 71 - C105 *	105	70	85	3	7	33	14	30	16,3	5
IEC 71 - C140	140	95	115	4	9	33				
IEC 71 - A160	160	110	130	4	9	33				
IEC 80 - C120 *	120	80	100	4	7	33	19	40	21,8	6
IEC 80 - C160	160	110	130	4	9	33				
IEC 80 - A200	200	130	165	4	M10x20	33				
IEC 90 - C140 *	140	95	115	4	9	46	24	50	27,3	8
IEC 90 - C160	160	110	130	4	9	46				
IEC 90 - A200	200	130	165	4	M10x20	46				

\* IEC-Advantages row

SK 93372.1 V (A) - IEC 100

SK 93372.1 VF(AF) - IEC 100

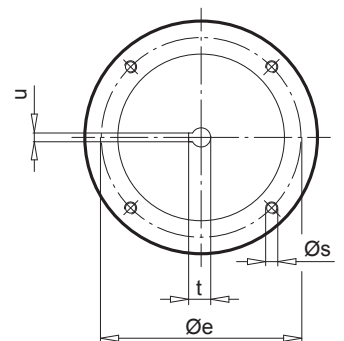
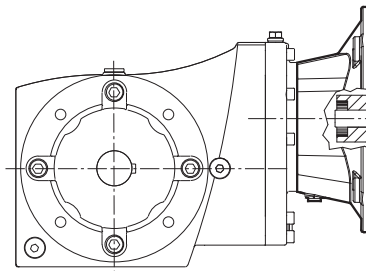
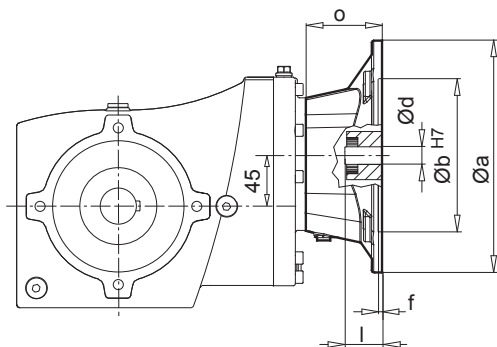

IEC	a	b	e	f	s	o	d	l	t	u
IEC 100	250	180	215	5	M12	83	28	60	31,3	8

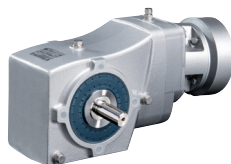
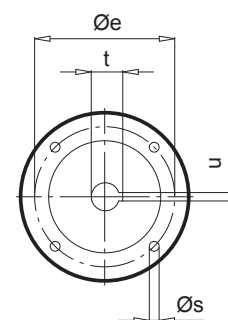
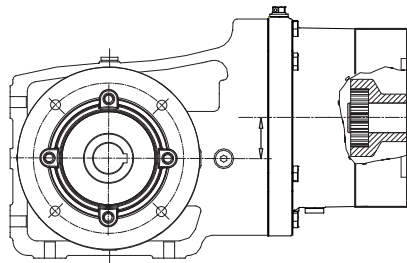
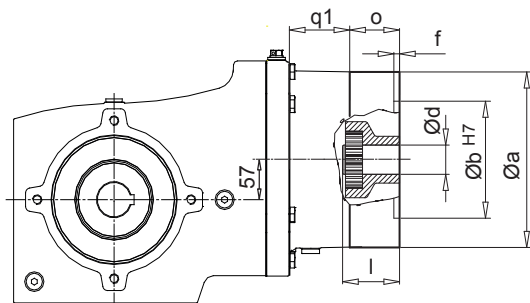
**SK 93672.1 V (A) - IEC 63...90**
**SK 93672.1 VF(AF) - IEC 63...90**

$i_{ges}$	q1
$\geq 18,21$	57
$< 18,21$	41

IEC	a	b	e	f	s	o	d	l	t	u
IEC 63 - C90 *	90	60	75	3	5,5	33	11	23	12,8	4
IEC 63 - C120	120	80	100	4	5	33				
IEC 63 - A140	140	95	115	4	9	33				
IEC 71 - C105 *	105	70	85	3	7	33	14	30	16,3	5
IEC 71 - C140	140	95	115	4	9	33				
IEC 71 - A160	160	110	130	4	9	33				
IEC 80 - C120 *	120	80	100	4	7	33	19	40	21,8	6
IEC 80 - C160	160	110	130	4	9	33				
IEC 80 - A200	200	130	165	4	M10x20	33				
IEC 90 - C140 *	140	95	115	4	9	46	24	50	27,3	8
IEC 90 - C160	160	110	130	4	9	46				
IEC 90 - A200	200	130	165	4	M10x20	46				

\* IEC-Advantages row

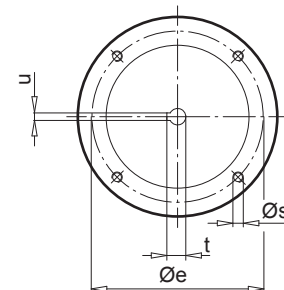
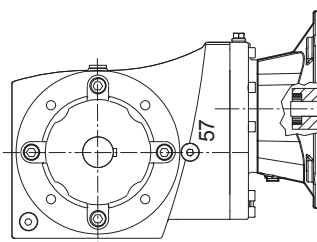
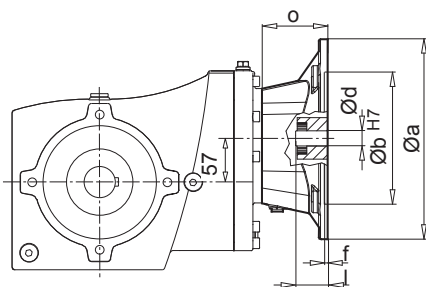
**SK 93672.1 V (A) - IEC 100...132**
**SK 93672.1 VF(AF) - IEC 100...132**

IEC	a	b	e	f	s	o	d	l	t	u
IEC 100	250	180	215	5	M12	82	28	60	31,3	8
IEC 112	250	180	215	5	M12	82	28	60	31,3	8
IEC 132	300	230	265	5	M12	111	38	80	41,3	10

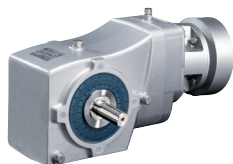

SK 93772.1 V (A) - IEC 63...90

SK 93772.1 VF(AF) - IEC 63...90

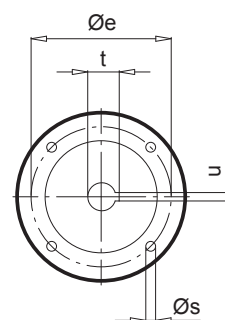
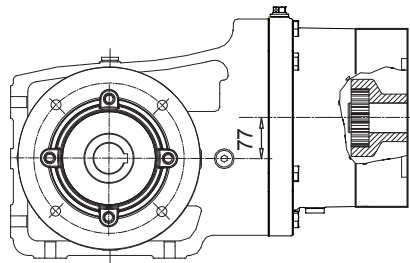
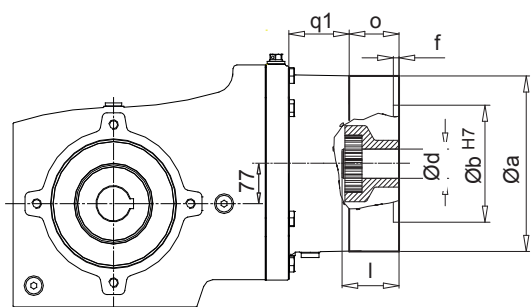

$i_{ges}$	q1
$\geq 28,38$	57
$< 28,38$	41

IEC	a	b	e	f	s	o	d	l	t	u
IEC 63 - C90 *	90	60	75	3	5,5	33	11	23	12,8	4
IEC 63 - C120	120	80	100	4	5	33				
IEC 63 - A140	140	95	115	4	9	33				
IEC 71 - C105 *	105	70	85	3	7	33	14	30	16,3	5
IEC 71 - C140	140	95	115	4	9	33				
IEC 71 - A160	160	110	130	4	9	33				
IEC 80 - C120 *	120	80	100	4	7	33	19	40	21,8	6
IEC 80 - C160	160	110	130	4	9	33				
IEC 80 - A200	200	130	165	4	M10x20	33				
IEC 90 - C140 *	140	95	115	4	9	46	24	50	27,3	8
IEC 90 - C160	160	110	130	4	9	46				
IEC 90 - A200	200	130	165	4	M10x20	46				

\* IEC-Advantages row

SK 93772.1 V (A) - IEC 100...132

SK 93772.1 VF(AF) - IEC 100...132

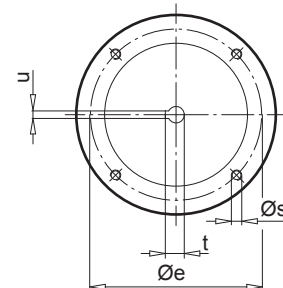
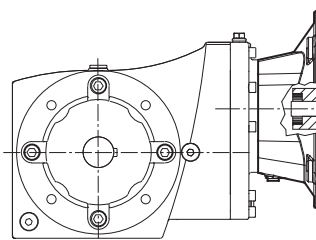
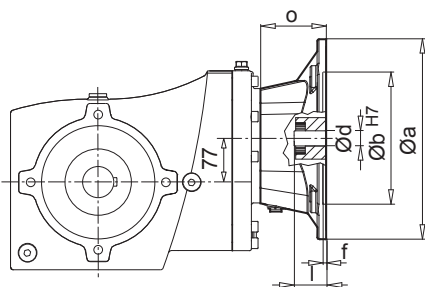

IEC	a	b	e	f	s	o	d	l	t	u
IEC 100	250	180	215	5	M12	82	28	60	31,3	8
IEC 112	250	180	215	5	M12	82	28	60	31,3	8
IEC 132	300	230	265	5	M12	111	38	80	41,3	10

## Casing-Foot mounting

SK 930072.1 - SK 93772.1

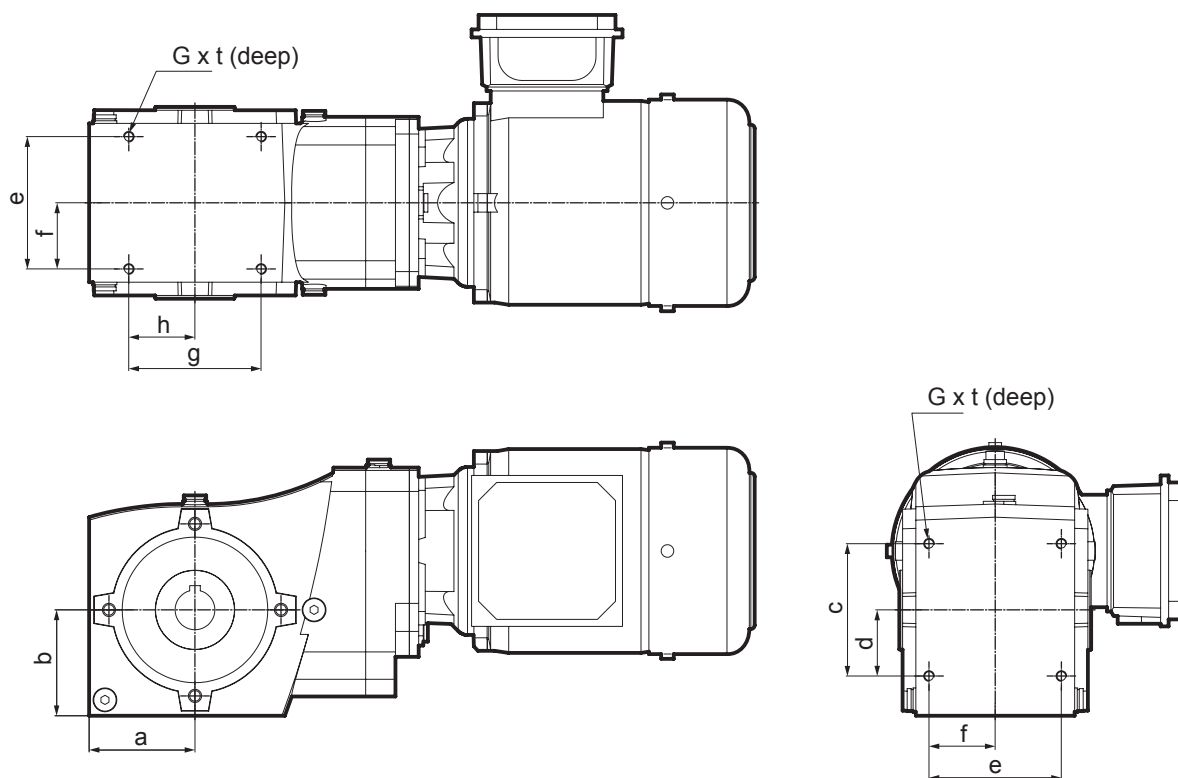

Type	a	b	c	d	e	f	g	h	t	G
	[mm]									
930072.1	50	50	60	30	75	37	60	30	8	M6
93072.1	56	56	70	35	90	45	70	35	8	M6
93172.1	63	63	80	40	90	45	80	40	11	M8
93372.1	80	80	100	50	100	50	100	50	11	M8
93672.1	100	100	120	63	120	60	120	60	15	M10
93772.1	112	112	140	70	140	70	140	70	15	M12



## G1000 Fixed speeds

UNICASE housing 50 Hz, 60 Hz

- NORDBLOC.1 Helical geared motors
- Helical geared motors
- Parallel geared motors
- Bevel geared motors
- Helical worm geared motors

## G4014 Electronic variable speed drives

- NORDBLOC.1 Helical geared motors
- Helical geared motors
- Parallel geared motors
- Bevel geared motors
- Helical worm geared motors

## G1050 MAXXDRIVE Industrial gear units

UNICASE housing 50 / 60 Hz

- Parallel-Axis
- Right-Angle

## G1035 UNIVERSAL Schneckengetriebe

- SI and SMI

F3018 Frequency inverter SK180E

F3020 Frequency inverter SK200E





**NORD DRIVESYSTEMS Group**

**Headquarters and Technology center**  
in Bargteheide close to Hamburg

**Innovative drive solutions**  
for more than 100 branches of industry

**Mechanical products**  
parallell shaft, helical gear, bevel gear and worm gear units

**Electrical products**  
IE2/IE3/IE4 motors

**Electronic products**  
centralised and decentralised frequency inverters,  
motor starters and field distribution systems

**7 state-of-the-art production plants**  
for all drive components

**Subsidiaries and distributors**  
**in 89 countries on 5 continents**  
provide local stocks, assembly, production,  
technical support and customer service

**More than 3,300 employees throughout the world**  
create customer oriented solutions

**[www.nord.com/locator](http://www.nord.com/locator)**

**Headquarters:**

**Getriebebau NORD GmbH & Co. KG**

Getriebebau-Nord-Straße 1

22941 Bargteheide, Germany

T: +49 (0) 4532 / 289-0

F: +49 (0) 4532 / 289-2253

info@nord.com, www.nord.com

**Member of the NORD DRIVESYSTEMS Group**

