

AUTOMATION SOLUTIONS



2019/2020

AUTOMATION SOLUTIONS

1	About Bosch Rexroth	2
2	Automation software	16
3	Control components	66
4	Drive components	192
5	Engineering software	370
6	Process control systems	392
7	Services	404
8	Training	420
9	Annex	426

ABOUT BOSCH REXROTH

1

**Bosch Rexroth – We automate
the Factory of the Future**

5

**Automation & Electrification Solutions
Business Unit in numbers**

6

Active partnership

9

Solution portfolio

10

Tailor-made automation solutions

13



Bosch Rexroth – We automate the Factory of the Future

As the world's leading supplier of drive and control technologies, Bosch Rexroth ensures efficient, powerful and safe motion in machines and systems of all types and sizes. More than 30 000 employees worldwide work on efficient and safe solutions in the areas of factory automation, system construction, engineering and mobile applications. Our solution portfolio ranges from automation solutions and hydraulics to linear motion and assembly technology. With technological excellence and unique industry knowledge, we support our customers in achieving their goals. What distinguishes us beyond: we combine the resources of a global player with the flexibility of a medium-sized company. For one goal: the success of our customers.

YOUR PARTNER IN AUTOMATION

The Automation & Electrification Solutions business unit at Bosch Rexroth offers a wide portfolio of drive and control technologies for factory automation and already implements intelligent system solutions today that make machines fit for the Internet of Things and your company future-proof. With the most powerful CNC and Motion Control on the market, we ensure maximum performance in your machines.

COMPREHENSIVE PRODUCTION EXPERTISE

As a leading supplier and user of industrial solutions in our own production facilities with more than 60 years of experience in electronics manufacturing, we have comprehensive know-how and valuable practical experience in the redesign of our own plants to Industry 4.0.

OUR PRODUCT PORTFOLIO

From PLC to CNC to Motion Control with integrated robotics: Our open control systems with scalable hardware and software offer optimal performance and maximum flexibility. Our electric drives complement the controls to form an overall system and cover the entire power range from 100 W to 4 MW.

- ▶ CNC
- ▶ Motion Control
- ▶ PLC & IoT
- ▶ Process Control
- ▶ Drives
- ▶ Services

Automation & Electrification Solutions Business Unit in numbers

> 3 500
EMPLOYEES



MORE THAN 
10 000
SATISFIED CUSTOMERS WORLDWIDE

20
industries



6 
Solution programs

360°
CONSULTING



i4.0
LEADING PROVIDER
AND USER

> 60
YEARS OF EXPERTISE
IN ELECTRONICS AND
MOTOR MANUFACTURING 

SALES AND SERVICE NETWORKS IN



80 countries



4

PRODUCTION AND R&D LOCATIONS



BENCHMARK

MOTION CONTROL



Active partnership

We at Bosch Rexroth support our customers throughout the engineering process – from system development and commissioning to production optimization. With durable products and a unique service concept, we permanently extend the product lifecycle of your existing machines so that you can reliably achieve ambitious targets.

- ▶ Comprehensive system development
- ▶ Safe commissioning
- ▶ Fast support and service
- ▶ Customized consultation

We serve as partners and aim for mutual exchange with customers, machine manufacturers and users. This is because only through cooperation can we meet the challenges of digital transformation.

AT HOME IN THE WORLD

Our global application network consists of local contacts and an international network for the 1st, 2nd and 3rd level support. Our specialists are available worldwide – also in your vicinity. This way, we ensure at all times that you get comprehensive support if the occasion arises.

**PARTNERSHIP FOR BOSCH REXROTH MEANS:
At any time. World-wide. There for you.**

Solution portfolio

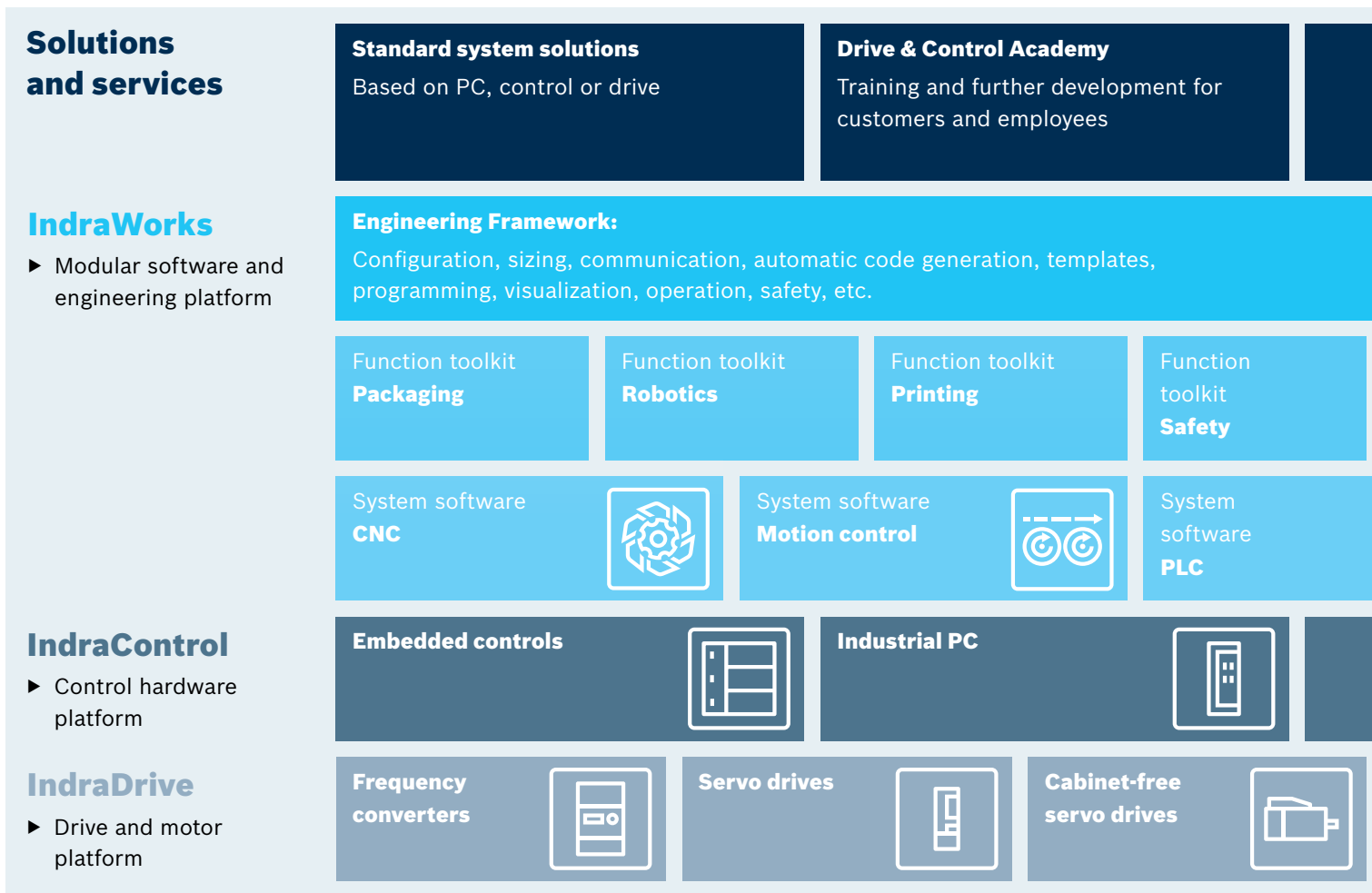

INDRAWORKS

The IndraWorks Engineering framework is the central software tool with which project planning, programming, commissioning and diagnosis of a wide variety of applications can be efficiently mapped over the entire product lifecycle of a machine.

Using function toolkits such as Packaging or Data Analytics, the standard PLC functionality of IndraWorks can be extended with technology-oriented solutions and adapted to individual needs. This accelerates the

implementation of complex machine processes, optimizes the project workflow in machine manufacturing through additional engineering interfaces or increases productivity through homogeneous integration of extended machine functionality.

INDRACONTROL

IndraControl is the hardware platform for control and visualization solutions and combines high functionality and maximum scalability. Thanks to the connection of further

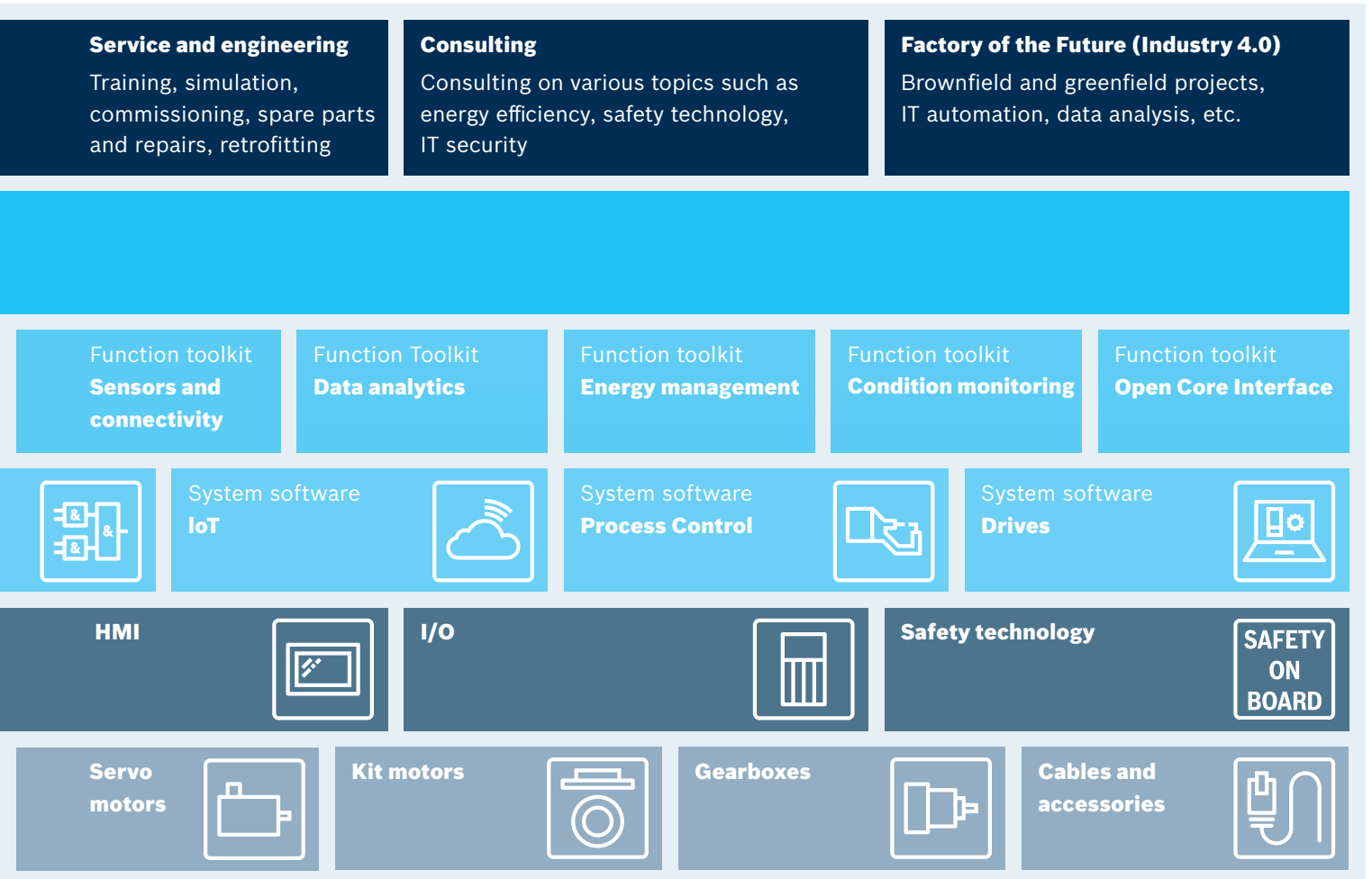

system solutions, the platform can be adapted easily to the individual requirements.

INDRADRIVE

The comprehensive motor portfolio from Bosch Rexroth convinces with the highest performance and a unique variety of designs, versions and performances. In combination with the IndraDrive drive system, both standard and high-end applications can be realized in modern factory automation with the robust motors –

intelligent, high-dynamic, precise and reliable. This is how machine manufacturers can meet the requirements of complex single- and multi-axis production systems and, at the same time, benefit from the flexibility and modularity of a state-of-the-art platform for the implementation of advanced drive-based automation strategies for distributed intelligence.



Tailor-made automation solutions



CNC

We offer the most powerful CNC in the market

Bosch Rexroth offers one of the most powerful and modern CNC platforms, which meets a wide range of requirements from the workshop to the networked production line in an Industry 4.0 environment. Due to the modular design of hardware and software, the CNC system can be optimally integrated into a wide variety of machine concepts. It opens up new horizons with comprehensive technology functions and outstanding power data.

At a glance:

- ▶ High-output milling, turning, grinding, punching, cutting, lasering, bending and additive manufacturing processes
- ▶ Up to 250 axes in 60 channels with one control
- ▶ Intuitive multi-touch operation
- ▶ Precise and reliable machining thanks to intelligent drive technology
- ▶ Open, decentralized system architecture and OPC UA



MOTION CONTROL

We are the pioneer in motion control

Based on the latest PLC technology with object-oriented language extensions for simplified modularization, the motion control system is the perfect basis for intelligent automation of production machinery and systems. Both fast I/O signal processing and high-dynamic motion control tasks can be realized in this way – up to 192 axes with only one control system.

What's more, by means of Open Core Engineering, the motion control system connects what have up to now been the separate worlds of PLC and IT automation. This combination enables an unprecedented degree of freedom, flexibility and efficiency in automation.

At a glance:

- ▶ Control system for integrated and modern machine automation
- ▶ Scaled platform with flexible expansion options for centralized and decentralized automation topologies
- ▶ Supports electric, hydraulic and hybrid drives
- ▶ Highly flexible motion control for linear and non-linear interpolation
- ▶ Free selection of programming tools and languages
- ▶ Synchronization of more than 1 000 drives – within microseconds and with nanometer precision
- ▶ Cross-platform performance and openness

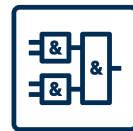

PLC & IOT

We bring the PLC to the Internet of Things

The IoT-capable PLC system from Bosch Rexroth is more than just processing and logic control, it has significantly more important information regarding the condition of machines and systems. The collected information is a reliable basis for the performance increase of systems – from assembly applications to building automation. The IoT Gateway makes it easier to connect existing and new systems. The IoT Gateway enables local storing and displaying of data and thus enables an increase in the OEE.

At a glance:

- ▶ Extensive experience as a leading user and provider of PLC and IoT solutions
- ▶ Free choice of programming languages for maximum flexibility in application
- ▶ IoT connectivity for new and existing machines
- ▶ Increase in machine availability through local database and flexible dashboard
- ▶ Hardware components for demanding industrial applications
- ▶ Universally applicable worldwide

OUR FORMULA FOR YOUR SUCCESS:

**Your machines and systems
+ intelligent system solutions
from Bosch Rexroth
= maximum performance for the
Factory of the Future**



PROCESS CONTROL

We are the world's market leader for welding control systems

With the Process Control welding control system, Bosch Rexroth provides a platform that meets the most demanding requirements and provides for intelligent current/voltage control to increase the process reliability, lower extra work costs and to deliver a consistent welding quality in production processes with high throughput. The platform also supports fast commissioning and is easy to operate.

At a glance:

- ▶ 80 % of automotive manufacturers worldwide trust in spot weld control systems from Bosch Rexroth
- ▶ Optimized programming, control and monitoring functions
- ▶ Fast commissioning and simple operation
- ▶ Adaptive control for all welding tasks
- ▶ Programming and operation in just one tool



DRIVES

We are the benchmark for innovative electric drive technology

The Bosch Rexroth portfolio offers solutions from watt to megawatt range, control types for frequency converter and servo applications, designs for cabinet-free and cabinet-integrated topologies. Factory automation specialists from the machine tool industry, packaging, printing, assembly, and handling industries benefit from the in-depth applications know-how of Bosch Rexroth's industry experts, thereby opening up numerous new opportunities for innovative machine concepts.

At a glance:

- ▶ Certified Safety on Board functions for maximum safety
- ▶ Power range from 100 W to 4 MW
- ▶ 100 % cabinet-free solutions can be realized
- ▶ Full IoT connectivity
- ▶ Unattainable freedom of communication and fast engineering
- ▶ Proven millions of times in machines and systems

AUTOMATION SOFTWARE

2

Automation software

18

MTX

20

- ▶ CNC system based on embedded control 20
- ▶ Operation Desktop 28
- ▶ Virtual Machine Simulation 30
- ▶ Virtual Machine Builder 31

MLC

32

- ▶ Motion control system based on embedded control and industrial PC 32

MLD

42

- ▶ Motion control system based on drive technology 42

MPC

48

- ▶ Precision motion control system based on embedded control YM 48

FTS

50

- ▶ Flexible Transport System based on embedded control YM 50

ILC

54

- ▶ IoT-enabled PLC system based on embedded control and industrial PC 54

IoT Gateway

60

- ▶ IoT system for new and existing machines 60

IoT Insights

64

- ▶ IoT system for greater transparency in manufacturing 64

Automation software

For the Factory of the Future, we offer the technically and economically optimal automation solution for every application. Whether it's for single-axis applications, PLC, motion control or CNC applications – the open and future-proof software portfolio ensures maximum productivity in modern factory automation. The application- and industry-specific system software solutions combine our control and drive platforms with integrated automation systems for maximum machine performance. Combined with our trendsetting IoT solutions, we enable machine builders and end-users to bridge between automation technology and the IT world – for maximum transparency in the application.

- ▶ **Open and scalable for individual applications in all industries**
- ▶ **Integrated automation software for all control and drive platforms**
- ▶ **Comprehensive technology functions for easy and fast engineering**
- ▶ **Certified safety functions for the effective protection of man and machine**
- ▶ **Maximum data security due to Bosch IT security standards**
- ▶ **Energy management for the highest energy efficiency**
- ▶ **Open Core Engineering for the perfect bridge of automation and the IT world**

MTX

▶ **MTX**

The CNC system for machining, forming and for additive manufacturing processes

MLD

▶ **MLD**

The drive-based motion control system for single-axis and synchronized multi-axis applications

MLC

▶ **MLC**

The motion control system for highly synchronous multi-axis applications with large number of axes, e.g. for printing, packaging, handling and robotic applications.

ILC

▶ **ILC**

The IoT-capable PLC system for factory and building automation applications



MPC

▶ MPC

The precision motion control system for the semiconductor, electronics and photovoltaic industry

IoT Gateway

▶ IoT Gateway

The solution for the acquisition and processing of all machine and production data

FTS

▶ FTS

The Flexible Transport System for fast and flexible material flows

IoT Insights

▶ IoT Insights

The solution for recording, processing and visualizing machine and production data

MTX

CNC system based on embedded control

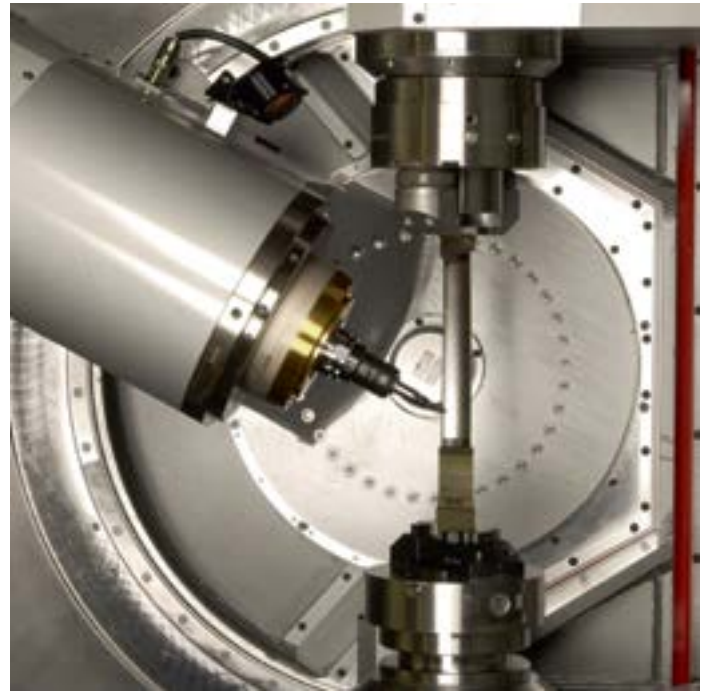

The combination of high-performance multi-core processors and responsive decentralized intelligence renders MTX the most powerful CNC in the market. With 60 independent CNC channels and 250 axes in only one control, the CNC system sets new standards. The modular design of hardware and software simplifies integration in different machine concepts. Already today, the MTX CNC system is ready for the Factory of the Future thanks to i4.0 communication according to the OPC UA standard.

Applications

MTX micro

- ▶ Turning
- ▶ Milling
- ▶ Drilling
- ▶ Grinding
- ▶ Gear machining

MTX

- ▶ Turning
- ▶ Milling
- ▶ Drilling
- ▶ Grinding
- ▶ Gear machining
- ▶ Bending (pipe, wire)
- ▶ Nibbling
- ▶ Punching
- ▶ Jet cutting (lasers, plasma, water, oxyfuel cutting)
- ▶ Handling
- ▶ Additive manufacturing processes (3D printing)

MTX micro

MTX micro is the compact, powerful and cost-effective CNC system for standard lathes and milling machines. It consists of a high-performance CNC and PLC, tailor-made operator panels and compact multi-axis control units.

- ▶ **Up to 12 axes**
- ▶ **Minimal machining times thanks to powerful 32-bit processor**
- ▶ **Ready-to-use software for turning and milling**
- ▶ **Extensive technology-cycle library and multi-technology functions for complete machining**
- ▶ **CNC-optimized operator panels and software**
- ▶ **Quick and easy commissioning of the turn-key system**
- ▶ **Open PLC according to IEC 61131-3 for application-specific extensions**
- ▶ **Low space requirements thanks to compact multi-axis control unit in control cabinet**
- ▶ **Direct connection to supply networks 200 ... 500 V, 50 ... 60 Hz without transformer**

MTX standard, performance, advanced

MTX is the individually scalable CNC system with integrated PLC for cutting, forming and additive manufacturing processes. Outstanding power data and extensive technology functions ensure high productivity and maximum flexibility. Regardless whether you control a standard machine or a fully automated production system – MTX provides for high-dynamic machining with minimized downtimes in every application.

- ▶ **Up to 250 axes**
- ▶ **Minimal PLC and CNC cycle times even for high-speed processing**
- ▶ **Innovative CNC core with extensive technology functions**
- ▶ **Individually scalable in power and function**
- ▶ **Flexibly configurable and intuitive operating interface and standard operating concept for easy programming**
- ▶ **Open system platform**

MTX

■ For more information, please visit: www.boschrexroth.com/cat-mtx

Technical specifications				
Type	MTX micro	MTX standard	MTX performance	MTX advanced
Machining technologies				
Turning	●	●	●	●
Milling	●	●	●	●
Drilling	●	●	●	●
Grinding	●	●	●	●
Nibbling, jet cutting	–	●	●	●
Reforming	–	●	●	●
Additive manufacturing processes	–	●	●	●
Axis control				
Default number of axes	3/4 ●	8 ●	8 ●	8 ●
Max. number of axes	12 ○	12 ○	64 ○	250 ○
Thereof max. number of screws	4 ●	4 ●	32 ○	60 ○
Default number of independent channels	2 ●	2 ●	3 ●	3 ●
Max. number of independent channels	2 ●	2 ●	12 ○	60 ○
Default number of interpolating axes per channel	4 ●	4 ●	4 ●	4 ●
Max. number of interpolating axes per channel	5 ○ ⁸⁾	5 ○ ⁸⁾	8 ○ ⁸⁾	8 ○ ⁸⁾
Linear axes	●	●	●	●
Rotary axes	●	●	●	●
Endlessly rotating rotary axis	●	●	●	●
Hirth axes	●	●	●	●
Screw/C-axis switchover	●	●	●	●
Max. number of gantry groups per channel	1 ●	4 ○ ^{2) 3) 5)}	8 ○ ^{2) 3) 5)}	8 ○ ^{2) 3) 5)}
Channel-independent axis transfer	●	●	●	●
Electronic cam	●	●	●	●
Electronic gear function of system axis coupling	●	○ ⁶⁾	○ ⁶⁾	○ ⁶⁾
Main spindle synchronization	●	○ ^{1) 2)}	○ ^{1) 2) 3)}	○ ^{1) 2) 3)}
Axis-specific jerk limitation	●	●	●	●
Interpolation functions				
Linear line interpolation with/without exact stop	●	●	●	●
Circular interpolation with radius and center programming, helical interpolation	●	●	●	●
Circular interpolation with tangential entry	●	●	●	●
Rigid tapping cycle	●	●	●	●
Thread cutting	●	●	●	●
Cylinder surface transformation	●	○ ^{1) 5)}	○ ^{1) 5)}	○ ^{1) 5)}
C-axis transformation	●	○ ¹⁾	○ ¹⁾	○ ¹⁾
System axis coupling for synchronizations	●	○ ⁶⁾	○ ⁶⁾	○ ⁶⁾

Technical specifications					
Type		MTX micro	MTX standard	MTX performance	MTX advanced
Interpolation functions					
NC block preview, look-ahead		max. 1 000 blocks	max. 1 000 blocks	max. 1 000 blocks	max. 1 000 blocks
5-axis transformation with TCP programming		○ ⁸⁾	○ ^{3) 8)}	○ ^{3) 8)}	○ ^{3) 8)}
Jogging with active transformation		●	○ ³⁾	○ ³⁾	○ ³⁾
Spline interpolation C1 + C2 continuous, cubic splines B-splines, NURBS		●	○ ^{1) 2) 3) 5)}	○ ^{1) 2) 3) 5)}	○ ^{1) 2) 3) 5)}
Nanometer resolution		●	●	●	●
Feed functions					
Feedrate per revolution		●	●	●	●
Constant cutting speed		●	○ ¹⁾	○ ¹⁾	○ ¹⁾
Travel to fixed stop		●	●	●	●
Torque reduction		●	●	●	●
Shifts and compensations					
Mirroring, scaling, rotating		●	●	●	●
Zero point offset		●	●	●	●
Compensations and zero offsets programmable through CPL		●	●	●	●
Placements (frames)		●	○ ^{2) 3)}	○ ^{2) 3)}	○ ^{2) 3)}
2D path compensation		●	●	●	●
3D cutter radius compensation		–	○ ³⁾	○ ³⁾	○ ³⁾
Compensation with plane switching		●	●	●	●
Tangential tool guidance		●	●	●	●
Tool management					
Integrated, flexible tool management		●	●	●	●
Configurable tool database		●	●	●	●
Freely definable tool corrections (length, radius, edge position, user data)		●	●	●	●
Additive tool corrections (D corrections)		●	●	●	●
Access to tool data from the PLC		●	●	●	●
Access to tool data from the CNC		●	●	●	●
CNC programming					
Parts program development (DIN ISO 66025, RS 274)		●	●	●	●
High-level language programming, CPL (Customer Programming Language)		●	●	●	●
Macro programming		●	●	●	●
2D contour plot, isometric		●	–	–	–
3D machine simulation		–	○ ⁴⁾	○ ⁴⁾	○ ⁴⁾
CNC RAM	MB	64	256	1 024	1 024
Static memory	MB	4	8	16	16
Max. parts program size	MB	8	Unlimited (PC hard disk, network file system)		
Removable medium (CF/MicroSD data memory)		●	●	●	●

● Standard ○ Option

¹⁾ Technology package – Turning 1

²⁾ Technology package – Milling 1

³⁾ Technology package – Milling 2

⁴⁾ Technology package – CNC simulation “Virtual machine”

⁵⁾ Technology package – Jet cutting

⁶⁾ Technology package – Electronic gear

⁷⁾ Option with IndraDrive

⁸⁾ Option subject to export approval according to Part I C of the Export List (EC Regulation) position 2D002

MTX

■ For more information, please visit: www.boschrexroth.com/cat-mtx

Technical specifications					
Type		MTX micro	MTX standard	MTX performance	MTX advanced
Technology cycles					
Turning		●	●	●	●
Milling		●	●	●	●
Drilling		●	●	●	●
Functions					
Acceleration programming, loop gain programming		●	●	●	●
Homing through NC program		●	●	●	●
Absolute dimension, relative dimension		●	●	●	●
Switching between inch and mm		●	●	●	●
Probe, static/on-the-fly measurement		●	●	●	●
Read process and drive data through Sercos		●	●	●	●
Roundings and chamfers		●	●	●	●
Corner rounding with splines		●	●	●	●
Laser power control		●	●	●	●
Automatic distance control for jet cutting		–	○ ⁵⁾	○ ⁵⁾	○ ⁵⁾
Leap-Frog – positioning for jet cutting		–	○ ⁵⁾	○ ⁵⁾	○ ⁵⁾
Fly-cut for jet cutting		–	○ ⁵⁾	○ ⁵⁾	○ ⁵⁾
Digitizing		●	●	●	●
NC block defined by PLC		●	●	●	●
Support for control elements					
NC program restart/block search		●	●	●	●
Dry run		●	●	●	●
Retracting from and returning to the contour		●	●	●	●
Retrace function: reversing over the contour		–	○ ⁵⁾	○ ⁵⁾	○ ⁵⁾
PLC programming					
Integrated PLC: ILC		●	●	●	●
Programming languages IEC 61131-3 (IL, LD, FUP, ST, SFC, CFC)		●	●	●	●
PLC program memory	MB	2	16	16	16
High-speed inputs/outputs		8/8 ●	S20 local I/O	S20 local I/O	S20 local I/O
Number of fieldbus inputs/outputs	Byte	8 192/8 192	8 192/8 192	8 192/8 192	8 192/8 192
Multitasking		●	●	●	●
Max. number of PLC tasks		2	8	8	8
Fast actions (fast PLC task)		–	○	○	○

Technical specifications					
Type		MTX micro	MTX standard	MTX performance	MTX advanced
Diagnostic and commissioning tools					
IndraWorks Engineering		○	○	○	○
Instructions and error messages in plain text		●	●	●	●
Integrated drive configuration		●	●	●	●
Drive oscilloscope		○	●	●	●
Integrated PLC project configuration		○	●	●	●
Logic analyzer		○	●	●	●
Circular shape test		○	●	●	●
NC analyzer		–	●	●	●
Action recorder MTX acr		–	○	○	○
Cycle time analysis MTX cta		○	○	○	○
Energy analysis MTX ega		○	○	○	○
Training program MTX micro trainer		●	–	–	–
Open architecture					
Configurable operator interface		–	●	●	●
User-specific operator screens		–	●	●	●
Adaptation and integration via standardized interfaces (OPC UA, XML, ActiveX, .NET)		–	●	●	●
Control hardware and communication interfaces					
CPU (see also IndraDrive HCT/HCQ or XM42)		HCT/HCQ	XM42	XM42	XM42
Sercos	On-board	●	●	●	●
PROFINET I/O	On-board	–	○	○	○
EtherNet/IP	On-board	–	○	○	○
Ethernet TCP/IP	On-board	●	●	●	●
PROFIBUS	Extension modules	–	○	○	○
Automation protocols					
OPC UA server/client		●	○	●	●
Safety technology					
SafeMotion – Integrated safety technology compliant with EN ISO 13849-1 cat. 3 PL e or EN 62061 SIL 2		–	○ ⁷⁾	○ ⁷⁾	○ ⁷⁾
SafeLogic	Extension modules	–	○	○	○
SafeLogic compact	Self-sustaining safety control	○	○	○	○

● Standard ○ Option

¹⁾ Technology package – Turning 1

²⁾ Technology package – Milling 1

³⁾ Technology package – Milling 2

⁴⁾ Technology package – CNC simulation “Virtual machine”

⁵⁾ Technology package – Jet cutting

⁶⁾ Technology package – Electronic gear

⁷⁾ Option with IndraDrive

⁸⁾ Option subject to export approval according to Part I C of the Export List (EC Regulation) position 2D002

MTX

■ For more information, please visit: www.boschrexroth.com/cat-mtx

Suitable products for MTX			
Engineering			Page
Engineering software		IndraWorks Engineering	374 ff.
HMI interface		MTX Operation Desktop	28 f.
Machine simulation		MTX Virtual Machine Simulation	30
Kinematic model generation		MTX Virtual Machine Builder	31
Control components			
Embedded control		XM42	100 f.
Drive-integrated control system (MTX micro)		HCT02, HCQ02	240 f.
Visualization and operation			
Industrial PC and HMI	Box PC	PR21, PR31, PR4, VPB40.4	74 ff.
	Display	DR, VDP81, VDP82	80 ff.
	Compact operator panels	VR21	84 f.
	Panel PC	VR31, VR4	86 ff.
	Machine operator panels	VAM15, VAM21, VAM81, VAM82	90 ff.
System periphery			
I/O systems	IP20	S20	118 ff.
	IP67	S67E	158 ff.
Drive components			
Frequency converters		EFC3610, EFC5610	198 ff.
Servo drives	IndraDrive Mi	KSM02, KMS02, KMS03, KCU02, KMV03, KNK03, KLC03	216 ff.
	IndraDrive Cs	HCS01	232 ff.
	IndraDrive C	HCS02, HCS03, HCT02, HCQ02	236 ff.
	IndraDrive M	HMV01, HMS01, HMD01, HMV02, HMS02	242 ff.
	IndraDrive ML	HMU05	256 ff.
Servo motors and planetary gearboxes		MS2N, MS2E, MKE, MSM, MAD, MAF, GTE, GTM	290 ff.
Kit motors		MCL, ML3, MLF, MBT, MBS, 1MB	338 ff.



MTX

Operation Desktop



MTX Operation Desktop is the standardized operating interface for the operation and programming of CNC machines. Pre-defined standard screens make it possible to realize machine visualization efficiently. The basic functions included in the scope of delivery such as diagnostics, operating areas, header and user manager can be easily extended for specific applications. IndraWorks Engineering offers easy handling and optimal support via dialogs and high-performance tools, e.g. WinStudio.

- ▶ **Ready-made operating interface, including header, operating areas, user manager and much more**
- ▶ **Easy HMI configuration for easy operation of the system**
- ▶ **Application-specific upgradeability via dialog-supported project planning in IndraWorks Engineering**
- ▶ **Integration of customer-specific applications such as ActiveX or .NET Controls**
- ▶ **Simple integration of 3rd party software**
- ▶ **Consistent data storage – PLC, motion and HMI in one project**
- ▶ **Integrated diagnostics for control and drive messages**
- ▶ **HMI user interface localization using language modules**
- ▶ **Integrated machine and machining simulation**

■ For more information, please visit: www.boschrexroth.com/cat-iworks-o

Technical specifications		
Basic functions		
WinStudio	Scope of functions of the Lite license (500 tags)	●
	Optional function and variable expansion from 1.5 to 512 k tags	○
Operating system support	Windows 7	●
	Windows 10	●
General operating area concept	Ready-made navigation bars (OP/F/M panels)	●
	Header display: System status, diagnostic messages, PLC status, etc.	●
	Pre-defined operating images for manual movement of axes with position, status, and feasibility display	●
	ACI images (configurable screens for the display of pre-defined and customer-specific ActiveX and .NET Controls)	●
Pre-defined operating areas	Display customized HMI images (WinStudio)	●
	Maintenance and diagnostics	●
	Preparing (machine-specific operating images)	●
	Machine (axis position, override for feed system/spindle, G-code, etc.)	●
	Program (CNC program editor, program selection)	●
	Tool management (tool identification, idling time management, correction value calculation, type definition)	●
	System (channel display and channel changing)	●
Production data	●	
Localization		
Standard languages	Chinese, German, English, French, Italian, Swedish, Spanish	●
Optional language modules	HMI interface texts	○
	CNC messages and diagnoses	○
Diagnosis		
Diagnostic systems	ProVi (PLC-based message system)	●
	MZA (machine error and status display)	●
	CNC messages and diagnoses	●
Header message line	Display of active messages of the classes: Warning, error, information	●
Operating area diagnosis	Detailed list of all accumulated errors by date/time	●
	Additional information on cause and rectification (text or HTML)	●
	Filter by message class	●
Logbook	Logging of all message classes according to the time: Warning/error/information/setup diagnostics/start conditions	●
	Filter by: Time window, source, message class and text	●
	Export function in formats: ASCII, CSV, XML	●
Fieldbus diagnostics	PROFIBUS	●
	Overview and presentation of individual bus users	●
Criteria analysis for step chains	Automatic display of the step chain name and program instruction at the time of the error	●
Options		
Technology packages	Virtual Machine Simulation	○

● Standard ○ Option ▼ In preparation

MTX

Virtual Machine Simulation



As standard, the CNC system MTX contains a simple CNC machining simulation considering the relative movements of the tool and the work piece. For the simulation of complete machine tools, the MTX software option “Virtual Machine Simulation” is available. The machine model contains kinematic relations (axes) as well as 3D geometries of the machine, the equipment, the work pieces and the tools. The combination with the virtual MTX and the integration of the 3D window into the original MTX operating interface creates a digital twin of the machine. In addition to the scope of functions of the MTX, the usual simulation functions such as machine movements with representation of the tool path, material application/removal and collision detection are also available. The optional “Virtual Machine Builder” is necessary for the setup of the required kinematics models.

- ▶ **Machining simulation of machine tools**
- ▶ **3D visualization of machine movements, material application/removal and collisions**
- ▶ **Realistic simulation thanks to the integration of a virtual MTX**
- ▶ **Supported technologies: Drilling, milling, punching/nibbling, jet cutting, additive manufacturing processes (3D printing)**

■ For more information, please visit: www.boschrexroth.com/cat-vms

Technical specifications	
Type	Virtual Machine Simulation
3D simulation of machine tools in connection with a virtual MTX	●
Visualization of the machine movements incl. tool path	●
Calculation and illustration of the material application or removal	●
Automatic collision detection	●
IndraWorks software option	●
Integrated in MTX Operation Desktop	●

● Standard ○ Option ▼ In preparation

MTX

Virtual Machine Builder



The CNC system MTX offers you the possibility of a 3D simulation for machine tools (Virtual Machine Simulation). The kinematic models required for this can be set up with the “Virtual Machine Builder”. This is an intuitively usable tool to define linear/rotatory axes, their parameters and structural elements for work pieces/tools. The model is completed via the import of 3D geometry data in STL format as well as the definition of collision relations. The “Virtual Machine Builder” is a stand-alone software which, for example, can be used independently of IndraWorks in the construction department.

- ▶ **Setup and customization of kinematics for the Virtual Machine Simulation of the MTX**
- ▶ **Definition of kinematic relations**
- ▶ **Import and adaptation of 3D geometry data (format: STL)**
- ▶ **Definition of collision relations**

■ For more information, please visit: www.boschrexroth.com/cat-vmb

Technical specifications

Type	Virtual Machine Builder
Graphic interface for the setup and parameterization of kinematics models	●
Import of 3D geometries in STL format	●
3D visualization of the machine geometry	●
Interactive movement of the machine model	●
Definition of collision groups	●
Can be used independently of IndraWorks (stand-alone application)	●

● Standard ○ Option ▼ In preparation

MLC

Motion control system based on embedded control and industrial PC



The MLC motion control system is the complete control system – from simple cartesian handling tasks to complex robot applications and high-dynamic machines for the packaging and printing industry as well as for multi-axis applications with requirements for coordinated movements and synchronicity, with medium to large number of axes. MLC function packages are optimally scalable to the respective requirements – from price-optimized solutions based on the XM21 embedded control with a maximum of eight axes and kinematics for compact machines to high-end applications with up to 192 synchronous axes based on the XM42 embedded control.

In addition, the MLC motion control system is also available as an IPC-based high-end solution for demanding visualization and engineering tasks. For maximum performance and availability, the real-time control functions are decoupled from the Windows operating system.

Another advantage: The template-based engineering facilitates programming significantly and therefore enables fast time-to-market cycles.

Applications

- ▶ Automotive industry
- ▶ Packaging machines
- ▶ Printing machines
- ▶ Assembly and handling
- ▶ Plastic and die-casting machines
- ▶ Wood working machines
- ▶ Glass machining machines
- ▶ Semiconductors and electronics
- ▶ Solar industry
- ▶ Forming machine tools and press lines

MLC – based on XM embedded control system

The family of the compact control platform IndraControl XM offers the latest hardware technology in a robust enclosure design. It combines the excellent real-time capability of the Sercos automation bus and the flexibility and high performance of the S20 I/O series to create a modular and complete automation system.

- ▶ **SERCOS on-board, PROFINET IO, EtherNet/IP, PROFIBUS and Multi-Ethernet optional**
- ▶ **Easy functionality extension thanks to extension modules (communication, technology)**
- ▶ **Simple I/O integration through S20 I/O modules that can be directly connected in series or through integration of decentralized I/O stations via different fieldbuses**
- ▶ **Fast I/O process data processing in different operation modes (asynchronous, cycle-synchronous, cyclic)**
- ▶ **Shortest PLC cycle times of 250 µs**
- ▶ **Up to 192 axes with synchronized and coordinated movements on one control**

MLC – based on industrial PC VPB

Based on VPB40, MLC offers a powerful and flexible industrial PC control solution. In addition to the motion control application, high-performance software tools for visualization, process data processing, analysis or reporting can be operated on the same control hardware. A subordinate hypervisor distributes the hardware resources to the real-time-capable motion control system MLC and the open operating system Windows 7/10. MLC thus offers even more performance and flexibility – for maximum efficiency in all applications.

- ▶ **Complete control system with fast process data processing and maximum motion control performance**
- ▶ **Windows 7/10 and motion control firmware on one hardware**
- ▶ **Modular expansion options with PCIe plug-in card**

MLC

Overview											
Level	Entry			Mid range			High end				
Hardware type	Embedded control								Industrial PC		
Control system	XM21			XM22			XM42			VPB40.4 (4 slots)	
Function packages	Motion robotics										
Scaling	Basic	Standard	Basic	Standard	Basic	Standard	Advanced	Basic	Standard	Advanced	
Axes	8	20	16	40	64	128	192	64	128	192	
Control axes	8	16	16	16	99	99	99	99	99	99	
Kinematics	1	2	4	16	16	24	32	16	24	32	
Extension modules	3	3	3	3	3	3	3	3	3	3	
Motion cycle time	ms	2	2	1	1	0.25	0.25	0.25	0.25	0.25	0.25
Sercos cycle time	ms	1	1	0.25	0.25	0.25	0.25	0.25	0.25	0.25	0.25

■ For more information, please visit: www.boschrexroth.com/cat-mlc

Technical specifications						
Type			XM21	XM22	XM42	VPB40.4
Runtime system	Integrated motion control system		●	●	●	●
Multitasking			●	●	●	●
Data management	Code, data, remanent data, user data		●	●	●	●
Saving	Boot project		●	●	●	●
	PLC project as packed archive file		●	●	●	●
	User data in the internal memory and removable memory		●	●	●	●
Support	Extension modules		3	3	3	4 (PCIe)
	System events		●	●	●	●
User memory	Total: code, data	MB	36	36	1 024	64
Remanent memory	Total: system, user	kB	128	128	4 096	2 048
Processor	Intel		Atom	Atom	Core i3	Core i7
Total memory		GB	0.5	0.5	2	16
Operating system			Wind River Systems VxWorks	Wind River Systems VxWorks	Wind River Systems VxWorks	Wind River Systems VxWorks and Microsoft Windows 7/10, hypervisor mode

Technical specifications						
Type		XM21	XM22	XM42	VPB40.4	
On-board diagnostics and settings						
Status display (boot, Sercos, test)	LED (XM) or System Tray Application (VPB40.4)	●	●	●	●	
Errors, warnings, messages, system reset	LED (XM) or System Tray Application (VPB40.4)	●	●	●	●	
Ethernet settings (IP address)	First Touch and WebAssistant	●	●	●	●	
Voltage monitoring, watchdog	LED	●	●	●	●	
On-board communication interfaces						
Sercos	Automation bus	●	●	●	● (PCIe)	
Master axis link	Sercos	○	○	○	–	
	Number of controls in the group	64	64	64	–	
PROFINET IO	Controller (master)	–	–	○	–	
	Device (slave)	–	–	○	–	
EtherNet/IP	Scanner (master)	–	–	○	–	
	Adapter (slave)	–	–	○	–	
Ethernet TCP/IP		●	●	●	●	
Control link	Ethernet TCP/UDP/IP	●	●	●	●	
USB host/device	On-board	●/●	●/●	●/●	●/–	
External service monitor	DP	–	–	–	●	
Serial	1 x CDI interface – connection of industrial PC to display/terminal	–	–	–	●	
Automation protocols						
OPC UA	Server/client	○/○	○/○	○/○	○/○	
Extension modules						
Number		3	3	3	4 (PCIe)	
PROFIBUS master/slave		○	○	○	○	
PROFINET controller/device		○	○	○	○	
EtherNet/IP scanner/adapter		○	○	○	○	
Sercos/master axis link		○	○	○	–	
SafeLogic	Safety control according to IEC 61508 (SIL 3) and EN ISO 13849-1 (PL e/Cat 4)	○	○	○	○	
HMI						
VR, PR/DR	Ethernet TCP/IP, OPC UA	○	○	○	○	
Input/output						
Can be added locally to control system						
S20 (digital, analog, relay, technology, communication, safety)	64 byte, max. 63 I/O	○	○	○	–	
Decentralized via S20 bus coupler (IP20)						
Sercos	On-board	○	○	○	○ (PCIe)	
PROFIBUS	Extension module	○	○	○	○ (PCIe)	
EtherNet/IP	Extension module/on-board	○/–	○/–	○/○	○ (PCIe)	
PROFINET	Extension module/on-board	○/–	○/–	○/○	○ (PCIe)	
Decentralized via S67E bus coupler (IP67)						
Sercos	On-board	○	○	○	○	
PROFINET	On-board	○	○	○	○	

● Standard ○ Option ▼ In preparation

MLC

■ For more information, please visit: www.boschrexroth.com/cat-mlc

Technical specifications						
Type			XM21	XM22	XM42	VPB40.4
Logic Control						
PLC runtime system						
Logic 2G kernel	As per IEC 61131-3 with addition		●	●	●	●
Program organization	As per IEC 61131-3		●	●	●	●
Loading and execution of the IEC 61131-3 applications			●	●	●	●
Task management						
Freely configurable tasks (priority 0-20)	Cyclic, free-running, event-controlled, externally event-controlled		20	20	20	20
Processing of the I/O process image	Cycle-synchronous		●	●	●	●
	Clock-synchronous		●	●	●	●
	Sercos-synchronous		●	●	●	●
PLC cycle time	Synchronous to the system cycle	ms	≥ 1	≥ 1	≥ 1	≥ 1
	Synchronous to the Sercos cycle	ms	≥ 1	≥ 0.25	≥ 0.25	≥ 0.25
Motion cycle time	Command value generator	ms	≥ 2	≥ 1	≥ 0.25 ¹⁾	≥ 0.5
PLC processing times						
Typical processing time for 1 000 instructions	Command mix (real, integer, Boolean, etc.)	μs	26	13	2	2
	Boolean operations	μs	5	5	4	4
	Word operations	μs	5	5	1	1
Motion control						
Standard functions						
Number of axes	Real, virtual, encoder, group		40	40	192	99
Controller axis	Centrally controlled		16	16	99	64
Synchronization (ELS – Electronic Line Shaft)	Real axes (servo drives)		●	●	●	●
	Virtual axes (virtual masters)		●	●	●	●
	Encoder axes (real masters)		●	●	●	●
	Grouped axes (cross communication)		●	●	●	●
	Dynamic synchronization		●	●	●	●
	Master axis cascading		●	●	●	●
Positioning	Single axis		●	●	●	●
Electronic gears			●	●	●	●
Electronic cams	Support point tables (drive-internally, max. 1 024 support points)		4	4	4	4
	Electronic motion profile (control-internal, motion profiles with max. 16 segments)		2	2	2	2
	FlexProfile (control-internal, master/time-based motion profiles with max. 16 segments)		4	4	4	4

Technical specifications						
Type		XM21	XM22	XM42	VPB40.4	
Motion control						
Standard functions						
Motion commands according to PLCopen (selection)	MC_MoveAbsolute		●	●	●	●
	MC_MoveRelative		●	●	●	●
	MC_MoveVelocity		●	●	●	●
	MC_Home		●	●	●	●
	MC_CamIn, MC_CamOut		●	●	●	●
	MC_GearIn, MC_GearOut		●	●	●	●
Extended motion commands (selection)	MB_ReadListParameter		●	●	●	●
	MB_WriteListParameter		●	●	●	●
	MB_GearInPos		●	●	●	●
	MB_PhasingSlave		●	●	●	●
	MB_ClearAxisError		●	●	●	●
	MB_ClearSystemError		●	●	●	●
Hydraulic-specific functions						
Function			The "Hydraulics" function toolkit supports the seamless integration of electro-hydraulic axes into the MLC automation software. This enables centralized or decentralized control in accordance with the PLC standard IEC 61131-3. An extended command set for the Structured Text (ST) language allows for easy programming of sequential procedures, particularly in combination with the Generic Application Template (GAT) function toolkit. Individual control models and simulation data can be easily integrated via software interfaces.			
Multi axis controller (best-in-class)			●	●	●	●
Synchronizer			●	●	●	●
Alternating control			●	●	●	●
Force ramps/curves			●	●	●	●
Travel-dependent deceleration			●	●	●	●
Sytronix controller	Variable-speed pump systems		●	●	●	●
Sequential programming in ST code			●	●	●	●
Hydraulic-specific template (GAT)			●	●	●	●
Drive systems						
Electric axes						
IndraDrive C, M, ML	Single-axis control units with firmware MPB/MPC		●	●	●	●
IndraDrive M	Double-axis control units with firmware MPM		●	●	●	●
IndraDrive Mi	With firmware MPB		●	●	●	●
IndraDrive Cs	With firmware MPB/MPC		●	●	●	●
Sercos pack profiles			●	●	●	●
Master communication	Sercos		●	●	●	●
Sercos cycle time		ms	≥ 1	≥ 0.25	≥ 0.25	≥ 0.25
Hydraulic axes						
VT-HMC-1-1x (Sercos)	Decentralized axis control (IP20)		●	●	●	●
IAC Multi-Ethernet	Valve-integrated axis control (decentralized)		●	●	●	●
S20 I/O system (S20-AI6-AO2-SSI2)	Control-integrated axis control (central)		●	●	●	●

● Standard ○ Option ▼ In preparation

¹⁾ Depending on the application

MLC

■ For more information, please visit: www.boschrexroth.com/cat-mlc

Technical specifications					
Type	XM21	XM22	XM42	VPB40.4	
Motion control					
Hybrid axes (variable-speed pump systems)					
Sytronix FcP	●	●	●	●	
Sytronix DFEn	●	●	●	●	
Sytronix SvP	●	●	●	●	
Robot Control					
Function	The "Robot Control" function toolkit offers a large number of pre-defined kinematics, transformations and extensive function libraries for the automation of standardized robots. Configuration and parameterization dialogs help with setup and reduce programming effort. PLCopen, the kinematics interface and Open Core Interface for high-level language programming provide the user with full flexibility in application development. Using the scripting language Lua allows complex robot movements, which can be individually adapted with simple tools, e.g. a text editor.				
Number of axes per kinematic	16	16	16	16	
Multi-axis kinematics	Incl. Auxiliary axes	2	16	32	16
Kinematic transformations	●	●	●	●	
Interpolation types LINEAR, CIRCULAR, PTP	●	●	●	●	
Configurable block transitions	●	●	●	●	
Override	●	●	●	●	
Teach-in function	●	●	●	●	
Movements with blendings in the room	●	●	●	●	
Late Bending (late movements with blendings)	●	●	●	●	
Belt synchronization	●	●	●	●	
Jogging/single-step	●	●	●	●	
Speed limit	For path and axes	●	●	●	●
Acceleration limit	For path and axes	●	●	●	●
Protection zones	●	●	●	●	
Expanded system functions (selection)					
Programmable limit switch	●	●	●	●	
Measuring wheel	●	●	●	●	
Measuring probe	●	●	●	●	
Technology functions (selection)					
Function	The "Technology" function toolkit provides ready-to-use PLC function modules for implementation of process-oriented functions for a wide range of applications. All components are based on the IEC 61131-3 and PLCopen PLC standards and are provided in the form of comprehensive function libraries. More complex functions allow for easy adjustment and parameterization via wizards.				

Technical specifications					
Type		XM21	XM22	XM42	VPB40.4
Technology functions (selection)					
Crank kinematics		●	●	●	●
Cross cutters		●	●	●	●
Flying shear		●	●	●	●
Loop control		●	●	●	●
Tension control		●	●	●	●
Register control		●	●	●	●
Winder		●	●	●	●
Magic Belt		●	●	●	●
Smart Belt		●	●	●	●
Diagnosis					
Diagnosis (status, warning, error)	Function modules (software)		●	●	●
	Parameter access diagnostic memory (software)		●	●	●
	Local via status display (control hardware)		●	●	●
	Axis monitoring (e.g. power, encoder, limit values)		●	●	●
	Diagnostics memory (64 kB, max. 999 messages)		●	●	●
Debugging monitor for IEC applications			●	●	●
Engineering and operation					
IndraWorks	Engineering tool		○	○	○
First Touch	Web-based commissioning		●	●	●
WebAssistant (web-based engineering)					
Function		The WebAssistant is a web-based operating interface for maintenance, service and diagnosis of MLC/ILC automation systems. The webpages are located directly on the control and can be accessed very easily by means of a standard browser. The WebAssistant is automatically adjusted to the resolution of the browser. The operating interface optimized for touch operation can be customized with the help of the WebComposer.			
Pre-defined web interface			●	●	●
Can be expanded customer-specifically	Using IndraWorks WebComposer		○	○	○
Integrated web server on the control system	Visualization via a standard web browser		●	●	●
Underlying web technologies	HTML5		●	●	●
	JavaScript		●	●	●

● Standard ○ Option ▼ In preparation

MLC

■ For more information, please visit: www.boschrexroth.com/cat-mlc

Suitable products for MLC			
Engineering			Page
Engineering software		IndraWorks Engineering	374 ff.
Control components			
Embedded control		XM21, XM22	98 f.
		XM42	100 f.
Industrial PC control	Box PC	VPB40.4	78 f.
Visualization and operation			
Industrial PC and HMI	Box PC	PR21, PR31, PR4, VPB40.4	74 ff.
	Display	DR	80 f.
	Compact operator panels	VR21	84 f.
	Panel PC	VR31, VR4	86 ff.
	Machine operator panels	VAM15, VAM21	90 ff.
System periphery			
I/O systems	IP20	S20	118 ff.
	IP67	S67E	158 ff.
Drive components			
Frequency converters		EFC3610, EFC5610	198 ff.
Servo drives	IndraDrive Mi	KSM02, KMS02, KMS03, KCU02, KMV03, KNK03, KLC03	216 ff.
	IndraDrive Cs	HCS01	232 ff.
	IndraDrive C	HCS02, HCS03	236 ff.
	IndraDrive M	HMV01, HMS01, HMD01, HMV02, HMS02	242 ff.
	IndraDrive ML	HMU05	256 ff.
Servo motors and planetary gearboxes		MS2N, MS2E, MKE, MSM, MAD, MAF, GTE, GTM	290 ff.
Kit motors		MCL, ML3, MLF, MBT, MBS, 1MB	338 ff.



1010101010001110101010 1100000111100110101010101010101010101010101

01011101010101001

716735877321732851145472583782317694794723718728737858736971387215873573251867848/

MLD

Motion control system based on drive technology

MLD

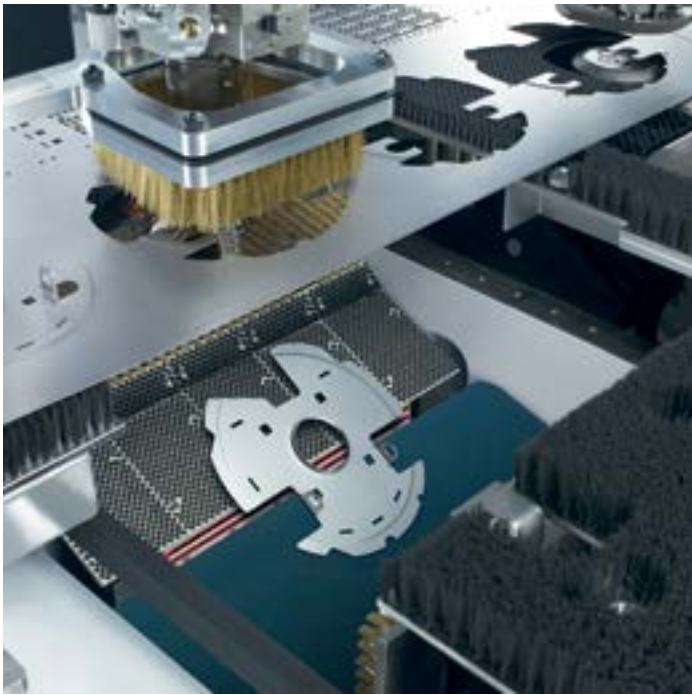

With MLD, motion and PLC functions merge to form a modern, open automation platform for modular machine concepts. The distributed control architecture forms a compact motion control system based on the scalable IndraDrive platform and makes higher-level controls superfluous. This drive-based solution is available as a single-axis control for simple applications and as a multi-axis control for applications with a maximum of 10 axes. Ready-to-use function libraries simplify the use of the intelligent drive functions of our IndraDrive drives. Components based on PLCopen also provide access to standardized motion control functions. Open technology and communication interfaces simplify the integration of MLD into any automation concept.

- ▶ **Drive-integrated motion control according to IEC 61131-3**
- ▶ **Electronic synchronization of up to 10 servo-axes**
- ▶ **Intuitive engineering using the IndraWorks software framework**
- ▶ **Optional technology and communication interfaces**
- ▶ **Certified safety technology**

Applications

- ▶ General automation technology
- ▶ Print and processing machines
- ▶ Conveying and warehousing systems
- ▶ Assembly and handling
- ▶ Wood working machines
- ▶ Plastics machines
- ▶ Food and packaging machines
- ▶ Forming machines

■ For more information, please visit: www.boschrexroth.com/cat-ml

Technical specifications									
Type		MLD-S ¹⁾ IndraDrive Mi	MLD-S ¹⁾ IndraDrive Cs	MLD-M ²⁾ IndraDrive Cs	MLD-S ¹⁾ IndraDrive C/M	MLD-M ²⁾ IndraDrive C/M	MLD-S ¹⁾ IndraDrive ML	MLD-M ²⁾ IndraDrive ML	
Control system									
Runtime system	Integrated motion control system	●	●	●	●	●	●	●	●
Multitasking		●	●	●	●	●	●	●	●
Data management	Code, data, remanent data, user data	●	●	●	●	●	●	●	●
Saving	Boot project	●	●	●	●	●	●	●	●
	PLC project as packed archive file	●	●	●	●	●	●	●	●
	User data in the internal memory and removable memory	●	●	●	●	●	●	●	●
Support	System events	●	●	●	●	●	●	●	●
Probe function control		○	○	○	○	○	○	○	○
User memory	Total: code, data	MB	0.5	0.5	4	0.5	4	0.5	4
Remanent memory	Total: system, user	kB	32	32	32	32	32	32	32
On-board diagnostics and settings									
Status display (boot, Sercos, test)	Display	–	●	●	●	●	●	●	●
Errors, warnings, messages, system reset	Display, keys	–	●	●	●	●	●	●	●
Ethernet settings (IP address)	Display, keys	–	●	●	●	●	●	●	●
Voltage monitoring, watchdog		●	●	●	●	●	●	●	●
Relay output ready for operation		●	●	●	●	●	●	●	●
IDST service tool		●	●	●	●	●	●	●	●
On-board communication interfaces									
Sercos	Automation bus (master/slave)	○/●	○/○	●/○	○/○	●/○	○/○	○/○	●/○
Multi-Ethernet		●	●	●	○	●	●	●	●
PROFIBUS	Slave	○	○	○	○	○	○	○	○
PROFINET IO	Device (slave)	○	○	○	○	○	○	○	○
EtherNet/IP	Adapter (slave)	○	○	○	○	○	○	○	○
Modbus TCP	Server (slave)	○	○	○	○	○	○	○	○
EtherCAT	Slave	○	○	○	○	○	○	○	○
Ethernet TCP/IP		●	●	●	●	●	●	●	●
Options									
Encoder	Number	≤ 2	≤ 2	≤ 2	≤ 2	≤ 2	≤ 2	≤ 2	≤ 2
Encoder emulation	Number	–	≤ 1	–	≤ 1	–	≤ 1	–	–
HMI									
VR21	Ethernet TCP/IP	○	○	○	○	○	○	○	○

● Standard ○ Option ▼ In preparation

¹⁾ Drive-based single-axis motion control system (BASIC control unit CSB)

²⁾ Drive-based multi-axis motion control system (ADVANCED control unit CSH)

MLD

■ For more information, please visit: www.boschrexroth.com/cat-mld

Technical specifications									
Type		MLD-S ¹⁾ IndraDrive Mi	MLD-S ¹⁾ IndraDrive Cs	MLD-M ²⁾ IndraDrive Cs	MLD-S ¹⁾ IndraDrive C/M	MLD-M ²⁾ IndraDrive C/M	MLD-S ¹⁾ IndraDrive ML	MLD-M ²⁾ IndraDrive ML	
Input/output									
On-board									
Digital inputs (total)	Number	7	≥ 7	≥ 7	≥ 7	11	≥ 7	11	
Digital inputs/outputs (can be set as required)	Number	1	≥ 1	≥ 1	≥ 1	5	≥ 1	5	
Quick digital inputs	Interrupt-enabled, typ. 50 µs, can be used as probe	2	2	2	2	2	2	2	
Quick digital inputs (probe)	Scanning time	µs	500	500	500	83	41	500	500
Analog inputs	Number	1	1	1	≥ 1	3	≥ 1	3	
Analog outputs	Number	–	2 (o)	2 (o)	2 (o)	2 (●)	2 (o)	2 (●)	
Logic Control									
PLC runtime system									
Logic 2G kernel	As per IEC 61131-3 with addition	o	o	o	o	o	●	●	
Program organization	As per IEC 61131-3	●	●	●	●	●	●	●	
Loading and execution of the IEC 61131-3 applications		●	●	●	●	●	●	●	
Task management									
Freely configurable tasks (priority 0-20)	Cyclic, free-running, event-controlled, externally event- controlled	4	4	4	4	4	4	4	
Processing of the I/O process image	Clock-synchronous	●	●	●	●	●	●	●	
	Sercos-synchronous	●	●	●	●	●	●	●	
PLC cycle time	Synchronous to the system cycle	ms	≥ 1	≥ 1	≥ 1	≥ 1	≥ 1	≥ 1	
	Synchronous to the Sercos cycle	ms	≥ 1	≥ 1	≥ 1	≥ 1	≥ 1	≥ 1	
Motion cycle time	Command value generator	ms	≥ 1	≥ 1	≥ 0.25	≥ 1	≥ 0.25	≥ 1	≥ 0.25
PLC processing times									
Typical processing time for 1 000 instructions	Command mix (real, integer, Boolean, etc.)	µs	260	100	50	260	50	100	50
	Boolean operations	µs	270	100	50	270	50	100	50
	Word operations	µs	240	90	45	240	45	90	45

Technical specifications								
Type		MLD-S ¹⁾ IndraDrive Mi	MLD-S ¹⁾ IndraDrive Cs	MLD-M ²⁾ IndraDrive Cs	MLD-S ¹⁾ IndraDrive C/M	MLD-M ²⁾ IndraDrive C/M	MLD-S ¹⁾ IndraDrive ML	MLD-M ²⁾ IndraDrive ML
Drive systems – electrical axes								
IndraDrive C, M, ML	BASIC and ADVANCED single-axis control units with Drive Software MPB/MPC	–	–	–	●	●	●	●
IndraDrive Mi	With Drive Software MPB	●	–	–	–	–	–	–
IndraDrive Cs	BASIC and ADVANCED with Drive Software MPB/MPC	–	●	●	–	–	–	–
Control communication	Sercos	●	●	●	●	●	●	●
PLC cycle time	Synchronous to the Sercos cycle	ms ≥ 1	≥ 1	≥ 0.25	≥ 1	≥ 0.25	≥ 1	≥ 0.25
Motion control								
Number of axes	Real	1	1	1	1	1	1	1
	Virtual	1	1	10	1	10	1	10
	Encoder	2	2	2	2	2	2	2
	Group	0	0	1	0	1	0	1
Synchronization (ELS – Electronic Line Shaft)	Real axes (servo drives)	●	●	●	●	●	●	●
	Virtual axes (virtual masters)	●	●	●	●	●	●	●
	Encoder axes (real masters)	●	●	●	●	●	●	●
	Grouped axes (cross communication)	●	–	●	–	●	–	●
	Dynamic synchronization	●	●	●	●	●	●	●
	Master axis cascading	–	–	●	–	●	–	●
Positioning	Single axis	●	●	●	●	●	●	●
Electronic gears		●	●	●	●	●	●	●
Electronic cams	Support point tables (drive-internally, max. 1 024 support points)	4	4	4	4	4	4	4
	Electronic Motion Profile (control-internal, motion profiles with max. 16 segments)	2	2	2	2	2	2	2
Torque control		●	●	●	●	●	●	●
Speed control		●	●	●	●	●	●	●
Motion commands according to PLCopen (selection)	MC_MoveAbsolute	●	●	●	●	●	●	●
	MC_MoveRelative	●	●	●	●	●	●	●
	MC_MoveVelocity	●	●	●	●	●	●	●
	MC_CamIn, MC_CamOut	●	●	●	●	●	●	●
	MC_GearIn, MC_GearOut	●	●	●	●	●	●	●

● Standard ○ Option ▼ In preparation

¹⁾ Drive-based single-axis motion control system (BASIC control unit CSB)²⁾ Drive-based multi-axis motion control system (ADVANCED control unit CSH)

MLD

■ For more information, please visit: www.boschrexroth.com/cat-mld

Technical specifications								
Type		MLD-S ¹⁾ IndraDrive Mi	MLD-S ¹⁾ IndraDrive Cs	MLD-M ²⁾ IndraDrive Cs	MLD-S ¹⁾ IndraDrive C/M	MLD-M ²⁾ IndraDrive C/M	MLD-S ¹⁾ IndraDrive ML	MLD-M ²⁾ IndraDrive ML
Motion control								
Expanded motion commands (selection)	MB_ReadListParameter	●	●	●	●	●	●	●
	MB_WriteListParameter	●	●	●	●	●	●	●
	MB_GearInPos	●	●	●	●	●	●	●
	MB_PhasingSlave	●	●	●	●	●	●	●
	MB_Home	●	●	●	●	●	●	●
	MB_ClearAllError	●	●	●	●	●	●	●
Expanded system functions (selection)								
Programmable limit switch		○	○	○	○	○	○	○
Measuring encoder		○	○	○	○	○	○	○
Fault tolerance to failure of connected units		○	○	●	○	●	○	●
Deactivation of	I/O	○	○	●	○	●	○	●
	Drives	–	–	●	–	●	–	●
Ring healing and redundancy		○	○	●	○	●	○	●
Direct cross traffic	For quick axis coupling	–	–	○	–	○	–	○
Technology functions (selection)								
Process control		○	○	○	○	○	○	○
Winder		○	○	○	○	○	○	○
Tension control		○	○	○	○	○	○	○
Cross cutters		○	○	○	○	○	○	○
Register control		○	○	○	○	○	○	○
Slotter		○	○	○	○	○	○	○
Kinetic buffering (incl. simulation with Simster, running memory BANF must be ordered separately)		○	○	○	○	○	○	○
Sequential programming SMC								
Function	The function toolkit “Sequential Programming” allows for the simple, user-friendly project planning of motion sequences. An extended command set for the Structured Text (ST) language allows for easy programming of cyclic and sequential procedures, supplementing IEC 61131-3. In addition, it uses a common syntax and interface, manages the common variables and resources and offers an integrated debugger. The sequential programming developed by Bosch Rexroth also simplifies complex projects in the highest degree of transparency.							
Available MLD variants	–		○	○	○	○	○	○

Technical specifications								
Type		MLD-S ¹⁾ IndraDrive Mi	MLD-S ¹⁾ IndraDrive Cs	MLD-M ²⁾ IndraDrive Cs	MLD-S ¹⁾ IndraDrive C/M	MLD-M ²⁾ IndraDrive C/M	MLD-S ¹⁾ IndraDrive ML	MLD-M ²⁾ IndraDrive ML
Diagnosis								
Diagnosis (status, warning, error)	Function modules (software)	●	●	●	●	●	●	●
	Parameter access diagnostic memory (software)	●	●	●	●	●	●	●
	Local via display (control hardware)	●	●	●	●	●	●	●
	Axis monitoring (e.g. power, encoder, limit values)	●	●	●	●	●	●	●
	Diagnostics memory (64 kB, max. 999 messages)	●	●	●	●	●	●	●
Debugging monitor for IEC applications		●	●	●	●	●	●	●
Engineering and operation								
IndraWorks Engineering		○	○	○	○	○	○	○
IDST service tool		●	●	●	●	●	●	●

● Standard ○ Option ▼ In preparation

¹⁾ Drive-based single-axis motion control system (BASIC control unit CSB)

²⁾ Drive-based multi-axis motion control system (ADVANCED control unit CSH)

Suitable products for MLD			
Engineering			Page
Engineering software		IndraWorks Engineering	374 ff.
Control components			
Drive-integrated control system		IndraDrive	230 ff.
Visualization and operation			
Industrial PC and HMI	Compact operator panels	VR21	84 f.
Drive components			
Servo drives	IndraDrive Mi	KSM02, KMS02, KMS03, KCU02, KMV03, KNK03, KLC03	216 ff.
	IndraDrive Cs	HCS01	232 ff.
	IndraDrive C	HCS02, HCS03	236 ff.
	IndraDrive M	HMV01, HMS01, HMD01, HMV02, HMS02	242 ff.
	IndraDrive ML	HMU05	256 ff.
Servo motors and planetary gearboxes		MS2N, MS2E, MKE, MSM, MAD, MAF, GTE, GTM	290 ff.
Kit motors		MCL, ML3, MLF, MBT, MBS, 1MB	338 ff.

MPC

Precision motion control system based on embedded control YM

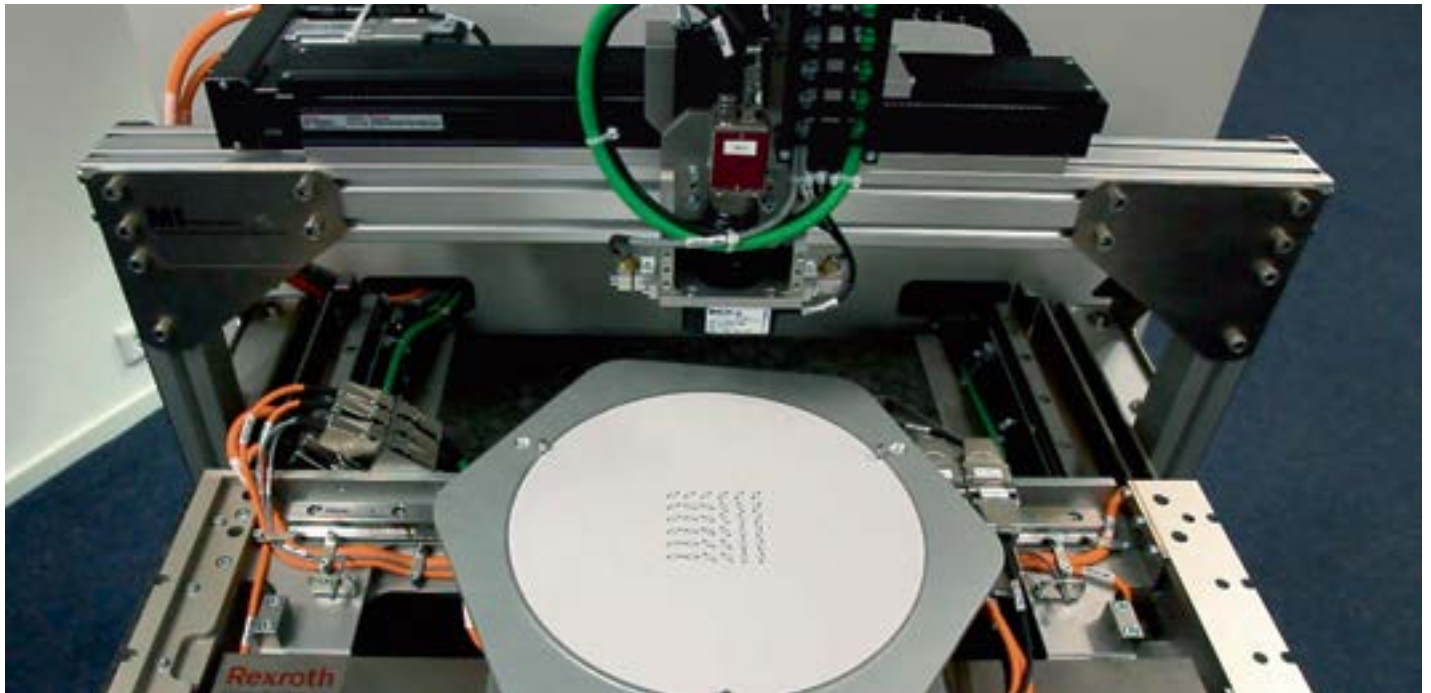

The precision motion control system MPC offers unparalleled flexibility. Highly developed hardware for complex processes in combination with an open software architecture ensures individually adapted motion solutions and simple integration into different automation landscapes.

- ▶ **Control platform with integrated drive amplifier and I/O**
- ▶ **Up to 12 axes and 120 I/O in one control node**
- ▶ **Up to 64 control nodes in one system**
- ▶ **High-level language programming (C/C++/.Net)**
- ▶ **Control with Linux operating system**
- ▶ **Maximum functionality in minimum space**

Applications:

- ▶ Semiconductor industry front-end and back-end
- ▶ Display production
- ▶ 3C industry (Computer, Communication, Consumer Electronic)

Your advantages at a glance

Compact design

- ▶ Compact size
- ▶ Integrated motion control, drive modules , I/O interfaces
- ▶ Scalable solutions thanks to modular design

Fast control

- ▶ Direct connection between motion sequence and I/O
- ▶ High-speed data acquisition, 32 channels at 32 kHz
- ▶ Quick digital I/O: Deceleration < 2 μ s
- ▶ Optimal measuring support

Extensive connection options

- ▶ Up to 620 controlled axes in one system
- ▶ Different motor types
- ▶ External drive modules via analog output and enable/disable function
- ▶ IndraDrive C/Cs compact converters via Sercos

Highly dynamic

- ▶ Extensive options of pilot control
- ▶ 32 kHz control loops for position and speed
- ▶ Maximum software flexibility

Smooth and vibration-free movements

- ▶ Command value function of 4. order
- ▶ Full PVT support
- ▶ Five filters for optimum control loop design

Fast development and commissioning

- ▶ Wide range of tools for commissioning
- ▶ Full support of software simulation
- ▶ Standard programming languages

Software

The NY4114 motion control module adds an open Linux-based variant to the product portfolio. NY4114 leverages other IT standards such as the Eclipse development environment with programming in C languages and integrates into horizontally and vertically networked industry 4.0 environments via open Ethernet-based communication. At the heart of the control system are modern multi-core processors with 1 GB RAM. The open Linux operating system with real-time extension is suitable for all common IT structures of manufacturing companies. Users program the multi-axis control using the Eclipse development environment with the world's most used programming languages C and C++. In addition, a development environment based on Visual Studio with C, C++ and .NET programming is also available. MPC-YM contains a simulation environment. This is a valuable tool for developing your application software to test applications without actually connecting to a control system or machine. Applications can be tested at an early stage of development on the PC even before the new machine is available.

■ For more information, please visit: www.boschrexroth.com/cat-mpc

Suitable products for MPC			
Control components			Page
Embedded control		YM	106 ff.
Visualization and operation			
Industrial PC and HMI	Box PC	PR21, PR31, PR4, VPB40.4	74 ff.
	Display	DR	80 f.
	Compact operator panels	VR21	84 f.
	Panel PC	VR31, VR4	86 ff.
Drive components			
Servo drives	IndraDrive Cs	HCS01	232 ff.
Servo motors and planetary gearboxes		MS2N, MS2E, MKE, MSM	290 ff.
Kit motors		MCL, ML3	338 ff.

FTS

Flexible Transport System based on embedded control YM



The Flexible Transport System FTS not only adapts to any size requirements, but also to a wide range of conditions that require maximum precision. With flexible hardware components plus intelligent software, FTS offers maximum possibilities.

- ▶ **For transport and precise positioning**
- ▶ **Individually scalable and flexibly adaptable**
- ▶ **Control components plus intelligent software**
- ▶ **High-level languages (C/C++/.Net) and PLC programming**
- ▶ **Also suitable for vacuum applications**

Applications:

- ▶ Front-end semiconductor industry
- ▶ Solar industry
- ▶ Battery production
- ▶ Display production
- ▶ Assembly and handling
- ▶ 3C industry (Computer, Communication, Consumer Electronic)

Your advantages at a glance

FTS is based on standard linear motor technology in which each individual work piece carrier is to be individually determined. The work piece carriers move independently of each other so even complex movement sequences can be easily implemented.

By combining several motors, FTS is also suitable for long production lines. Individual scalability and flexibility provide machine builders with maximum degrees of freedom when developing and realizing specific applications.

Extremely precise

FTS not only offers extreme positioning accuracy, but also high repeatability. This is ensured by sensors between the individual motors and the YM embedded control. Internal movement profiles enable high synchronism and high-precision positioning of the work piece carriers. This enables higher speeds to be implemented – but also very low speeds with low speed ripples, such as for coating processes. The intelligent embedded control YM guarantees high performance for every movement profile.

Individually scalable

FTS is suitable for any size requirement in production. For particularly long production lines, the system can be easily extended with several motors. The work piece carriers can easily absorb high weights and also move simple objects with the same positioning accuracy. The flexible “multi-carrier concept” allows positioning and movement of many work piece carriers independently of each other and provides system operators and users with additional possibilities for a successful manufacturing.

Can be flexibly adapted





Right from the start of product development, machine builders can precisely plan the desired material transport. The system offers maximum degrees of freedom and options. The software provides for the free programmability of all workpiece carrier movements – if necessary with I/O synchronization. A quick changeover to new products is therefore very simple. The mechanics adapt to every machine. The motors and magnetic plates can be mounted in different ways – no matter whether top, bottom or next to each other.

The use of large motors is also possible within the system in order to achieve a curve, for example. The distance between motor and magnetic plate can be scaled in order to mount the motors outside of a vacuum chamber. In addition, there are different possibilities for application-dependent guides: Track rollers, ball bushings and magnetic guides for a completely particle-free environment are already in successful use.

FTS

■ For more information, please visit: www.boschrexroth.com/cat-fts

Technical specifications			
Type			FTS
Repeatability per work piece carrier	With Hall sensor	µm	±20
	With MR sensor	µm	±1
Position accuracy for different work piece carriers	With Hall sensor	µm	±300
	With correction table	µm	±100
	With MR sensor	µm	±20
Speed		m/s	0 ... 5
Speed ripple at 20 mm/s	With Hall sensor	%	±5
	With correction table	%	±2
	With MR sensor	%	±1
Magnetic plates	Standard or vacuum-compatible	mbar	up to 10 ⁻⁸
	Temperature (NdFeB)	°C	up to 70
	Temperature (SmCo)	°C	up to 150
Distance between motor and magnetic plate		mm	0.5 ... 8
Workpiece carrier weight		kg	1 ... 2 000
Power range		kW	0.1 ... 20

Suitable products for FTS			
Control components			Page
	Scalable control platform YM with housing versions, control and drive modules	<ul style="list-style-type: none"> ▶ NYS04.2-ST-02-LMSN-NY4074 ▶ NYS04.2-ST-01-LMS-SERCOS-NY4079 	Page 108 f.
	A wide portfolio of coils from 60 to 3 000 N nominal force is available		More information on request
	Standard magnets and special vacuum magnets with an extended temperature range are available		More information on request
	Hall and MR sensors for high positioning accuracy are available		More information on request

ILC

IoT-enabled PLC system based on embedded control and industrial PC



The PLC system ILC offers a flexible industrial PC, embedded control, I/O and safety platform, including connection to the world of the IoT. It enables fast engineering, optimal connectivity, easy data availability, free choice of programming languages and is the future-proof solution for automating machines easily and efficiently. ILC can be used in a wide range of applications, for example in assembly, transport/logistics or test systems as well as in building automation.

The system is either based on an embedded control or an industrial PC. The high-performance software tools operated on this hardware base for visualization, process data processing, analysis and reporting significantly increase the performance of systems.

- ▶ **Free choice of programming language according to standard IEC 61131-3 incl. object orientation**
- ▶ **High-level language programming**
- ▶ **Best IoT connectivity and simple provision of data via OPC UA client/server on-board, expansion via IoT Gateway software**
- ▶ **Can be expanded with safety control up to PL e/Cat 4 (EN ISO 13849-1) or SIL 3 (IEC 62061)**

ILC – based on XM embedded control

The XM series of compact control platforms provides the latest hardware technology in a robust enclosure in the S20 format. It combines the excellent real-time capability of the Sercos automation bus and the flexibility and high performance of the S20 I/O series to create a modular and complete automation system.

- ▶ **EtherCAT I/O and Sercos on-board**
- ▶ **PROFINET IO, EtherNet/IP, PROFIBUS and MultiEthernet optional**
- ▶ **Easy functionality extension thanks to extension modules (communication, technology)**
- ▶ **Simple I/O integration through S20 I/O modules that can be directly connected in series or through integration of decentralized I/O stations via different fieldbuses**
- ▶ **Fast I/O process data processing in different operation modes (asynchronous, clock-synchronous, cyclic)**
- ▶ **PLC cycle times of 250 µs**

ILC – based on industrial PC VPB

On the basis of the VPB40, ILC offers a powerful and flexible industrial PC control solution. In addition to the PLC application, high-performance software tools for visualization, process data processing, analysis or reporting can be operated on the same control hardware.

A subordinate hypervisor distributes the hardware resources of the box PC designed for operation in control cabinets to the IoT-capable PLC system ILC and the open operating system Windows 7/10.

- ▶ **Complete control system with fast process data processing and maximum PLC performance**
- ▶ **Windows 7/10 and IoT-enabled PLC system on one hardware**
- ▶ **Modular expansion options with PCIe plug-in cards**

ILC

■ For more information, please visit: www.boschrexroth.com/cat-ilc

Technical specifications Control						
Type			XM21	XM22	XM42	VPB40.4
Design			Embedded control	Embedded control	Embedded control	Control cabinet PC
Runtime system	Integrated PLC system		●	●	●	●
Multitasking			●	●	●	●
System events			●	●	●	●
Data management	Code, data, remanent data, user data		●	●	●	●
Saving	Boot project		●	●	●	●
	PLC project as packed archive file		●	●	●	●
	User data in the internal memory and removable memory		●	●	●	●
Extension modules			3	3	3	4 (PCIe)
Slots	PCI Express (PCIe)		–	–	–	4
User memory	Total: code, data	MB	36	36	1 024	64
Remanent memory	Total: system, user	kB	128 ¹⁾	128 ¹⁾	4 096 ¹⁾	2 048 ¹⁾
Processor			Atom	Atom	Core i3	Core i7
Total memory		GB	0.5	0.5	2	16
Operating system			Wind River Systems VxWorks	Wind River Systems VxWorks	Wind River Systems VxWorks	Wind River Systems VxWorks and Microsoft Windows 7/10, hypervisor mode
On-board diagnostics and settings						
Status display (boot, Sercos, test)	LED (XM) or System Tray Application (VPB40.4)		●	●	●	●
Errors, warnings, messages, system reset	LED (XM) or System Tray Application (VPB40.4)		●	●	●	●
Ethernet settings (IP address)	First Touch		●	●	●	●
Voltage monitoring, watchdog	LED		●	●	●	–
Service Tool WebAssistant/First Touch	Web-based engineering		●	●	●	●
Automation protocols						
OPC UA	Server/client		○	○	○	○
BACnet	Server/client		○	○	○	○
MQTT	Broker		○	○	○	○

Technical specifications Control						
Type		XM21	XM22	XM42	VPB40.4	
On-board communication interfaces						
Sercos	Automation bus	●	●	●	●	
EtherCAT IO		○	○	○	–	
PROFINET IO	Controller (master)	–	–	○	–	
	Device (slave)	–	–	○	–	
EtherNet/IP	Scanner (master)	–	–	○	–	
	Adapter (slave)	–	–	○	–	
Ethernet TCP/IP		●	●	●	●	
Control link	Ethernet TCP/UDP/IP	●	●	●	●	
USB host/device	On-board	●	●	●	●	
External service monitor	DisplayPort	–	–	–	●	
Video interface	CDI+ LongDistanceVideo 100 m, single cable	–	–	–	●	
Extension modules (PCIe)						
Number		3	3	3	4 (PCIe)	
PROFIBUS master/slave		○	○	○	●	
PROFINET controller/device		○	○	○	●	
EtherNet/IP scanner/adapter		○	○	○	●	
SafeLogic	Safety control according to IEC 61508 (SIL 3) and EN ISO 13849-1 (PL e/Cat 4)	○	○	○	○	
HMI						
VR, PR/DR	Ethernet TCP/IP, OPC UA	○	○	○	○	
Input/output						
Can be added locally to control system						
S20 (digital, analog, relay, technology, communication, safety)	64 byte, max. 63 I/O	○	○	○	–	
Decentralized via S20 bus coupler (IP20)						
Sercos	On-board	○	○	○	● (PCIe)	
EtherCAT IO	On-board	○	○	○	–	
PROFIBUS	Extension module	○	○	○	○	
EtherNet/IP	Extension module/on-board	○/–	○/–	○/○	○	
PROFINET	Extension module/on-board	○/–	○/–	○/○	○	
Decentralized via S67E bus coupler (IP67)						
Sercos	On-board	○	○	○	○	
PROFINET	On-board	○	○	○	○	

● Standard ○ Option ▼ In preparation

¹⁾ 50 % available for PLC user, 50 % reserved for motion control applications

ILC

■ For more information, please visit: www.boschrexroth.com/cat-ilc

Technical specifications Control						
Type			XM21	XM22	XM42	VPB40.4
Logic control						
PLC runtime system						
Logic 2G kernel	As per IEC 61131-3 with addition		●	●	●	●
Program organization	As per IEC 61131-3		●	●	●	●
Loading and execution of the IEC 61131-3 applications			●	●	●	●
Task management						
Freely configurable tasks (priority 0-20)	Cyclic, free-running, event-controlled, externally event-controlled		20	20	20	20
Processing of the I/O process image	Cycle-synchronous		●	●	●	–
	Clock-synchronous		●	●	●	●
PLC cycle time	Synchronous to the system cycle	ms	≥ 1	≥ 1	≥ 1	≥ 1
	Synchronous to the Sercos cycle	ms	–	–	–	≥ 0.25
PLC processing times						
Typical processing time for 1 000 instructions	Command mix (real, integer, Boolean, etc.)	μs	26	13	2	2
	Boolean operations	μs	5	5	4	4
	Word operations	μs	5	5	1	1
Diagnosis						
Diagnosis (status, warning, error)	Function modules (software)		●	●	●	●
	Parameter access diagnostic memory (software)		●	●	●	●
	Local via status display (control hardware)		●	●	●	●
	Axis monitoring (e.g. power, encoder, limit values)		●	●	●	●
	Diagnostics memory (64 kB, max. 999 messages)		●	●	●	●
Debugging monitor for IEC applications			●	●	●	●
Engineering and operation						
IndraWorks	Engineering tool		○	○	○	○
First Touch	Web-based commissioning		●	●	●	–

Technical specifications Control

Type		XM21	XM22	XM42	VPB40.4
Engineering and operation					
WebAssistant (web-based engineering)					
Function		The WebAssistant is a web-based operating interface for maintenance, service and diagnosis of MLC/ILC automation systems. The webpages are located directly on the control and can be easily called up via a standard browser. The WebAssistant is automatically adjusted to the resolution of the browser. The operating interface optimized for touch operation can be customized with the help of the WebComposer.			
Pre-defined web interface		●	●	●	●
Can be expanded customer-specifically	Using IndraWorks WebComposer	○	○	○	○
Integrated web server on the control system	Visualization via a standard web browser	●	●	●	●
Underlying web technologies	HTML5	●	●	●	●
	JavaScript	●	●	●	●

● Standard ○ Option ▼ In preparation

Suitable products for ILC

Engineering			Page
Engineering software		IndraWorks Engineering	374 ff.
Control components			
Embedded control		XM21, XM22	98 f.
		XM42	100 f.
Industrial PC control	Box PC	VPB40.4	78 f.
Visualization and operation			
Industrial PC and HMI	Box PC	PR21, PR31, PR4, VPB40.4	74 ff.
	Display	DR	80 f.
	Compact operator panels	VR21	84 f.
	Panel PC	VR31, VR4	86 ff.
	Machine operator panels	VAM15, VAM21	90 ff.
System periphery			
I/O systems	IP20	S20	118 ff.
	IP67	S67E	158 ff.
Drive components			
Frequency converters		EFC3610, EFC5610	198 ff.
Servo drives	IndraDrive Mi	KSM02, KMS02, KMS03, KCU02, KMV03, KNK03, KLC03	216 ff.
	IndraDrive Cs	HCS01	232 ff.
	IndraDrive C	HCS02, HCS03	236 ff.
	IndraDrive M	HMV01, HMS01, HMD01, HMV02, HMS02	242 ff.
	IndraDrive ML	HMU05	256 ff.
Servo motors and planetary gearboxes		MS2N, MS2E, MKE, MSM, MAD, MAF	290 ff.
Kit motors		MCL, ML3, MLF, MBT, MBS, 1MB	338 ff.

IoT Gateway

IoT system for new and existing machines

IoT
Gateway



The IoT Gateway connects new and existing machines simply and cost efficiently with the IoT world. This makes previously unused machine and process data transparent and usable. Real-time monitoring of process data such as temperature, pressure, vibration, etc. ensures consistently high quality in manufacturing. The rule-based evaluation of specific machine information simplifies the predictive service of the systems. In this way, the product lifecycle of existing machines can be extended.

- ▶ **Plug-and-run – browser-based configuration**
- ▶ **Everything from a single source – solutions ranging from sensors to the cloud**
- ▶ **Connectivity – connection of a multitude of data sources and IT systems possible**
- ▶ **Device Management via Device Portal – central access to management of your IoT devices (remote access, backup/restore, software deployment)**
- ▶ **Firewall and VPN network segmentation, protection against unauthorized access by third parties and setup of a VPN tunnel for secure remote maintenance**

■ For more information, please visit: www.boschrexroth.com/cat-iot-gateway

Technical specifications				
Type			PR21	Software only
General information				
Operating system	Linux Ubuntu Core		●	–
	Customer-specific – Java Virtual Machine required		–	●
Java Virtual Machine (JVM)	Java Runtime based on OpenJDK-8		●	–
OSGI	Bosch IoT Gateway software 9.0		●	●
Software apps				
System	IoT Core		●	●
	Dashboard app		●	●
	Backup restore		●	●
Devices app	S20-ETH-BK-Devices S20-AI-4I (Bosch Rexroth, 4 analog inputs, current)		○	○
	S20-ETH-BK-Devices S20-DI-16/1 (Bosch Rexroth, 16 digital inputs)		○	○
	OPC UA client		○	○
	OPC DA Client		○	○
	Open Core Interface for controls		●	●
	Siemens S5 client		○	○
	Siemens S7 client		○	○
	Beckhoff ADS client		○	○
	Allen-Bradley ControlLogix client		○	○
	MQTT client		○	○
	S/IP client		●	●
	Rexroth Drive Interface		○	○
	CISS sensor (Bosch)		○	○
Device Simulator		●	●	

● Standard ○ Option ▼ In preparation

IoT Gateway

■ For more information, please visit: www.boschrexroth.com/cat-iot-gateway

Technical specifications				
Type			PR21	Software only
Software apps				
Processing app	Functions	Mathematical basic operations	●	●
		Boolean basic functions	●	●
		Average formation	●	●
		Factor calculation	●	●
		Dead band filter	●	●
		Limit filter	●	●
		Threshold monitor	●	●
		Nelson rules monitor	●	●
		Range converter	●	●
		Formatter	●	●
		Applications	Amazon Cloud (AWS Cloud)	○
	Bosch Rexroth Online Diagnostic Network (ODiN)		○	○
	Bosch Production Performance Manager (PPM)		○	○
	MQTT		○	○
	PPMP		○	○
	Microsoft Azure (IoT Hub)		○	○
	MongoDB		○	○
	MySQL		○	○
	TCP/IP	○	○	

Technical specifications					
Type		PR21	Software only		
Industrial security					
IoT security	Firewall/packet filter		○	–	
	Access control		●	–	
	Virtual Private Network (VPN)	OpenVPN		○	–
		IpSec		○	–
	Logging interface		▼	–	
	Certificate management interface		▼	–	
	IEC 62443 certification		▼	–	
Device management					
Device portal	Device inventory		○	▼	
	Device status monitoring		○	▼	
	Remote access		○	▼	
	Backup restore configuration		▼	▼	
	Provision of software		▼	▼	
	Device updates/upgrades		▼	▼	
	Device security updates		▼	▼	

● Standard ○ Option ▼ In preparation

Suitable products for the IoT Gateway		
Control components		Page
Industrial PC	PR21	74 f.
IoT hardware		
IoT Rack		188 f.
IoT sensors		190 f.

IoT Insights

IoT system for greater transparency in manufacturing

IoT
Insights



IoT Insights is a complete solution for storing, visualizing, and monitoring production and machine data. In addition to the IoT Gateway software and hardware, it also includes optional sensors. The individual components are perfectly coordinated and can be put into operation very quickly and easily. User guidance is highly intuitive; functions can also be easily extended during operation.

- ▶ **Introductory solution for visualization, monitoring and first evaluation of data in production**
- ▶ **Overall package including hardware and software: IoT Gateway software, optionally in the IoT Rack, dashboard software and database**
- ▶ **Useful features: Number of items, cycle time, alarms, comparisons**
- ▶ **Local operation on the machine as edge solution**
- ▶ **Data can remain within the company**
- ▶ **Simple, safe and quick commissioning at the machine or line**
- ▶ **Flexibly expandable with customer-specific features**

■ For more information, please visit: www.boschrexroth.com/cat-ae

Technical specifications					
Type			IoT Insights Standard	IoT Insights Advanced	
Hardware					
IoT Rack	incl. PR21 IPC		o	o	
IoT Rack EdgeComputing	incl. PR43 IPC		o	o	
Software					
IoT Gateway software			●	●	
IoT Insights dashboard			●	●	
Database			●	●	
Easy Analytics			o	o	
Sensors					
CISS			o	o	
SCD			o	o	
Analog and digital sensors			o	o	
Additional functions					
Email			▼	▼	
SMS			▼	▼	
Industrial security					
IoT security	Firewall/packet filter		o	o	
	Access control		●	●	
	Virtual Private Network (VPN)	OpenVPN		o	o
		IpSec		o	o
	Logging interface		▼	▼	
	Certificate management interface		▼	▼	
	IEC 62443 certification		▼	▼	
Device management					
Device portal	Device inventory		o	o	
	Device status monitoring		o	o	
	Remote access		o	o	
	Back-up restore configuration		▼	▼	
	Software deployment		▼	▼	
	Device updates/upgrades		▼	▼	
	Device security updates		▼	▼	

● Standard o Option ▼ In preparation

Suitable products for IoT Insights		
IoT hardware		Page
IoT Rack		188 f.
IoT sensors		190 f.

CONTROL COMPONENTS

3

Portfolio

68

- ▶ Control components

68

Industrial PC and HMI

70

- ▶ Box PC
- ▶ Display
- ▶ Compact operator panels
- ▶ Panel PC
- ▶ Machine operator panels

74

80

84

86

90

Embedded controls

94

- ▶ XM
- ▶ YM

96

106

I/O systems

116

- ▶ S20
- ▶ S67E

118

158

Safety control

164

- ▶ SafeLogic
- ▶ SafeLogic compact

166

172

IoT hardware

186

- ▶ IoT Rack
- ▶ IoT sensors

188

190

Portfolio

Control components

Embedded controls



XM
 Logic, motion and CNC control
 Up to 2 MB RAM
 Up to 4 GB flash



YM
 High precision motion control
 32 kHz

Industrial PC



PR
 Box PC
 Up to Core i7
 Dual Core



VPB
 Box PC
 Core i7
 Quad Core

IoT hardware – edge devices for IoT solutions



IoT Gateway
 PR21



IoT Rack
 IoT solution



IoT sensors
 SCD/CISS

HMI



VR21
 Multi-touch panel, 16:9 (active)
 4" | 7" | 9"



DR
 Multi-touch display, 16:9 (passive)
 12" | 15" | 18" | 21"

Safety control



VR
Multi-touch panel PC, 16:9
Up to Core i7
10" | 15" | 21"



SafeLogic
Safety-CPU
XMxx, VPB



SafeLogic compact
Compact safety control

I/O systems



VDP
4:3 display (passive)
10.4"



VAM
Machine operator panel



S20
IP20
Modular, centralized
and decentralized



S67E
IP67
Decentralized
(IO link)

Industrial PC and HMI

Industrial PC and HMIs are key elements for increasing productivity and efficiency in manufacturing. For the lower and high power range, industrial PC and HMIs from Bosch Rexroth provide a high degree of flexibility in all industrial applications.



Industrial PC and HMI 72

Box PC – PR21	74
Box PC – PR31, PR4	76
Box PC – VPB40.4	78
Multi-touch display – DR	80
Display – VDP81, VDP82	82
Compact operator panels – VR21	84
Panel PC – VR31, VR4	86
Machine operator panels – VAM15, VAM21	90
Machine operator panels – VAM81, VAM82	92

Industrial PC and HMI

The wide portfolio of industrial PC, displays and operating panels from Bosch Rexroth is suitable for standard applications as well as for high-end applications. They offer scaled performance, high system availability and a variety of configuration options. With the industrial PC and HMIs you are able to handle a variety of tasks in all industrial applications.

Information on other industrial PC and HMI components (VPP, VDP, VH, VCH, VEP, VAM) can be found at www.boschrexroth.com/automation.

- ▶ **Scaled and coordinated portfolio for standard and high-end applications**
- ▶ **Designed for a long service life in harsh environment conditions**
- ▶ **Compact design for easy integration into existing machine concepts**
- ▶ **Future-proof thanks to state-of-the-art technology and long-term availability**



▶ **Box PC**

The box PC are available in different versions to suit every requirement, e.g. with regard to hardware, computing power, memory capacity, interfaces and much more.



▶ **Displays**

A variety of display format scaling as well as different installation positions make the displays an ideal solution platform for all HMI-based applications.



▶ **Machine operator panel**

The convenient machine operator panels optimize individual operating concepts of the machine.



▶ **Compact operator panels**

Compact operator panels for controlling and visualizing machines are the perfect solution for displaying comprehensive data.



▶ **Panel PC**

Panel PC combine the properties of the box PC and the positioned displays to form a compact PC solution.

Box PC

PR21



The compact box PC of the PR21 series are available in different housing versions. The HDMI interface can be used to connect a display. The use of the Intel Atom processor with low power losses enables a fanless device design. High performance as well as a multitude of expansion options and standard interfaces make the box PC PR21 the ideal solution platform for all IoT Gateway applications, ideally suited for industry 4.0.

- ▶ **CPU: Intel Atom E3815**
- ▶ **RAM: 4 GB**
- ▶ **Operating system: Linux Ubuntu Core**
- ▶ **Slots: 1 x mPCIe interface module or mSATA mass memory**
- ▶ **Mass memory: 32 GB eMMC on-board**
- ▶ **Video interface: 1 x HDMI**

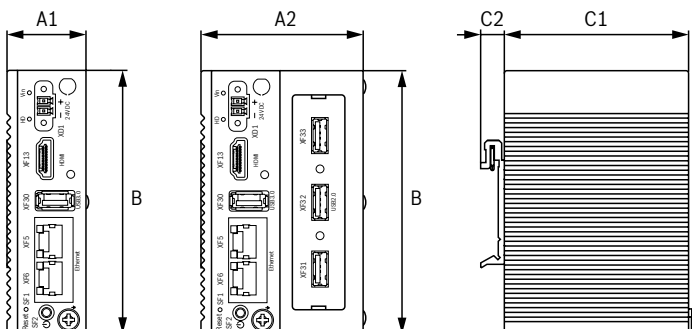

Dimensions		
Type		PR21
A1	mm	30
A2	mm	60
B	mm	100
C1	mm	70
C2	mm	6.5
Mass	kg	0.4

■ For more information, please visit: www.boschrexroth.com/cat-pr

Technical specifications		
Type		PR21
Power data		
CPU		Intel Atom E3815; 1.46 GHz
RAM	GB	4
Operating system		Linux Ubuntu Core
Hardware		
Mini PCIe slots		1 x full-size mSATA
Flash memory	GB	32, eMMC
SSD memories (optional)	GB	64, mSATA
	GB	256, mSATA
Interfaces		
Ethernet		2 x Realtek RTL8111E GbE
Ethernet (optional)		Hardware variant NA: 2 x Gbit (Intel i350)
USB host		1 x USB 3.0
		Hardware variant NB: 3 x USB 2.0
Video interface		1 × HDMI
Serial interface		Hardware variant NC: 2 x RS232/422/485
Electrical data		
Supply voltage	V DC	24
	%	-20/+25
Max. power consumption	W	20
EMC		Class A
RTC buffering		Internal battery
Mechanical tests		
Vibration resistance	g	2
Shock resistance	g	10
General data		
Ambient temperature (operation)	°C	+0 ... +50
Ambient temperature (storage/transport)	°C	-20 ... +70
Permissible humidity (operation)	%	85 (at 40 °C, non-condensing)
Assembly		DIN rail mounting
Cooling		Convection (fanless)
Degree of protection – overall		IP20

¹⁾ In preparation

Box PC

PR31, PR4



The compact box PC of the PR series are available in different versions. Various interfaces can be used to connect the spatially separated DR multi-touch displays. The use of the latest processor generation with low power losses gives the device design a fanless device design. High performance as well as a variety of expansion options and standard interfaces, including real-time Ethernet communication, make the box PC PR the ideal solution platform for all HMI-based applications. The integrated TPM 2.0 chip provides the necessary security in the IoT environment. This makes the robust units ideal for Industry 4.0.

- ▶ **CPU: Intel Atom, Core i3/i5/i7**
- ▶ **RAM: 4 ... 16 GB**
- ▶ **Operating system: Windows 10 IoT Enterprise**
- ▶ **Extension slots: Half size PCIe, mini PCIe**
- ▶ **Mass memory: SSD, HDD**

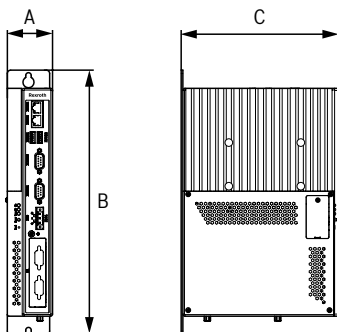

Dimensions			
Type		PR31	PR4x
A	mm	50	83
B	mm	269	269
C	mm	181	181
Mass	kg	2.8	4.6

■ For more information, please visit: www.boschrexroth.com/cat-pr

Technical specifications			
Type		PR31	PR4x
Power data			
CPU		Intel Atom x5-E3940; 1.6 GHz	Intel Core i3-6100U; 2.3 GHz
		–	Intel Core i5-6300U; 2.4 GHz
		–	Intel Core i7-6600U; 2.6 GHz
RAM	GB	4	8
RAM (optional)	GB	8	16
Operating system		Windows 10 IoT Enterprise	Windows 10 IoT Enterprise
Hardware			
PCI/PCIe slots		–	1 x half-size PCIe
Mini PCIe slots		1 x full-size mini PCIe	2 x full-size mini PCIe
Flash memory (optional)		M.2 flash + CFast-slot	M.2 flash + CFast-slot
SSD memories	GB	32	32
		256	256
		–	2 x 256 (RAID 1) ¹⁾
HDD memory	GB	320 ¹⁾	320 ¹⁾
		–	2 x 320 (RAID 1) ¹⁾
Interfaces			
Ethernet		2 x Gbit (Intel i210)	2 x Gbit (Intel i210)
		–	1 x Gbit (Intel i219)
USB host		2 x USB 2.0	2 x USB 2.0
		2 x USB 3.0	2 x USB 3.0
Video interface (standard)		DisplayPort	DisplayPort
Video interface (optional)		CDI+ LongDistanceVideo 100 m, single cable	
Serial interface		1 x RS232	1 x RS232
		1 x RS232/422/485	1 x RS232/422/485
Audio interface		Line out	Line out
Electrical data			
Input voltage	V DC	24	24
	%	-20/+25	-20/+25
Max. power consumption	W	19.2	70
EMC		Class A	
RTC buffering		Internal battery	
UPS		External (VAU02.1)	
Mechanical tests			
Vibration resistance SSD	g	2	2
Vibration resistance HDD	g	0.3	0.3
Shock resistance	g	10	10
General data			
Ambient temperature (operation)	°C	+0 ... +55	+0 ... +55
Ambient temperature (storage/transport)	°C	-20 ... +60	-20 ... +60
Permissible humidity (operation)	%	85 (at 40 °C, non-condensing)	
Assembly		Wall assembly	
Cooling		Convection (fanless)	
Degree of protection		IP20	IP20

¹⁾ In preparation

Box PC

VPB40.4



The box PC VPB40.4 is available in different device versions. High performance as well as a variety of expansion options and interfaces, including real-time Ethernet communication, make the box PC VPB40.4 the ideal solution platform for all HMI-based applications.

- ▶ **Industrial PC for control cabinet installation**
- ▶ **Powerful automation platform**
- ▶ **Variants with 2 or 4 slots available**
- ▶ **Designed for rough industrial applications**

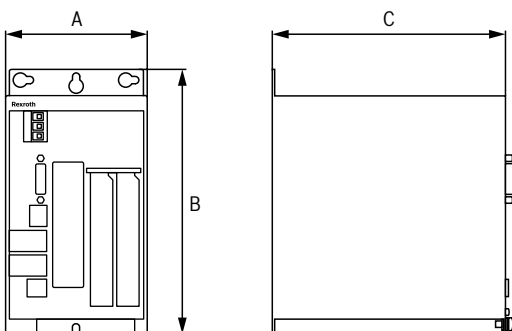

Dimensions			
Type		VPB40.4 (2-slot variant)	VPB40.4 (4-slot variant)
A	mm	110	92.5
B	mm	205.5	326
C	mm	181.5	194.5
Mass	kg	2.6	3.3

■ For more information, please visit: www.boschrexroth.com/cat-vpb

Technical specifications			
Type	VPB40.4 (2 slot variant)		VPB40.4 (4 slot variant)
Processor			
CPU		Intel Celeron C3955U; 2.0 GHz	Intel Celeron C3955U; 2.0 GHz
		Intel Core i5-6300U; 2.4 GHz	Intel Core i5-6300U; 2.4 GHz
		Intel Core i7-6820EQ; 2.8 GHz	Intel Core i7-6820EQ; 2.8 GHz
Operating system		Windows 7, Windows 10	Windows 7, Windows 10
Hardware			
PCI/PCIe slots		2/0; 1/1; 0/2	4/0; 2/2; 0/4
SSD memories	GB	192	192
HDD memory (optional)	GB	320	320
	GB	2 x 320 (RAID 1)	2 x 320 GB (RAID 1)
Memory			
Use/application	GB	8	8
	GB	16	16
Interfaces			
Ethernet		2 x Ethernet TCP/IP (1 GBit/s)	2 x Ethernet TCP/IP (1 GBit/s)
USB host		2 x USB 3.0	2 x USB 3.0
		4 x USB 2.0	4 x USB 2.0
Video interface		CDI+ LongDistanceVideo 100 m, single cable	
External service monitor		DisplayPort	DisplayPort
Electrical data			
Supply voltage	V DC	24	24
	%	-20/+25	-20/+25
Power consumption	W	150	150
UPS		External	External
Mechanical tests			
Vibration resistance	g	1	1
Shock resistance	g	15	15
General data			
Ambient temperature (operation)	°C	+5 ... +45	+5 ... +45
Permissible humidity (operation)	%	5 ... 85, EN 61131-2	5 ... 85, EN 61131-2
Degree of protection		IP20	IP20

Multi-touch display

DR

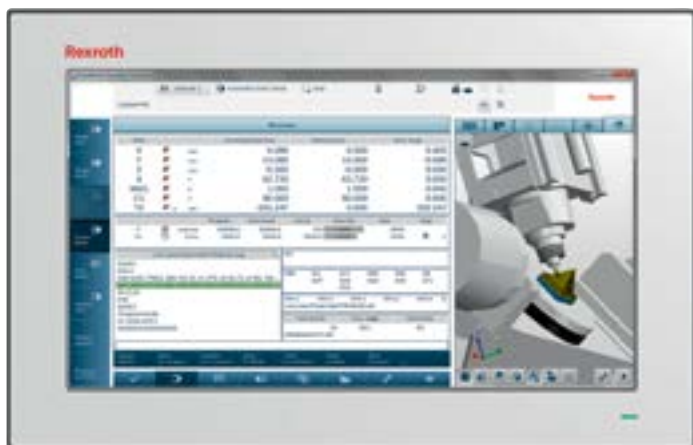

The high-resolution displays of the DR series are available in scaled sizes. They enable exact operation by means of a capacitive 10-point multi-touchscreen. Horizontal and vertical installation is possible. Anti-reflective and chemically hardened front glass makes them insensitive to adverse environmental influences and guarantees a long useful life. Due to the long-distance interface, up to three displays can be connected to a PC.

- ▶ **Multi-touch gesture control**
- ▶ **Widescreen display formats 12 ... 21"**
- ▶ **Horizontal and vertical installation**
- ▶ **Robust due to non-reflecting and chemical hardened front glass**
- ▶ **Networking of up to four displays in line**

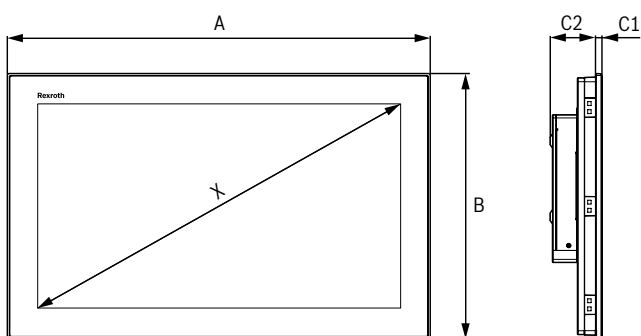

Dimensions		DR0012	DR0015	DR0018	DR0021
Type					
A	mm	329	420	488	558
B	mm	231	269	309	350
C1	mm	7	7	7	7
C2	mm	58	58	58	58
X	mm	307	396	470	546
	in	12.1	15.6	18.5	21.5
Mass	kg	4.4	6.0	7.5	8.4

■ For more information, please visit: www.boschrexroth.com/cat-dr

Technical specifications					
Type		DR0012	DR0015	DR0018	DR0021
Display					
Type		TFT	TFT	TFT	TFT
Resolution		1 280 x 800	1 366 x 768	1 366 x 768	1 920 x 1 080
Aspect ratio		16:10	16:9	16:9	16:9
Operation		Capacitive 10-point multi-touchscreen			
Orientation		Horizontal ¹⁾			Horizontal/vertical
Interfaces					
USB host		2 x USB 2.0	2 x USB 2.0	2 x USB 2.0	2 x USB 2.0
Video interface (standard)		DisplayPort	DisplayPort	DisplayPort	DisplayPort
		CDI+ LongDistanceVideo 100 m, single cable			
		CDI+ LongDistanceVideo 100 m, daisy chain module (RX+TX)			
Electrical data					
Supply voltage	V DC	24	24	24	24
	%	-20/+25	-20/+25	-20/+25	-20/+25
Power consumption	W	21.3	20.6	25.3	32
EMC		Class A	Class A	Class A	Class A
General data					
Ambient temperature (operation)	°C	+0 ... +55	+0 ... +55	+0 ... +55	+0 ... +55
Ambient temperature (storage/transport)	°C	-20 ... +60	-20 ... +60	-20 ... +60	-20 ... +60
Permissible humidity (operation)	%	85 (at 40 °C, non-condensing)			
Assembly		Panel assembly			
Cooling		Convection (fanless)			
Degree of protection – front		IP66	IP66	IP66	IP66
Degree of protection – rear		IP20	IP20	IP20	IP20

¹⁾ Vertical in preparation

Display

VDP81, VDP82



The displays VDP81 and VDP82 are specially available for the MTX micro CNC system and optimized for use on CNC machines. These are available in scaled sizes. The flat displays can be mounted directly into the machine and form the optimum man-machine interface for the MTX micro CNC system.

- ▶ **Flat operating and display unit for installation**
- ▶ **Optimum man-machine interface for MTX micro CNC system**
- ▶ **10" TFT screen and membrane keyboard**
- ▶ **Designed for rough industrial applications**
- ▶ **Ideal for CNC machines for drilling, turning, milling, grinding, gear cutting**

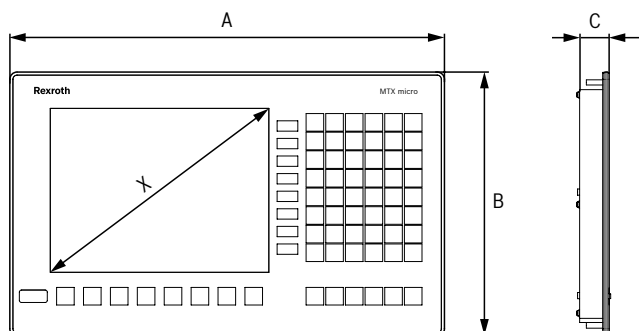

Dimensions			
Type		VDP81.1FKN	VDP82.1FKN
A	mm	420	300
B	mm	255	350
C	mm	25	25
X	cm	26	26
	in	10.4	10.4
Mass	kg	2.2	2.2

■ For more information, please visit: www.boschrexroth.com/cat-ae

Technical specifications			
Type		VDP81.1FKN	VDP82.1FKN
Operation			
Type		Keyboard operation	
Number of function buttons		8	8
Number of machine buttons		8	8
Number of additional buttons		54	54
Interfaces			
Type		1 x USB front	
		1 x interfaces for auxiliary devices	
Electrical data			
Supply voltage	V DC	24	24
	%	±20	±20
Power consumption	W	8	8
Display			
Type		TFT	TFT
Colors		262 144	262 144
Resolution		640 x 480	640 x 480
General data			
Color		RAL 7024, graphite gray	
Ambient temperature (operation)	°C	0 ... +45	0 ... +45
Permissible humidity (operation)	%	≤ 75, EN 61131-2	≤ 75, EN 61131-2
Degree of protection – overall		IP20	IP20
Degree of protection – front		IP54	IP54

Compact operator panels

VR21

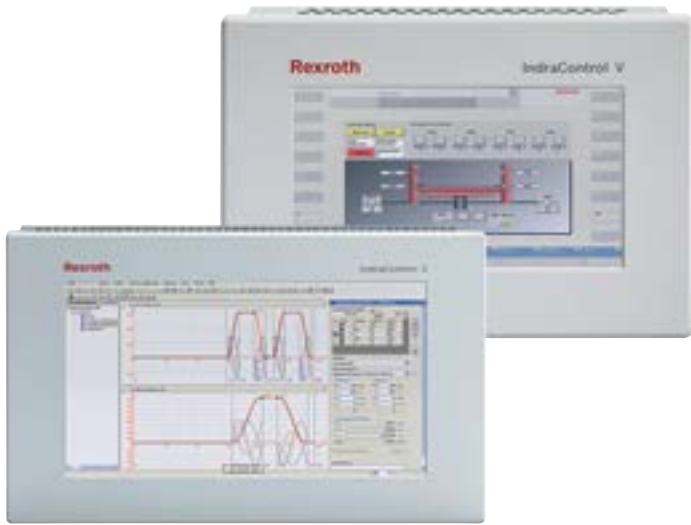

The VR21 compact operator panels are used for the simple control and visualization of machines and systems. TFT displays in widescreen format enable the detailed display of extensive machine data. With the different model versions with resistive or capacitive touchscreens, you can adjust the systems perfectly to your working habits. The included Ethernet interface supports the connection via OPC UA communication to each control system.

- ▶ **Widescreen TFT display: 4.3" / 7" / 9"**
- ▶ **Touchscreen: resistive and/or capacitive**
- ▶ **Completely maintenance-free**

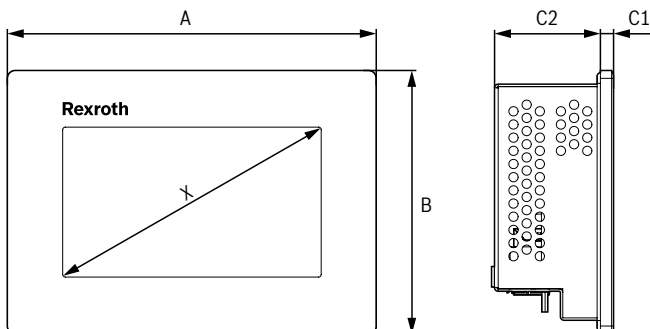

Dimensions				
Type		VR2104	VR2107	VR2109
A	mm	140	211	263
B	mm	100	150	178
C1	mm	5	5	5
C2	mm	40.2	43.9	49.9
X	mm	108.4	178	228
	in	4.3	7	9
Mass	kg	0.6	0.8	1.3

■ For more information, please visit: www.boschrexroth.com/cat-vr21

Technical specifications				
Type		VR2104	VR2107	VR2109
Memory				
Use/application	MB	512	512	512
Flash size	MB	256	256	256
Display				
Type		Widescreen TFT		
		Graphic-oriented		
Colors/grayscales		65 536	262 144	16.77 million
Resolution		480 x 272	800 x 480	800 x 480
Display				
Operation	Resistive		Touchscreen	
	Capacitive		–	Touchscreen
Interfaces				
Type		1 x Ethernet TCP/IP	1 x Ethernet TCP/IP	1 x Ethernet TCP/IP
		2x USB host	2x USB host	2x USB host
Electrical data				
Supply voltage	V DC	24	24	24
	%	–20/+25	–20/+25	–20/+25
Power consumption	Resistive	W	4.8	7.2
	Capacitive	W	–	9.6
General data				
Ambient temperature (operation)	°C	0 ... +50	0 ... +50	0 ... +50
Permissible humidity (operation)	%	5 ... 85, EN 61131-2	20 ... 85, EN 61131-2	20 ... 85, EN 61131-2
Degree of protection – front		IP65	IP65	IP65
Degree of protection – rear		IP20	IP20	IP20

Panel PC

VR31, VR4



The VR series panel PC combine the properties of the box PC PR and the positioned multi-touch displays DR. The versatile display format scaling, high performance and a variety of expansion options and standard interfaces, including real-time Ethernet communication, make the panel PC VR the ideal solution platform for all HMI-based applications. The integrated TPM 2.0 chip provides the necessary security in the IoT environment. This makes the robust units ideal for Industry 4.0.

- ▶ **16:9 display: 10" / 15" / 21"**
- ▶ **CPU: Intel Atom, Core i3/i5/i7**
- ▶ **RAM: 4 ... 16 GB**
- ▶ **Operating system: Windows 10 IoT Enterprise**
- ▶ **Extension slots: Half size PCIe, mini PCIe**
- ▶ **Mass memory: SSD, HDD**

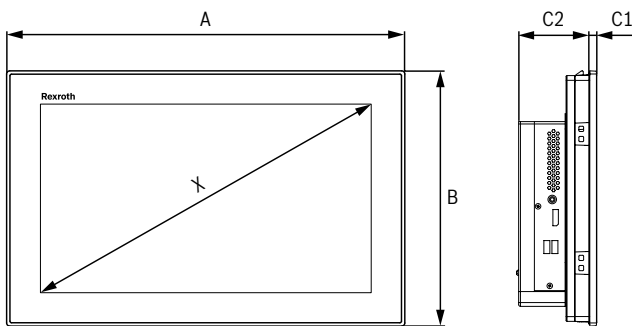

Dimensions						
Type		VR3110	VR3115	VR3121	VR4x15	VR4x21
A	mm	238	420	558	420	558
B	mm	202	269	350	269	350
C1	mm	7	7	7	7	7
C2	mm	75	75	75	108	108
X	mm	257	396	546	396	546
	in	10.1	15	21	15	21
Mass	kg	4.1	7	9.4	8.7	11.1

■ For more information, please visit: www.boschrexroth.com/cat-vr

Technical specifications			
Type		VR31	VR4x
Display			
Screen diagonal	mm/in	257/10 (1 280 x 800)	–
		396/15 (1 366 x 768)	396/15 (1 366 x 768)
		546/21 (1 920 x 1 080)	546/21 (1 920 x 1080)
Aspect ratio		16:9	16:9
Operation		Capacitive 10-point multi-touchscreen	
Orientation		Horizontal	
		Vertical ¹⁾	
Power data			
CPU		Intel Atom x5-E3940; 1.6 GHz	Intel Core i3-6100U; 2.3 GHz
		–	Intel Core i5-6300U; 2.4 GHz
		–	Intel Core i7-6600U; 2.6 GHz
RAM	GB	4	8
RAM (optional)	GB	8	16
Operating system		Windows 10 IoT Enterprise	Windows 10 IoT Enterprise
Hardware			
PCI/PCIe slots		–	1 x half-size PCIe
Mini PCIe slots		1 x full-size mini PCIe	2 x full-size mini PCIe
Flash memory (optional)		M.2 flash + CFAST-slot	M.2 flash + CFAST-slot
SSD memories	GB	32	32
		256	256
		–	2 x 320 (RAID 1) ²⁾
HDD memory	GB	320 ²⁾	320 ²⁾
		–	2 x 256 (RAID 1) ²⁾
Interfaces			
Ethernet		2 x Gbit (Intel i210)	2 x Gbit (Intel i210)
		–	1 x Gbit (Intel i219)
USB host		2 x USB 2.0	2 x USB 2.0
		2 x USB 3.0	2 x USB 3.0
Video interface		DisplayPort	DisplayPort
Serial interface		1 x RS232	1 x RS232
		1 x RS232/422/485	1 x RS232/422/485
Audio interface		Line out	Line out

¹⁾ For VR3115, VR3121 and VR4x15 in preparation

²⁾ In preparation

Panel PC

VR31, VR4

■ For more information, please visit: www.boschrexroth.com/cat-vr

Technical specifications			
Type		VR31	VR4x
Electrical data			
Supply voltage	V DC	24	24
	%	-20/+25	-20/+25
Max. power consumption	W	27	85
EMC		Class A	
RTC buffering		Internal battery	
UPS		External (VAU02.1)	
Mechanical tests			
Vibration resistance SSD	g	2	2
Vibration resistance HDD	g	0.3	0.3
Shock resistance	g	10	10
General data			
Ambient temperature (operation)	°C	+0 ... +55	+0 ... +55
Ambient temperature (storage/transport)	°C	-20 ... +60	-20 ... +60
Permissible humidity (operation)	%	85 (at 40 °C, non-condensing)	
Assembly		Panel assembly	
Cooling		Convection (fanless)	
Degree of protection – front		IP66	IP66
Degree of protection – rear		IP20	IP20



Machine operator panels

VAM15, VAM21



The convenient VAM machine operator panels optimize individual operating concepts of the machine. These additional components are exactly matched to our visualization devices and ensure safe operation with their industry-compatible design. The VAM15 machine operator panel is suitable for 15.6" units and VAM21 is suitable for 21" units.

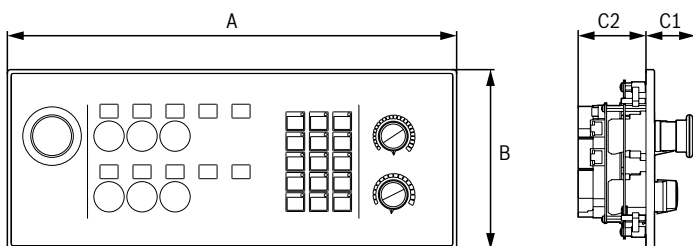

Dimensions			
Type		VAM15.1	VAM21.1
A	mm	422	350
B	mm	169	169
C1	mm	47	47
C2	mm	64	64
Mass	kg	2.1	1.9

■ For more information, please visit: www.boschrexroth.com/cat-vam

Technical specifications			
Type		VAM15.1	VAM21.1
Operation			
Type		Machine operator panels for standard machine tools	
Function buttons		15 short-stroke keys, 1 emergency off button, 1 feed system override rotary switch, 1 spindle override rotary switch, 6 long-travel keys, 5 mounting cutouts for switching elements	
Interfaces			
Fieldbus system		1 x Sercos (2 x RJ45)	1 x Sercos (2 x RJ45)
Electrical data			
Logic supply U_L	V DC	24	24
	A	≤ 0.5	≤ 0.5
Input/output power supply U_M	V DC	24	24
	A	≤ 0.5	≤ 0.5
Mechanical tests			
Vibration resistance	g	1	1
Shock resistance	g	15	15
General data			
Colors		RAL 7024 Graphite gray	
Degree of protection – front		IP54	IP54

Machine operator panels

VAM81, VAM82



The convenient VAM machine operator panels optimize individual operating concepts of the MTX micro CNC system. These additional components are precisely matched to the VDP81 and VDP82 displays and ensure safe operation with their industry-compatible design. The VAM81 machine operator panel is suitable for the VDP81 display and VAM82 is suitable for the VDP82 display.

- ▶ **Machine operator panel for installation**
- ▶ **Optimum man-machine interface**
- ▶ **CNC system MTX micro**
- ▶ **Designed for rough industrial applications**
- ▶ **Ideal for CNC machines for drilling, turning, milling, grinding, gear cutting**

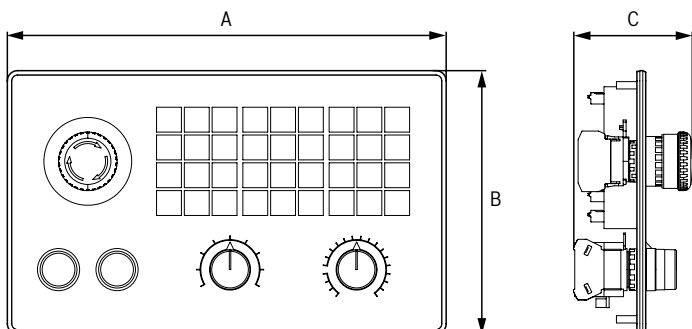

Dimensions			
Type		VAM81.1	VAM82.1
A	mm	420	300
B	mm	140	180
C	mm	25	25
Mass	kg	1.1	1.1

■ For more information, please visit: www.boschrexroth.com/cat-ae

Technical specifications			
Type		VAM81.1	VAM82.1
Operation			
Type		Key operation	
Number of machine keys		36	36
Additional operating elements		1 x emergency stop; 2 x pushbutton, 2 x override	
Interfaces			
Type		1 x interface for mobile handwheel	
		1 x interface for additional inputs	
		1x interface for additional outputs	
Electrical data			
Supply voltage	V DC	24	24
	%	±20	±20
Power consumption	W	8	8
General data			
Color		RAL 7024 Graphite gray	
Ambient temperature (operation)	°C	0 ... +45	0 ... +45
Permissible humidity (operation)	%	≤ 75, EN 61131-2	≤ 75, EN 61131-2
Degree of protection – overall		IP20	IP20
Degree of protection – front		IP54	IP54

Embedded controls

The wide portfolio of scalable control hardware flexibly extends centralized and decentralized automation topologies. Well-developed hardware specially designed for complex processes in conjunction with the open software

architecture form the ideal platform for customized motion solutions and simple integration into your automation environment.

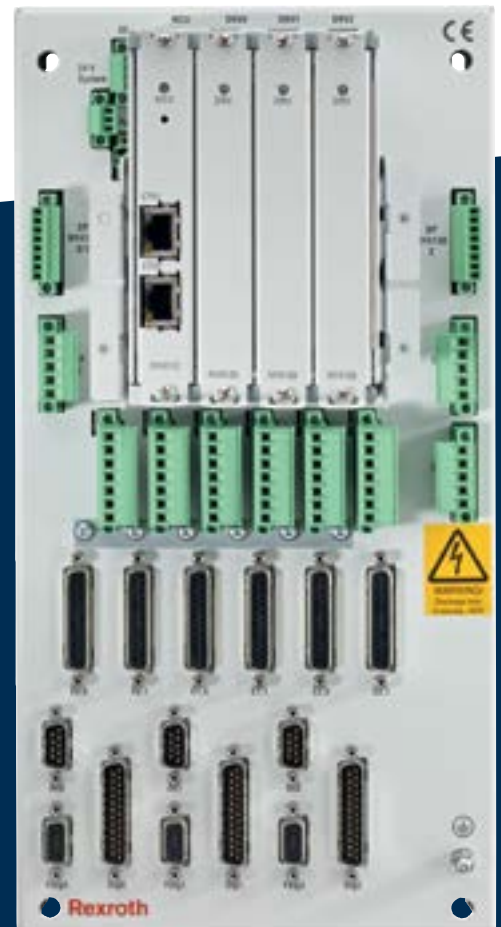

XM	96
XM controls – XM21, XM22	98
XM control – XM42	100
XM extension modules – communication – XFE01.1-FB	102
XM extension modules – Safety-CPU – XFE01.1-SY	104
YM	106
YM housings – NYS04.x-ST	108
YM control modules – NYM04.1-MCU	110
YM drive modules – NYM04.1-xxx	112

XM

The XM series of compact embedded controls provides the latest hardware technology in a robust enclosure design. It combines the excellent real-time capability of the Sercos automation bus and the flexibility of the I/O series S20 into a modular and complete automation system for all factory automation applications.

Information on other embedded control components (CML, CFL) is available at www.boschrexroth.com/automation.

- ▶ **Scaled in power and scope of functions based on the latest chip technology**
- ▶ **Robust design with extended temperature range**
- ▶ **Simple, flexible I/O integration**
- ▶ **Optionally expandable with extension modules (communication, safety)**
- ▶ **Degree of protection IP20**



▶ **XM controls XM21/22**

The XM21/XM22 controls are robust industrial controls in the medium power range.



▶ **XM control XM42**

The XM42 embedded control is the functional all-rounder for machine optimization in the high-end segment.



► XFE extension modules XFE

The XFE extension modules are connected to the XM embedded control via the bus socket module and extend it by additional communication interfaces such as Sercos (cross communication), PROFINET, EtherNet/IP, DeviceNet and PROFIBUS. The safety module extends the standard XM control hardware to form the safety control SafeLogic.

XM controls

XM21, XM22



The XM21 and XM22 embedded controls are available for a variety of PLC and motion applications. The local connection of the I/O modules S20 extends the control flexibly to form a high-performance process connection. Decentralized I/Os, drives and other system periphery are connected as standard via Sercos. Optional extension modules open up further integration options. The control can also be used flexibly at high temperature ranges. A specially certified variant of the XM22 control is also suitable for use in marine and offshore applications.

- ▶ **Systems: ILC, MLC (Synchronized Motion, technology functions, robotics, hydraulics)**
- ▶ **On-board: Sercos master (Sercos, EtherCAT I/O)**
- ▶ **Gbit Ethernet, USB host and device, SD card slot, diagnostic LED**
- ▶ **Modular expansion options with extension and I/O modules**
- ▶ **Simple commissioning with First Touch web server**
- ▶ **Robust hardware design for industrial as well as marine and offshore applications**

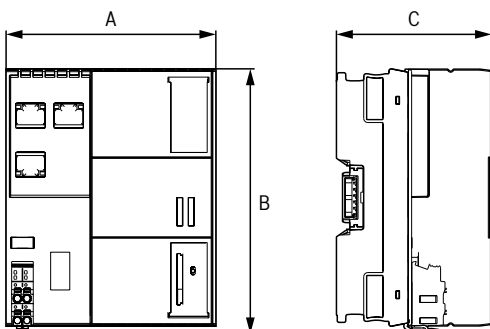

Dimensions			
Type		XM21	XM22
A	mm	100	100
B	mm	126.3	126.3
C	mm	74.1	74.1
Mass	kg	0.48	0.48

■ For more information, please visit: www.boschrexroth.com/cat-xm

Technical specifications				
Type		XM21		XM22
Processor				
CPU		Intel Atom E620		Intel Atom E660
Clocking	MHz	600		1 300
Memory				
Installed hard disk	GB	1		1
Task/application (RAM)	MB	512		512
Remanent memory	kB	128		128
Extensions				
Functional extension		3 x extension modules XFE01 with bus socket module XA-BS02		
I/O extension		Connection of S20 modules via bus socket module XA-BS01 or XA-BS02		
Interfaces				
Type	Engineering port (RJ45)		1 x Gbit Ethernet	1 x Gbit Ethernet
	USB		1x USB host	1x USB host
			1x USB device	1x USB device
	SD card		1 x slot for SD card	1 x slot for SD card
		GB	1	1
Fieldbus system and safety	On-board (2 x RJ45)		Sercos (master)	Sercos (master)
			Alternative: EtherCAT I/O (master)	Alternative: EtherCAT I/O (master)
	Via extension modules		Sercos (cross communication)	Sercos (cross communication)
			PROFINET RT (controller/device)	PROFINET RT (controller/device)
			EtherNet/IP (scanner/adapter)	EtherNet/IP (scanner/adapter)
			PROFIBUS DP (master/slave)	PROFIBUS DP (master/slave)
	Safe Logic	Safe Logic		
Electrical data				
Supply voltage ¹⁾	V DC	24		24
	%	-25/+30		-25/+30
Certificates				
Norms and Standards		CE, UL, CSA, RoHS2		CE, UL, CSA, RoHS2
Marine and Offshore ²⁾		-		DNV-GL (Det Norske Veritas, Germanischer Lloyd)
		-		ABS (American Bureau of Shipping)
		-		BV (Bureau Veritas)
		-		RINA (Registro Italiano Navate)
		-		LR (Lloyd's Register)
		-		BSH (Federal Maritime and Hydrographic Agency)
Mechanical tests				
Vibration resistance	g	5		5
Shock resistance	g	30		30
General data				
Ambient temperature (operation)	Without fan	°C	-25 ... +60	-25 ... +60
Storage temperature		°C	-30 ... +85	-30 ... +85
Permissible humidity (operation)	As per DIN EN 61131-2	%	5 ... 95	5 ... 95
Degree of protection			IP20	IP20
Operating height		m	4 700	4 700
Protection category				Class III

¹⁾ Including all tolerances, including ripple

²⁾ Available for XM2201

XM control

XM42



The XM42 is the high-performance control from Bosch Rexroth and is available as a functional all-rounder for various applications such as PLC, motion and CNC tasks. The local connection of the modules of the IP20 I/O system S20 extends the control flexibly for high-performance process connection. The additional on-board interfaces also enlarge the options for integration.

- ▶ **Systems: ILC, MLC, MTX**
- ▶ **On-board: Sercos master (Sercos, EtherCAT I/O)**
- ▶ **On-board: Multi-Ethernet (PROFINET, EtherNet/IP)**
- ▶ **Gbit Ethernet, USB host and device, SD card slot, diagnostic LED**
- ▶ **Real-time-capable I/O processing**
- ▶ **Modular expansion options with extension and I/O modules**
- ▶ **Simple commissioning with First Touch web server**
- ▶ **State-of-the-art chip technology**

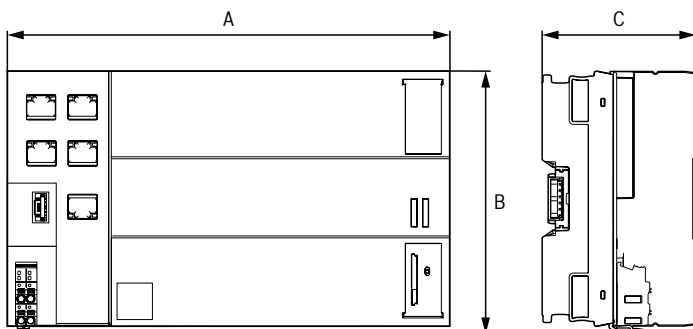

Dimensions		
Type		XM42
A	mm	200
B	mm	126.3
C	mm	74.1
Mass	kg	1.2

■ For more information, please visit: www.boschrexroth.com/cat-xm

Technical specifications			
Type		XM42	
Processor			
CPU		Intel Core i, Dual-Core, 6th generation	
Clocking	GHz	2.3	
Memory			
Installed hard disk	GB	4	
Task/application (RAM)	GB	2	
Remanent memory	MB	4	
Extensions			
Functional extension		3 x extension modules XFE01 with bus socket module XA-BS03	
I/O extension		Connection S20 modules with bus socket module XA-BS03	
Interfaces			
Type	Engineering port (RJ45)		1 x Gbit Ethernet
	USB		1x USB host
			1x USB device
	SD card		1 x slot for SD card
GB		4	
Fieldbus system and safety	On-board (2 x RJ45)		Sercos (master)
			Alternative: EtherCAT I/O (master)
	On-board (2 x RJ45)		PROFINET RT (controller/device)
			Alternative: EtherNet/IP (scanner/adapter)
	Via extension modules		Sercos (cross communication)
			PROFINET RT (controller/device)
			EtherNet/IP (scanner/adapter)
		PROFIBUS DP (master/slave)	
		Safe Logic	
Electrical data			
Supply voltage ¹⁾	VDC	24	
	%	-25/+30	
Mechanical tests			
Vibration resistance	g	1	
Shock resistance	g	15	
General data			
Ambient temperature (operation)	Without fan	°C	-25 ... +50
	With fan	°C	-25 ... +60
Storage temperature		°C	-25.... +70
Permissible humidity (operation)	As per DIN EN 61131-2	%	+5.... 95
Degree of protection			IP20
Operating height		m	Up to 3 000
Protection category			Class III

¹⁾ Including all tolerances, including ripple

XM extension modules – communication

XFE01.1-FB



With the XFE01.1-FB extension modules, it is possible to extend an XM control with additional communication interfaces. The extension modules can easily be attached to the control.

- ▶ **Sercos (cross communication)**
- ▶ **RT Ethernet (PROFINET, EtherNet/IP)**
- ▶ **PROFIBUS**
- ▶ **Degree of protection IP20**

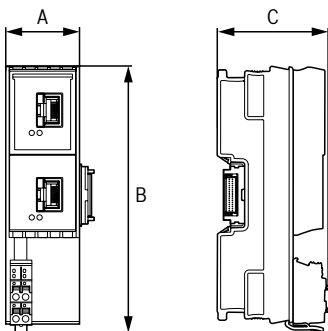

Dimensions		XFE01.1-FB-01	XFE01.1-FB-03	XFE01.1-FB-04	XFE01.1-FB-10	XFE01.1-FB-11
Type						
A	mm	35	35	35	35	35
B	mm	126.3	126.3	126.3	126.3	126.3
C	mm	52	52	52	52	52
Mass	g	120	120	120	120	120

■ For more information, please visit: www.boschrexroth.com/cat-xfe

Technical specifications						
Type		XFE01.1-FB-01	XFE01.1-FB-03	XFE01.1-FB-04	XFE01.1-FB-10	XFE01.1-FB-11
Interfaces						
Fieldbus system		Sercos (cross communication)	PROFINET RT (controller/device)	PROFINET RT (device)	PROFIBUS DP (master/slave)	PROFIBUS DP (slave)
		–	EtherNet/IP (scanner/adapter)	EtherNet/IP (adapter)	–	–
Electrical data						
Supply voltage ¹⁾	V DC	24	24	24	24	24
	%	-25/+30	-25/+30	-25/+30	-25/+30	-25/+30
Mechanical tests						
Vibration resistance	g	5	5	5	5	5
Shock resistance	g	30	30	30	30	30
General data						
Ambient temperature (operation)	°C	-25 ... +60	-25 ... +60	-25 ... +60	-25 ... +60	-25 ... +60
Permissible humidity (operation)	As per DIN EN 61131-2 %	5 ... 95	5 ... 95	5 ... 95	5 ... 95	5 ... 95
Degree of protection		IP20	IP20	IP20	IP20	IP20

¹⁾ Including all tolerances, including ripple

XM extension modules – Safety-CPU

XFE01.1-SY



The XFE extension modules are connected to the XM control using a bus socket module. The safety module extends the standard XM control hardware to form the safety control SafeLogic.

- ▶ **Extension of the control hardware to form the safety control SafeLogic**
- ▶ **Safety-CPU for two-channel evaluation of the safety application**
- ▶ **Multi-safety master Sercos (CIP Safety on Sercos) and PROFIsafe**
- ▶ **Internal memory card for firmware and safety application**
- ▶ **Degree of protection IP20**

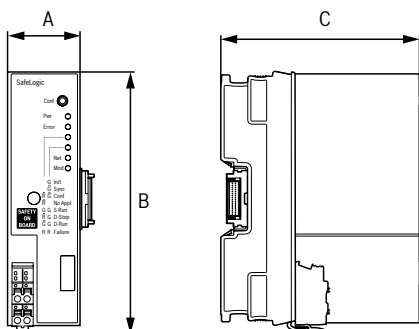

Dimensions		
Type	XFE01.1-SY-01	
A	mm	35
B	mm	126.1
C	mm	95.8
Mass	g	200

■ For more information, please visit: www.boschrexroth.com/cat-xfe

Technical specifications			
Type	XFE01.1-SY-01		
Functions			
Dual-channel safety control		Yes	
Multi-master, connection via XM		Sercos (CIP safety on Sercos), PROFIsafe	
Safety-related parameters			
Safety integrity level as per IEC 61508		SIL 3	
Safety integrity level as per EN 62061		SILCL 3	
Category as per EN ISO 13849-1		Category 4	
Performance level as per EN ISO 13849-1		PL e	
PFHd as per EN ISO 13849		$3.9 \cdot 10^{-9}$	
T _M (service life) as per EN ISO 13849		20 A	
Electrical data			
Supply voltage ¹⁾	V DC	24	
	%	-15/+20	
Power consumption	W	≤ 3	
Mechanical tests			
Vibration resistance ²⁾	g	5	
Shock resistance ³⁾	g	30	
General data			
Ambient temperature (operation)	°C	+5 ... +55	
Ambient temperature (storage)	°C	-40 ... +85	
Permissible humidity (operation)	No condensation	%	10 ... 95
Degree of protection			IP20

¹⁾ Including all tolerances, including ripple

²⁾ 11 ms, as per EN 60068-2-6

³⁾ 9 ... 0 Hz, as per EN 60068-2-27

YM

The YM embedded control is based on a scalable control platform with housing versions, control and drive modules. The modular multi-axis control combines the entire control and drive hardware in an extremely compact enclosure. Connections and wiring are factors that are often connected with considerable hidden costs for a machine. Cables from all components of the machine (motors, encoders, sensors, relays, switches) are usually connected to the control via distributor terminals. Most control systems require both external drive modules and I/O units. YM is not part of the sensible wiring – this reduces costs, saves space and ensures maximum machine availability.

- ▶ **Compact design for reduced installation space**
- ▶ **Compact size**
- ▶ **Integrated motion control**
- ▶ **Drive modules, I/O interfaces**
- ▶ **Scalable solutions thanks to modular design**



▶ **YM housing NSYS04**

The YM housings are extremely compact and available in versions for two to ten motors. They contain slots for control and drive modules.

Motors, encoders and I/O modules are connected directly to the housing.



► **YM control module N YM04.1-MCU**

The control module is the core of the motion control system. In addition, it is the platform for the automation software MPC or FTS which can be loaded to the control.



► **YM drive modules N YM04.1-xxx**

All drive modules are characterized by the integration of digital and analog I/O modules.

YM housing

NYS04.x-ST



The extremely compact YM housings are available in versions for two to ten motors and contain slots for the control and drive modules. Motors, encoders and I/O can be connected directly to the housing.

For MPC applications, the enclosures NY4013, NY4023, NY4033, NY4043 and NY4053 can be used and for the flexible transport system FTS, the housings NY4074, NY4079 with integrated FTS encoder electronics are provided.

- ▶ **Reduced space requirement thanks to compact design**
- ▶ **Motion control, drive modules, I/O interfaces already integrated**
- ▶ **Modular design enables scalable solutions**

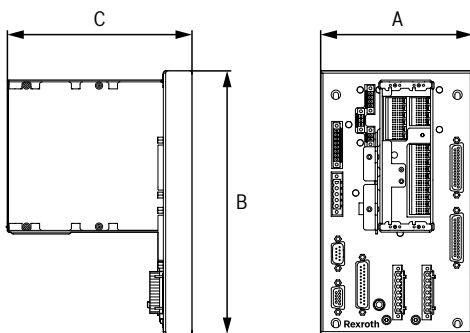

Dimensions		NYS04.2-ST-01-ULNN-NY4013	NYS04.2-ST-02-ULNN-NY4023	NYS04.2-ST-03-ULNN-NY4033	NYS04.2-ST-04-ULNN-NY4043	NYS04.2-ST-05-ULNN-NY4053	NYS04.2-ST-02-LMSN-NY4074	NYS04.1-ST-01-LMS-SERCOS-NY4079
A	mm	130	180	183	208	238	225	170
B	mm	225	240	353.5	353.5	353.5	270	200
C	mm	157.9	157.9	157.9	157.9	157.9	162.4	162.4

■ For more information, please visit: www.boschrexroth.com/cat-ym

Technical specifications							
Type	NYS04.2-ST-01-ULNN-NY4013	NYS04.2-ST-02-ULNN-NY4023	NYS04.2-ST-03-ULNN-NY4033	NYS04.2-ST-04-ULNN-NY4043	NYS04.2-ST-05-ULNN-NY4053	NYS04.2-ST-02-LMSN-NY4074	NYS04.1-ST-01-LMS-SERCOS-NY4079
Plug-in slot 1 for MCU modules	NY4110, NY4112, NY4114	NY4110, NY4112, NY4114	NY4110, NY4112, NY4114	NY4110, NY4112, NY4114	NY4110, NY4112, NY4114	NY4110, NY4112, NY4114	NY4110, NY4112, NY4114
Plug-in slot 2 for drive or communication module	NY4120, NY4130, NY4140, NY4150/10	–	–	–	–	–	–
Plug-in slot 2 for drive or communication module and 3 for drive module	–	NY4120, NY4130, NY4140, NY4150/10	–	–	–	–	–
Plug-in slot 2 for drive or communication module and 3, 4 for drive modules	–	–	NY4120, NY4130, NY4140, NY4150/10	–	–	–	–
Plug-in slot 2 for drive or communication module and 3, 4, 5 for drive modules	–	–	–	NY4120, NY4130, NY4140, NY4150/10	–	–	–
Plug-in slot 2 for drive or communication module and 3, 4, 5, 6 for drive modules	–	–	–	–	NY4120, NY4130, NY4140, NY4150/10	–	–
Plug-in slot 2 and 3 for drive modules	–	–	–	–	–	NY4120/10	–
Plug-in slot 2 for communication module	–	–	–	–	–	–	NY4150/10
Suitable for automation software	MPC	MPC	MPC	MPC	MPC	FTS	FTS

YM control modules

NYM04.1-MCU



Three control modules are available for the YM embedded control: NY4110, NY4112 and NY4114.

NY4110 and NY4112 differ in communication (Firewire for NY4110 and Ethernet for NY4112). NY4114 offers higher performance and functionality. It is based on a Linux operating system for user programs. The development environment for the user software is Eclipse.

- ▶ **The control module is the core of the motion control system. It is also the platform for automation software that can be loaded into the control.**
- ▶ **NY4110/NY4112: no on-board operating system, limited support for on-board user software**
- ▶ **NY4114: powerful dual-core processor with 1 GB flash and 1 GB RAM, Linux operating system**

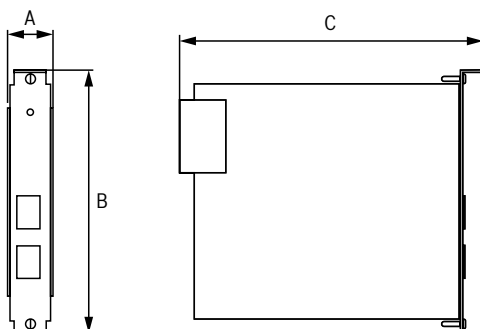

Dimensions				
Type		NYM04.1-MCU-NNNN-NY4110	NYM04.1-MCU-ETHER-NY4112	NYM04.1-MCU-ETHER-NY4114
A	mm	20	20	20
B	mm	130	130	130
C	mm	150	150	150

■ For more information, please visit: www.boschrexroth.com/cat-ym

Technical specifications				
Type		NYM04.1-MCU-NNNN-NY4110	NYM04.1-MCU-ETHER-NY4112	NYM04.1-MCU-ETHER-NY4114
Board type		MCU (motion control unit)	MCU (motion control unit) with Ethernet	
Position in the housing		Always first slot		
Interfaces		3 ¹⁾	2 ²⁾	3 ²⁾
Supply voltage	V	24	24	24
Voltage supply		Insulated for on-board and drive logic		
Cycle frequency		1, 2, 4 or 8 kHz		
Axis control		Up to 12 axes		
I/O		2 inputs: Service mode and quick-stop mode		

¹⁾ IEEE1394B (3 x STP)

²⁾ Ethernet (CAT5)

YM drive modules

NYM04.1-xxx



The drive modules of the YM embedded control make it possible to configure a tailor-made control. Depending on the particular application and the motors used, the optimum drive module can be selected. If more motor rating is required, the NY4150 communication module can be used, which allows for additional IndraDrive drives.

- ▶ **All drive modules are characterized by the integration of digital and analog I/Os.**
- ▶ **Performance levels NY4120, NY4120/10 and NY4140 also have an integrated temperature and overvoltage control.**

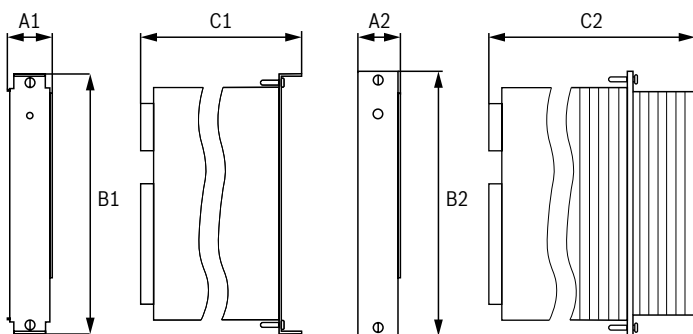

Dimensions							
Type		NYM04.1-2PW-NNNN-NY4120	NYM04.1-2PW-LMS-NY4120/10	NYM04.1-2LD-NNNN-NY4130	NYM04.1-1HV-NNNN-NY4140	NYM04.1-SE3-MAST-NY4150/10	NYM04.1-DIG-IO-NY4199
A1, A2	mm	20	20	20	20	20	45
B1, B2	mm	130	130	130	130	130	75
C1, C2	mm	150	150	172	150	150	–

■ For more information, please visit: www.boschrexroth.com/cat-ym

Technical specifications						
Type		NYM04.1-2PW-NNNN-NY4120	NYM04.1-2PW-LMS-NY4120/10	NYM04.1-2LD-NNNN-NY4130	NYM04.1-1HV-NNNN-NY4140	NYM04.1-SE3-MAST-NY4150/10
Board type		PWM drive module (pulse-width modulation)	PWM drive module (pulse-width modulation)	Low-power DC drive module	PWM high-voltage drive module	Sercos master module
Number of axes		2	2	2	1	≤ 8 ¹⁾
Motor type		Brushless DC/AC servo motors	Linear motor for FTS	–	Brushless DC/AC servo motors	–
		DC motors with brushes	–	DC motors with brushes	DC motors with brushes	–
		2-phase stepper motor	–	–	–	–
Supply voltage range	V	15 ... 75	15 ... 75	≥ +15/-15, ≤ +26/-26	48 ... 150	–
PWM frequency	kHz	16 ... 96	16 ... 96	–	16 ... 32	–
Output voltage	V	15 ... 75	15 ... 75	0 ... 48	48 ... 150	–
Rated current	A	7	7	–	7	–
	A	–	–	1 A for +26 V/-26 V, 2 A for +15 V/-15 V	–	–
Peak current		14 A per axis, 22 A per drive	14 A per axis, 22 A per drive	Max. 4 A	14 A	–
Current control loop		Standard (on-board)	Standard (on-board)	–	Standard (on-board)	–
Position controller		Standard (on-board)	Standard (on-board)	Standard (on-board)	Standard (on-board)	–
Temperature monitoring		Standard (on-board)	Standard (on-board)	Standard (on-board)	Standard (on-board)	–
Overcurrent detection		Standard (on-board)	Standard (on-board)	–	Standard (on-board)	–
S0/S90 encoder cable break detection		Standard (on-board)	–	Standard (on-board)	Standard (on-board)	–

¹⁾ IndraDrive C or Cs

NYM04.1-xxx

■ For more information, please visit: www.boschrexroth.com/cat-ym

Technical specifications						
Type	NYM04.1-2PW- NNNN-NY4120	NYM04.1-2PW- LMS-NY4120/10	NYM04.1-2LD- NNNN-NY4130	NYM04.1-1HV- NNNN-NY4140	NYM04.1-SE3- MAST-NY4150/10	
I/O	Inputs	6 x RS422 encoder inputs for each axis (2 x S0, S90 and Index)	–	6 x RS422 encoder inputs for each axis (2 x S0, S90 and Index)	6 x RS422 encoder inputs for each axis (2 x S0, S90 and Index)	–
	Digital inputs	8	8	10	8	–
	Digital outputs	4	4	4	–	–
	Analog Inputs	2 (12 bits)	–	2 (16 bits)	1 (12 bits)	–
	Analog outputs	2 (16 bits)	–	2 (16 bits)	2 (16 bits)	–
	Further inputs	6 x digital 5 V inputs, for use as Hall input, S0/S90 counter input or digital input	–	6 x digital 5 V inputs, for use as counter input or digital input	3 x digital 5 V inputs, for use as Hall input, S0/S90 counter input or digital input	–
Encoder interfaces, standard (on-board)	Digital S0/S90 with index pulse	–	–	Digital S0/S90 with index pulse	Digital S0/S90 with index pulse	–
	Absolute or incremental (Rexroth MSM motors)	–	–	–	Absolute or incremental (Rexroth MSM motors)	–
	EnDat 2.2	–	–	EnDat 2.2	EnDat 2.2	–
Encoder interfaces, optional (for SinCos-special module NY4199)	EnDat 2.1	–	–	EnDat 2.1	EnDat 2.1	–
	Hiperface®	–	–	Hiperface®	Hiperface®	–
	SinCos	–	–	SinCos	SinCos	–

Technical specifications

Type	NYM04.1-DIG-IO-NY4199
Board type	Plug-in module
Board function	Dual SinCos input and interpolation module to support 2 axes
Installation location	Assembly to NY4120, NY4130, NY4140 drive modules
Input frequency	Max. 400 kHz
Interpolation factor	You can choose between 4 and 4 096 for a full signal period
Input voltage	1 V _{tt} absolute value in bandwidths of 0 ... 5 V

I/O systems

The modular, compact device concept of the I/O systems from Bosch Rexroth enables maximum flexibility for the economical realization of individual machine concepts.

The I/O modules are robust in design and mechanics, easy to handle and fast in reaction time and installation – both for control cabinet and field installation.

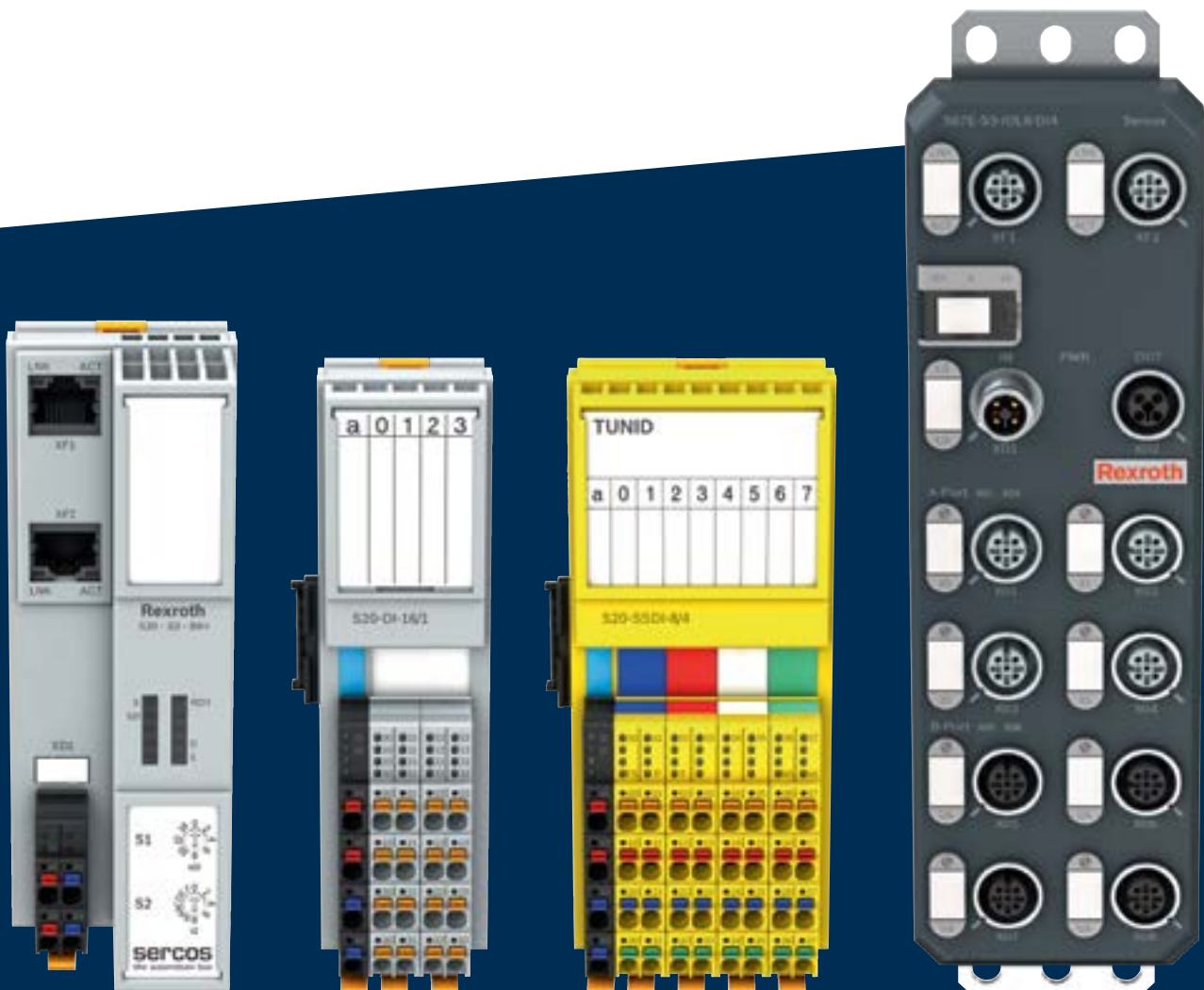

S20	118
General technical specifications and dimensions – S20	120
Fieldbus coupler – S20-x-BK	122
Analog input modules – S20-AI-x	124
Analog input module – S20-SGI-2	126
Analog output modules – S20-AO-x	128
Analog input/output module – S20-AIAO-2	130
Digital input modules – S20-DI-x	132
Digital output modules – S20-DO-x	134
Digital input/output modules – S20-DI-16/4-DO-8/3-HS, S20-DIDO-8/1	136
Relay module – S20-DOR-4/2-220-AC	138
Temperature modules – S20-AI-x-xTx	140
Communication modules – S20-DALI-2-PWR, S20-RS-UNI, S20-KNX-1	142
Technology modules – Incremental value encoders S20-CNT-INC-2/2, S20-INC-2	144
Technology modules – SSI interface – S20-SSI-AO-1/1, S20-AI6-AO2-SSI2	146
Technology module – pulse-width modulation – S20-PWM-2/2, S20-PWM-4T	148
Technology module – power measurement – S20-PM-EF	150
Boost module logic supply – S20-PWR	152
Safety related digital input modules – S20-SSDI-8/4, S20-PSDI-8/4	154
Safety related digital output modules – S20-SSDO-8/3, S20-PSDO-8/3	156
S67E	158
Communication modules – S67E-x-IOL8-DI4-M12-6P	160

S20

The S20 system connects fast sensors and actuators to the network via the system bus and the bus coupler. It is compatible with the most common automation buses. The bus coupler is the connection between the S20 participants and the Sercos automation bus, PROFINET, PROFIBUS, EtherNet/IP, EtherCAT or standard Ethernet. The modularly expandable I/O modules each require an update time of only 1 μ s. This means that shortest update times can be achieved, even at the maximum expansion stage with up to 63 I/O modules per bus coupler. Faster acquisition and transfer of measurement results improves the process control. This makes shorter cycle times and higher precision possible.

Information on other IP20 I/O components (inline) is available at www.boschrexroth.com/automation.

The S20 system is designed for robust use and has been tested in extensive continuous shock tests. Adjustable filter times improve the electromagnetic compatibility, and the reduced radiation ensures long-term durability. The toolless cable assembly simplifies the wiring and maintenance. In the event of an error, the user can simply remove the plug and change the electronics module.

- ▶ **Reliable acquisition of time-critical signals**
- ▶ **Robust in design and mechanics**
- ▶ **Easy handling**



- ▶ **Fieldbus coupler** form the first module of an S20 station and are the interface to the fieldbus system. The individual I/O modules can be connected to it.



- ▶ **Digital I/O modules** for connecting digital signals, such as pushbuttons, limit switches or proximity switches.

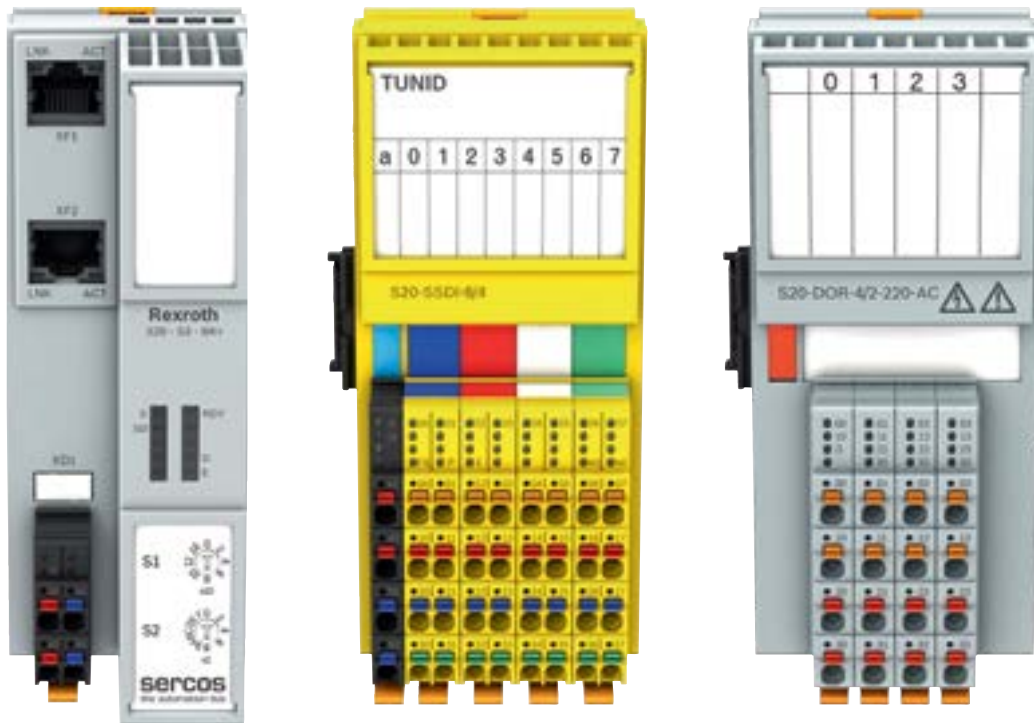

- **Analog I/O modules** enable the acquisition and output of analog signals from standard sensors and analog actuators.



- **Function modules** are used to solve special tasks, e.g. fast forward/backward counting, incremental data acquisition or communication connection. The portfolio includes:
- Technology modules
 - Relay modules
 - Temperature modules
 - Communication modules
 - Boost modules
 - Safety modules

S20

General technical specifications and dimensions

S20 with degree of protection IP20 is the flexibly scalable I/O system for shortest cycle times and highest precision and provides a real-time data flow between control and peripherals – no matter whether locally at the XM control or as decentralized I/O station.

- ▶ **Compact, modular and simple**
- ▶ **Extended temperature range**
- ▶ **Innovative assembly and installation concept**
- ▶ **Individually combinable modules**

■ For more information, please visit: www.boschrexroth.com/cat-s20

General technical specifications			
Type		S20-xxx-x....	
Color		RAL 7035 Light gray	
Ambient temperature (operation)	°C	-25 ... +60	
Ambient temperature (storage/transport)	°C	-40 ... +85	
Permissible humidity (operation)	No condensation	%	5 ... 95
Permissible air humidity (storage / transport)	No condensation	%	5 ... 95
Air pressure (operation)	Up to 3 000 m above sea level	kPa	70 ... 106
Air pressure (storage / transport)	Up to 3 000 m above sea level	kPa	70 ... 106
Operating height		Up to 3 000 m above sea level	
Degree of protection		IP20	
Installation position		As required (no temperature derating)	
Connection data			
Denomination		S20 connector	
Connection type		Push-in technology	
Stripped length	mm	8	
Interface local bus			
Connection type		Bus socket module	
Number		1	
Transfer rate	MBit/s	100	
Mechanical tests			
Vibration resistance	g	5	
Shock resistance	g	30	
Continuous shock resistance	g	10	

Dimensions

Design	1	2	3
A	45	53.6	35
B	125.9	126.1	126.1
C ¹⁾	74	54	54

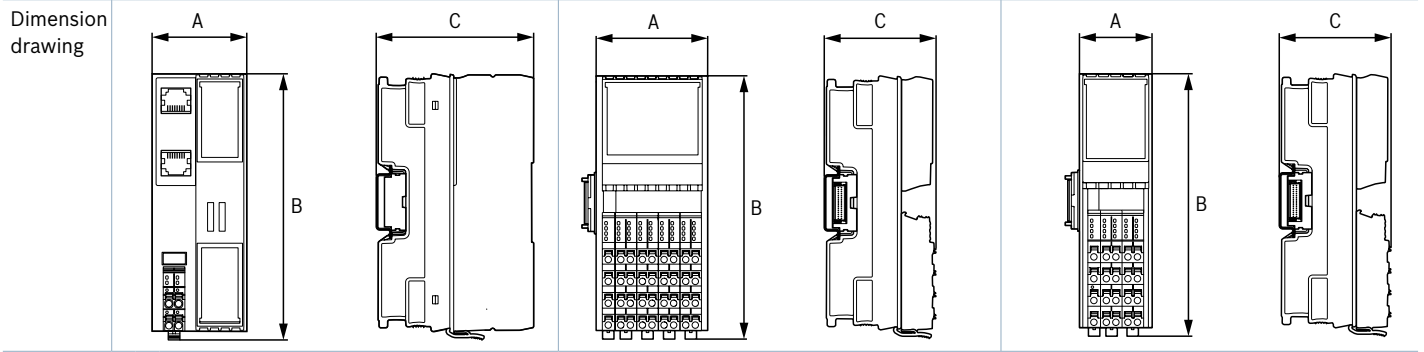

Design	4	5	6
A	53.6	35	53.6
B	129.9	129.9	126.1
C ¹⁾	54	54	54

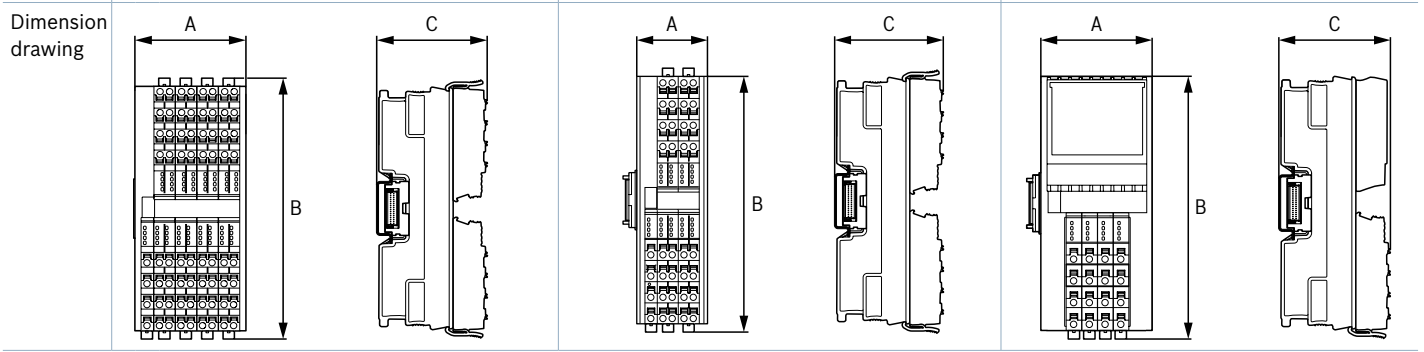

Design	7	8	9
A	35	53.6	35
B	126.1	126.1	126.1
C ¹⁾	54	65.5	54

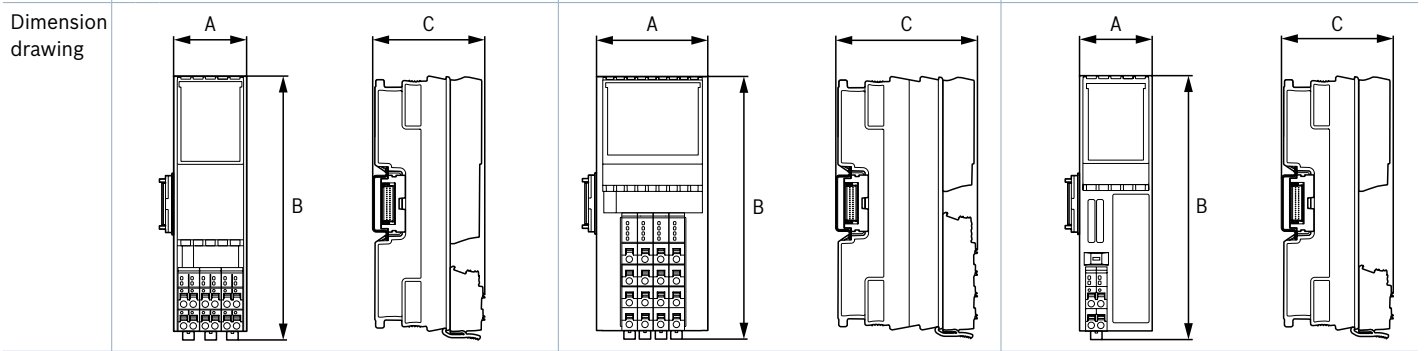

¹⁾ The depth applies when using a load rail TH 35-7.5 (as per EN 60715).

Fieldbus coupler S20-x-BK



The fieldbus coupler is designed for use within an automation network and is the connection to the S20 system. You can use the bus coupler to connect up to 63 S20 modules to an existing network.

- ▶ **Sercos, EtherCAT**
- ▶ **PROFINET, EtherNet/IP**
- ▶ **Ethernet, PROFIBUS**
- ▶ **Up to 63 additional S20 participants can be connected**
- ▶ **Diagnostic and status display**

■ For more information, please visit: www.boschrexroth.com/cat-s20-bc

Technical specifications								
Type		S20-S3-BK+	S20-EC-BK	S20-PN-BK+	S20-EIP-BK	S20-ETH-BK	S20-PB-BK	
Design ¹⁾		1	1	1	1	1	1	
Mass ²⁾	g	177	219.9	177	177	177	175	
Fieldbus interface								
Interface		Sercos	EtherCAT	PROFINET RT	EtherNet/IP	Ethernet	PROFIBUS	
Number of interfaces		2	2	2	2	2	1	
Connection type (auto-negotiation and auto-crossing)		RJ45 socket					D-SUB-9 socket	
Transfer rate	MBit/s	100 ³⁾	100 ³⁾	100 ³⁾	10/100 ⁴⁾	10/100 ⁴⁾	0.96 ... 12	
Transfer length	m	≤ 100	≤ 100	≤ 100	≤ 100	≤ 100	≤ 100	
Supply of the bus coupler								
Supply logic voltage U _L	V DC	24	24	24	24	24	24	
Logic voltage U _{Bus}	V DC	5	5	5	5	5	5	
Power supply to U _{Bus}	A	2	2	2	2	2	2	

¹⁾ Dimension drawings and dimensions, see page 121

²⁾ Including plug and bus socket module

³⁾ Full-duplex

⁴⁾ Semi or full-duplex (automatic detection, optionally manually adjustable)

Analog input modules

S20-AI-x



These modules are designed for use within an S20 station. They are used for the acquisition of analog signals.

- ▶ **Acquisition of analog signals**
- ▶ **Current and voltage measuring ranges**
- ▶ **4 or 8 channels**
- ▶ **Measured value display 16 bits**
- ▶ **Connection of the sensors in 2-wire technology**
- ▶ **Diagnostic and status display**

■ For more information, please visit: www.boschrexroth.com/cat-s20-ai

Technical specifications				
Type		S20-AI-8	S20-AI-4-I	S20-AI-4-U
Design ¹⁾		2	3	3
Mass ²⁾	g	204	145	145
Supply of the logic				
Logic voltage U_{Bus} ³⁾	V DC	5	5	5
Maximum current consumption from U_{Bus}	mA	130	150	150
Supply of peripherals				
Supply of analog modules U_A	V DC	24	24 ⁴⁾	24 ⁴⁾
Overvoltage protection			Electronic (35 V, 0.5 s)	
Inverse polarity protection			Polarity protection diode	
Analog inputs				
Number of analog inputs		≤ 8 ⁵⁾	≤ 4 ⁶⁾	≤ 4 ⁷⁾
Connection technology		2-wire technology (shielded, twisted pair)	2-wire, 3-wire, 4-wire technology (shielded)	
Current input signal	mA	0 ... 20, 4 ... 20, -20 ... 20	0 ... 20, 4 ... 20, -20 ... 20	–
Voltage input signal	V	0 ... 5, -5 ... 5, 0 ... 10, -10 ... 10	–	0 ... 5, -5 ... 5, 0 ... 10, -10 ... 10
A/D conversion time	μs	2	31.25	31.25
Measured value display	15 bits + sign	Bit	16	16
Process data update	μs	300	180	180
Input filter		30 Hz, 12 kHz and averaging (parameterizable)		
Precision		0.1 % (from measurement range end value with active averaging and 30 Hz filter)		

¹⁾ Dimension drawings and dimensions, see page 121

²⁾ Including plug and bus socket module

³⁾ Via bus socket module

⁴⁾ Supply of peripherals and sensor supply

⁵⁾ Differential inputs, voltage or current individually selectable

⁶⁾ Differential inputs, current

⁷⁾ Differential inputs, voltage

Analog input module

S20-SGI-2



This module is designed for use within an S20 station. It is used to evaluate strain gages (DMS), e.g. in weighing cells or load cells. The strain gages can be connected both in 6-wire and in 4-wire technology.

- ▶ **2 high-precision inputs for strain gages**
- ▶ **Current and voltage measuring ranges**
- ▶ **Manual, stepless parameters input**
- ▶ **Process data update can be set in steps between 200 μ s and 100 ms**
- ▶ **2-point adjustment**
- ▶ **Extended wire break detection**

■ For more information, please visit: www.boschrexroth.com/cat-s20

Technical specifications			
Type			S20-SGI-2
Design ¹⁾			3
Mass ²⁾		g	105
Supply of the logic			
Logic voltage U_{Bus} ³⁾		V DC	5
Maximum current consumption from U_{Bus}		mA	75
Supply of peripherals			
Supply of analog modules U_A		V DC	24
Overvoltage protection			Suppressor diode
Inverse polarity protection			Polarity protection diode
Analog inputs			
Number of analog inputs			2
Connection technology			4-wire, 6-wire technology (shielded, twisted pair)
Measured value display	15 bits + sign	Bit	32
Bridge difference U_d			Measurement range determined by selecting the parameter
Bridge voltage U_o		V	5
Characteristics	Infinitely parameterizable	$\mu\text{V/V}$	350 ... 6 500
Analog outputs			
Number of analog outputs			2
Current output signal	Per channel	mA	Max. 115
Voltage output signal		V	Typ. 5
Impedance	Per channel	Ω	> 43

¹⁾ Dimension drawings and dimensions, see page 121

²⁾ Including plug and bus socket module

³⁾ Via bus socket module

Analog output modules

S20-AO-x

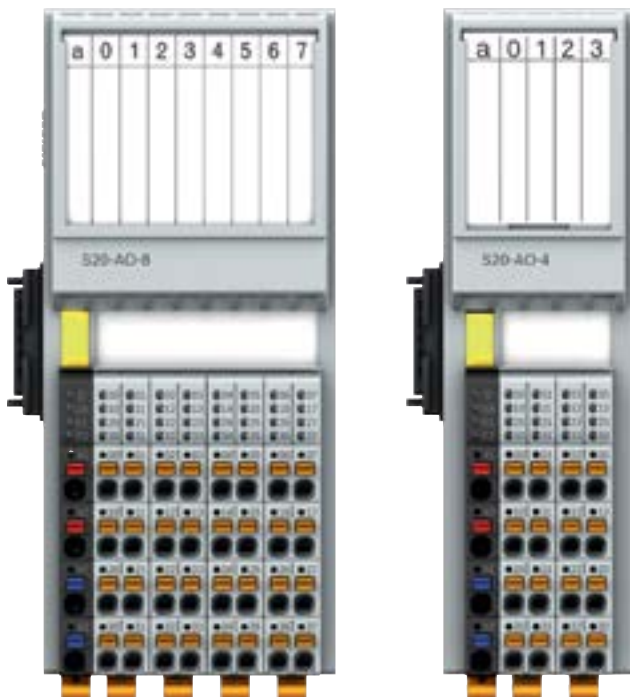

These modules are designed for use within an S20 station. They are used to output analog voltage and current signals.

- ▶ **4 or 8 analog bipolar outputs**
- ▶ **Current and voltage measuring ranges**
- ▶ **16-bit output value**
- ▶ **Protected against overload and short circuit**
- ▶ **Electronic nameplate**
- ▶ **Diagnostic and status display**

■ For more information, please visit: www.boschrexroth.com/cat-s20-ao

Technical specifications			
Type		S20-AO-4	S20-AO-8
Design ¹⁾		3	2
Mass ²⁾	g	145	260
Supply of the logic			
Logic voltage U_{Bus} ³⁾	V DC	5	5
Maximum current consumption from U_{Bus}	mA	150	130
Supply of peripherals			
Supply of analog modules U_A	V DC	24	24
Maximum current consumption from U_A	8 current channels, output 20 mA mA	110	235
Overvoltage protection		Electronic (35 V, 0.5 s)	
Inverse polarity protection		Polarity protection diode	
Analog outputs			
Number of analog outputs		4	8
Connection technology		2-wire technology (shielded, twisted pair)	
D/A conversion time	μs	5	5
Output value representation	15 bits + sign Bit	16	16
Process data update	μs	168	300
Permissible cable lengths	m	≤ 250	≤ 250
Short-circuit protection, overload protection		Electronic	
Analog outputs, current			
Current output signal	mA	0 ... 20, 4 ... 20	0 ... 20, 4 ... 20, -20 ... 20
Output load current output	Ω	≤ 500	≤ 500
Precision		Typ. 0.1 % (from the output range end value)	
Analog outputs, voltage			
Voltage output signal	V	0 ... 5, -5 ... 5, 0 ... 10, -10 ... 10	0 ... 5, -5 ... 5, 0 ... 10, -10 ... 10
Output load voltage output	kΩ	> 1	> 2
Precision		Typ. 0.1 % (from the output range end value)	

¹⁾ Dimension drawings and dimensions, see page 121

²⁾ Including plug and bus socket module

³⁾ Via bus socket module

Analog input/output module

S20-AIAO-2



This module is designed for use within an S20 station. It is used to acquire and output analog signals.

- ▶ **Aquisition and output of analog signals**
- ▶ **Current and voltage measuring ranges**
- ▶ **2 inputs, 2 outputs**
- ▶ **Measured value display 16 bits**
- ▶ **Connection of the sensors in 2-wire technology**
- ▶ **Diagnostic and status display**

■ For more information, please visit: www.boschrexroth.com/cat-s20-aiao

Technical specifications			
Type		S20-AIAO-2	
Design ¹⁾		3	
Mass ²⁾	g	200	
Supply of the logic			
Logic voltage U_{Bus} ³⁾	V DC	5	
Maximum current consumption from U_{Bus}	mA	150	
Supply of peripherals			
Supply of analog modules U_A	V DC	24	
Overvoltage protection		Electronic (35 V, 0.5 s)	
Transient protection		Suppressor diode	
Analog inputs			
Number of analog inputs ⁴⁾		2	
Connection technology		2-wire technology (shielded)	
Current input signal	mA	0...20, 4...20, -20...20	
Voltage input signal	V	0...5, -5...5, 0...10, -10...10	
A/D conversion time	μs	2	
Measured value display	15 bits + sign	Bit	16
Process data update		μs	150
Input filter		30 Hz, 12 kHz and averaging (parameterizable)	
Precision		0.1 % (from measurement range end value with active averaging and 30 Hz filter)	
Analog outputs			
Number of analog outputs		2	
Connection technology		2-wire technology (shielded, twisted pair)	
Current output signal	mA	0 ... 20, 4 ... 20, -20 ... 20	
Voltage output signal	V	0 ... 5, -5 ... 5, 0 ... 10, -10 ... 10	
Output value representation	15 bits + sign	Bit	16
Process data update		μs	150
Output load current output		Ω	≤ 500
Output load voltage output		kΩ	> 2
Precision		Typ. 0.1 % (from the output range end value)	
Short-circuit protection, overload protection		Electronic	

¹⁾ Dimension drawings and dimensions, see page 121

²⁾ Including plug and bus socket module

³⁾ Via bus socket module

⁴⁾ Differential inputs, voltage or current individually selectable

Digital input modules

S20-DI-x



These modules are designed for use within an S20 station. They are used to acquire digital signals. The filter times for the inputs can be adjusted to increase the interference immunity.

- ▶ **Acquisition of digital signals**
- ▶ **24 V DC, 2.4 mA**
- ▶ **1-wire, 2-wire, 3-wire and 4-wire technology**
- ▶ **Min. update time < 100 μ s, bus-synchronous**
- ▶ **Maximum input frequency: 5 kHz**
- ▶ **Electronic nameplate**
- ▶ **Diagnostic and status display**

■ For more information, please visit: www.boschrexroth.com/cat-s20-di

Technical specifications							
Type		S20-DI-16/1	S20-DI-16/1-HS	S20-DI-16/4	S20-DI-32/1	S20-DI-32/1-S	S20-DI-64/1
Design ¹⁾		3	3	4	2	5	4
Mass ²⁾	g	133	133	231	167	167	231
Supply of the logic							
Logic voltage U_{Bus} ³⁾	V DC	5	5	5	5	5	5
Maximum current consumption from U_{Bus}	mA	120	120	120	120	120	120
Supply of peripherals							
Supply of digital input modules U_i	V DC	24	24	24	24	24	24
Overvoltage / reverse polarity protection supply voltage		Electronic (35 V, 0.5 s)/parallel diode					
Sensor supply							
Maximum sensor total current per group	A	–	–	2	–	–	–
Digital inputs							
Number of digital inputs		16	16	16	32	32	64
Connection technology		1-wire technology		2-wire, 3-wire, 4-wire technology	1-wire technology		
Input description		As per EN 61131-2 type 1 and type 3					
Rated input voltage	V DC	24	24	24	24	24	24
Rated input current	mA	2.4	2.3	2.4	2.4	2.4	2.4
Input filter time	μs	< 100; 1 000; 3 000 (standard)	< 5	500 (standard); < 100	3 000 (standard); 1 000; < 100		
Process data update ⁴⁾	μs	< 100	< 5	–	–	–	< 100
Inverse polarity protection		Parallel diode (30 V, 5 s)		Electronic	Parallel diode (30 V, 5 s)		

¹⁾ Dimension drawings and dimensions, see page 121

²⁾ Including plug and bus socket module

³⁾ Via bus socket module

⁴⁾ Bus-synchronous

Digital output modules

S20-DO-x

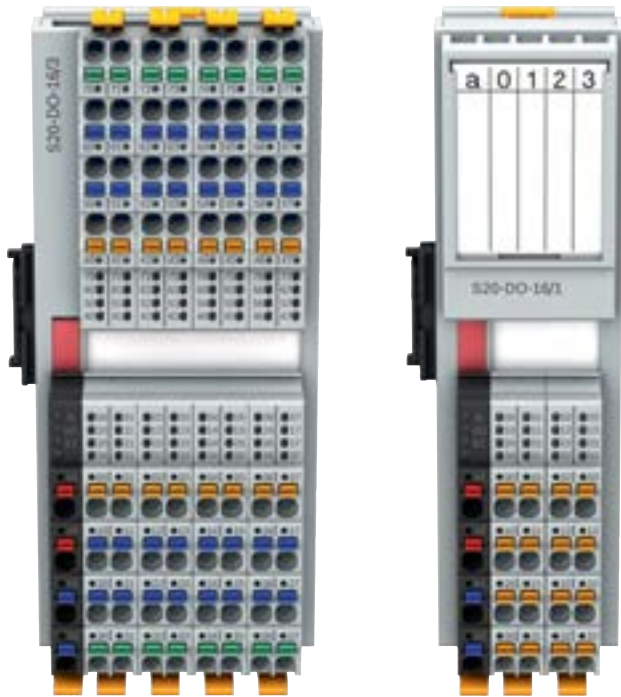

These modules are designed for use within an S20 station. They are used to output digital signals. The outputs are protected against short circuit and overload.

- ▶ **Output of digital signals**
- ▶ **24 V DC, 0.5 A or 2 A per channel**
- ▶ **Short-circuit-proof outputs**
- ▶ **1-wire, 2-wire or 3-wire technology**
- ▶ **Electronic nameplate**
- ▶ **Diagnostic and status display**

■ For more information, please visit: www.boschrexroth.com/cat-s20-do

Technical specifications						
Type		S20-DO-8/2-2A	S20-DO-16/1	S20-DO-16/3	S20-DO-32/1	S20-DO-64/1
Design ¹⁾		3	3	4	2	4
Mass ²⁾	g	136	134	234	191	260
Supply of the logic						
Logic voltage U_{Bus} ³⁾	V DC	5	5	5	5	5
Supply of peripherals						
Supply of digital output modules U_o	V DC	24	24	24	24	24
Overvoltage / reverse polarity protection supply voltage		Electronic (35 V, 0.5 s)/parallel diode				
Digital outputs						
Number of digital outputs		8	16	16	32	64
Connection technology		2-wire technology	1-wire technology	2-wire, 3-wire technology	1-wire technology	
Rated output voltage	V DC	24	24	24	24	24
Output current per channel	A	≤ 2	≤ 0.5	≤ 0.5	≤ 0.5	≤ 0.5
Output current per unit ⁴⁾	A	≤ 16	≤ 8	≤ 8	≤ 8	≤ 16
Signal delay upon activation	μs	≤ 150	≤ 100	≤ 100	≤ 150	≤ 100
Signal delay upon deactivation	μs	≤ 150 ⁵⁾	≤ 100 ⁶⁾	≤ 100 ⁶⁾	≤ 200 ⁷⁾	≤ 100
Overcurrent cutoff	A	> 2.8	> 0.7	> 0.7	> 0.7	> 0.7
Output current upon overvoltage in deactivated state	mA	< 1	< 1	< 1	< 1	< 1
Short-circuit protection, Overload protection of the outputs		Electronic				
Error signals to the higher-level control or computer system						
Error signal		Short-circuit/overload of digital outputs				

¹⁾ Dimension drawings and dimensions, see page 121

²⁾ Including plug and bus socket module

³⁾ Via bus socket module

⁴⁾ Secure externally

⁵⁾ For at least 100 mA load current

⁶⁾ For at least 50 mA load current

⁷⁾ With ohmic nominal load

Digital input/output modules

S20-DI-16/4-DO-8/3-HS, S20-DIDO-8/1

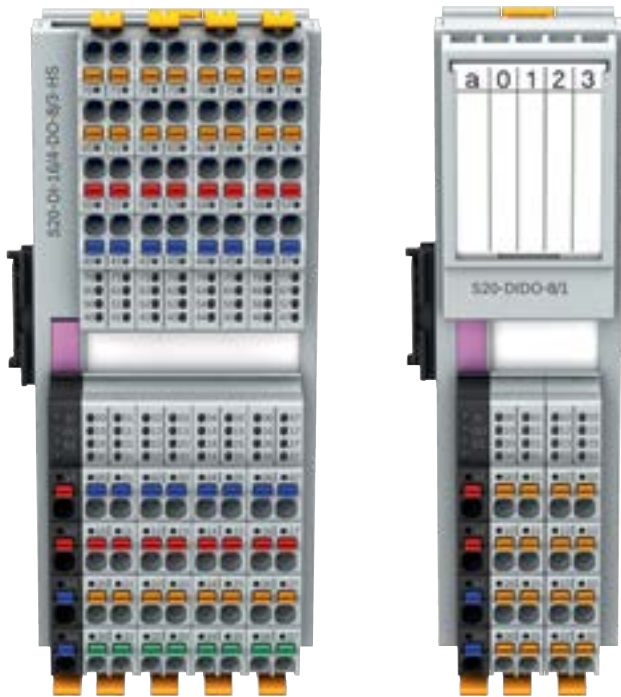

These modules are designed for use within an S20 station. They are used to acquire/output digital signals. The filter times for the inputs can be adjusted to increase the interference immunity. The outputs which are converted using half bridges are protected against short circuits and overload.

- ▶ **8 or 16 digital inputs and 8 digital outputs**
- ▶ **Synchronous process data processing**
- ▶ **Filter times can be adjusted in steps**
- ▶ **Electronic nameplate**
- ▶ **Diagnostic and status display**

■ For more information, please visit: www.boschrexroth.com/cat-s20-dido

Technical specifications			
Type		S20-DI-16/4-DO-8/3-HS	S20-DIDO-8/1
Design ¹⁾		4	3
Mass ²⁾	g	260	133
Supply of the logic			
Logic voltage U_{Bus} ³⁾	V DC	5	5
Maximum current consumption from U_{Bus}	mA	120	120
Supply of peripherals			
Supply of digital input modules U_i	V DC	24	24
Overvoltage / reverse polarity protection supply voltage		Via diode	Electronic (35 V, 0.5 s)/parallel diode
Sensor supply			
Number of groups		2	–
Maximum sensor total current per group	A	0.5	–
Short-circuit protection		Electronic, per group	–
Digital inputs			
Number of digital inputs		16	8
Connection technology		3-wire, 4-wire technology	1-wire technology
Input description		EN 61131-2 type 1 and 3	EN 61131-2 type 1 and 3
Rated input voltage	V DC	24	24
Rated input current	mA	2.4	2.4
Input filter time	µs	Can be set to four stages (tolerances in brackets): 7 (5 ... 8), 25 (8 ... 38), 750 (250 ... 1 100), 3 000 (1 000 ... 4 500)	< 100; 1 000; 3 000 (standard)
Process data update	µs	< 10 (synchronous)	< 100 ⁴⁾
Inverse polarity protection		Protected against reverse polarity up to 45 V	Parallel diode (30 V, 5 s)
Digital outputs			
Number of digital outputs		8	8
Connection technology		3-wire technology	1-wire technology
Rated output voltage	V DC	24	24
Output current per channel	mA	≤ 500	≤ 500
Output current per unit ⁵⁾	A	≤ 4	≤ 4
Load	Ω	–	≥ 10
Short-circuit protection, overload protection of the outputs			Electronic

¹⁾ Dimension drawings and dimensions, see page 121

²⁾ Including plug and bus socket module

³⁾ Via bus socket module

⁴⁾ Bus-synchronous

⁵⁾ Secure externally

Relay module

S20-DOR-4/2-220-AC

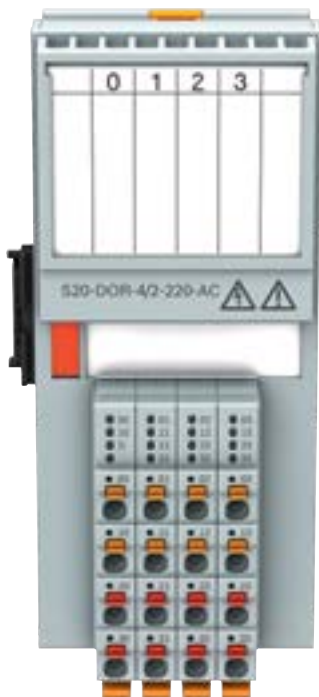

This module is designed for use within an S20 station. It has four relay make contacts that are independent from each other and potential-free. Low voltage and extra low voltage modules can be used directly next to each other within an S20 station.

- ▶ **Rated voltage up to 220 V DC and 230 V AC**
- ▶ **Potential-free connections for 4 actuators**
- ▶ **Rated current per output: 8 A**
- ▶ **Electronic nameplate**
- ▶ **Diagnostic and status display**

■ For more information, please visit: www.boschrexroth.com/cat-s20-dor

Technical specifications			
Type	S20-DOR-4/2-220-AC		
Design ¹⁾		6	
Mass ²⁾	g	206	
Supply of the logic			
Logic voltage U_{Bus} ³⁾	V DC	5	
Maximum current consumption from U_{Bus}	mA	280	
Relay output			
Connection technology		2-wire technology	
Rated output voltage	V DC	220	
	V AC	230	
Contact version		4 potential-free contacts	
Switching current	A	≤ 8	
Switching capacity	VA	≤ 2 000	
Switching frequency	No load	Hz	20
	With load	Hz	0.1
Typical release time		ms	5
Useful life	Mechanical		10 * 10 ⁶ switching cycles
	Electrical		100 000 switching cycles
Common potentials		All contacts potential-free	

¹⁾ Dimension drawings and dimensions, see page 121

²⁾ Including plug and bus socket module

³⁾ Via bus socket module

Temperature modules

S20-AI-x-xTx



These modules are designed for use within an S20 station. The RTD modules are used to acquire the signals from resistive temperature sensors. The UTH modules are used to acquire the signals from conventional thermocouples in an industrial environment. The two Pt 100 inputs (CJ1 and CJ2) can be used as a sensor input or as an external reference point.

- ▶ **Detection of resistive temperature sensors or thermocouples**
- ▶ **4 to 9 inputs**
- ▶ **Protected against overload and short circuit**
- ▶ **Connection of actuators in 2-wire, 3-wire or 4-wire connection technology**

■ For more information, please visit: www.boschrexroth.com/cat-s20-temp

Technical specifications					
Type		S20-AI-4-RTD	S20-AI-8-RTD	S20-AI-4-UTH	S20-AI-8-UTH
Design ¹⁾		3	2	3	2
Mass ²⁾	g	144	215	144	203
Supply of the logic					
Logic voltage U_{Bus} ³⁾	V DC	5	5	5	5
Maximum current consumption from U_{Bus}	mA	140	180	160	180
Supply of peripherals					
Supply of analog modules U_A	V DC	24	24	24	24
Maximum current consumption from U_A	mA	17	25	40	70
Overvoltage / reverse polarity protection supply voltage		Electronic (35 V, 0.5 s)/polarity protection diode			
Analog inputs					
Number of analog inputs		4 ⁴⁾	8 ⁴⁾	5 ⁵⁾	9 ⁶⁾
Connection technology		2-wire, 3-wire, 4-wire technology (shielded)		2-wire technology (shielded, twisted pair)	
Supported sensor types (TC)		–	–	U, T, L, J, E, K, N, S, R, B, C, W, HK	U, T, L, J, E, K, N, S, R, B, C, W, HK
Supported sensor types (RTD)		Pt, Ni, KTY, Cu sensors		Pt 100 (2 external reference points, can also be used as a sensor input)	Pt 100 (4 external reference points, can also be used as a sensor input)
Linear resistance range	Ω	0 ... 500	0 ... 500	–	–
	k Ω	0 ... 5	0 ... 5	–	–
Measured value display	15 bits + sign	Bit	16	16	16
Input filter time	Configurable	ms	40, 60, 100, 120	40, 60, 100, 120	40, 60, 100, 120
Input resistance: Voltage input –5 V ... +5 V		M Ω	–	–	Typ. 5 (with 24 V peripheral power voltage applied)
Voltage on the TC input		V DC	–	–	Max. 40 (1 min.)

¹⁾ Dimension drawings and dimensions, see page 121

²⁾ Including plug and bus socket module

³⁾ Via bus socket module

⁴⁾ For resistive temperature sensors

⁵⁾ 4 inputs for thermocouples or linear voltage, additional 1 input –5 V ... +5 V

⁶⁾ 8 inputs for thermocouples or linear voltage, additional 1 input –5 V ... +5 V

Communication modules

S20-DALI-2-PWR, S20-RS-UNI, S20-KNX-1

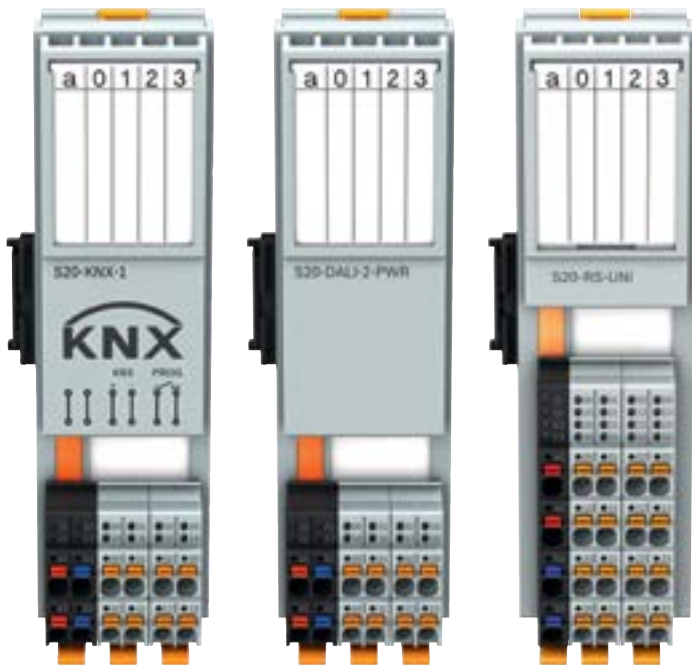

These modules are designed for use within an S20 station. The 2-channel DALI master enables communication with two DALI networks including their bus voltage supply with up to 230 mA each.

The RS-UNI module enables the operation of standard peripheral devices with a serial interface on a bus system. The KNX module is a one-channel interface to the KNX bus.

- ▶ **RS232, RS485/422**
- ▶ **Multi-protocol support**
- ▶ **DALI master including DALI power supply unit**
- ▶ **KNX interface**
- ▶ **Electronic nameplate**

■ For more information, please visit: www.boschrexroth.com/cat-s20-com

Technical specifications				
Type		S20-DALI-2-PWR	S20-RS-UNI	S20-KNX-1
Design ¹⁾		7	3	7
Mass ²⁾	g	137	135	137
Supply of the logic				
Logic voltage U_{Bus} ³⁾	V DC	5	5	5
Maximum current consumption from U_{Bus}	mA	65	200	70
Supply of peripherals				
Supply of digital input modules U_i	V DC	24	–	–
Maximum current consumption from U_i	mA	370	–	–
Overvoltage / reverse polarity protection supply voltage		Electronic (35 V, 0.5 s)/ parallel diode	–	–
DALI interface				
Number		2	–	–
Number of channels		2 (DALI 1, DALI2)	–	–
Note		The data are valid for both DALI bus 1 and DALI bus 2.	–	–
Typical supply voltage (bus voltage)	V DC	16	–	–
Output current ⁴⁾	mA	230	–	–
Output current during short-circuit	mA	≤ 250	–	–
Current carrying capacity (bus load)	mA	≤ 195	–	–
Transmission rate	Bit/s	1 200	–	–
Protective device		Bus protected up to 250 V AC	–	–
RS232, RS485/422 interface				
Transmission speed ⁵⁾	kBit/s	–	0.11 ... 250	–
Supported protocols		–	Transparent, end-to-end, XON/XOFF, Modbus RTU (master support)	–
Input buffer	kByte	–	4	–
Output buffer	kByte	–	1	–
Data bits		–	5 ... 8	–
Stop bits		–	1 or 2	–
KNX interface				
Number		–	–	1
Transfer rate	Bit/s	–	–	9 600
Typical supply voltage	V DC	–	–	30
Communication standard		–	–	EN 50090 (ISO/IEC 14543-3)

¹⁾ Dimension drawings and dimensions, see page 121

²⁾ Including plug and bus socket module

³⁾ Via bus socket module

⁴⁾ Guaranteed

⁵⁾ Parameterizable

Technology modules – incremental value encoder

S20-CNT-INC-2/2, S20-INC-2



These modules are designed for use within an S20 station. They are used for bus-synchronous evaluation of the position of incremental value sensors. The CNT module also serves to acquire fast pulse sequences from sensors.

- ▶ **For reading encoder positions (incremental encoders)**
- ▶ **Digital inputs**
- ▶ **Digital outputs**

■ For more information, please visit: www.boschrexroth.com/cat-s20-tech

Technical specifications			
Type		S20-CNT-INC-2/2	S20-INC-2
Design ¹⁾		2	2
Mass ²⁾	g	205	205
Supply of the logic			
Logic voltage U_{Bus} ³⁾	V DC	5	5
Maximum current consumption from U_{Bus}	mA	120	120
Supply of peripherals			
Supply of digital input modules U_i	V DC	24	24
Typical current consumption from U_i ⁴⁾	mA	50.5	50.5
Overvoltage / reverse polarity protection supply voltage		Electronic (35 V, 0.5 s)/parallel diode	
Counter input			
Number of inputs		2 (S1, S2)	–
Rated input voltage	V DC	24	–
Permissible cable lengths	m	30	–
Incremental value encoder inputs			
Number of inputs		2 (A1, /A1, B1, /B1, Z1, /Z1; A2, /A2, B2, /B2, Z2, /Z2)	2 (A1, /A1, B1, /B1, Z1, /Z1; A2, /A2, B2, /B2, Z2, /Z2)
Encoder signals		Symmetric or asymmetric encoders	
Cable length	m	30	30
Encoder types			
Symmetric incremental encoders			
Number		≤ 2 (A, /A, B, /B, (Z, /Z))	≤ 2 (A, /A, B, /B, (Z, /Z))
Input frequency	kHz	Max. 300 (1 channel wired)	Max. 300
Encoder supply voltage	V DC	5	5
Asymmetric incremental encoders			
Number		≤ 2 (A, B, (Z))	≤ 2 (A, B, (Z))
Input frequency	kHz	Max. 300 (1 channel wired)	Max. 300
Digital inputs			
Number of digital inputs		8 (CNT: G1, G2, Dir1, Dir2, INC: Ref1, Ref2, L1, L2)	10 (IN1 ... IN6, Ref1, Ref2, L1, L2)
Connection technology		1-wire technology (optionally 2-wire, 3-wire technology)	
Input description		EN 61131-2 Type 3	EN 61131-2 Type 3
Rated input voltage	V DC	24	24
Rated input current per channel	mA	2.5	2.5
Digital outputs			
Number of digital outputs		2 (Out1, Out2)	2 (Out1, Out2)
Connection technology		1-wire technology	
Rated output voltage	V DC	24	24
Output current per channel	mA	≤ 500	≤ 500
Short-circuit protection, overload protection of the outputs		Yes	Yes

¹⁾ Dimension drawings and dimensions, see page 121

²⁾ Including plug and bus socket module

³⁾ Via bus socket module

⁴⁾ Internal current consumption; without wiring the terminal points

Technology modules – SSI interface

S20-SSI-AO-1/1, S20-AI6-AO2-SSI2



The axis modules are designed for use within an S20 station. The SSI interfaces are used to acquire the data from absolute encoders. Transmission rates of up to 2 MHz or 4 MHz are supported.

The acquisition of analog input signals and output of analog signals, e.g. for command value setting for hydraulic drives, is partially supported.

- ▶ **1-axis or 2-axes module**
- ▶ **Hydraulic axes**
- ▶ **Synchronous process data processing**
- ▶ **Electronic nameplate**
- ▶ **Reversal of rotation direction**

■ For more information, please visit: www.boschrexroth.com/cat-s20-tech

Technical specifications				
Type		S20-SSI-AO-1/1		S20-AI6-AO2-SSI2
Design ¹⁾		7		2
Mass ²⁾	g	135		205
Supply of the logic				
Logic voltage U_{Bus} ³⁾	V DC	5		5
Maximum current consumption from U_{Bus}	mA	140		300
Supply of peripherals				
Supply of digital input modules U_i	V DC	24		24
SSI interface				
Number		1		2
Encoder signals		Single-turn and multi-turn encoder, length measuring rods		Clock inverted, Data inverted (SSI)
Clock frequency		Up to 2 MHz		Up to 4 MHz
Resolution	Bit	8 ... 56		8 ... 31
Overvoltage protection		Electronic (35 V, permanent)		Electronic, per axis
Short-circuit protection, overload protection				Electronic
Analog outputs				
Number of analog outputs		1		2
Connection technology				2-wire technology (shielded, twisted pair)
D/A conversion time	μ s	5		–
Output value representation	15 bits + sign	Bit	16	16
Overvoltage protection				Electronic (35 V, permanent)
Short-circuit protection, overload protection				Electronic
Transient protection				Suppressor diode
Analog outputs, current				
Current output signal	mA	0 ... 20, 4 ... 20, -20 ... 20		0 ... 20, 4 ... 20, -10 ... 10, -20 ... 20
Precision	From output range end value	%	Typ. 0.1	–
Analog outputs, voltage				
Voltage output signal	V	0 ... 5, -5 ... 5, 0 ... 10, -10 ... 10		0 ... 10, 0.1 ... 10, -10 ... 10
Precision	From output range end value	%	Typ. 0.1	Typ. 0.1

¹⁾ Dimension drawings and dimensions, see page 121

²⁾ Including plug and bus socket module

³⁾ Via bus socket module

Technology module – pulse-width modulation

S20-PWM-2/2, S20-PWM-4T

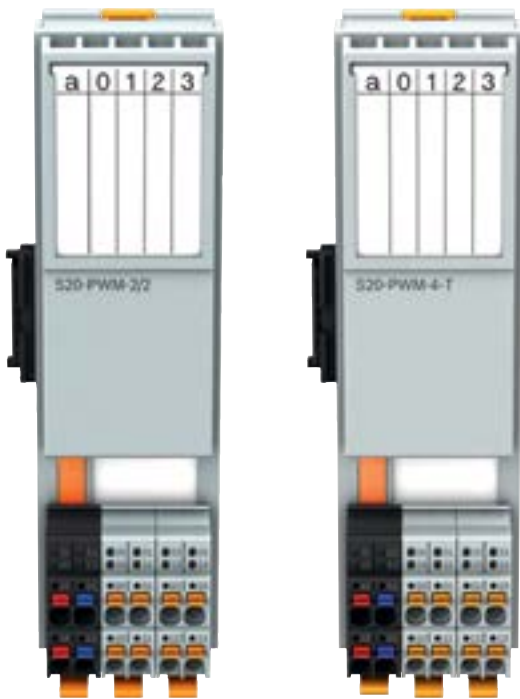

These modules are designed for use within an S20 station. The S20-PWM-2/2 module offers two independent channels for pulse-width modulation of the output signals. The S20-PWM-4-T module is used to control up to four hydraulic proportional and switching valves without displacement encoders using pulse-width modulation.

- ▶ **2 or 4 PWM outputs**
- ▶ **5 or 24 V DC output voltage**
- ▶ **2-wire technology**
- ▶ **Electronic nameplate**
- ▶ **Diagnostic and status display**

■ For more information, please visit: www.boschrexroth.com/cat-s20-tech

Technical specifications			
Type		S20-PWM-2/2	S20-PWM-4-T
Design ¹⁾		7	7
Mass ²⁾	g	130	100
Supply of the logic			
Logic voltage U_{Bus} ³⁾	V DC	5	5
Maximum current consumption from U_{Bus}	mA	150	300
Supply of peripherals			
Supply of digital input modules U_i	V DC	24	24
Overvoltage / reverse polarity protection supply voltage		Electronic (35 V, 0.5 s)	Field effect transistor (FET) in the GND path
Transient protection		–	Suppressor diode
Protection	A	–	Internal safety fuse, 8 A
Reverse polarity protection supply voltage		Parallel diode, with external security 5 A (only for commissioning)	–
PWM outputs			
Number of outputs		2	4
Connection technology		2-wire technology	2-wire technology
Operation mode		PWM, pulse generator, push-pull output	Static PWM, valve control
Rated output voltage U	V DC	24 (U_o -1.1 V), 5	24
Maximum rated current U_o	A	0.5 (at 24 V DC), 0.01 (at 5 V DC)	2.7 (per channel), 6.4 (total)
Frequency range	Hz	0 ... 65 535	50 ... 5 000
Duty cycle	%	0 ... 100	0 ... 100
Short-circuit-proof		Yes	Internal safety fuse
Short-circuit current	A	2.2 (for < 1.2 μ s, auto-retry after 40 μ s, 24 V output)	4

¹⁾ Dimension drawings and dimensions, see page 121

²⁾ Including plug and bus socket module

³⁾ Via bus socket module

Technology module – power measurement

S20-PM-EF



This module is designed for use within an S20 station. The power measurement module is used to directly measure AC currents up to 5 A, including neutral conductor current and phase voltages up to 400 V AC (phase to neutral conductor) or external circuit voltages up to 690 V AC (phase to phase). The module is used to analyze AC networks. It can, for example, be used in distribution systems for measuring current, voltage and power, as well as for the determination of distortions and harmonics.

- ▶ **4 inputs, 0 ... 5 A AC for phase currents and neutral conductor current**
- ▶ **3 inputs for external circuit voltages up to 690 V AC, can be connected directly**
- ▶ **Harmonics analysis**
- ▶ **Determination of maximum values**
- ▶ **Energy counter**

■ For more information, please visit: www.boschrexroth.com/cat-s20-tech

Technical specifications			
Type	S20-PM-EF		
Design ¹⁾	8		
Mass ²⁾	g	245	
Supply of the logic			
Logic voltage U_{Bus} ³⁾	V DC	5	
Maximum current consumption from U_{Bus}	mA	80	
Measurement input current			
Input description	Acquisition of the currents I1 ... I3 and IN, up to 5 A AC can be connected directly		
Number of inputs	4		
Current measurement range	Range exceedance starting at 5 A	A AC	0 ... 6
Rated current I_N		A AC	5
Rated current range		A AC	0 ... 5
Load	Internal	Ω	48
Overload		1.4 times continuous; 150 A for 10 ms	
Precision	From the rated value	%	0.25
Scanning rate		Samples/s	8 000
Process data update		μ s	< 500
Measurement input voltage			
Input description	Acquisition of phase voltages U1 ... U3, for external circuit voltages up to 690 V AC (conductor-conductor) can be connected directly		
Number of inputs	3		
Measurement range voltage		V AC	0 ... 440
Rated voltage range	Conductor-conductor, interlinked	V AC	0 ... 690
	Conductor-neutral conductor, unchained	V AC	0 ... 400
Voltage (N-G)		V	≤ 45
Mains frequency		Hz	40 ... 70
Input filter		kHz	3.3
Overload		1.2 times the rated value	
Precision	From the rated value	%	0.25
Scanning rate		Samples/s	8 000
Process data update		μ s	< 500

¹⁾ Dimension drawings and dimensions, see page 121

²⁾ Including plug and bus socket module

³⁾ Via bus socket module

Boost module logic supply

S20-PWR



This module is designed for use within an S20 station. If the maximum load on the bus coupler for local bus supply (logic supply U_{BUS}) is reached, this module can be used to provide this voltage again. A 24 V DC voltage (U_L) is generated on the module from which U_{BUS} is generated.

- ▶ **Supply of the 24 V voltage U_L for generation of the logic supply U_{BUS}**
- ▶ **Diagnostic and status display**

■ For more information, please visit: www.boschrexroth.com/cat-s20-pwr

Technical specifications		
Type		S20-PWR
Design ¹⁾		9
Mass ²⁾	g	107
Supply of the bus coupler		
Supply of the logic voltage U_L	V DC	24
Maximum permitted voltage range ³⁾	%	-20/+25
Power supply to U_{Bus}	A	≤ 4
Maximum current consumption from U_L ⁴⁾	A	1.2

¹⁾ Dimension drawings and dimensions, see page 121

²⁾ Including plug and bus socket module

³⁾ Including all tolerances, including ripple

⁴⁾ $I_{Bus} = 4 \text{ A}$; $U_L = 19.2 \text{ V}$

Safety related input modules

S20-SSDI-8/4, S20-PSDI-8/4

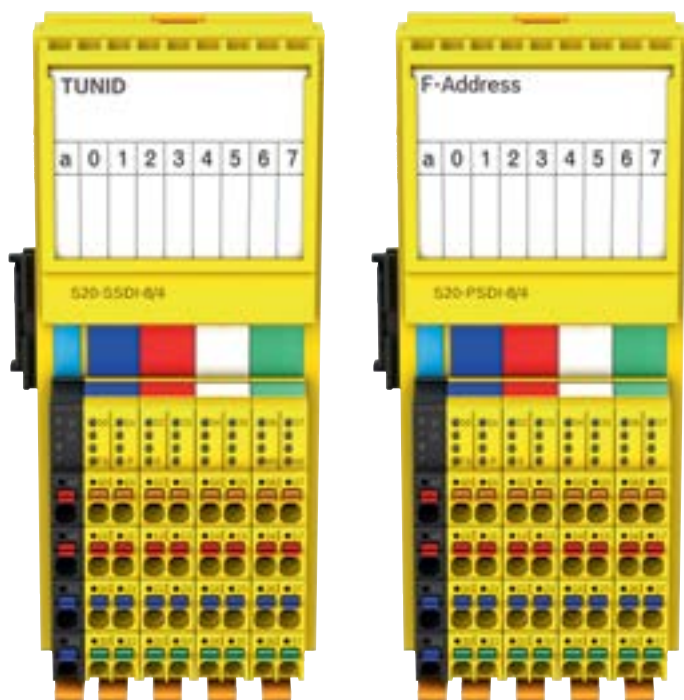

These modules are designed for use within an S20 station. These are safety-related digital input modules for use in CIP Safety on Sercos or PROFIsafe systems. The modules have 4 safe digital inputs with two-channel assignment or 8 safe digital inputs with single-channel assignment.

- ▶ **CIP Safety on Sercos or PROFIsafe**
- ▶ **Safety-related inputs**
- ▶ **SIL 3 as per EN 61508**
- ▶ **SIL CL 3 as per EN 62061**
- ▶ **Category 4/PL e as per EN ISO 13849-1**

■ For more information, please visit: www.boschrexroth.com/cat-s20-safety

Technical specifications			
Type		S20-SSDI-8/4	S20-PSDI-8/4
Design ¹⁾		2	2
Mass ²⁾	g	≈ 220	≈ 220
Operation mode		CIP Safety on Sercos, extended data format with 12 bytes	PROFIsafe process data operation with 4 words
Safety related digital inputs			
Number of digital inputs		4 two-channel or 8 single-channel	
Safety characteristics			
Achievable SIL ³⁾	Single-channel	SIL 2	SIL 2
	Two-channel	SIL 3	SIL 3
Supply voltage U_{Bus} (logic)			
Logic voltage U_{Bus}	V DC	5	5
Maximum current consumption from U_{Bus}	mA	310	310

¹⁾ Dimension drawings and dimensions, see page 121

²⁾ Including plug

³⁾ Depending on the parameterization and wiring

Safety related digital output modules

S20-SSDO-8/3, S20-PSDO-8/3

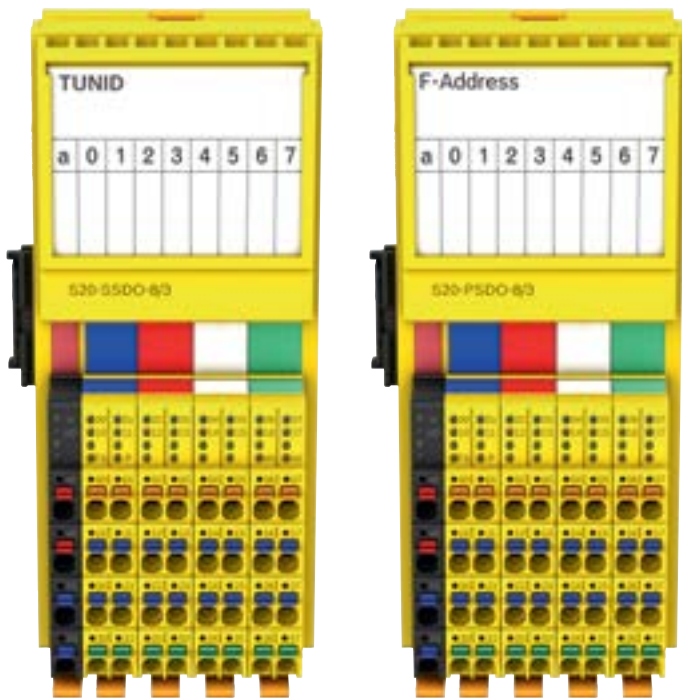

These modules are designed for use within an S20 station. These are safety-related digital output modules for use in CIP Safety on Sercos or PROFIsafe systems. The module has 4 safe digital outputs for two-channel assignment or 8 safe digital outputs for single-channel assignment.

- ▶ **CIP Safety on Sercos or PROFIsafe**
- ▶ **Safety-related outputs**
- ▶ **SIL 3 as per EN 61508**
- ▶ **SIL CL 3 as per EN 62061**
- ▶ **Category 4/PL e as per EN ISO 13849-1**

■ For more information, please visit: www.boschrexroth.com/cat-s20-safety

Technical specifications			
Type		S20-SSDO-8/3	S20-PSDO-8/3
Design ¹⁾		2	2
Mass ²⁾	g	≈ 220	≈ 220
Operation mode		CIP Safety on Sercos, extended data format with 12 bytes	PROFIsafe process data operation with 4 words
Safety related digital outputs			
Number of digital outputs		4/8 (two-channel/single-channel, plus-switching)	
Supply		Supply voltage U _o (actuators)	
Safety characteristics			
As per IEC 61508/EN 61508			
Achievable SIL ³⁾	Single-channel	SIL 2	SIL 2
	Two-channel	SIL 3	SIL 3
Supply voltage U _{Bus} (logic)			
Logic voltage U _{Bus}	V DC	5	5
Maximum current consumption from U _{Bus} ⁴⁾	mA	280	280

¹⁾ Dimension drawings and dimensions, see page 121

²⁾ Including plug

³⁾ Depending on the parameterization and wiring

⁴⁾ All outputs set; supply by U_o of 19.2 V DC ... 30.2 V DC

S67E

The S67E I/O system supports the globally established communication standard IO-Link and thus enables future-proof machine topologies by connecting intelligent sensors and actuators. Thanks to the robust design with IP65/IP67 degree of protection and high EMC interference immunity, the modules are ideal for field installation and allow for maximum flexibility for individual solutions. Even under extreme ambient conditions, they offer a reliable, machine-oriented and completely cabinet-less installation.

Information on other IP67 I/O components (Fieldline) is available at www.boschrexroth.com/automation.

- ▶ **Degree of protection IP65/67**
- ▶ **IO-Link master according to specification V1.1**
- ▶ **Open standard according to IEC 61131-9 for integration of third party devices**
- ▶ **Standard extended temperature range from -25 ... +60 °C**
- ▶ **Gateways for Sercos and PROFINET**
- ▶ **Preventative maintenance thanks to operating hours counter, wear indicator and diagnostics**
- ▶ **Easy assembly thanks to low wiring costs**



- ▶ **Communication modules**
IO-Link-capable fieldbus devices are integrated into the automation network via the S67E communication modules.



Communication modules

S67E-x-IOL8-DI4-M12-6P



The S67E units are designed for use within a Sercos or PROFINET network. They provide for the operation of up to eight IO-Link sensors/actuators and also the acquisition of digital signals.

- ▶ **8 IO-Link ports – 4x Class A, 4x Class B (with additional voltage supply)**
- ▶ **4 digital inputs**
- ▶ **Connection to Sercos or PROFINET network with M12 connectors (D-coded)**
- ▶ **Transmission rate 100 Mbit/s**
- ▶ **Integrated web server for web-based management**

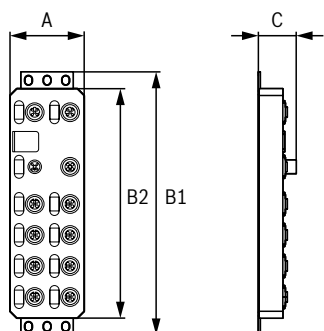

Dimensions			
Type		S67E-S3-IOL8-DI4-M12-6P	S67E-PN-IOL8-DI4-M12-6P
A	mm	60	60
B1	mm	212	212
B2	mm	185	185
C	mm	30.5	30.5
Mass	g	480	480

■ For more information, please visit: www.boschrexroth.com/cat-s67e-io

Technical specifications				
Type		S67E-S3-IOL8-DI4-M12-6P		S67E-PN-IOL8-DI4-M12-6P
Interfaces				
Fieldbus system		Sercos		PROFINET IO device
Number of interfaces		2		2
Connection point designation				Copper cable
Connection type				M12 plug, D-coded
Transmission speed ¹⁾	MBit/s	100		100
Cycle time	µs	250		1 000
Supply				
Connection type				M12 plug, T-coded
Number of poles		4		4
Supply voltage ⁴⁾	V DC	24		24
	%	-25/+30		-25/+30
Maximum current consumption from U _s (Module electronics and sensors)	A	12		12
IO-Link ports				
Connection type				M12 plug
Cycle time (per channel)	ms	< 2		< 2
Overload protection				Electronic
Permissible cable length to sensor	m	< 20		< 20
Class A				
Number of ports		4		4
Connection technology				3-wire technology
PIN4	Peripheral supply voltage	V DC	24	24
	Rated current per IO-Link port	mA	150	150
PIN1/PIN3	Peripheral supply voltage	V DC	24	24
	Rated current per IO-Link port	mA	200	200

¹⁾ With auto-negotiation

²⁾ According to EN 60068-2-6/IEC 60068-2-6

³⁾ According to EN 60068-2-27/IEC 60068-2-27

⁴⁾ Including all tolerances, including ripple

S67E-x-IOL8-DI4-M12-6P

■ For more information, please visit: www.boschrexroth.com/cat-s67e-iol

Technical specifications				
Type			S67E-S3-IOL8-DI4-M12-6P	S67E-PN-IOL8-DI4-M12-6P
Class B				
Number of ports			4	4
Connection technology			5-wire technology	
PIN4	Peripheral supply voltage	V DC	24	24
	Rated current per IO-Link port	mA	150	150
PIN1/PIN3	Peripheral supply voltage	V DC	24	24
	Rated current per IO-Link port	mA	200	200
PIN2/PIN5	Peripheral supply voltage	V DC	24	24
	Rated current per IO-Link port	A	1.6	1.6
	Max rated current per IO-Link port upon activation	A	2	2
Mechanical tests				
Vibration resistance ²⁾	g		5	5
Shock resistance ³⁾	g		30 (11 ms duration, half-sine shock pulse)	
Continuous shock resistance ³⁾	g		10	10
General data				
Color			Anthracite	
Ambient temperature (operation)	°C		-25 ... +60	-25 ... +60
Ambient temperature (storage/transport)	°C		-25 ... +85	-25 ... +85
Permissible humidity (operation)	%		5 ... 95	5 ... 95
Permissible air humidity (storage / transport)	%		5 ... 95	5 ... 95
Air pressure (operation)	Up to 3 000 m above sea level	kPa	70 ... 106	70 ... 106
Air pressure (storage/transport)	Up to 3 000 m above sea level	kPa	70 ... 106	70 ... 106
Degree of protection			IP65/IP67	IP65/IP67
Protection category			III, IEC 61140, EN 61140, VDE 0140-1	III, IEC 61140, EN 61140, VDE 0140-1
Housing material			Pocan®	Pocan®

¹⁾ With auto-negotiation

²⁾ According to EN 60068-2-6/IEC 60068-2-6

³⁾ According to EN 60068-2-27/IEC 60068-2-27

⁴⁾ Including all tolerances, including ripple



Safety controls

Safety on Board is the comprehensive safety concept with scaled solutions, from drive-integrated safety technology to compact safety controls and multi-protocol capable safety controls for extended systems and complex machines.

With Safety on Board from Bosch Rexroth, you can reduce the level of complexity of creating standards-compliant safety systems. We support you through the risk assessment and the development of the safety concepts, through the selection of suitable components right through to implementation in the machine and the training of your employees.



SafeLogic 166

Safety functions	168
Software – SafetyManager	170
Safety components	171

SafeLogic compact 172

Software tool – SafeLogic Designer	174
CPU modules – SLC-3-CPUx	176
Gateway modules – SLC-x-Gxxx	178
Digital I/O modules – SLC-3-xTxx	180
Relay modules – SLC-A-UExxx	182
Function module – SLC-3-MOC000300	184

SafeMotion

For information on drive-based safety technology, refer to chapter Drive Technology from page 280.

SafeLogic

SafeLogic is a powerful, freely programmable safety control for machines and interlinked, widely extended systems with a large number of safety peripherals.

SafeLogic extends the standard control systems from Bosch Rexroth with safe logic processing for applications up to Cat 4 PL e as per ISO 13849 or SIL 3 as per IEC 62061. The engineering of the standard and safety programs is carried out in an integrated manner with the IndraWorks Engineering framework. By connecting a safety extension module or installing a safety plug-in card, embedded controls and industrial PC can be extended to the safety control. The safety PLC is thus easily integrated in the automation control. Machines and systems can thus be automated holistically – including functional safety – without additional components for safe logic processing.

- ▶ **Cost-effective solution for machines with a broad scope of functions or systems with widely distributed safety peripherals**
- ▶ **Consistent and non-reactive engineering of standard and safety applications with IndraWorks Engineering**
- ▶ **Multi-master support (CIP Safety on Sercos and PROFISAFE)**
- ▶ **Integrated complete solution with IndraDrive and SafeMotion**



▶ SafetyManager

IndraWorks Engineering is the universal engineering framework of Bosch Rexroth. With the SafetyManager function toolkit, integrated with the standard components in IndraWorks Engineering, the safety control can be quickly and efficiently commissioned. The SafetyManager Lite variant enables simple diagnostics by means of read access for checking and remote maintenance.



► Safety components

With extension modules, standard controls and industrial PC can be easily upgraded to encompass safety controls. Special I/O modules are used to output safety-related signals.

Safety functions



SafeLogic is the powerful and freely programmable safety control for certified solutions in accordance with IEC 61508 to SIL3, EN 62061 to SILCL3 and EN ISO 13849-1 to Cat. 4 and PL e. It is particularly suitable for complex machines and extensive systems with decently distributed peripherals. In terms of hardware, SafeLogic upgrades the embedded controls XM and industrial PC VPB with safety extension modules and/or safety plug-in cards. This enables the non-safe and safe application to be centrally processed using only one control system. Standard and safety periphery such as input/output modules and drives are uniformly linked to the control system via the identical communication interfaces. Safety programming is carried out uniformly with IndraWorks Engineering and according to the PLCopen Safety standard. In combination with the Sercos automation bus, the CIP Safety on Sercos safety protocol and the IndraDrive drive series with SafeMotion, simple interplay takes place as certified overall motion control solutions.

- ▶ **Cost-effective solution for machines with a broad scope of functions or systems with widely distributed safety peripherals**
- ▶ **Uniform and non-reactive engineering of standard and safety applications with IndraWorks Engineering**
- ▶ **Multi-master support (CIP Safety on Sercos and PROFIsafe)**
- ▶ **Integrated complete solution with IndraDrive and SafeMotion**

■ For more information, please visit: www.boschrexroth.com/cat-sl

Technical specifications	
Type	SafeLogic
Safety-related parameters	
Safety integrity level as per IEC 61508	SIL 3
Safety integrity level as per EN 62061	SILCL3
Category as per EN ISO 13849-1	Category 4
Performance level as per EN ISO 13849-1	PL e
Functions	
Supported control hardware	ILC as of version 14VRS with CML45, CML75, XM21, XM22, XM42, VPB
	MLC as of version 14VRS with CML45, CML75, XM21, XM22, XM42, VPB
	MTX as of version 14VRS with CML45, CML75, CML85, XM42
Total number of safe field devices	99
Number of safe drives	64
Supported safety fieldbuses	Sercos (CSoS), PROFIsafe
Programming	IndraWorks Engineering with SafetyManager function toolkit
Programming language	Function block diagram programming in accordance with IEC 61131-3
Language scope	Basic/extended mode as per PLCopen Safety
Data types	Standard, safety
Library functions Standard	●
Library functions PLCopen	●
Data exchange between Standard and Safety	●

- Standard

Software SafetyManager



The safety application of the certified SafeLogic safety control is created simply and safely with the SafetyManager. Programming is carried out according to the principles of the PLCopen Safety specification. The programming is designed in analogy to the wiring of discrete safety switchgears. The switchgear is replaced by certified function modules and the discrete wiring is replaced by the graphic connections (programming) of the function blocks.

The SafetyManager contains everything for:

- ▶ Project planning
- ▶ Parameterization
- ▶ Programming the safety project
- ▶ Use of function module libraries (e.g. to control SafeMotion or for press applications)

Fully integrated into the standard engineering tool:

- ▶ Same look-and-feel
- ▶ Integrated diagnostics concept
- ▶ Access to all safety I/Os also from the standard control system

Safety integrity systematically integrated in the tool:

- ▶ User manager
- ▶ PLCopen Safety conformity
- ▶ Certified libraries

Application-specific licensing variants:





- ▶ Full version of SafetyManager for application development
- ▶ Read-only SafetyManager Lite for service and remote access

Parameters		
Type		SafetyManager
Programming	IndraWorks Engineering with SafetyManager function toolkit	●
Programming language	Function block diagram programming as per IEC 61131-3	●
Language scope	Basic/extended mode as per PLCopen Safety	●
Data types	Standard, Safety	●
Library functions Standard	E.g. SF_RS, SF_SR, SF_CTD, SF_CTU, SF_TOF, SF_TON	●
Library functions PLCopen	E.g. SF_EmergencyStop, SF_EnableSwitch, SF_GuardLocking, SF_GuardMonitoring	●
Data exchange between standard and safety application		●

Safety components

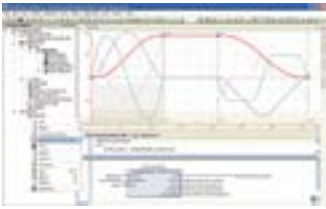
■ For more information, please visit: www.boschrexroth.com/cat-sl

Safety products

	Engineering Framework	IndraWorks Engineering	Page 374
	Extension module for XM embedded control	XFE01.1-SY-01	Page 104
	Extension module for VPB40.4 industrial PC	PFC01.1-SY-01	www.boschrexroth.de/cat-vpb
	Secure digital inputs	S20-SSDI-8/4 S20-PSDI-8/4	Page 154
	Secure digital outputs	S20-SSDO-8/3 S20-PSDO-8/3	Page 156

SafeLogic compact

The programmable SafeLogic compact safety control is the ideal solution for safe logic processing in small to mid-range machines. It is certified according to IEC 61508 (up to SIL3), EN 62061 (up to SILCL3) and EN ISO 13849-1 (up to Cat. 4 and PL e). The modular system design enables optimal adaptation to a variety of different applications. Communication gateways integrate the compact safety control into a variety of automation networks. In combination with the safe Sercos automation bus, the CIP Safety on Sercos safety protocol, and the IndraDrive portfolio of drives incorporating SafeMotion, the simple interplay takes place in the form of certified, complete motion logic solutions.

- ▶ **Compact safety control in modular design**
- ▶ **Safety peripherals can be upgraded to include as many as 96 inputs and 48 outputs**
- ▶ **Graphic programming with comprehensive module library**
- ▶ **Direct integration of the IndraDrive portfolio of drives featuring SafeMotion via Sercos**



- ▶ **SafeLogic Designer**
Engineering tool for easy and intuitive configuration and programming of the SafeLogic compact safety control.



- ▶ **CPU modules SLC-3-CPUx**
Central process units of the compact safety control. They process all safety-related input signals.

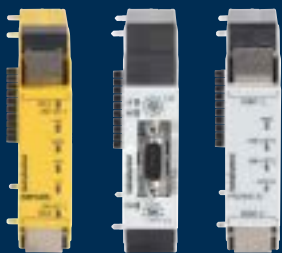
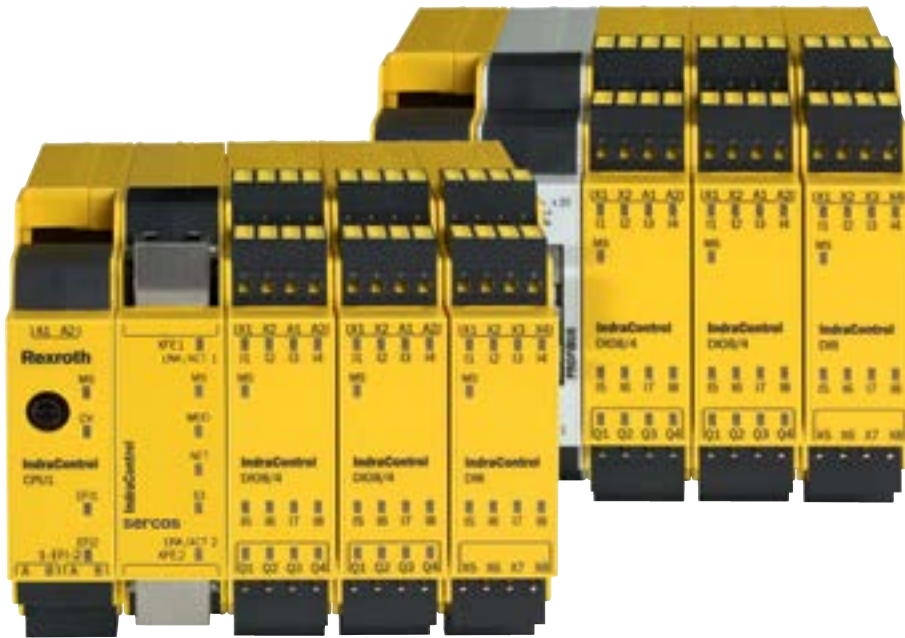

▶ **Gateway modules
SLC-x-Gxxx**
Communication interfaces for integration into the automation network.



▶ **Function module
SLC-3-MOC00030**
Allows for direct connection of different encoder types and offers a variety of safety functions for drive monitoring.

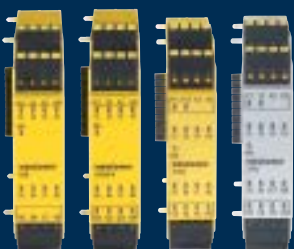

▶ **Digital I/O modules
SLC-3-xTxx**
Are used for connecting common sensors. The diagnosis is effected via standard outputs.

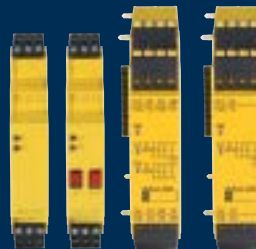

▶ **Relay modules
SLC-A-UExxx**
Provide two-channel, contact-based outputs with positively driven relay contacts.

Software tool

SafeLogic Designer



The SafeLogic Designer software tool is used for simple and clear configuration and programming of the SafeLogic compact safety control. Commissioning is quick, involving just three steps: control configuration, logic programming, and download and verification. The intuitive user guidance, clear module and element information, graphic function chart programming with extensive module library, offline simulation and reporting function simplify the engineering of safety-related applications. The SafeLogic Designer can be used both on a stand-alone basis and as a device type manager (DTM) in conjunction with the engineering framework, IndraWorks Engineering.

- ▶ **Intuitive engineering of individual or EFI-connected stations**
- ▶ **Detailed logic and hardware mapping**
- ▶ **Graphic programming of function block diagrams of up to 255 logic blocks**
- ▶ **Comprehensive module library**
- ▶ **Offline simulation**

■ For more information, please visit: www.boschrexroth.com/cat-slc

Technical specifications		
Type	SafeLogic Designer	
Software functions		
Hardware configurator		●
System diagnostics		●
Programming		Function plan
Library functions		Logic, start/edge, deceleration, counter/clock, EDM, muting, press lines, light curtains, switches, two-hand operation, and others
Logic editor, including tag name editor		●
Documentation of the function blocks		●
Matrix representation of inputs/outputs		●
Offline logic simulation		●
Forcing of inputs		●
Run-down detection		●
Logic import and export		●
Fast shut-off with bypass		●
EFI link		In conjunction with CPU1/3
Download and verification		●
System requirements		
Processor		Standard PC
Frequency	GHz	≥ 1
Memory RAM	GB	1
Operating system		Windows XP (32 bit/64 bit), Windows Vista (32 bit/64 bit), Windows 7, Windows 10, Microsoft .Net Framework 3.5
Required storage space	MB	300
General data		
Supported languages		Chinese, German, English, French, Japanese, Spanish, Czech, Turkish
Installation		Stand-alone or as device type manager (in conjunction with IndraWorks Engineering)

- Standard
- Option

CPU modules

SLC-3-CPUx



The CPU modules are the central processing unit of the SafeLogic compact safety control. All the safety-related input signals to/from the activated I/O modules are processed in these modules. They monitor and process the configuration stored in the plug-in memory and the safety program. Data exchange takes place within the system via the FLEXBUS+ communication bus.

- ▶ **Fast commissioning due to system connector**
- ▶ **RS232 connection (USB) for local diagnostics**
- ▶ **Secure device communication via EFI**
- ▶ **Automatic Configuration Recovery (ACR)**

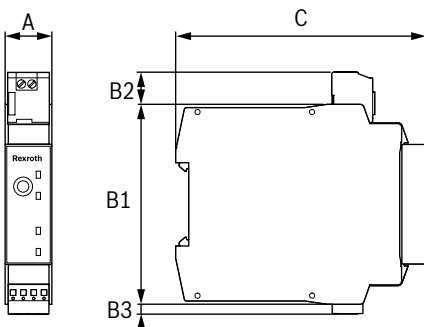

Dimensions				
Type		SLC-3-CPU0	SLC-3-CPU1	SLC-3-CPU3
A	mm	22.5	22.5	22.5
B1	mm	96.5	96.5	96.5
B2	mm	15.4	15.4	15.4
B3	mm	–	5.1	5.1
C	mm	120.6	120.6	120.6
Z (mating area)	mm	33.1	33.1	33.1
Mass (±5 %)	g	111	119	133

■ For more information, please visit: www.boschrexroth.com/cat-slc

Technical specifications				
Type		SLC-3-CPU0	SLC-3-CPU1	SLC-3-CPU3
Safety-related parameters				
Safety integrity level as per IEC 61508		SIL 3	SIL 3	SIL 3
Safety integrity level as per EN 62061		SILCL3	SILCL3	SILCL3
Category as per EN ISO 13849-1		Category 4	Category 4	Category 4
Performance level as per EN ISO 13849-1		PL e	PL e	PL e
PFHd as per EN ISO 13849		$1.07 \cdot 10^{-9}$	$1.69 \cdot 10^{-9}$	$1.69 \cdot 10^{-9}$
T _M (service life) as per EN ISO 13849	a	20	20	20
Electrical data				
Protection category		III, DIN EN 61140	III, DIN EN 61140	III, DIN EN 61140
Type of voltage supply		PELV or SELV	PELV or SELV	PELV or SELV
Supply voltage	V DC	24	24	24
	%	-30/+25	-30/+25	-30/+25
Internal power consumption	W	≤ 2.5	≤ 2.5	≤ 2.5
Overvoltage category		II, as per EN 61131-2	II, as per EN 61131-2	II, as per EN 61131-2
Switch-on time	s	≤ 18	≤ 18	≤ 18
Functions				
Restart inhibit			No	
Contacting monitoring (EDM)			Yes	
Man-material differentiation (muting)			Yes	
Secure device communication via EFI		No		Yes
Flexi-Line			No	Yes
Automatic Configuration Recovery (ACR)			No	Yes
Interfaces				
System connection			System connector SLC-3-MPL000301	
Number of EFI interfaces		-	2	2
Configuration and diagnostics interface		RS232	RS232	RS232, USB
Mechanical tests				
Vibration resistance			1 g, 5 ... 150 Hz, as per EN 60068-2-6	
			3 g RMS, 10 ... 500 Hz, as per EN 60068-2-64	
Shock resistance			30 g, 11 ms, as per EN 60068-2-27	
Continuous shock resistance			10 g, 16 ms, as per EN 60068-2-27	
General data				
Ambient temperature (operation)	°C	-25 ... +55	-25 ... +55	-25 ... +55
Ambient temperature (storage)	°C	-25 ... +70	-25 ... +70	-25 ... +70
Permissible humidity (operation)	%	10 ... 95, no condensation		
Climatic conditions		+55 °C ambient temperature, 95 % relative humidity, as per EN 61131-2		
Electromagnetic compatibility (EMC)		Class A, as per EN 61000-6-2, EN 55011		
Degree of protection – terminals		IP20, EN 60529	IP20, EN 60529	IP20, EN 60529
Degree of protection – enclosure		IP40, EN 60529	IP40, EN 60529	IP40, EN 60529

Gateway modules

SLC-X-GXXX



The gateway modules extend the SafeLogic compact safety control with a communication interface (Sercos, PROFINET, PROFIBUS) for integration into the higher-level automation network. All modules are used for non-safety-related data transmission for control and diagnostic purposes to the master controls. The Sercos gateway also enables the safety-related connection of the IndraDrive drive series with SafeMotion.

- ▶ **Sercos, PROFINET, PROFIBUS interface**
- ▶ **Error and status information for all SafeLogic compact modules**
- ▶ **Freely configurable data sets**
- ▶ **Configuration and diagnosis via TCP/IP communication (Sercos, PROFINET) or PROFIBUS standard DP-V0**

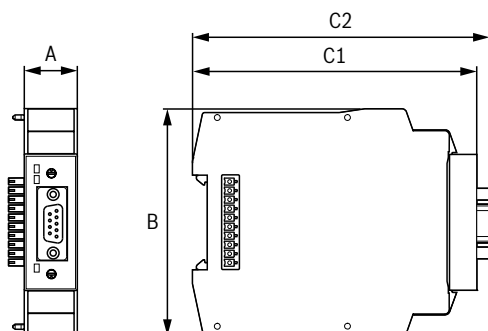

Dimensions				
Type		SLC-3-GS3S	SLC-0-GPNT	SLC-0-GPRO
A	mm	22.5	22.5	22.5
B	mm	96.5	96.5	96.5
C1	mm	120.6	120.6	120.6
C2	mm	–	–	126
Mass (±5 %)	g	130	125	150

■ For more information, please visit: www.boschrexroth.com/cat-slc

Technical specifications				
Type		SLC-3-GS3S	SLC-0-GPNT	SLC-0-GPRO
Safety-related parameters				
Safety integrity level as per IEC 61508		SIL 3	–	–
Safety integrity level as per EN 62061		SILCL3	–	–
Category as per EN ISO 13849-1		Category 4	–	–
Performance level as per EN ISO 13849-1		PL e	–	–
PFHd as per EN ISO 13849		$0.4 \cdot 10^{-9}$	–	–
T _M (service life) as per EN ISO 13849	a	20	–	–
Electrical data				
Protection category		III, DIN EN 61140	III, DIN EN 61140	III, DIN EN 61140
Type of voltage supply		Via FLEXBUS+		
Internal power consumption	W	≤ 2.7	≤ 2.4	≤ 1.6
Interfaces				
Fieldbus		Sercos	PROFINET	PROFIBUS
Connection type system connector		2 x RJ45	2 x RJ45	D-Sub, 9-pin
Baud rate	MBaud	–	–	≤ 12
Data transmission rate		100 MBit/s (100 Base-Tx)	10 MBit/s (10 Base-T)	≤ 12 000 kBit/s
		–	100 MBit/s (100 Base-Tx)	–
Integrated Ethernet switch		–	3-port layer-2-managed switch	–
Mechanical tests				
Vibration resistance		3 g RMS, 10 ... 500 Hz, as per EN 60068-2-64	5 g, 10 ... 500 Hz, as per EN 60068-2-6	
Shock resistance		30 g, 11 ms, as per EN 60068-2-27		
Continuous shock resistance		10 g, 16 ms, as per EN 60068-2-27		
General data				
Ambient temperature (operation)	°C	–25 ... +55	–25 ... +55	–25 ... +55
Ambient temperature (storage)	°C	–40 ... +70	–25 ... +70	–25 ... +70
Permissible humidity (operation)	%	10 ... 95, no condensation		
Climatic conditions		+55 °C ambient temperature, 95 % relative humidity, as per EN 61131-2		
Electromagnetic compatibility (EMC)		Class A, as per EN 61000-6-2, EN 55011		
Degree of protection – terminals		IP20, EN 60529	IP20, EN 60529	IP20, EN 60529
Degree of protection – enclosure		IP40, EN 60529	IP40, EN 60529	IP40, EN 60529

Digital I/O modules

SLC-3-xTxx

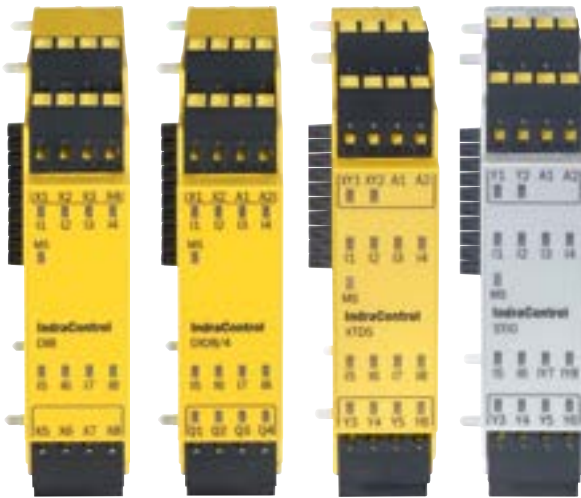

The digital input/output modules are used as a signal connection for the safety peripherals. The connection of all standard sensors provides maximum flexibility. The integrated fast shut-off function reduces the reaction times of the machines and systems and increases their availability. Simple diagnostics are made possible by means of standard outputs with no additional gateway.

- ▶ **Standard and safe inputs/outputs**
- ▶ **Test pulse inputs**
- ▶ **Fast safety response thanks to integrated fast shut-off function**
- ▶ **Monitoring of the connected sensor diagnostic LEDs**

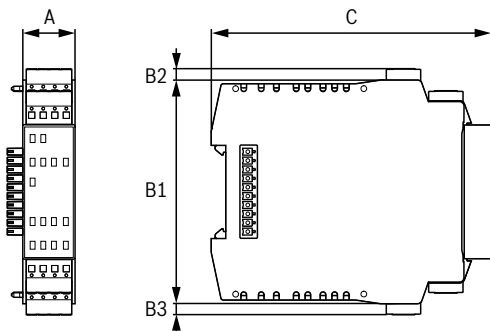

Dimensions		SLC-3-XTDI80302	SLC-3-XTIO84302	SLC-3-XTDS84302	SLC-3-STIO68302
Type					
A	mm	22.5	22.5	22.5	22.5
B1	mm	96.5	96.5	96.5	96.5
B2	mm	5.1	5.1	5.1	5.1
B3	mm	5.1	5.1	5.1	5.1
C	mm	120.6	120.6	120.6	120.6
Mass (±5 %)	g	139	164	139	139

■ For more information, please visit: www.boschrexroth.com/cat-slc

Technical specifications					
Type		SLC-3-XTDI80302	SLC-3-XTIO84302	SLC-3-XTDS84302	SLC-3-STIO68302
Safety-related parameters					
Safety integrity level as per IEC 61508		SIL 3	SIL 3	SIL 3	–
Safety integrity level as per EN 62061		SILCL3	SILCL3	SILCL3	–
Category as per EN ISO 13849-1		Category 4	Category 4	Category 4	–
Performance level as per EN ISO 13849-1		PL e	PL e	PL e	–
PFHd as per EN ISO 13849		0.4 * 10 ⁻⁹ , two-channel	0.4 * 10 ⁻⁹ , two-channel	0.4 * 10 ⁻⁹ , single-channel	–
		–	0.9 * 10 ⁻⁹ , single-channel	–	–
T _M (service life) as per EN ISO 13849	a	20	20	20	–
Electrical data					
Type		SLC-3-XTDI80302	SLC-3-XTIO84302	SLC-3-XTDS84302	SLC-3-STIO68302
Protection category		III, DIN EN 61140	III, DIN EN 61140	III, DIN EN 61140	III, DIN EN 61140
Type of voltage supply		Via FLEXBUS+			
Internal power consumption	W	≤ 2	≤ 2.2	≤ 1.5	≤ 1.5
Functions					
Functions		Fast shut-off, 8 ms	Fast shut-off, 8 ms	Fast shut-off, 8 ms	–
Interfaces					
Number of standard inputs		–	–	–	6/8
Number of safe inputs		8	8	8	–
Number of standard outputs		–	–	4/6	6/8
Number of safe outputs		–	4	–	–
Number of test pulse outputs		8	–	–	–
Mechanical tests					
Vibration resistance		1 g, 5 ... 150 Hz, as per EN 60068-2-6		5 g, 10 ... 500 Hz, as per EN 60068-2-6	
		3 g RMS, 10 ... 500 Hz, as per EN 60068-2-64			
Shock resistance		30 g, 11 ms, as per EN 60068-2-27			
Continuous shock resistance		10 g, 16 ms, as per EN 60068-2-27			
General data					
Ambient temperature (operation)	°C	–25 ... +55	–25 ... +55	–25 ... +55	–25 ... +55
Ambient temperature (storage)	°C	–25 ... +70	–25 ... +70	–25 ... +70	–25 ... +70
Permissible humidity (operation)	%	10 ... 95, no condensation			
Climatic conditions		+55 °C ambient temperature, 95 % relative humidity, as per EN 61131-2			
Electromagnetic compatibility (EMC)		Class A, as per EN 61000-6-2, EN 55011			
Degree of protection – terminals		IP20, EN 60529	IP20, EN 60529	IP20, EN 60529	IP20, EN 60529
Degree of protection – enclosure		IP40, EN 60529	IP40, EN 60529	IP40, EN 60529	IP40, EN 60529

Relay modules

SLC-A-UExxx

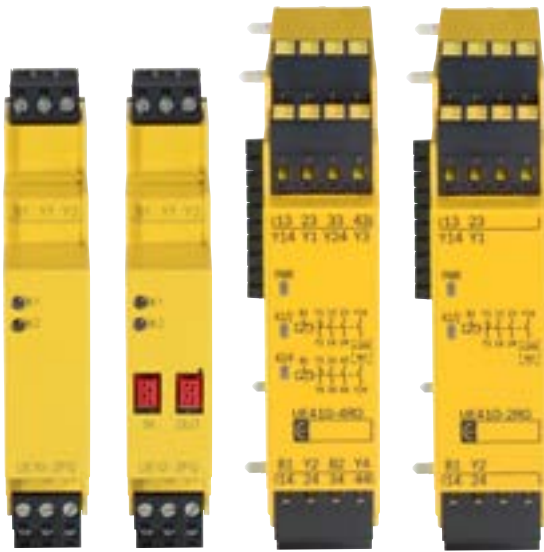

The relay modules upgrade the base station of the SafeLogic compact safety control. They provide two-channel, contact-based outputs with positively driven relay contacts.

- ▶ **Extension of the CPU modules with relay outputs**
- ▶ **Dual-channel outputs with positively driven contacts**
- ▶ **Return signaling path for contactor monitoring (EDM)**
- ▶ **Can be extended to include up to 16 secure relay outputs per station**

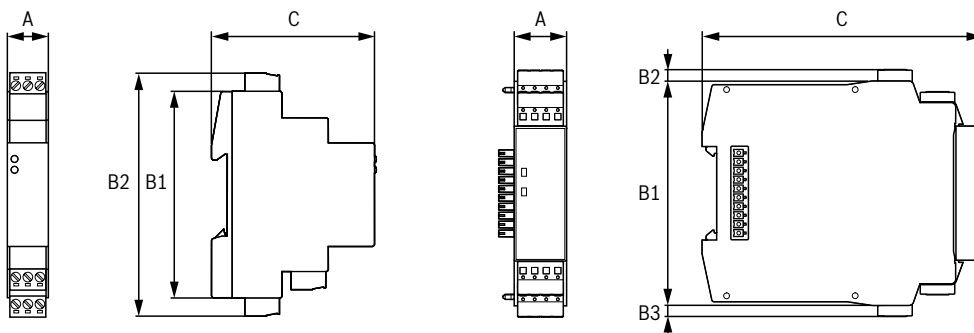

Dimensions		SLC-A-UE10-2FG3D0	SLC-A-UE12-2FG3D0	SLC-A-UE410-2RO4	SLC-A-UE410-4RO4
Type					
A	mm	17.8	17.8	22.5	22.5
B1	mm	89.6	89.6	96.5	96.5
B2	mm	105.5	105.5	5.1	5.1
B3	mm	–	–	5.1	5.1
C	mm	70.8	70.8	120.6	120.6
Mass (±5 %)	g	86	91	160	186

■ For more information, please visit: www.boschrexroth.com/cat-slc

Technical specifications					
Type		SLC-A-UE10-2FG3D0	SLC-A-UE12-2FG3D0	SLC-A-UE410-2RO4	SLC-A-UE410-4RO4
Safety-related parameters					
Safety integrity level as per IEC 61508		SIL 3	SIL 3	SIL 3	SIL 3
Safety integrity level as per EN 62061		SILCL3	SILCL3	SILCL3	SILCL3
Category as per EN ISO 13849-1		Category 4	Category 4	Category 4	Category 4
Performance Level as per EN ISO 13849-1		PL e	PL e	PL e	PL e
PFHd as per EN ISO 13849		$1.05 \cdot 10^{-9}$	$1.58 \cdot 10^{-9}$, two-channel	$1.2 \cdot 10^{-9}$	$1.2 \cdot 10^{-9}$
B _{10d} value		1 * 10 ⁵ switching cycles (AC-15, 230 V, I = 2 A)		–	–
		2.5 * 10 ⁵ switching cycles (AC-15, 230 V, I = 1 A)		–	–
		5.4 * 10 ⁵ switching cycles (DC-13, 24 V, I = 0.5 A)		–	–
		1 * 10 ⁷ switching cycles (DC-13, 24 V, I ≤ 2 A)		–	–
T _M (service life) as per EN ISO 13849	a	20	20	20	20
Electrical data					
Protection category		III, DIN EN 61140	III, DIN EN 61140	III, DIN EN 61140	III, DIN EN 61140
Type of voltage supply		Via FLEXBUS+			
Internal power consumption	W	≤ 3.2	≤ 3.2	1.6	≤ 3.2
Switching current	A	≤ 6	≤ 6	≤ 6	≤ 6
Mechanical useful life (relay contacts)		1 * 10 ⁷ switching cycles			
Electrical useful life (relay contacts)		1 * 10 ⁵ switching cycles			
Interfaces					
Contact type		Positively driven			
Number of safe contact outputs		2	2	2	4
Number of signaling current paths		–	–	1	2
Number of return signaling current paths		1	1	1	2
Number of control inputs		–	–	1	2
Cascadable		No	Yes	No	
Mechanical tests					
Vibration resistance		–	–	5 g, 5 ... 500 Hz, as per EN 60068-2-64	
General data					
Ambient temperature (operation)	°C	0 ... +55	0 ... +55	–25 ... +55	–25 ... +55
Ambient temperature (storage)		–	–	–25 ... +70	–25 ... +70
Permissible humidity (operation)	%	–	–	15 ... 95, no condensation	
Degree of protection – terminals		IP20, EN 60529	IP20, EN 60529	IP20, EN 60529	IP20, EN 60529
Degree of protection – enclosure		IP40, EN 60529	IP40, EN 60529	IP40, EN 60529	IP40, EN 60529

Function module

SLC-3-MOC000300



The function module upgrades the base station of the SafeLogic compact with function-oriented interfaces. Through direct connection to various encoder types, the function module (motion control) provides a wide range of drive monitoring safety functions.

- ▶ **Integrated safety functions SS1, SS2, SOS, SSM, SLS, SDI, SBC**
- ▶ **Freely programmable logic**
- ▶ **For all commonly used encoder interfaces**
- ▶ **Monitoring of max. 10 speed levels, 4 braking ramps and several axes**
- ▶ **Simple connection with encoders**

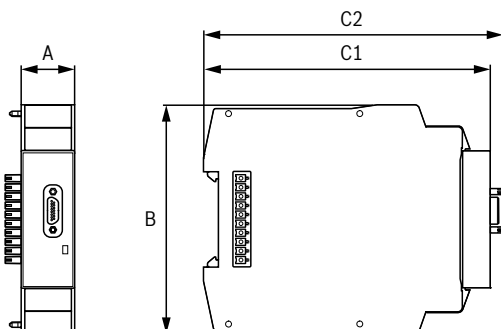

Dimensions		
Type		SLC-3-MOC000300
A	mm	22.5
B	mm	96.5
C1	mm	120.6
C2	mm	126.2
Mass (±5 %)	g	120

■ For more information, please visit: www.boschrexroth.com/cat-slc

Technical specifications		
Type		SLC-3-MOC000300
Safety-related parameters		
Safety integrity level as per IEC 61508		SIL 3
Safety integrity level as per EN 62061		SILCL3
Category as per EN ISO 13849-1		Category 4
Performance level as per EN ISO 13849-1		PL e
PFHd as per EN ISO 13849		$5.0 \cdot 10^{-9}$, two-channel
T _M (service life) as per EN ISO 13849	a	20
Electrical data		
Protection category		III, DIN EN 61140
Type of voltage supply		Via FLEXBUS+
Internal power consumption	W	≤ 2.5
Output voltage for encoder	V	24
Functions		
Functions		Standstill
		Safe stop 1 (SS1)
		Safe stop 2 (SS2)
		Safe operating stop (SOS)
		Safe speed monitoring (SSM)
		Safely limited speed (SLS)
		Safe motion direction (SDI)
		Safe brake control (SBC)
Interfaces		
Encoder interfaces		A/B incremental encoder, HTL
		A/B incremental encoder, RS422
		A/B incremental encoder, TTL
		Sin/cos encoder
		SSI encoder
Data interface		FLEXBUS+
Connection type system connector		Plug, Micro D-Sub, 15-pole
Mechanical tests		
Vibration resistance		1 g, 5 ... 150 Hz, as per EN 60068-2-6
		3 g RMS, 10 ... 500 Hz, as per EN 60068-2-64
Shock resistance		30 g, 11 ms, as per EN 60068-2-27
Continuous shock resistance		10 g, 16 ms, as per EN 60068-2-27
General data		
Ambient temperature (operation)	°C	-25 ... +55
Ambient temperature (storage)	°C	-40 ... +70
Permissible humidity (operation)	%	10 ... 95, no condensation
Climatic conditions		+55 °C ambient temperature, 95 % relative humidity, as per EN 61131-2
Electromagnetic compatibility (EMC)		Class A, as per EN 61000-6-2, EN 55011
Degree of protection – terminals		IP20, EN 60529
Degree of protection – enclosure		IP40, EN 60529

IoT hardware

Operators want to gain insight into manufacturing and be able to evaluate machine data quickly, easily and economically. For this, the hardware used must be intelligent and IoT-capable. This IoT hardware allows operators to react quickly in the event of deviations. This prevents machine failures.

- ▶ **Retrofitting of new and existing systems**
- ▶ **Best connectivity**
- ▶ **Certified hardware**
- ▶ **No programming necessary**



- ▶ **IoT Rack**
The IoT Rack is a pre-configured, wired solution for easy connection of machines to Industry 4.0.



► **IoT sensors**

IoT sensors are used to monitor a wide range of machine data such as acceleration and temperature

IoT Rack



The IoT Rack is a completely pre-configured, wired solution for direct entry into Industry 4.0.

The commissioning effort is very low and no expert knowledge is required.

- ▶ **Complete Industry 4.0 solutions**
- ▶ **Little commissioning effort as no programming required**
- ▶ **Plug-and-run thanks to intelligent configuration**
- ▶ **Refitting of new or existing machines and systems is easily possible**
- ▶ **Powerful and customized hardware**
- ▶ **Degree of protection IP65**

Dimensions

Type		IoT Rack	IoT Rack IoT Gateway	IoT Rack IoT Gateway + I/O	IoT Rack EdgeComputing	IoT Rack HighSampling	IoT Rack HighSampling plus
Width	mm	439	439	439	439	839	839
Height	mm	337	337	337	337	437	437
Depth	mm	150	150	150	150	300	300

■ For more information, please visit: www.boschrexroth.com/cat-ae

Technical specifications							
Type		IoT Rack	IoT Rack IoT Gateway	IoT Rack IoT Gateway + I/O	IoT Rack EdgeComputing	IoT Rack HighSampling	IoT Rack HighSampling plus
Control cabinet connections							
Ethernet port	3 x RJ45 connections	●	●	●	●	●	●
Cable gland	32 sensor cables, 3 ... 6 mm	●	●	●	●	●	●
USB port	1 x USB	●	●	●	●	●	●
HDMI port	1 x HDMI	●	●	●	●	●	●
Power connection	1.5 m cable (Schuko)	●	●	●	●	●	●
Components							
Industrial PC	PR21	–	●	●	–	●	●
	PR43	–	–	–	●	–	–
Embedded control	XM21	–	–	–	–	●	●
S20 bus coupler	S20-ETH-BK	–	–	●	–	●	●
S20 input modules	S20-DI-16/4	–	–	●	–	●	●
	S20-AI-4-I	–	○	○	–	● (6)	● (14)
	S20-RS-UNI	–	○	○	–	●	●
Software							
System software	IoT Gateway	–	●	●	–	●	●
	IoT Insights	–	○	○	●	–	–
	ILC IoT-enabled PLC system	–	–	–	–	●	●
Operating system	Linux Ubuntu Core	–	●	●	–	●	●
	Windows 10 IoT	–	–	–	●	–	–
General information							
Degree of protection	IP65	●	●	●	●	●	●
Power supply	24 V, 6.3 A, 150 W	●	●	●	●	●	●
Certifications	CE	●	●	●	●	●	●
	UL	▼	▼	▼	▼	▼	▼

● Standard ○ Option ▼ In preparation

IoT sensors



Sensors are used to acquire different machine data such as temperature, acceleration, vibration and other environmental influences. Thanks to the robust enclosure and the small design, Rexroth sensors are ideal for industrial use.

- ▶ **Suitable for status monitoring in a variety of machine applications**
- ▶ **Compact and robust enclosure for rough industrial environments**
- ▶ **Refitting of new or existing machines and systems is easily possible**
- ▶ **Immediately ready for use: no programming required**

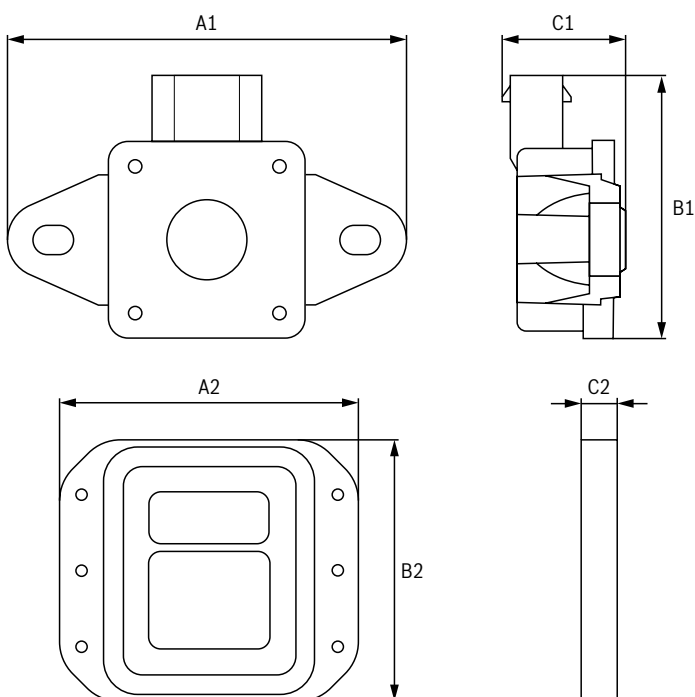

Dimensions			
Type		CISS	SCD
A1	mm	80	-
B1	mm	53.2	-
C1	mm	23.3	-
A2	mm	-	70.9
B2	mm	-	62
C2	mm	-	9.1

■ For more information, please visit: www.boschrexroth.com/cat-ae

Technical specifications		
Type	CISS	SCD
Sensors		
Acceleration	●	●
Temperature	●	●
Digital light	●	●
Magnetometer	●	●
Humidity	●	-
Gyroscope	●	-
Pressure	●	-
Microphone	●	-
Scope of delivery		
Sensor	●	●
USB cable (2 m)	●	-
Fastening element (2 screws, 2 washers and 2 magnet plates)	●	-
Instructions	●	-
Additional features		
Mobile app	○	●
Firmware update	○	-
Windows driver	○	-
Example "Python Scripts"	○	-
Interfaces		
BLE (Bluetooth Low Energy)	○	●
USB	●	-

● Standard ○ Option

DRIVE COMPONENTS

The background is a solid light blue color. In the lower-left quadrant, there are several curved, overlapping bands of a darker blue shade, creating a sense of motion or depth. A thin, dark blue line also curves across the lower-left area, following the general direction of the bands.

4

Portfolio 194

- ▶ Drive components 194

Frequency converters 196

Servo drives 206

- ▶ IndraDrive
Combination options 208
- ▶ IndraDrive Mi
Cabinett-free drive technology 210
- ▶ IndraDrive
Cabinet-based drive technology 230
- ▶ IndraDrive software 272
- ▶ IndraDrive safety technology 280

Motors and gearboxes 286

- ▶ Servo motors and planetary gearboxes 288
- ▶ Kit motors 336

Portfolio

Drive components

Control units



CSB02
BASIC single-axis
Configurable



CDB02
BASIC double-axis
Configurable

Frequency converters



EFC
Converters
0.4 ... 160 kW

Compact servo drives



HCS01
Compact converters
0.1 ... 11 kW



HCS02
Single-axis converters
1.5 ... 11 kW



HCS03
Single-axis converters
11 ... 110 kW



HCT/HCQ
Multi-axis converters
25 kW

Modular servo drives



HMS01/02
Single-axis inverter
5.5 ... 132 kW



HMD01
Double-axis inverter
3 ... 7.5 kW

Synchronous servo motors



MS2N
Intelligent, powerful
 M_{max} 3 ... 360 Nm



MS2E
Ex protection ATEX
 M_{max} 3 ... 119.5 Nm



MKE
Ex protection ATEX, UL/CSA
 M_{max} 4 ... 187 Nm



MSM
Ultra-compact
 M_{max} 0.5 ... 7.1 Nm







Asynchronous servo motors



MAD
Forced ventilated
 P_N 1.8 ... 93.1 kW



MAF
Water-cooled
 P_N 2.6 ... 120 kW

Drive software	
 <p>CSH02 ADVANCED single-axis Configurable</p>	<div style="display: flex; justify-content: space-around; align-items: center;"> <div style="text-align: center;">  <p>MPx</p> <p>Drive software</p> </div> <div style="text-align: center;">  <p>MLD</p> <p>Motion control</p> </div> <div style="text-align: center;">  <p>Technology functions</p> </div> <div style="text-align: center;">  <p>Open Core Engineering</p> </div> <div style="text-align: center;">  <p>Safety functions</p> </div> </div>

Cabinet-free servo drives						
 <p>HMV01/02 Supply unit 15 ... 120 kW</p>	 <p>HMU05 Universal inverters 132 kW ... 4 MW</p>	 <p>KSM Integrated in the motor M_{max} 9 ... 29 Nm</p>	 <p>KMS Near the motor 2.2 ... 11 kW</p>	 <p>KCU Control electronics</p>	 <p>KMV Supply, mains and capacity modules 1.5 ... 7.5 kW</p>	 <p>KNK/KLC</p>

Planetary gearboxes	Linear kit motors			Rotary kit motors		
 <p>GTE/GTM Standard / precision $M_{out max}$ 8 ... 6 000 Nm</p>	 <p>MCL Ironless, self-cooled F_{max} 24 ... 3 320 N</p>	 <p>ML3 With iron, self-cooled F_{max} 120 ... 4 500 N</p>	 <p>MLF With iron, water-cooled F_{max} 800 ... 21 500 N</p>	 <p>MBT Torque motor, synchronous M_{max} 15 ... 13 800 Nm</p>	 <p>MBS High-speed motor, sync. M_{max} 30 ... 4 500 Nm</p>	 <p>1MB High-speed motor, asynchronous P_N 3.5 ... 55 kW</p>

Frequency converters

With EFC3610 and EFC5610, Bosch Rexroth offers you two particularly economical and efficient frequency converter series for the realization of your application – from engineering to daily operation. Both series convince with intelligent features such as expansion options through different I/O and fieldbus modules, user panel with parameter copy function or standardized communication interfaces. They cover a power range from 0.4 kW to 160 kW. This allows you to quickly respond to the urgent requirements of innovative markets and to handle energy responsibly.

- ▶ **Shortest engineering times**
- ▶ **Simple installation with minimized wiring costs**
- ▶ **Flexible communication thanks to multi-protocol interfaces**
- ▶ **Certified safety technology Safe Torque Off**
- ▶ **Application-specific firmware functions**



▶ **Frequency converters EFC3610**

V/f control, easy installation and commissioning as well as an increased power range enable a wide range of applications.



► **Frequency converters**
EFC5610

In addition to the V/f control, the EFC5610 offers the control types SVC and FOC. Easy installation and fast commissioning as well as a large power range enable a broad area of application.

Frequency converters

EFC3610



EFC3610 are universal and low-cost frequency converters for reliable speed control and demand-oriented energy supply. V/f control, easy installation and commissioning as well as an increased power range enable a wide range of applications.

- ▶ **Power range: 0.4 ... 22 kW**
- ▶ **Built-in brake chopper and net filter**
- ▶ **Control technology: V/f**
- ▶ **Operation of asynchronous motors**
- ▶ **Expansion option thanks to I/O and fieldbus modules**
- ▶ **Use in HD mode (heavy duty) and ND mode (normal duty)**
- ▶ **Integrated operator panel for quick and easy commissioning**
- ▶ **Degree of protection: IP20**

Type code	
EFC3610-0K40-1P2-M D A-7P-NNNN-NNNN	
<p>Motor control</p> <p>EFC3610 = V/f control</p> <p>Continuous power</p> <p>E.g. 0K40 = 0.4 kW</p> <p>Power supply</p> <p>1P2 = 1 x AC 200 ... 240 V</p> <p>3P4 = 3 x AC 380 ... 480 V</p> <p>Fieldbus interface</p> <p>M = Modbus RTU</p>	<p>Version</p> <p>NN = Without</p> <p>Display</p> <p>NN = Without (dust cover)</p> <p>7P = 7-segment LED display</p> <p>Degree of protection</p> <p>A = IP20</p> <p>EMC protection category</p> <p>D = Class C3 – industrial environment</p>

Available options and technical specifications: see product documentation (project planning instructions in the media directory: www.boschrexroth.com/mediadirectory)

■ For more information, please visit: www.boschrexroth.com/cat-efc3610

Functions			
Type	EFC3610		
Closed-loop control			V/f
Switching frequency (PWM)	Configurable in 1 kHz steps	kHz	1 ... 15
Start-up torque	At 1.5 Hz (V/f) max.	%	100
	At 3 Hz (V/f) max.	%	150
Frequency resolution	Analog		1/1 000 of the maximum output frequency
	Digital	Hz	0.01
Frequency setting accuracy	Analog	%	±0.1
	Digital	%	±0.01
V/f curve			Freely definable
			Linear
			Square
Ramps	For acceleration and braking		Linear
			S curve
DC brake	Activation frequency	Hz	0 ... 50
	Braking time	s	0 ... 10
Automatic PWM frequency adjustment			Load-dependent adaptation of the PWM frequency
Integrated control			Integrated step-by-step switch
Controller			PID
Bus systems	Internal External		Modbus
			PROFIBUS
			CANopen
			Sercos
			EtherCAT (CANopen profile, CoE)
			Modbus TCP
			PROFINET
			EtherNet/IP
Number of digital inputs	24 V DC (of which 1 x pulse train 50 kHz)		5
Number of digital outputs	24 V DC, 50 mA (pulse train 32 kHz)		1
Number of relay outputs	230 V AC, 30 V DC, 3 A		1
Number of analog inputs	0 ... 10 V or 0 ... 20 mA		2
Number of analog outputs	0 ... 10 V or 0 ... 20 mA		1
Status messages via digital outputs			E.g. operation, command value reached (additional parameters, see technical documentation)
Display	Standard		LED, 5-digit
			Dust protection cover
	Option		Dust cover with 5 diagnostic LEDs
			LCD
Status LED			Rotational direction, operating state

EFC3610

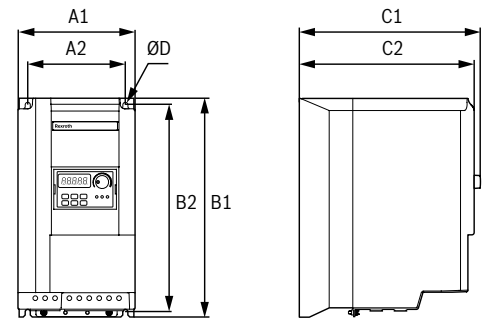

■ For more information, please visit: www.boschrexroth.com/cat-efc3610

Power data 1					Dimensions							
Type	Heavy duty operation		Normal duty operation		A1	A2	B1	B2	C1	C2	ØD	Mass
	Rated power	Continuous rated current	Nominal power	Continuous rated current								
	P_{rated} kW	I_{rated} A	P_{rated} kW	I_{rated} A								m
EFC3610-0K40-1P2	0.40	2.4	–	–	95	66	166	156	167	159	4.5	1.5
EFC3610-0K75-1P2	0.75	4.1	–	–	95	66	166	156	167	159	4.5	1.5
EFC3610-1K50-1P2	1.50	7.3	–	–	95	66	206	196	170	162	4.5	1.9
EFC3610-2K20-1P2	2.20	10.1	–	–	120	80	231	221	175	167	4.5	2.6
EFC3610-0K40-3P4	0.40	1.3	–	–	95	66	166	156	167	159	4.5	1.5
EFC3610-0K75-3P4	0.75	2.3	–	–	95	66	166	156	167	159	4.5	1.5
EFC3610-1K50-3P4	1.50	4.0	–	–	95	66	206	196	170	162	4.5	1.9
EFC3610-2K20-3P4	2.20	5.6	–	–	95	66	206	196	170	162	4.5	1.9
EFC3610-3K00-3P4	3.00	7.4	–	–	120	80	231	221	175	167	4.5	2.6
EFC3610-4K00-3P4	4.00	9.7	–	–	120	80	231	221	175	167	4.5	2.6
EFC3610-5K50-3P4	5.50	12.7	7.5	16.8	130	106	243	228	233	225	6.5	3.9
EFC3610-7K50-3P4	7.50	16.8	11.0	24.3	130	106	243	228	233	225	6.5	4.3
EFC3610-11K0-3P4	11.00	24.3	15.0	32.4	150	125	283	265	233	225	6.5	5.7
EFC3610-15K0-3P4	15.00	32.4	18.5	39.2	150	125	283	265	233	225	6.5	6.4
EFC3610-18K5-3P4	18.00	39.2	22.0	45.0	165	140	315	300	243	233	6.5	8.0
EFC3610-22K0-3P4	22.00	45.0	30.0	60.8	165	140	315	300	241	233	6.5	8.5

Power data 2					
Type			EFC3610-0K40-1P2 ... EFC3610-2K20-1P2	EFC3610-0K40-3P4 ... EFC3610-4K00-3P4	EFC3610-5K50-3P4 ... EFC3610-22K0-3P4
Connection data					
Power supply voltage (U_{mains})	1 x AC	V AC	200 ... 240	–	–
	3 x AC	V AC	–	380 ... 480	380 ... 480
Tolerance of the power supply voltage		%	±10	–15 ... +10	–15 ... +10
Mains frequency (f_{mains})		Hz	50 ... 60	50 ... 60	50 ... 60
Tolerance of the mains frequency		%	±5	±5	±5
Output voltage	3 x AC	V AC	0 ... U_{mains}	0 ... U_{mains}	0 ... U_{mains}
Output frequency		Hz	0 ... 400	0 ... 400	0 ... 400
Overload capacity of the continuous rated current (I_{rated})	1 s (heavy duty operation)	%	200	200	200
	1 min (heavy duty operation)	%	150	150	150
	1 min (normal duty operation)	%	–	–	120
Brake chopper/resistor					
Brake chopper	Internal		Yes	Yes	Yes
Braking resistor	External		Yes	Yes	Yes
Motor cable length (EN 61800-3 C3)	Internal/external	m	15/30	15/30	30/50
Ambient conditions					
Permitted ambient temperature (T)	Without derating	°C	–10 ... +45	–10 ... +45	–10 ... +45
Reduction in output power	For operating height from 1 000 m above sea level		1 % per 100 m	1 % per 100 m	1 % per 100 m
Relative humidity	No condensation	%	< 90	< 90	< 90
Degree of protection			IP20	IP20	IP20

Frequency converters

EFC5610



The EFC5610 enables a wide range of applications thanks to V/f control, SVC and FOC control, easy installation and commissioning and a wide power range. Demand-oriented energy supply – universal, reliable and cost-effective at any time with this frequency converter.

- ▶ **Power range: 0.4 ... 160 kW**
- ▶ **Built-in brake chopper (up to 22 kW) and net filter**
- ▶ **Control technology: V/f, SVC, FOC**
- ▶ **Safety technology: Safe Torque Off (STO)**
- ▶ **Expansion option thanks to I/O and fieldbus modules**
- ▶ **Operation of asynchronous and synchronous motors**
- ▶ **Use in HD mode (heavy duty) and ND mode (normal duty)**
- ▶ **Integrated operator panel for quick and easy commissioning**
- ▶ **Degree of protection: IP20**

Type code	
EFC5610-0K40-1P2-M D A-7P-NNNN-L1NN	
<p>Motor control</p> <p>EFC5610 = V/f, SVC and FOC control</p> <p>Continuous power</p> <p>E.g. 0K40 = 0.4 kW</p> <p>Power supply</p> <p>1P2 = 1 x AC 200 ... 240 V</p> <p>3P4 = 3 x AC 380 ... 480 V</p> <p>Fieldbus interface</p> <p>M = Modbus RTU</p>	<p style="text-align: right;">Version</p> <p style="text-align: right;">NN = Without</p> <p style="text-align: right;">L1 = Start lockout</p> <p style="text-align: right;">Display</p> <p style="text-align: right;">NN = Without (dust cover)</p> <p style="text-align: right;">7P = 7-segment LED display</p> <p style="text-align: right;">Degree of protection</p> <p style="text-align: right;">A = IP20</p> <p style="text-align: right;">B = IP20 Cold Plate</p> <p style="text-align: right;">EMC protection category</p> <p style="text-align: right;">D = Class C3 – industrial environment</p>

Available options and technical specifications: see product documentation (project planning instructions in the media directory: www.boschrexroth.com/mediadirectory)

■ For more information, please visit: www.boschrexroth.com/cat-efc5610

Functions			
Type	EFC5610		
Closed-loop control			V/f
			SVC (sensorless vector control)
			FOC (field-oriented control)
Switching frequency (PWM)	Configurable in 1 kHz steps	kHz	1 ... 15
			1 ... 12 (for variants EFC5610-110K to 160K)
Start-up torque	At 1.5 Hz (V/f) max.	%	100
	At 3 Hz (V/f) max.	%	150
	At 0.5 Hz (SVC) max.	%	200
	At 0 Hz (FOC) max.	%	200
Frequency resolution	Analog		1/1 000 of the maximum output frequency
	Digital	Hz	0.01
Frequency setting accuracy	Analog	%	±0.1
	Digital	%	±0.01
V/f curve			Freely definable
			Linear
			Square
Ramps	For acceleration and braking		Linear
			S curve
DC brake	Activation frequency	Hz	0 ... 50
	Braking time	s	0 ... 10
Automatic PWM frequency adjustment			Load-dependent adaptation of the PWM frequency
Integrated control			Integrated step-by-step switch
Controller			PID
Bus systems	Internal		Modbus
			PROFIBUS
	External		CANopen
			Sercos
			EtherCAT (CANopen profile, CoE)
			Modbus TCP
			PROFINET
			EtherNet/IP
Number of digital inputs	24 V DC (of which 1x pulse train 50 kHz)		5
Number of digital outputs	24 V DC, 50 mA (pulse train 32 kHz)		1
Number of relay outputs	230 V AC, 30 V DC, 3 A		1
Number of analog inputs	0 ... 10 V or 0 ... 20 mA		2
Number of analog outputs	0 ... 10 V or 0 ... 20 mA		1
Status messages via digital outputs			E.g. operation, command value reached (additional parameters, see technical documentation)
Display	Standard		LED, 5-digit
			Dust protection cover
	Option		Dust cover with 5 diagnostic LEDs
			LCD
Status LED			Rotational direction, operating state
Safety technology	Option		Safe Torque Off (STO, SIL 3 PL e)

EFC5610

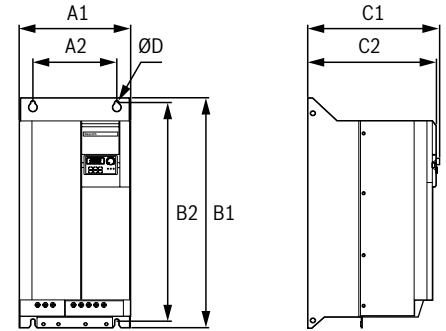

■ For more information, please visit: www.boschrexroth.com/cat-efc5610

Power data 1					Dimensions							
Type	Heavy duty operation		Normal duty operation		A1	A2	B1	B2	C1	C2	ØD	Mass
	Rated power	Continuous rated current	Nominal power	Continuous rated current								
	P _{rated} kW	I _{rated} A	P _{rated} kW	I _{rated} A								m kg
EFC5610-0K40-1P2	0.40	2.4	–	–	95	66	166	156	167	159	4.5	1.5
EFC5610-0K75-1P2	0.75	4.1	–	–	95	66	166	156	167	159	4.5	1.5
EFC5610-1K50-1P2	1.50	7.3	–	–	95	66	206	196	170	162	4.5	1.9
EFC5610-2K20-1P2	2.20	10.1	–	–	120	80	231	221	175	167	4.5	2.6
EFC5610-0K40-3P2	0.40	2.4	–	–	95	66	166	156	167	159	4.5	1.5
EFC5610-0K75-3P2	0.75	4.1	–	–	95	66	206	196	170	162	4.5	1.9
EFC5610-1K50-3P2	1.50	7.3	–	–	120	80	231	221	175	167	4.5	2.6
EFC5610-2K20-3P2	2.20	10.1	–	–	120	80	231	221	175	167	4.5	2.6
EFC5610-3K00-3P2	3.00	13.4	–	–	130	106	243	228	233	225	6.5	3.9
EFC5610-4K00-3P2	4.00	17.5	–	–	130	106	243	228	233	225	6.5	4.3
EFC5610-5K50-3P2	5.50	23.4	–	–	150	125	283	265	233	225	6.5	5.7
EFC5610-7K50-3P2	7.50	31.1	–	–	150	125	283	265	233	225	6.5	6.4
EFC5610-11K0-3P2	11.00	44.9	–	–	165	140	315	300	241	233	6.5	8.5
EFC5610-0K40-3P4	0.40	1.3	–	–	95	66	166	156	167	159	4.5	1.5
EFC5610-0K75-3P4	0.75	2.3	–	–	95	66	166	156	167	159	4.5	1.5
EFC5610-1K50-3P4	1.50	4.0	–	–	95	66	206	196	170	162	4.5	1.9
EFC5610-2K20-3P4	2.20	5.6	–	–	95	66	206	196	170	162	4.5	1.9
EFC5610-3K00-3P4	3.00	7.4	–	–	120	80	231	221	175	167	4.5	2.6
EFC5610-4K00-3P4	4.00	9.7	–	–	120	80	231	221	175	167	4.5	2.6
EFC5610-5K50-3P4	5.50	12.7	7.5	16.8	130	106	243	228	233	225	6.5	3.9
EFC5610-7K50-3P4	7.50	16.8	11.0	24.3	130	106	243	228	233	225	6.5	4.3
EFC5610-11K0-3P4	11.00	24.3	15.0	32.4	150	125	283	265	233	225	6.5	5.7
EFC5610-15K0-3P4	15.00	32.4	18.5	39.2	150	125	283	265	233	225	6.5	6.4
EFC5610-18K5-3P4	18.50	39.2	22.0	45.0	165	140	315	300	241	233	6.5	8.0
EFC5610-22K0-3P4	22.00	45.0	30.0	60.8	165	140	315	300	241	233	6.5	8.5
EFC5610-30K0-3P4	30.00	60.8	37.0	73.7	250	200	510	492	272	264	7.0	27.5
EFC5610-37K0-3P4	37.00	73.7	45.0	89.1	250	200	510	492	272	264	7.0	29.5
EFC5610-45K0-3P4	45.00	89.0	55.0	108.0	265	200	585	555	325	317	11.0	39.0
EFC5610-55K0-3P4	55.00	108.0	75.0	147.0	265	200	585	555	325	317	11.0	42.0
EFC5610-75K0-3P4	75.00	147.0	90.0	176.0	325	200	760	727	342	334	11.0	54.0
EFC5610-90K0-3P4	90.00	176.0	110.0	212.0	325	200	760	727	342	334	11.0	61.0
EFC5610-110K-3P4	110.00	212.0	132.0	253.0	385	250	923	893	350	342	11.0	71.7
EFC5610-132K-3P4	132.00	253.0	160.0	303.0	385	250	923	893	350	342	11.0	76.6
EFC5610-160K-3P4	160.00	303.0	200.0	380.0	480	400	1030	995	360	352	13.0	108.0

Power data 2									
Type			EFC5610-0K40-1P2	EFC5610-0K40-3P2	EFC5610-3K00-3P2	EFC5610-0K40-3P4	EFC5610-5K50-3P4	EFC5610-30K0-3P4	EFC5610-110K-3P4
		
			EFC5610-2K20-1P2	EFC5610-2K20-3P2	EFC5610-11K0-3P2	EFC5610-4K00-3P4	EFC5610-22K0-3P4	EFC5610-90K0-3P4	EFC5610-160K-3P4
Connection data									
Power supply voltage (U _{mains})	1 x AC	V AC	200 ... 240	–	–	–	–	–	–
	3 x AC	V AC	–	200 ... 240	200 ... 240	380 ... 480	380 ... 480	380 ... 480	380 ... 480
Tolerance of the power supply voltage		%	±10	±10	±10	-15 ... +10	-15 ... +10	-15 ... +10	-15 ... +10
Mains frequency (f _{mains})		Hz	50 ... 60	50 ... 60	50 ... 60	50 ... 60	50 ... 60	50 ... 60	50 ... 60
Tolerance of the mains frequency		%	±5	±5	±5	±5	±5	±5	±5
Output voltage	3 x AC	V AC	0 ... U _{mains}	0 ... U _{mains}	0 ... U _{mains}	0 ... U _{mains}	0 ... U _{mains}	0 ... U _{mains}	0 ... U _{mains}
Output frequency		Hz	0 ... 400	0 ... 400	0 ... 400	0 ... 400	0 ... 400	0 ... 400	0 ... 400
Overload capacity of the continuous rated current (I _{rated})	1 s (heavy duty operation)	%	200	200	200	200	200	200	200
	1 min (heavy duty operation)	%	150	150	150	150	150	150	150
	1 min (normal duty operation)	%	–	–	–	–	120	120	120
Brake chopper/resistor									
Brake chopper	Internal		Yes	Yes	Yes	Yes	Yes	No	No
Braking resistor	External		Yes	Yes	Yes	Yes	Yes	Yes	Yes
Motor cable length (EN 61800-3 C3)	Internal/external	m	15/30	15/50	30/50	15/30	30/50	50/100	75/150
Ambient conditions									
Permitted ambient temperature (T)	Without derating	°C	-10 ... +45	-10 ... +45	-10 ... +45	-10 ... +45	-10 ... +45	-10 ... +45	-10 ... +45
Reduction in output power	For operating height from 1 000 m above sea level		1 % per 100 m	1 % per 100 m	1 % per 100 m	1 % per 100 m	1 % per 100 m	1 % per 100 m	1 % per 100 m
Relative humidity	No condensation	%	< 90	< 90	< 90	< 90	< 90	< 90	< 90
Degree of protection			IP20	IP20	IP20	IP20	IP20	IP20	IP20

Servo drives

With servo drives from Bosch Rexroth, all motion tasks of modern factory automation can be realized – whether in the watt or megawatt range, whether with or without control cabinet. Bosch Rexroth servo drives offer everything

for economical and future-proof machine automation: integrated hardware and software platform, Multi-Ethernet-based communication, certified safety technology and much more.



IndraDrive	208
Combination options	208
IndraDrive Mi	
Cabinet-free drive technology	210
Motor-integrated servo drive IndraDrive Mi – KSM02	216
Near motor servo drive IndraDrive Mi – KMS02	218
Near motor servo drive IndraDrive Mi – KMS03	220
Control electronics IndraDrive Mi – KCU02	222
Supply module IndraDrive Mi – KMV03	224
Mains module IndraDrive Mi – KNK03	226
Capacity module IndraDrive Mi – KLC03	228
IndraDrive	
Cabinet-based drive technology	230
IndraDrive power units	
Compact converters IndraDrive Cs – HCS01	232
Single-axis converters IndraDrive C – HCS02	236
Single-axis converters IndraDrive C – HCS03	238
Multi-axis converters IndraDrive C – HCT02/HCQ02	240
Supply unit IndraDrive M – H MV01	242
Single-axis inverter IndraDrive M – HMS01	246
Double-axis inverter IndraDrive M – HMD01	250
Supply unit IndraDrive M – H MV02	252
Single-axis inverter IndraDrive M – HMS02	254
Universal inverters IndraDrive ML – H MU05	256
IndraDrive control units	
BASIC single-axis control unit IndraDrive – CSB02	266
BASIC double-axis control unit IndraDrive – CDB02	268
ADVANCED single-axis control unit IndraDrive – CSH02	270
IndraDrive software	272
Drive software IndraDrive – MPx/PSB	274
IndraDrive safety technology	280
SafeMotion IndraDrive	282

IndraDrive

Combination options

The large power range of the IndraDrive from 100 W to 4 MW and the unique combinability of the units enable users inside to always use the optimum topology.

Cabinet-based system

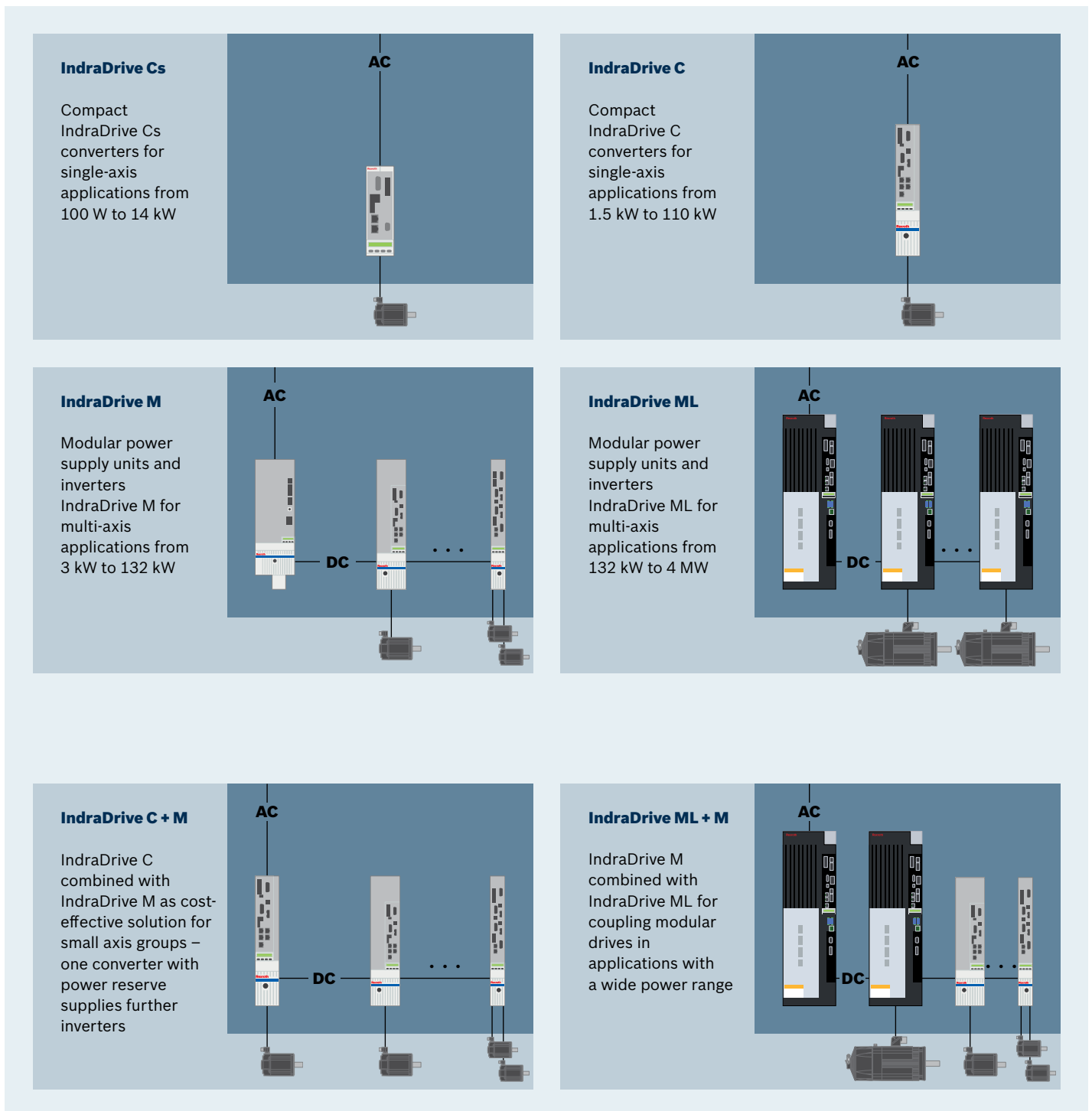

Cabinet-reduced system

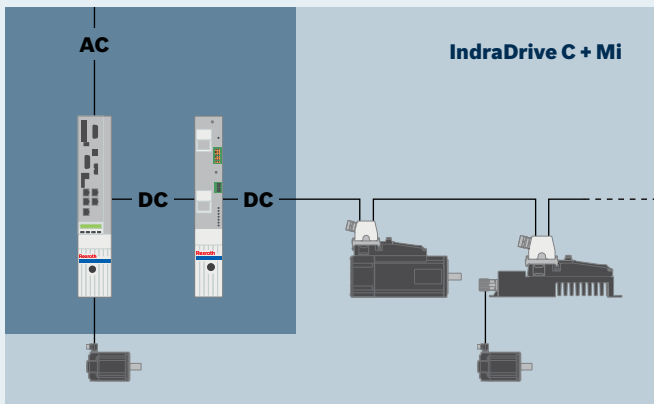
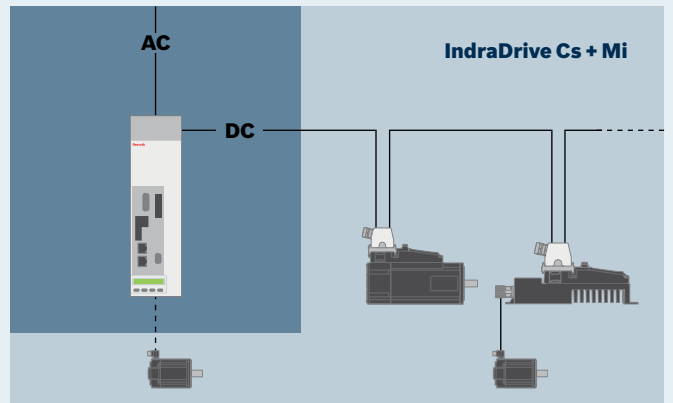
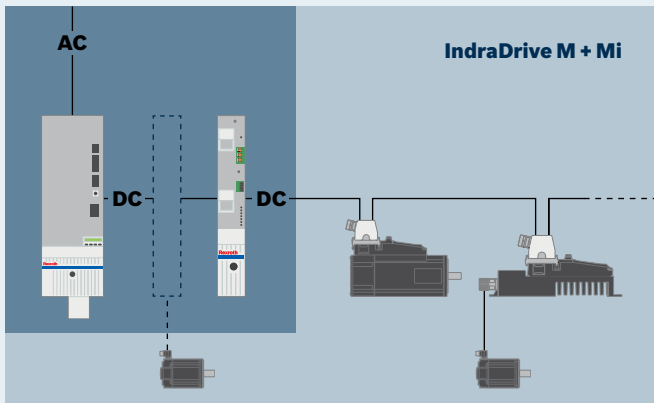

IndraDrive M/C/Cs + Mi

IndraDrive Mi combined with IndraDrive M/C/Cs for use of cabinet-based drives with power reserve as a supply for decentralized drives

Cabinet-free system

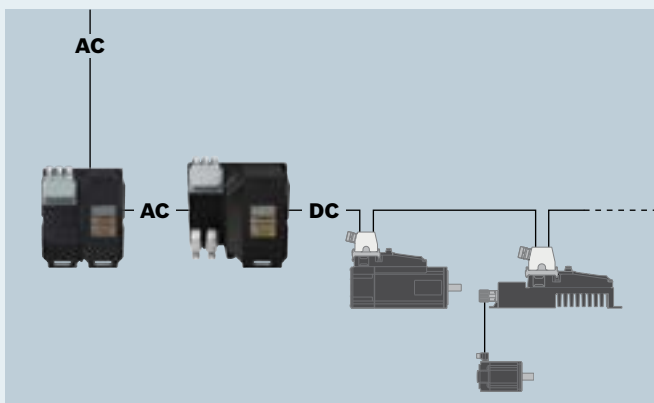

IndraDrive Mi

IndraDrive Mi as a decentralized drive solution for multi-axis applications from 0.4 kW to 11 kW – completely without control cabinet

IndraDrive Mi

Cabinet-free drive technology

Greater flexibility, less wiring and new possibilities for modularization: The IndraDrive Mi from Bosch Rexroth provides machine manufacturers with servo drive technology without control cabinets for placement on or in the machine. This reduces the need for control cabinets by 100 percent and wiring costs by up to 90 percent. In addition, cabinet-free drive technology extends the flexibility for modularized machine concepts and simplifies automation through open communication standards, predefined technology packages and free programming in high-level languages. The Open Core Interface for Drives enables direct access to the drive parameters via high-level language-based applications.

- ▶ **Reduce wiring by 90 percent, optimize energy balance**
- ▶ **Reduce the need for control cabinets by up to 100 percent**
- ▶ **Reduce the need for cooling by up to 100 percent**



- ▶ **KMS02/03**
Near motor servo drive
The KMS near motor servo drive allow a wide variety of motors to be integrated into an IndraDrive Mi chain of drive.



- ▶ **KCU02**
Control electronics
The compact KCU control electronics provides all the necessary connections for the IndraDrive Mi chain of drive to a common connection point.



▶ **KSM02**

Motor-integrated servo drive

The compact power and control electronics of the KSM motor-integrated servo drive uses the case surface of a servo motor as cooling element.



▶ **KMV03**

Supply module

The feed-in and regenerative module is equipped with an integrated brake chopper, braking resistor and a 24/42 V DC converter.



▶ **KLC03**

Capacity module

The KLC03 module is used to prevent peak loads in the supply network and allows storing of energy for retraction movements in the event of a power failure.



▶ **KNK03**

Mains module

For direct power supply from the power grid. With integrated net filter, mains choke and network contactor. Suitable for connecting the supply module KMV.

IndraDrive Mi

All advantages at a glance

The IndraDrive Mi enables machine manufacturers to integrate all electric drive components directly into the machine. The result is modular machines without any control cabinets and with minimized space requirements.

Energy-efficient power supply

- ▶ Compatible and freely combinable with the IndraDrive drive system
- ▶ Energy exchange through use of the common DC bus, power recovery, energy buffering

Intelligent communication

- ▶ Supports all relevant Ethernet-based communication protocols (Sercos, PROFINET IO, EtherNet/IP, EtherCAT)
- ▶ Uniform hardware, protocol selection via software
- ▶ Communication decoupling for integration of sensors and actuators (I/O, pneumatics, hydraulics, third party)



Time-saving installation

- ▶ Reducing the need for control cabinets by up to 100 percent
- ▶ Up to 90 percent less wiring with hybrid cable technology for power supply and communication
- ▶ Reducing the need for cooling by up to 100 percent
- ▶ Simple drive chain expansion with hybrid cable technology

Flexible control functions

- ▶ Drive-integrated motion logic for axis-related tasks
- ▶ Ready-made, industry-specific technology functions for fast parameterization
- ▶ Programming in accordance with IEC 61131-3

Drive-integrated safety technology to protect man, machine, and work piece

- ▶ Safe Torque Off
- ▶ Safe Motion functions via safety control

Optimal design

- ▶ Easy to clean
- ▶ Degree of protection IP65
- ▶ Different hybrid cables for easy wiring or limited space conditions
- ▶ Options for rotating machines with slip ring transmission
- ▶ Version for potentially explosive environments (ATEX)

Application-optimized concept for energy-efficient production

- ▶ DC bus capacities (KLC) as dynamic energy storage in combination with Smart Energy Mode

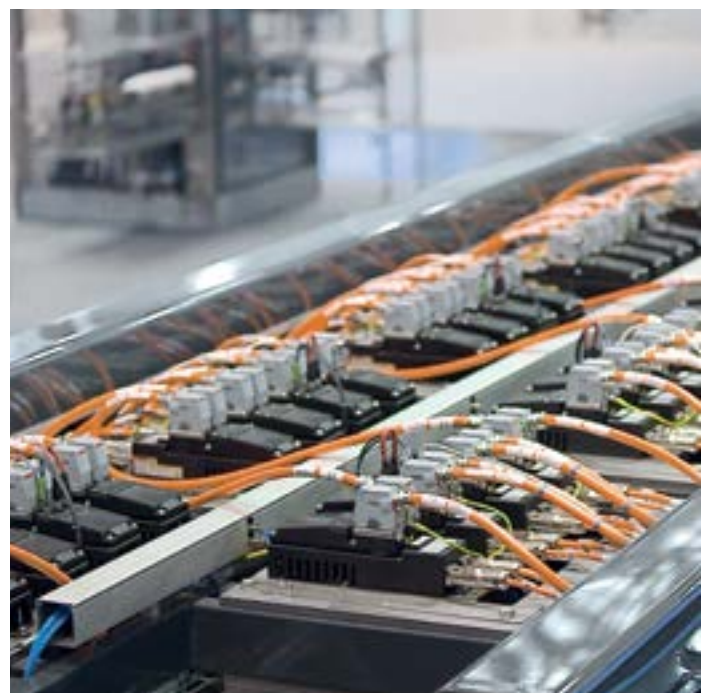

IndraDrive Mi

The system design: as simple as it is economical

The unique system design of the IndraDrive Mi drive solution is the key to high economic efficiency and flexibility. You can implement your drive technology completely independently and without a control cabinet, because all system components are designed in IP65. Or you can use converters and supply modules in the control cabinet and supply up to 30 drives on one chain with one control electronics.

Cabinet-reduced system

The cabinet-reduced variant uses an existing converter (HCS) or modular supply unit (HMV) to provide power. A DC bus coupling for optimum energy exchange between the generator and motor axes is always provided. For operation, IndraDrive Mi only requires an electronic control unit (KCU), which is located in the control cabinet next to a supply unit. It provides and secures the voltage and communication supply for a chain of drive with up to 30 participants. Additional IndraDrive Mi chains, each up to 200 meters long, can be integrated via additional control electronics (KCU).

Cabinet-free system

However, the IndraDrive Mi system can also be used to implement a completely self-sufficient drive solution without a control cabinet. The mains module (KNK) is connected directly to the power grid. The supply module (KMV) replaces the regenerative supply and the control electronics in the control cabinet. The complete drive system can thus be integrated directly into the machine. All power supply components (net filter, network contactor, mains choke, supply unit) currently still in the control cabinet are omitted.

A hybrid cable supplies the drives connected in series in daisy-chain style. Distribution boxes are not required. The motor-integrated servo drives (KSM) consist of a Bosch Rexroth servo motor with an integrated inverter. Cooling takes place via the motor surface. If the installation space is very limited or motors without integrated inverter electronics have to be integrated, near motor servo drive (KMS) are used. The separate inverter electronics are installed decentrally in the machine and connected to the motor.

The result:

- ▶ 100 percent cabinet-free
- ▶ 100 percent flexible

Conventional system

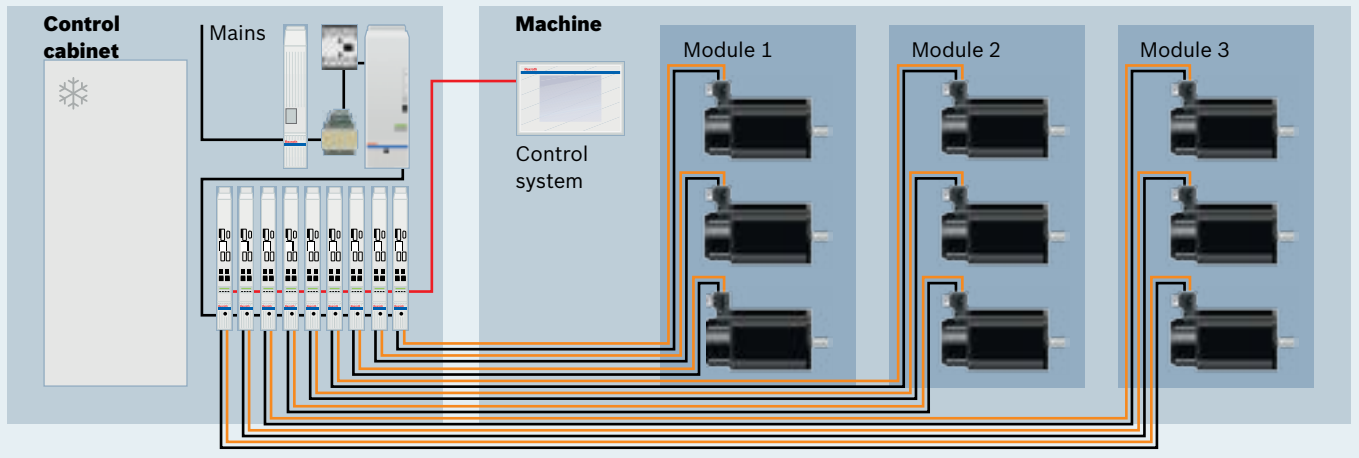

Cabinet-reduced system

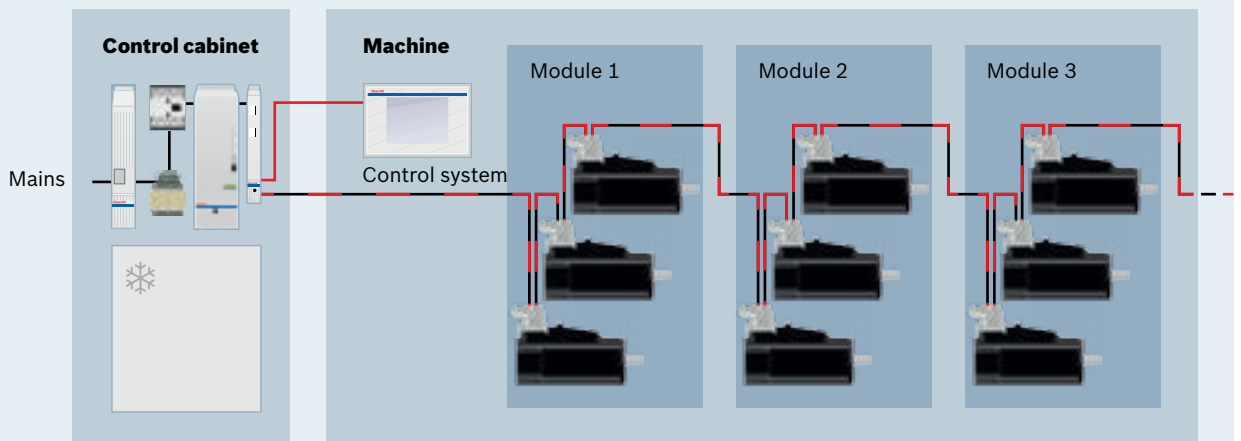

Cabinet-free system

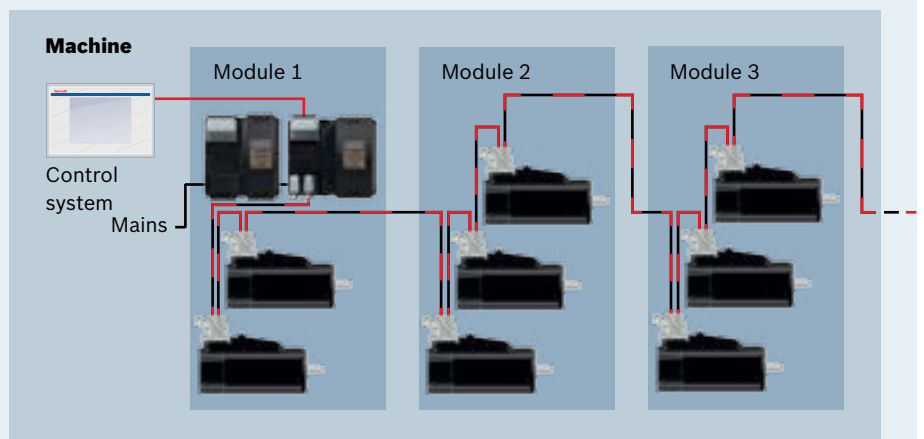

Motor-integrated servo drive

IndraDrive Mi

KSM02



The motor-integrated KSM02 servo drive consists of a synchronous servo motor with integrated inverter, control electronics and firmware. The DC voltage supply and communication take place via a hybrid cable, which connects the components in daisy-chain style. The components are cooled by convection through the motor surface.

- ▶ **Power range: 0.4 ... 1.2 kW**
- ▶ **Continuous torques: 2.2 ... 10.5 Nm**
- ▶ **Maximum torques: 9.4 ... 35 Nm**
- ▶ **DC bus voltage: 540 ... 750 V**
- ▶ **Degree of protection: IP65**

Type code	
KSM02.1B-061C-35N-M1-HP 0-ET-NN-D7-NN-FW	
<p>Basic motor</p> <ul style="list-style-type: none"> ▶ Frame size (e.g. "061") ▶ Frame length (e.g. "C") ▶ Winding (e.g. "35") <p>Encoder</p> <p>S1 = Single-turn, Hiperface, 128 signal periods S3 = Single-turn, Hiperface, 16 signal periods M1 = Multi-turn, 4 096 rotations, Hiperface, 128 signal periods M3 = Multi-turn, 4 096 rotations, Hiperface, 16 signal periods</p> <p>Shaft</p> <p>P = Keyway G = Smooth shaft</p> <p>Holding brake</p> <p>0 = Without holding brake 2 = Electrical release holding brake (DC 24 V)</p>	<p style="text-align: right;">Other version</p> <p>NN = None ES = External control communication TO = Uncoupling control communication AN = ATEX version AE = ATEX version, External control communication AT = ATEX version, Decoupling of control communication</p> <p style="text-align: right;">Line voltage</p> <p>D7 = DC 750 V T = With temperature monitoring</p> <p style="text-align: right;">Safety technology</p> <p>NN = Without L3 = Safe Torque Off (STO) S3 = Safe Motion (without SBC) SD = Safe Motion</p>

Available options and technical specifications: see product documentation (project planning instructions in the media directory: www.boschrexroth.com/mediadirectory)

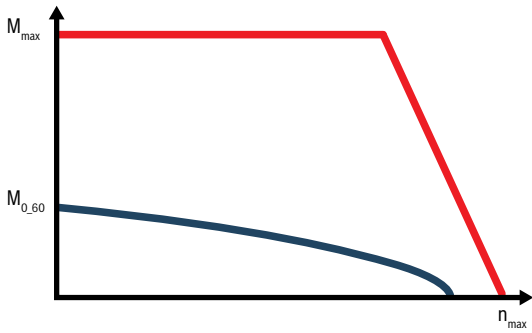

■ For more information, please visit: www.boschrexroth.com/cat-ksm02

Technical specifications

Type			KSM02.1B-041C-42	KSM02.1B-061C-35	KSM02.1B-061C-61	KSM02.1B-071C-24	KSM02.1B-071C-35	KSM02.1B-076C-35
Maximum speed	n_{max}	min ⁻¹	5 500	4 300	6 000	3 400	4 700	4 700
Standstill torque 60K	$M_{0,60}$	Nm	2.2	6.0	5.5	10.5	10.0	8.7
Maximum torque	M_{max}	Nm	9.4	25.0	18.0	35	28	29
Continuous standstill current	I_0	A	1.5	3.3	5.2	4.6	6.0	5.2
Maximum current	I_{max}	A	6.8	14.9	17.7	17.7	17.7	17.7
Moment of inertia without brake	J	kg·m ²	0.00017	0.00087	0.00087	0.00173	0.00173	0.0043
Moment of inertia with brake	J	kg·m ²	0.00019	0.00093	0.00093	0.00189	0.00189	0.00446

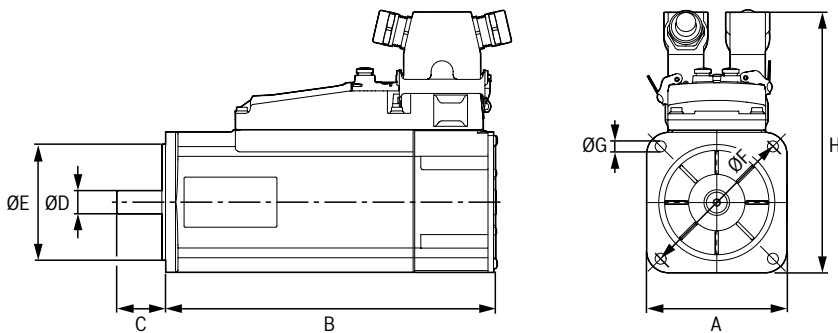

Dimensions

Type			KSM02.1B-041C-42	KSM02.1B-061C-35	KSM02.1B-061C-61	KSM02.1B-071C-24	KSM02.1B-071C-35	KSM02.1B-076C-35
A	mm		82	115	115	140	140	140
B	mm		252	271	271	307	307	290
C	mm		30	40	40	58	58	50
ØD	mm		14	19	19	32	32	24
ØE	mm		50	95	95	130	130	110
ØF	mm		95	130	130	165	165	165
ØG	mm		6.6	9	9	11	11	11
H	mm		194	219	219	247	247	247
Mass without brake	kg		5.6	9.6	9.6	14.1	14.1	14.6
Mass with brake	kg		5.9	10.1	10.1	15.2	15.2	15.7

Near motor servo drive

IndraDrive Mi

KMS02



The KMS02 near motor servo drive is a decentralized inverter including control electronics and firmware. The DC voltage supply and communication take place via a hybrid cable, which connects the components in daisy-chain style. Both asynchronous and synchronous motors (rotary and linear) can be operated on KMS02.

- ▶ **Power: 2.2 kW**
- ▶ **Continuous current: 5.8 A**
- ▶ **Maximum current: 18 A**
- ▶ **DC bus voltage: 540 ... 750 V**
- ▶ **Degree of protection: IP65**
- ▶ **Ideal for integration of other Bosch Rexroth servo motors or of 3rd-party motors (with/without encoder)**

Type code	
KMS02.1B-A018-P-D7-ET-ENH-L3-TO-FW	
<p>Maximum current</p> <p>018 = 18 A</p> <p>Rated DC bus voltage</p> <p>D7 = DC 750 V</p> <p>S3 = Single-turn, Hiperface, 16 signal periods</p> <p>S1 = Multi-turn, 4 096 rotations, Hiperface, 128 signal periods</p> <p>S1 = Multi-turn, 4 096 rotations, Hiperface, 16 signal periods</p> <p>Encoder interface</p> <p>ENH = HIPERFACE®</p> <p>ENA = ACURO®link</p> <p>NNN = Without</p> <p>Safety technology</p> <p>NN = Without</p> <p>L3 = Safe Torque Off (STO)</p> <p>S3 = Safe Motion (without SBC)</p> <p>SD = Safe Motion</p>	<p style="text-align: right;">Other version</p> <p style="text-align: right;">NN = None</p> <p style="text-align: right;">ES = External control communication</p> <p style="text-align: right;">TO = Uncoupling control communication</p> <p style="text-align: right;">AN = ATEX version</p> <p>WN = angle plug (motor and encoder connection)</p> <p>WE = angle plug (motor and encoder connection), external control communication</p> <p>WT = angle plug (motor and encoder connection), uncoupling control communication</p>

Available options and technical specifications: see product documentation (project planning instructions in the media directory: www.boschrexroth.com/mediadirectory)

■ For more information, please visit: www.boschrexroth.com/cat-kms02

Technical specifications			
Type	KMS02.1B-A018		
Degree of protection – overall	IP65		
Type of cooling	Natural convection (external heat sink)		
DC bus			
Input voltage	V DC	540 ... 750	
DC bus capacity	mF	0.02	
Inverter			
Switching frequency/max. output frequency	4 kHz	Hz	0 ... 400
	8 kHz	Hz	0 ... 800
Output voltage	DC bus voltage x 0.71		
Continuous current	A	5.8	
Maximum current	A	18	

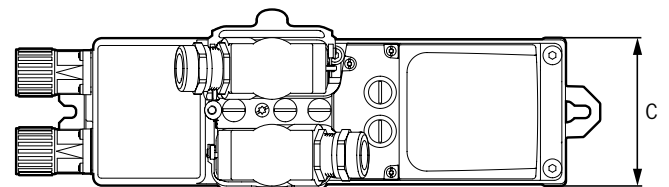
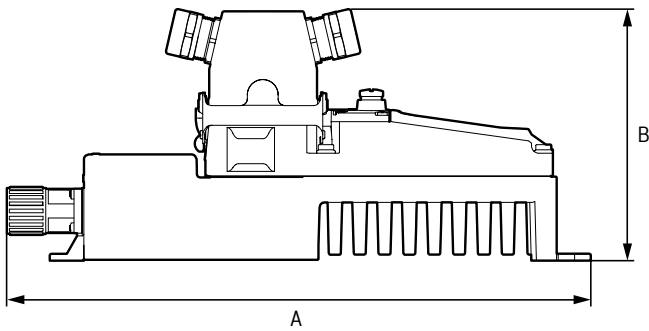

Dimensions		
Type	KMS02.1B-A018	
A	mm	341
B	mm	147
C	mm	86
Mass	kg	2.5

Near motor servo drive

IndraDrive Mi

KMS03



The KMS03 near motor servo drive are decentralized inverters including control electronics and firmware. The DC voltage supply and communication take place via a hybrid cable, which connects the components in daisy-chain style. Both asynchronous and synchronous motors (rotary and linear) can be operated on the KMS03. Depending on the size, a thermal interface for cold plate mounting is also available in addition to convection cooling.

- ▶ **Power range: 5.5 ... 11 kW**
- ▶ **Continuous currents: 12 ... 22 A**
- ▶ **Maximum current: 36 A**
- ▶ **DC bus voltage: 540 ... 750 V**
- ▶ **Degree of protection: IP65**
- ▶ **Ideal for integration of other Bosch Rexroth servo motors or 3rd-party motors (with/without encoder)**

Type code	
KMS03.1B-A 036-P-D7-ET-END-L3-TO-FW	
<p>Type of cooling</p> <p>A = Keyway B = Cold plate</p> <p>Maximum current</p> <p>036 = 36 A</p> <p>Rated DC bus voltage</p> <p>D7 = DC 750 V</p> <p>Encoder interface</p> <p>END = HIPERFACE® and digital encoder</p>	<p>Other version</p> <p>NN = None ES = External control communication TO = Uncoupling control communication</p> <p>Safety technology</p> <p>NN = Without L3 = Safe Torque Off (STO) SD = Safe Motion</p>

Available options and technical specifications: see product documentation (project planning instructions in the media directory: www.boschrexroth.com/mediadirectory)

■ For more information, please visit: www.boschrexroth.com/cat-kms03

Technical specifications				
Type			KMS03.1B-A036	KMS03.1B-B036
Degree of protection – overall			IP65	IP65
Type of cooling			Natural convection	Thermal interface for cold plate mounting
DC bus				
Input voltage	V DC		540 ... 750	540 ... 750
DC bus capacity	mF		0.05	0.05
Inverter				
Switching frequency/max. output frequency	4 kHz	Hz	0 ... 400	0 ... 400
	8 kHz	Hz	0 ... 800	0 ... 800
Output voltage			DC bus voltage x 0.71 V	
Continuous current	A		12	22
Maximum current	A		36	36

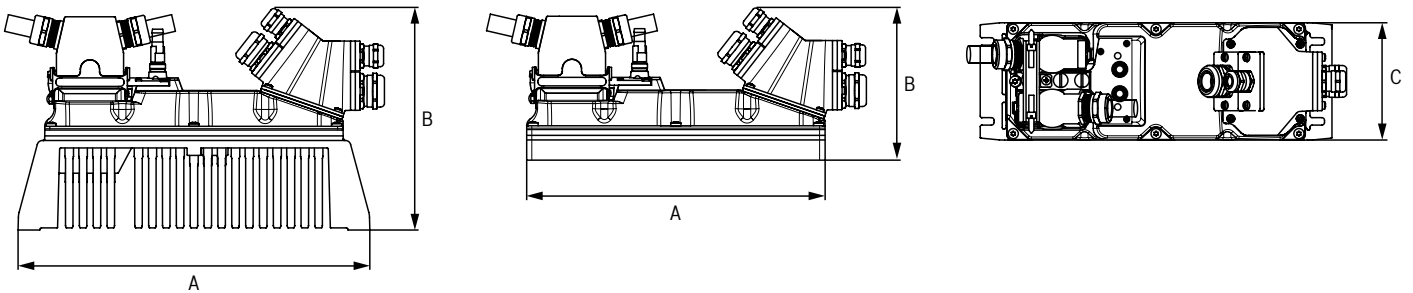

Dimensions				
Type			KMS03.1B-A036	KMS03.1B-B036
A	mm		344	320
B	mm		209	144
C	mm		110	110
Mass	kg		4.0	3.4

Control electronics

IndraDrive Mi

KCU02



The KCU02 control electronics provide all the necessary connections for connecting the IndraDrive Mi chain of drive to a common connection point. A KCU is only necessary when the control cabinet already has an available power supply. Both HMV supply units and HCS converters can be used as power supply units. If required, it is also possible to connect several KCU02 control electronics to a single power supply in order to run several IndraDrive Mi drive chains in parallel.

- ▶ **Power: 18.8 kW**
- ▶ **Continuous current: 25 A**
- ▶ **Maximum current: 71 A**
- ▶ **DC bus voltage: 540 ... 750 V**
- ▶ **Degree of protection: IP20**

Type code

KCU02.2N-ET-ET*-025-NN-N-NN-NW

DC fuse

025 = Rated current 25 A

Available options and technical specifications: see product documentation (project planning instructions in the media directory: www.boschrexroth.com/mediadirectory)

■ For more information, please visit: www.boschrexroth.com/cat-kcu02

Technical specifications		
Type	KCU02.1N-ET-ET	
Degree of protection – overall	IP20	
Type of cooling	Forced ventilation	
DC bus		
Continuous power	kW	14 ... 18.8
Max. power	kW	42 ... 53.3
DC bus capacity	mF	< 0.001
DC bus voltage U_{DC}	V	540 ... 750
Control voltage		
Internal control voltage	V	42 (+10 %)
Power consumption	W	675

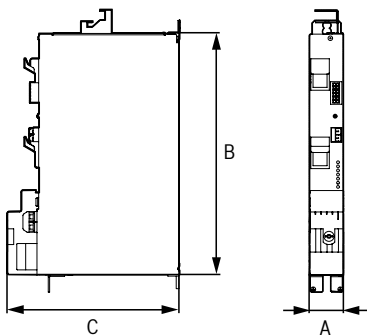

Dimensions		
Type	KCU02.2N-ET-ET	
A	mm	50
B	mm	352
C	mm	252
Mass	kg	3.8

Supply module

IndraDrive Mi

KMV03



The supply module KMV03 generates a DC bus voltage from the supply voltage and makes it available to the connected servo drives near and integrated in the motor. In addition to being able to feed excess energy back into the supply network, it regulates the DC bus voltage at a constant level. It includes an emergency brake transistor and resistor. Types of cooling include a thermal interface for cold-plate mounting, an insulated design, convection cooling and forced air ventilation.

- ▶ **Power range: 1.5 ... 7.5 kW**
- ▶ **Power supply voltage: 380 ... 500 V**
- ▶ **Degree of protection: IP65**
- ▶ **Energy direction: feeding and regenerating**

Type code	
KMV03.1R-B 0007-P-D7-ET-NNNN-FW	
Type of cooling	Rated DC bus voltage
I = Insulated design	D7 = DC 750 V
A = Convection	
W = Air cooling	Rated power
B = Cold plate	E.g. 0007 = 7.5 kW

Available options and technical specifications: see product documentation (project planning instructions in the media directory: www.boschrexroth.com/mediadirectory)

■ For more information, please visit: www.boschrexroth.com/cat-kmv03

Technical specifications					
Type		KMV03.1R-B	KMV03.1R-I	KMV03.1R-A	KMV03.1R-W
Degree of protection – overall		IP65	IP65	IP65	IP65
Type of cooling		Thermal interface (cold plate mounting)	Thermal interface (insulated design)	Natural convection (external heat sink)	Forced cooling (external heat sink, attached fan)
Power data					
Power supply voltage 3 AC	V	380 ... 500	380 ... 500	380 ... 500	380 ... 500
Mains frequency	Hz	50 ... 60	50 ... 60	50 ... 60	50 ... 60
DC bus					
DC bus voltage U_{DC}	V	750	750	750	750
Continuous power in the DC bus P_{Cont}	kW	7.5	1.5	5	6
Maximum DC bus power P_{max}	kW	15	15	15	15
Braking resistor continuous power	kW	0.15	0.15	0.15	0.15
Braking resistor maximum power	kW	13.5	13.5	13.5	13.5

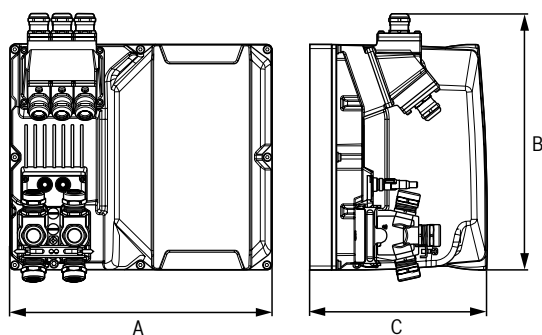

Dimensions					
Type		KMV03.1R-B	KMV03.1R-I	KMV03.1R-A	KMV03.1R-W
A	mm	325	325	330	330
B	mm	318	318	360	360
C	mm	220.5	220.5	280	280
Mass	kg	15.7	15.7	20	20

Mains module

IndraDrive Mi

KNK03



The KNK03 mains module includes all necessary mains connection components, such as net filter, mains choke and mains contactor, in one enclosure. Suitable type of cooling and power for connection of the supply modules KMV. It includes an emergency brake transistor and resistor. Types of cooling include a thermal interface for cold-plate mounting, an insulated design, convection cooling and forced air ventilation.

- ▶ **Power range: 1.5 ... 7.5 kW**
- ▶ **Power supply voltage: 380 ... 500 V**
- ▶ **Degree of protection: IP65**

Type code	
KNK03.1A-NR-B 0012-P-U226-A4-NNNN	
<p>EMC area</p> <p>A = Category C3 according to DIN 61800-3</p> <p>Type of cooling</p> <p>I = Insulated design</p> <p>A = Convection</p> <p>W = Air cooling</p> <p>B = Cold plate</p> <p>Rated current</p> <p>E.g. 0012 = 12 A</p>	<p>Power supply voltage</p> <p>A4 = 3 x AC 380 ... 500 V</p> <p>Leakage capacity</p> <p>U226 = 226 nF</p>

Available options and technical specifications: see product documentation (project planning instructions in the media directory: www.boschrexroth.com/mediadirectory)

■ For more information, please visit: www.boschrexroth.com/cat-knk03

Technical specifications						
Type			KNK03.1A-NR-B	KNK03.1A-NR-I	KNK03.1A-NR-A	KNK03.1A-NR-W
Degree of protection – overall			IP65	IP65	IP65	IP65
Type of cooling			Thermal interface (cold plate assembly)	Thermal interface (insulated assembly)	Natural convection (external heat sink)	Forced cooling (external heat sink, attached fan)
Power data						
Power supply voltage	3 AC	V	380 ... 500	380 ... 500	380 ... 500	380 ... 500
Mains frequency		Hz	50 ... 60	50 ... 60	50 ... 60	50 ... 60
Power supply continuous current		A	12	2.3	8.1	9.5

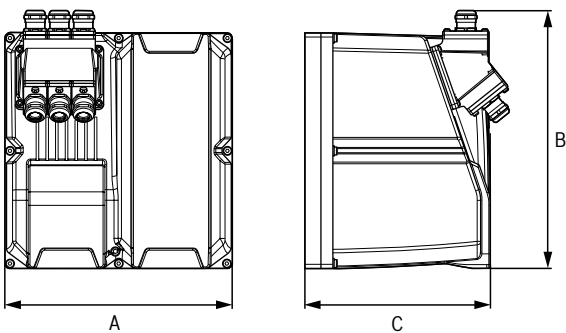

Dimensions						
Type			KNK03.1A-NR-B	KNK03.1A-NR-I	KNK03.1A-NR-A	KNK03.1A-NR-W
A	mm		270	270	274	274
B	mm		306	306	360	360
C	mm		243	243	283	283
Mass	kg		20	20	24	24

Capacity module

IndraDrive Mi

KLC03



The KLC03 capacity module is used to prevent peak loads on the mains side. In addition, it enables energy to be stored for retraction movements after a power failure and allows peak power to be increased within the DC bus.

- ▶ **DC bus voltage: 540 ... 750 V**
- ▶ **Degree of protection: IP65**

Type code	
KLC03.1N-B 04M7-P-D7-NNNN	
Type of cooling A = Convection W = Air cooling B = Cold plate	Rated DC bus voltage D7 = DC 750 V
Rated capacity 04M7 = 4.7 mF	

Available options and technical specifications: see product documentation (project planning instructions in the media directory: www.boschrexroth.com/mediadirectory)

■ For more information, please visit: www.boschrexroth.com/cat-klc03

Technical specifications				
Type		KLC03.1-B	KLC03.1-A	KLC03.1-W
Type of cooling		Thermal interface (cold plate assembly)	Natural convection (external heat sink)	Forced cooling (external heat sink, attached fan)
DC bus voltage U_{DC}	V	540 ... 750	540 ... 750	540 ... 750
DC bus capacity U_{DC}	mF	4.7	4.7	4.7

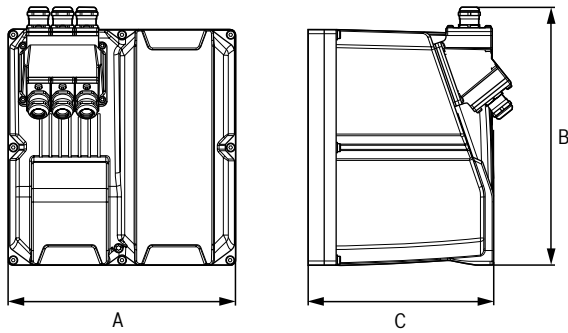

Dimensions				
Type		KLC03.1-B	KLC03.1-A	KLC03.1-W
A	mm	270	274	274
B	mm	306	360	360
C	mm	243	283	283
Mass	kg	12	17	17

IndraDrive

Cabinet-based drive technology

The IndraDrive Cs, C, M and ML control cabinet drives solve automation applications in a technically and economically optimum manner. Consistent separation of power and function enables servo and frequency converter applications on an integrated hardware platform – all in a wide power range. The drive software base packages contain all basic functions. More than one hundred easily parameterizable technology functions facilitate the realization of process-oriented tasks without programming knowledge. The drive-integrated motion logic with IEC-conform PLC relies on open standards, which facilitates the integration of know-how and saves time and money. When communicating with the control or peripheral devices, the control cabinet drives use internationally recognized interfaces. The most advanced safety functions are on-board with IndraDrive.

- ▶ **Complete, scalable converter, inverter and supply program**
- ▶ **Direct power supply and power recovery**
- ▶ **Wide performance range from 100 W to 4 MW**
- ▶ **Open communication via Multi-Ethernet interfaces**
- ▶ **Integrated motion logic with PLC as per IEC 61131-3**
- ▶ **Certified safety functions according to IEC 61508 (SIL3) and EN ISO 13849-1 (Cat. 4, PL e) for safe stop and safe movement**

- ▶ **IndraDrive C HCS02 and HCS03**
Space-saving converter for single-axis applications

- ▶ **IndraDrive Cs HCS01**
Ultra-compact converters for small powers

- ▶ **IndraDrive C HCT/HCQ**
Three- and four-axis inverters for use in machine tools – combinable with CNC system MTX micro



▶ **IndraDrive M
HMS01 and HMS02**

Single-axis inverter for the realization of modular multi-axis applications

▶ **IndraDrive M
HVM01 and HVM02**

Feeding and regenerative power supply units for modular multi-axis applications

▶ **IndraDrive control units
Cxx02**

Control units for integration in power units for individual automation solutions – from standard to high-end applications

▶ **IndraDrive M
HMD01**

Double-axis inverter for the modular realization of multi-axis applications

▶ **IndraDrive ML
HMD05**

Universally usable as a supply unit or as a single-axis inverter for large power outputs

▶ **IndraDrive Software
MPx and PSB**

The MPx drive software contains all the necessary automation functions for individual applications.

Compact converters

IndraDrive Cs

HCS01



The IndraDrive Cs compact inverters (HCS01) cover the power range in the lower kW range. They combine power and control units in a single unit and offer Ethernet-based communication, multi-encoder interfaces and integrated safety technology. The control unit functions are listed starting on page 264.

- ▶ **Power range: 0.15 ... 14 kW**
- ▶ **Maximum currents: 3.3 ... 54 A**
- ▶ **Direct power supply: 110 ... 500 V**
- ▶ **High overload capacity**
- ▶ **Compact design for single-axis applications**

Type code	
HCS01.1E-W0018-A-02-E-S3-EC-NN-NN-NN-FW	
<p>Maximum current E.g. 0018 = 18 A</p> <p>Degree of protection A = IP20</p> <p>Power supply voltage 02 = 3 x AC 110...230 V 03 = 3 x AC 200...500 V</p> <p>Control unit version E-S3 = ECONOMY with Sercos III, EtherCAT B-ET = BASIC with Multi-Ethernet (Sercos III, PROFINET IO, EtherNet/IP, EtherCAT) A-CC = ADVANCED with Sercos master (cross communication) A-ET = ADVANCED with Multi-Ethernet (Sercos III, PROFINET IO, EtherNet/IP, EtherCAT)</p> <p>Encoder EC = Multi-encoder interface</p>	<p>Drive software FW = With Standard operating panel, drive software must be ordered separately AW = With Advanced operating panel, drive Software must be ordered separately</p> <p>Safety technology NN = Without L3 = Safe Torque Off (STO) L4 = Safe Torque Off (STO) + Safe Brake Control (SBC) S4 = Safe Motion S5 = Safe Motion SB = Safe Motion Bus</p> <p>Option NN = without CN = CANopen EC = Multi-encoder interface EM = Encoder emulation EP = Engineering port ET = MultiEthernet PB = PROFIBUS DA = I/O extension digital/analog</p>

Available options and technical specifications: see product documentation (project planning instructions in the media directory: www.boschrexroth.com/mediadirectory)

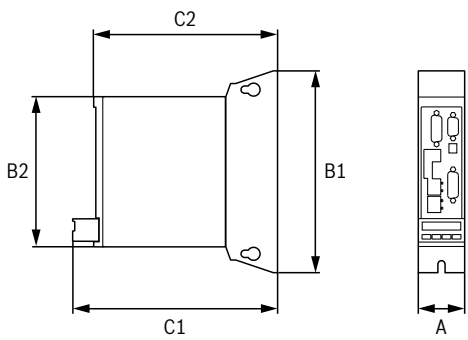

Dimensions

Type		HCS01.1E-W0003-A-02	HCS01.1E-W0006-A-02	HCS01.1E-W0009-A-02	HCS01.1E-W0013-A-02	HCS01.1E-W0018-A-02	HCS01.1E-W0005-A-03	HCS01.1E-W0008-A-03	HCS01.1E-W0018-A-03	HCS01.1E-W0028-A-03	HCS01.1E-W0054-A-03
A	mm	50	50	50	50	70	50	50	70	70	130
B1	mm	215	215	215	215	268	215	215	268	268	268
B2	mm	160	160	160	160	213	160	160	213	213	213
C1	mm	220	220	220	220	220	220	220	220	220	220
C2	mm	196	196	196	196	196	196	196	196	196	196
Mass	kg	0.72	0.72	0.72	0.72	1.70	0.72	0.72	1.70	1.70	4.22

HCS01

■ For more information, please visit: www.boschrexroth.com/cat-hcs01

Technical specifications							
Type		HCS01.1E-W0003-A-02	HCS01.1E-W0006-A-02	HCS01.1E-W0009-A-02	HCS01.1E-W0013-A-02	HCS01.1E-W0018-A-02	
Degree of protection – overall		IP20	IP20	IP20	IP20	IP20	
Degree of contamination		2	2	2	2	2	
Type of cooling		Unventilated			Forced ventilation		
Power data							
Continuous current	A	1.1	2.1	3	4.4	7.6	
Maximum current	A	3.3	6	9	13	18	
Power supply voltage	1 AC ¹⁾	V	110 ... 230	110 ... 230	110 ... 230	110 ... 230	110 ... 230
	3 AC	V	110 ... 230	110 ... 230	110 ... 230	110 ... 230	110 ... 230
Tolerance	%	±10	±10	±10	±10	±10	
Mains frequency	Hz	50 ... 60	50 ... 60	50 ... 60	50 ... 60	50 ... 60	
Frequency tolerance	Hz	±2	±2	±2	±2	±2	
Power supply continuous current	A	0.6	1.2	2.3	4.5	9.6	
DC bus							
Continuous power with choke	kW	–	–	–	–	–	
Max. power with choke	kW	–	–	–	–	–	
Continuous power without choke	kW	0.15	0.25	0.46	0.8	1.8	
Max. power without choke	kW	0.45	0.75	1.38	2.4	4.8	
Power depending on the supply voltage	U _{LN} < 400 V		1 % power reduction per 4 V				
	U _{LN} > 400 V		No power increase				
Switching frequency/max. output frequency	4 kHz	Hz	0 ... 400	0 ... 400	0 ... 400	0 ... 400	0 ... 400
	8 kHz	Hz	0 ... 800	0 ... 800	0 ... 800	0 ... 800	0 ... 800
	12 kHz	Hz	0 ... 1 200	0 ... 1 200	0 ... 1 200	0 ... 1 200	0 ... 1 200
	16 kHz	Hz	0 ... 1 600	0 ... 1 600	0 ... 1 600	0 ... 1 600	0 ... 1 600
Output voltage	3 AC	V	0 ... 230	0 ... 230	0 ... 230	0 ... 230	0 ... 230
DC bus capacity	mF	0.44	0.44	0.78	0.78	1.2	
DC bus voltage U _{DC}		Power supply voltage x 1.41 V DC					
Brake chopper/resistor							
Braking energy consumption	kWs	0.4	0.4	0.4	0.4	3	
Permanent braking power	kW	0.02	0.02	0.03	0.03	0.15	
Maximum braking power	kW	1.68	1.68	1.68	1.68	2.24	
Control voltage							
External control voltage	V	24 ±5 %	24 ±5 %	24 ±5 %	24 ±5 %	24 ±5 %	
Power consumption without control unit and motor brake	W	27	27	28	28	34	

¹⁾ Single-phase operation possible, derating for HCS01.1E-W0013-A-02 and -W0018-A-02

Technical specifications							
Type			HCS01.1E-W0005-A-03	HCS01.1E-W0008-A-03	HCS01.1E-W0018-A-03	HCS01.1E-W0028-A-03	HCS01.1E-W0054-A-03
Degree of protection – overall			IP20	IP20	IP20	IP20	IP20
Degree of contamination			2	2	2	2	2
Type of cooling			Forced ventilation				
Power data							
Continuous current	A		1.8	2.7	7	11.5	21
Maximum current	A		5	8	18	28	54
Power supply voltage	1 AC ¹⁾	V	–	–	–	–	–
	3 AC	V	200 ... 500	200 ... 500	200 ... 500	200 ... 500	200 ... 500
Tolerance	%		±10	±10	±10	±10	±10
Mains frequency	Hz		50 ... 60	50 ... 60	50 ... 60	50 ... 60	50 ... 60
Frequency tolerance	Hz		±2	±2	±2	±2	±2
Power supply continuous current	A		1.5	2.5	5	8	25
DC bus							
Continuous power with choke	kW		–	–	–	4	14
Max. power with choke	kW		–	–	–	9.7	19
Continuous power without choke	kW		0.46	0.86	1.7	2.6	9
Max. power without choke	kW		1.38	2.58	5.1	6.2	14
Power depending on the supply voltage	U _{LN} < 400 V		1 % power reduction per 4 V				
	U _{LN} > 400 V		No power increase				
Switching frequency/max. output frequency	4 kHz	Hz	0 ... 400	0 ... 400	0 ... 400	0 ... 400	0 ... 400
	8 kHz	Hz	0 ... 800	0 ... 800	0 ... 800	0 ... 800	0 ... 800
	12 kHz	Hz	0 ... 1 200	0 ... 1 200	0 ... 1 200	0 ... 1 200	0 ... 1 200
	16 kHz	Hz	0 ... 1 600	0 ... 1 600	0 ... 1 600	0 ... 1 600	0 ... 1 600
Output voltage	3 AC	V	0 ... 500	0 ... 500	0 ... 500	0 ... 500	0 ... 500
DC bus capacity	mF		0.11	0.11	0.39	0.39	0.78
DC bus voltage U _{DC}			Power supply voltage x 1.41 V DC				
Brake chopper/resistor							
Braking energy consumption	kWs		0.8	0.8	2.25	3	13
Permanent braking power	kW		0.02	0.03	0.05	0.15	0.5
Maximum braking power	kW		4	4	7.2	10.6	25.8
Control voltage							
External control voltage	V		24 ±5 %	24 ±5 %	24 ±5 %	24 ±5 %	24 ±5 %
Power consumption without control unit and motor brake	W		27	28	34	34	45

¹⁾ Single-phase operation possible, derating for HCS01.1E-W0013-A-02 and -W0018-A-02

Single-axis converters

IndraDrive C

HCS02



The single-axis inverters IndraDrive C (HCS02) cover the power range in the medium kW range. They have a mounting slot for a single-axis control unit which has various interfaces for connection to the automation environment, for encoder systems, safety technology and other digital and analog signals, etc.

- ▶ **Energy direction: feed-in**
- ▶ **Power range: 1.5 ... 11 kW**
- ▶ **Maximum currents: 12 ... 70 A**
- ▶ **Direct power supply: 200 ... 500 V**
- ▶ **2.5x overload capacity**
- ▶ **Compact design for single-axis applications**

Type code

HCS02.1E-W0012-A-03-NNNN

Maximum current

E.g. 0012 = 12 A

Other versions

NNNN = None
LNNN = Temperature-controlled fan control
NNNV = DC 24 V voltage supply from the DC bus and external

Available options and technical specifications: see product documentation (project planning instructions in the media directory: www.boschrexroth.com/mediadirectory)

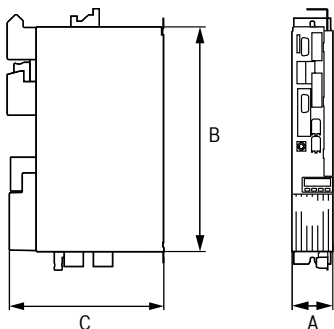

Dimensions					
Type		HCS02.1E-W0012	HCS02.1E-W0028	HCS02.1E-W0054	HCS02.1E-W0070
A	mm	65	65	105	105
B	mm	290	352	352	352
C	mm	251.5	251.5	251.5	251.5
Mass	kg	2.9	3.8	6.7	6.8

■ For more information, please visit: www.boschrexroth.com/cat-hcs02

Technical specifications						
Type			HCS02.1E-W0012	HCS02.1E-W0028	HCS02.1E-W0054	HCS02.1E-W0070
Degree of protection – overall			IP20	IP20	IP20	IP20
EMC			EN 61800-3	EN 61800-3	EN 61800-3	EN 61800-3
Type of cooling			Forced ventilation			
Power data						
Continuous current	A		4.5	12	20.6	28
Maximum current	A		11.5	28.3	54	70.8
Motor rating, typical	kW		1.5	4	7.5	11
Power supply voltage	1 AC	V	200 ... 250	200 ... 250	200 ... 250	200 ... 250
	3 AC	V	200 ... 500	200 ... 500	200 ... 500	200 ... 500
Tolerance	%		±10	±10	±10	±10
Mains frequency	Hz		50 ... 60	50 ... 60	50 ... 60	50 ... 60
Frequency tolerance	Hz		±2	±2	±2	±2
Power supply continuous current	A		6	13	20	30
Network contactor			External			
DC bus						
Continuous power with choke	kW		2.1	5.1	10	14
Max. power with choke	kW		5	10	16	19
Continuous power without choke	kW		2.1	5.1	7	9
Max. power without choke	kW		5	8	12	14
Power depending on the supply voltage	$U_{LN} < 400\text{ V}$		1 % power reduction per 4 V			
	$U_{LN} > 400\text{ V}$		1 % power increase per 5 V			
Switching frequency/max. output frequency	4 kHz	Hz	0 ... 400	0 ... 400	0 ... 400	0 ... 400
	8 kHz	Hz	0 ... 800	0 ... 800	0 ... 800	0 ... 800
	12 kHz	Hz	0 ... 1 200	0 ... 1 200	0 ... 1 200	0 ... 1 200
	16 kHz	Hz	0 ... 1 600	0 ... 1 600	0 ... 1 600	0 ... 1 600
Output voltage	3 AC	V	$\sim U_{DC} \times 0.71$	$\sim U_{DC} \times 0.71$	$\sim U_{DC} \times 0.71$	$\sim U_{DC} \times 0.71$
DC bus capacity	mF		0.135	0.27	0.54	0.675
DC bus voltage U_{DC}			Power supply voltage x 1.41 V DC			
Combination capability of converters/inverters			No	Yes	Yes	Yes
Brake chopper/resistor						
Braking resistor			Internal		Internal/external	
Brake chopper			Internal		Internal	
Braking energy consumption	kWs		1	5	9	13
Permanent braking power	kW		0.05	0.15	0.35/3.8	0.5/5.5
Maximum braking power	kW		4	10	18	25
Control voltage						
Internal control voltage	V DC		24 (not for supplying the motor holding brake)			
External control voltage	V DC		24 ±20 % (24 ±5 %) when supplying motor holding brake			
Power consumption without control unit and motor brake	W		12	14	23	23

Single-axis converters

IndraDrive C

HCS03



The single-axis IndraDrive C (HCS03) inverters have a mounting slot for a single-axis control unit that has various interfaces for connection to the automation environment, for encoder systems, safety technology and other digital and analog signals, thus covering the power range in the upper kW range.

- ▶ **Energy direction: feed-in**
- ▶ **Power range: 22 ... 110 kW**
- ▶ **Maximum currents: 70 ... 350 A**
- ▶ **Direct power supply: 400 ... 500 V**
- ▶ **1.5x overload capacity**
- ▶ **Compact design for single-axis applications**

Type code	
HCS03.1E-W0070-A-05-NNNV	

Maximum current

E.g. 0070 = 70 A

Other versions

- NNNN** = None
- NNNV** = DC 24 V voltage supply from the DC bus and external
- NNBN** = Brake transistor integrated, 24 V DC external
- NNBV** = Brake transistor integrated, 24 V DC voltage supply from DC bus and external
- LNBN** = Temperature-dependent fan control, Braking transistor integrated, DC 24 V external
- LNBV** = Temperature-dependent fan control, braking transistor integrated, DC 24 V voltage supply from DC bus and external

Available options and technical specifications: see product documentation (project planning instructions in the media directory: www.boschrexroth.com/mediadirectory)

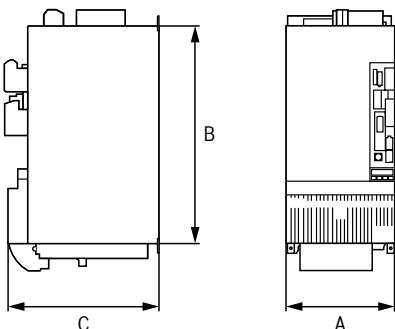

Dimensions							
Type		HCS03.1E-W0070	HCS03.1E-W0100	HCS03.1E-W0150	HCS03.1E-W0210	HCS03.1E-W0280	HCS03.1E-W0350
A	mm	125	225	225	350	350	350
B	mm	440	440	440	440	440	440
C	mm	315	315	315	315	309	309
Mass	kg	13.0	20.0	20.0	32.5	36.5	36.5

■ For more information, please visit: www.boschrexroth.com/cat-hcs03

Technical specifications							
Type		HCS03.1E-W0070	HCS03.1E-W0100	HCS03.1E-W0150	HCS03.1E-W0210	HCS03.1E-W0280	HCS03.1E-W0350
Degree of protection – overall		IP20	IP20	IP20	IP20	IP20	IP20
EMC		EN 61800-3	EN 61800-3	EN 61800-3	EN 61800-3	EN 61800-3	EN 61800-3
Type of cooling		Forced ventilation					
Power data							
Continuous current	A	45	73	95	145	165	200
Maximum current	A	70	100	150	210	280	350
Motor rating, typical	kW	22	37	45	75	90	110
Power supply voltage	3 AC	V	400 ... 500	400 ... 500	400 ... 500	400 ... 500	400 ... 500
Tolerance	%	+10 -15	+10 -15	+10 -15	+10 -15	+10 -15	+10 -15
Mains frequency	Hz	50 ... 60	50 ... 60	50 ... 60	50 ... 60	50 ... 60	50 ... 60
Frequency tolerance	Hz	±2	±2	±2	±2	±2	±2
Power supply continuous current	A	50	80	106	146	176	201
Network contactor		External					
DC bus							
Continuous power with choke	kW	25	43	56	85	100	120
Max. power with choke	kW	40	59	89	124	170	210
Continuous power without choke	kW	13	24	34	47	83	100
Max. power without choke	kW	20	33	54	68	146	175
Power depending on the supply voltage	$U_{LN} < 400\text{ V}$	1 % power reduction per 4 V					
	$U_{LN} > 400\text{ V}$	1 % power increase per 5 V					
Switching frequency/max. output frequency	4 kHz	Hz	0 ... 400	0 ... 400	0 ... 400	0 ... 400	0 ... 400
	8 kHz	Hz	0 ... 800	0 ... 800	0 ... 800	0 ... 800	0 ... 800
	12 kHz	Hz	0 ... 1 200	0 ... 1 200	0 ... 1 200	0 ... 1 200	–
	16 kHz	Hz	0 ... 1 600	0 ... 1 600	0 ... 1 600	0 ... 1 600	–
Output voltage	3 AC	V	$\sim U_{DC} \times 0.71$	$\sim U_{DC} \times 0.71$	$\sim U_{DC} \times 0.71$	$\sim U_{DC} \times 0.71$	$\sim U_{DC} \times 0.71$
DC bus capacity	mF	0.94	1.44	1.88	4.7	6.8	6.8
DC bus voltage U_{DC}		Power supply voltage x 1.41 V DC					
Combination capability of converters/inverters		Yes	Yes	Yes	Yes	Yes	Yes
Brake chopper/resistor							
Braking resistor		External					
Brake chopper		Internal					
Maximum braking power	kW	34	46	83	117	117	117
Permanent braking power	kW	10	14.5	24	36	36	36
Control voltage							
Internal control voltage	V DC	24 (not for supplying the motor holding brake)					
External control voltage	V DC	24 ±20 % (24 ±5%) when supplying motor holding brake					
Power consumption without control unit and motor brake	W	22.5	25	25	30	30	30

Multi-axis converters

IndraDrive C

HCT02/HCQ02



The multi-axis converters IndraDrive HCT (3 axes) and HCQ (4 axes) are compact drive control units and serve as basic hardware for the CNC systems MTX micro. They consist of a basic device with integrated control CPU, on-board inputs/outputs, optional slots for additional inputs/outputs as well as interfaces for the connection of HMI devices and to an Ethernet network for project planning.

- ▶ **Energy direction: feed-in**
- ▶ **Power: 25 kW**
- ▶ **Maximum currents axis-dependent: 31 A or 55 A**
- ▶ **Direct power supply: 200 ... 500 V**
- ▶ **Compact design for 3-axis or 4-axis applications with CNC system MTX micro**

Type code	
HCx02.1E-W0025-A-03-B-L8-2S-NN-NN-NN-FW	
Rated power E.g. 0025 = 25 kW	Drive software FW = Drive software must be ordered separately
Degree of protection A = IP20	Option 2 NN = Without D1 = DEA40.1
Power supply voltage 03 = 3 x AC 200...500 V	Option 1 NN = Without D1 = DEA40.1
Design of control unit and control communication B-L8 = Embedded PC	
Interfaces 1S ¹⁾ = Sercos master, 5 x encoder, 4 x probe, I/O (32DI, 16DO) 2S ²⁾ = Sercos master, 4 x encoder, 4 x probe, I/O (32DI, 16DO)	

¹⁾ Available for HCQ02

²⁾ Available for HCT02

Available options and technical specifications: see product documentation (project planning instructions in the media directory: www.boschrexroth.com/mediadirectory)

■ For more information, please visit: www.boschrexroth.com/cat-ae

Technical specifications				
Type			HCT02.1E-W0025	HCQ02.1E-W0025
Degree of protection – overall			IP20	IP20
EMC			EN 61800-3	EN 61800-3
Type of cooling			Forced ventilation	
Power data				
Continuous current ¹⁾	Axis 1	A	35	35
	Axis 2	A	–	20
	Axis 3/4	A	Per 14	Per 14
Maximum current ¹⁾	Axis 1	A	55	55
	Axis 2	A	–	50
	Axis 3/4	A	Per 31	Per 31
Power data				
Nominal power, typical			kW	25
Power supply voltage	3 AC	V	200 ... 500	200 ... 500
Tolerance			%	±10
Mains frequency			Hz	50 ... 60
Frequency tolerance			Hz	±2
Power supply continuous current			A	44
Network contactor			External	
DC bus				
Continuous power with choke			kW	25
Max. power with choke			kW	37.5
Continuous power without choke			kW	15
Max. power without choke			kW	22.5
Power depending on the supply voltage	$U_{LN} < 400\text{ V}$	1 % power reduction per 4 V		
	$U_{LN} > 400\text{ V}$	1 % power increase per 5 V		
Switching frequency/max. output frequency	4 kHz	Hz	0 ... 400	0 ... 400
	8 kHz	Hz	0 ... 800	0 ... 800
Inverter output voltage	3 AC	V	0 ... 500	0 ... 500
DC bus capacity			mF	1.18
DC bus voltage U_{DC}			Power supply voltage x 1.41 V DC	
Brake chopper/resistor				
Braking resistor			External	
Brake chopper			Internal	
Braking energy consumption			kWs	100
Permanent braking power			kW	5
Control voltage				
Internal control voltage			V	24

¹⁾ at output frequency 4 kHz

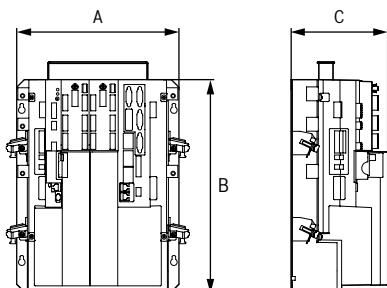

Dimensions				
Type			HCT02.1E-W0025	HCQ02.1E-W0025
A	mm		320	320
B	mm		420	420
C	mm		191	191
Mass	kg		11.7	11.7

Supply unit

IndraDrive M

HMV01



The HMV01 supply units generate a DC bus voltage from the supply voltage. They are available in both feed-in and energy-efficient feed-in/regenerative variants. Feed-in/feed-back variants can feed regenerative energy back into the supply network and also regulate the DC bus voltage at a constant level independent of the mains voltage. Depending on the size, components such as network contactor, braking transistor or braking resistor are already integrated in the supply units. Air cooling is the only type of cooling available.

- ▶ **Energy direction feed-in or feed-in/regenerating**
- ▶ **Power range: 18 ... 120 kW**
- ▶ **Power supply voltage: 380 ... 480 V**
- ▶ **Degree of protection: IP20**

Type code	
HMV01.1E-W0030-A-07-NNNN	
EMC area E = Feed-in R = Regenerative	Power supply voltage NNNN = None FNN2 = Smart Energy Mode
Rated power E.g. 0030 = 30 kW	Rated DC bus voltage 07 = DC 750 V

Available options and technical specifications: see product documentation (project planning instructions in the media directory: www.boschrexroth.com/mediadirectory)

■ For more information, please visit: www.boschrexroth.com/cat-hmv01

Technical specifications					
Type			HMV01.1E-W0030	HMV01.1E-W0075	HMV01.1E-W0120
Degree of protection – overall			IP20	IP20	IP20
EMC			EN 61800-3	EN 61800-3	EN 61800-3
Type of cooling			Forced ventilation		
Power data					
Power supply voltage	3 AC	V	380 ... 480	380 ... 480	380 ... 480
Tolerance		%	±10	±10	±10
Mains frequency		Hz	50 ... 60	50 ... 60	50 ... 60
Frequency tolerance		Hz	±2	±2	±2
Power supply continuous current		A	51	128	204
DC bus					
Continuous power with choke		kW	30	75	120
Max. power with choke		kW	45	112.5	180
Continuous power without choke		kW	18	45	72
Max. power without choke		kW	45	112.5	180
Power depending on the supply voltage		$U_{LN} < 400\text{ V}$	1 % power reduction per 4 V		
		$U_{LN} > 400\text{ V}$	1 % power increase per 5 V		
DC bus capacity		mF	1.41	3.76	5.64
DC bus voltage U_{DC}		V DC	Power supply voltage x 1.41 V DC		
Brake chopper/resistor					
Braking resistor			Internal		
Braking energy consumption		kWs	100	250	500
Permanent braking power		kW	1.5	2	2.5
Maximum braking power		kW	36	90	130
Control voltage					
External control voltage		V	24 ±5 %	24 ±5 %	24 ±5 %
Power consumption without control unit and motor brake		W	25	30	55

HMV01

■ For more information, please visit: www.boschrexroth.com/cat-hmv01

Technical specifications					
Type		HMV01.1R-W0018	HMV01.1R-W0045	HMV01.1R-W0065	HMV01.1R-W0120
Degree of protection – overall		IP20	IP20	IP20	IP20
EMC		EN 61800-3	EN 61800-3	EN 61800-3	EN 61800-3
Type of cooling		Forced ventilation			
Power data					
Power supply voltage 3 AC	V	380 ... 480	380 ... 480	380 ... 480	380 ... 480
Tolerance	%	±10	±10	±10	±10
Mains frequency	Hz	50 ... 60	50 ... 60	50 ... 60	50 ... 60
Frequency tolerance	Hz	±2	±2	±2	±2
Power supply continuous current	A	26	65	94	181
DC bus					
Continuous power with choke	kW	18	45	65	120
Max. power with choke	kW	45	112	162	180
Continuous power without choke	kW	–	–	–	–
Max. power without choke	kW	–	–	–	–
Power depending on the supply voltage	$U_{LN} < 400 \text{ V}$	1 % power reduction per 4 V			
	$U_{LN} > 400 \text{ V}$	No power increase			
DC bus capacity	mF	0.705	1.88	2.82	4.95
DC bus voltage U_{DC}	V DC	750 V, regulated			
Brake chopper/resistor					
Braking resistor		Internal			External
Braking energy consumption	kWs	80	100	150	–
Permanent braking power	kW	0.4	0.4	0.4	–
Maximum braking power	kW	36	90	130	–
Control voltage					
External control voltage	V	24 ±5 %	24 ±5 %	24 ±5 %	24 ±5 %
Power consumption without control unit and motor brake	W	31	41	108	224 ¹⁾

¹⁾ Auxiliary fan included HAB

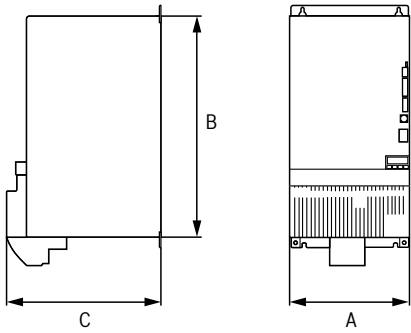

Dimensions		HMV01.1 E-W0030	HMV01.1 E-W0075	HMV01.1 E-W0120	HMV01.1 R-W0018	HMV01.1 R-W0045	HMV01.1 R-W0065	HMV01.1 R-W0120
A	mm	150	250	350	175	250	350	350
B	mm	440	440	440	440	440	440	440
C	mm	309	309	309	309	309	309	309
Mass	kg	13.5	22.0	32.0	13.5	20.0	31.0	34.5

Single-axis inverter

IndraDrive M

HMS01



The single-axis inverters HMS01 are supplied with DC voltage and generate a regulated AC output voltage with variable amplitude and frequency for the operation of a motor. They have a mounting slot for a single-axis control unit which has various interfaces for connection to the automation environment, for encoder systems, safety technology and other digital and analog signals, etc. For multi-axis applications, the inverters are supplied with power from the DC bus of supply units HMV01 or HMU05. Supply from the DC bus of an HCS converter is also possible for smaller axis packages and with the corresponding power reserve of the HCS.

- ▶ **Power range: 5.5 ... 132 kW**
- ▶ **Continuous currents: 12.1 ... 250 A**
- ▶ **Maximum currents: 12 ... 350 A**
- ▶ **DC supply voltage: 540 V ... 750 V**
- ▶ **Degree of protection: IP20**

Type code

HMS01.1N-W0020-A-07-NNNN

Maximum current

E.g. 0020 = 20 A

Rated DC bus voltage

07 = DC 750 V

Available options and technical specifications: see product documentation (project planning instructions in the media directory: www.boschrexroth.com/mediadirectory)

■ For more information, please visit: www.boschrexroth.com/cat-hms01

Technical specifications							
Type			HMS01.1N-W0020	HMS01.1N-W0036	HMS01.1N-W0054	HMS01.1N-W0070	HMS01.1N-W0110
Degree of protection – overall			IP20	IP20	IP20	IP20	IP20
EMC			EN 61800-3	EN 61800-3	EN 61800-3	EN 61800-3	EN 61800-3
Type of cooling			Forced ventilation				
Motor inverter							
Continuous current	A		12.1	21.3	35	42.4	68.5
Maximum current	A		20	36	54	70.7	110
Motor rating, typical	kW		5.5	11	18.5	22	37
Switching frequency/ max. output frequency	4 kHz	Hz	0 ... 400	0 ... 400	0 ... 400	0 ... 400	0 ... 400
	8 kHz	Hz	0 ... 800	0 ... 800	0 ... 800	0 ... 800	0 ... 800
	12 kHz	Hz	0 ... 1 200	0 ... 1 200	0 ... 1 200	0 ... 1 200	0 ... 1 200
	16 kHz	Hz	0 ... 1 600	0 ... 1 600	0 ... 1 600	0 ... 1 600	0 ... 1 600
Output voltage	3 AC	V	0 ... $U_{DC} \times 0.71$	0 ... $U_{DC} \times 0.71$	0 ... $U_{DC} \times 0.71$	0 ... $U_{DC} \times 0.71$	0 ... $U_{DC} \times 0.71$
DC bus							
DC bus capacity	mF		–	–	–	–	–
DC bus voltage U_{DC}	V DC		254 ... 750	254 ... 750	254 ... 750	254 ... 750	254 ... 750
Control voltage							
Power consumption without control unit and motor brake	W		10	15	10	16	34

HMS01

■ For more information, please visit: www.boschrexroth.com/cat-hms01

Technical specifications						
Type			HMS01.1N-W0150	HMS01.1N-W0210	HMS01.1N-W0300	HMS01.1N-W0350
Degree of protection – overall			IP20	IP20	IP20	IP20
EMC			EN 61800-3	EN 61800-3	EN 61800-3	EN 61800-3
Type of cooling			Forced ventilation			
Motor inverter						
Continuous current	A		99.7	150.7	150	250
Maximum current	A		150	210	300	350
Motor rating, typical	kW		55	75	75	132
Switching frequency/ max. output frequency	4 kHz	Hz	0 ... 400	0 ... 400	0 ... 400	0 ... 400
	8 kHz	Hz	0 ... 800	0 ... 800	0 ... 800	0 ... 800
	12 kHz	Hz	0 ... 1 200	0 ... 1 200	0 ... 1 200	0 ... 1 200
	16 kHz	Hz	0 ... 1 600	0 ... 1 600	0 ... 1 600	–
Output voltage	3 AC	V	0 ... $U_{DC} \times 0.71$	0 ... $U_{DC} \times 0.71$	0 ... $U_{DC} \times 0.71$	0 ... $U_{DC} \times 0.71$
DC bus						
DC bus capacity	mF		–	–	–	4.9
DC bus voltage U_{DC}	V DC		254 ... 750	254 ... 750	254 ... 750	254 ... 750
Control voltage						
Power consumption without control unit and motor brake	W		23	75	100	218

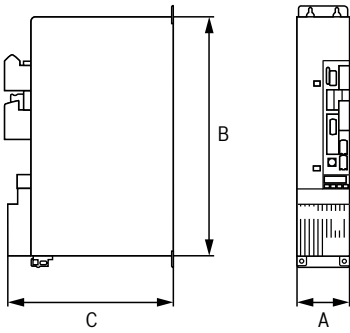

Dimensions		HMS01.1N-W0020	HMS01.1N-W0036	HMS01.1N-W0054	HMS01.1N-W0070	HMS01.1N-W0110	HMS01.1N-W0150	HMS01.1N-W0210	HMS01.1N-W0300	HMS01.1N-W0350
A	mm	50.0	50.0	75.0	100.0	125.0	150.0	200.0	200.0	349.5
B	mm	440.0	440.0	440.0	440.0	440.0	440.0	440.0	440.0	440.0
C	mm	309.0	309.0	309.0	309.0	309.0	309.0	309.0	309.0	309.0
Mass	kg	5.27	5.27	6.68	7.94	11.06	12.74	16.44	16.44	31.70

Double-axis inverter

IndraDrive M

HMD01



The HMD01 double-axis inverters are supplied with DC voltage and generate two independently controlled AC output voltages with variable amplitude and frequency for the operation of two motors. They have a mounting slot for a double axis control unit, which has various interfaces for connection to the automation environment, for encoder systems, safety technology and other digital and analog signals, etc. For multi-axis applications, the inverters are supplied with power from the DC bus of supply units HMV01 or HMU05. Supply from the DC bus of an HCS converter is also possible for smaller axis packages and with the corresponding power reserve of the HCS.

- ▶ **Power range: 3 ... 7.5 kW**
- ▶ **Continuous currents: 7 ... 20 A**
- ▶ **Maximum currents: 12 ... 36 A**
- ▶ **DC supply voltage: 540 ... 750 V**
- ▶ **Degree of protection: IP20**

Type code

HMD01.1N-W0020-A-07-NNNN

Maximum current

E.g. 0020 = 20 A

Rated DC bus voltage

07 = DC 750 V

Available options and technical specifications: see product documentation (project planning instructions in the media directory: www.boschrexroth.com/mediadirectory)

■ For more information, please visit: www.boschrexroth.com/cat-hmd01

Technical specifications				
Type	HMD01.1N-W0012		HMD01.1N-W0020	HMD01.1N-W0036
Degree of protection – overall	IP20		IP20	IP20
EMC	EN 61800-3		EN 61800-3	EN 61800-3
Type of cooling	Forced ventilation			
Motor inverter				
Continuous current	A	6.9	10	20
Maximum current	A	12	20	36
Motor rating, typical	kW	3	4	7.5
Switching frequency/ max. output frequency	4 kHz	Hz	0 ... 400	0 ... 400
	8 kHz	HZ	0 ... 800	0 ... 800
Output voltage	3 AC	V	0 ... $U_{DC} \times 0.71$	0 ... $U_{DC} \times 0.71$
DC bus				
DC bus voltage U_{DC}	V DC	254 ... 750	254 ... 750	254 ... 750
Control voltage				
Power consumption without control unit and motor brake	W	17	17	11

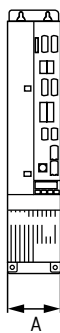
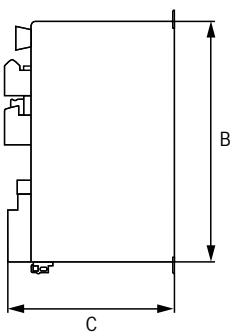

Dimensions				
Type	HMD01.1N-W0012		HMD01.1N-W0020	HMD01.1N-W0036
A	mm	50	50	75
B	mm	440	440	440
C	mm	309	309	309
Mass	kg	5.5	5.6	7.5

Supply unit

IndraDrive M

HMV02



The HMV02 supply unit generates a DC bus voltage from the supply voltage. It is available as an energy-efficient feed-in/regeneration variant. This means that regenerative energy can also be fed back into the supply network and, in addition, the DC bus voltage can be regulated at a constant level independent of the mains voltage. The network contactor, braking transistor or braking resistor are integrated. Air cooling is the only type of cooling available.

- ▶ **Energy direction feed-in/regeneration**
- ▶ **Power: 15 kW**
- ▶ **Power supply voltage: 380 ... 480 V**
- ▶ **Degree of protection: IP20**

Type code	
HMV02.1R-W0015-A-07-NNNN	
Power supply unit R = Regenerative	Power supply voltage NNNN = None FNN2 = Smart Energy Mode
Rated power 0015 = 15 kW	Rated DC bus voltage 07 = DC 750 V

Available options and technical specifications: see product documentation (project planning instructions in the media directory: www.boschrexroth.com/mediadirectory)

■ For more information, please visit: www.boschrexroth.com/cat-hmv02

Technical specifications			
Type	HMV02.1R-W0015		
Degree of protection – overall	IP20		
EMC	EN 61800-3		
Type of cooling	Forced ventilation		
Power data			
Power supply voltage	3 AC	V	380 ... 480
Tolerance		%	±10
Mains frequency		Hz	50 ... 60
Frequency tolerance		Hz	±2
Power supply continuous current		A	23
DC bus			
Continuous power with choke		kW	15
Max. power with choke		kW	30
Power depending on the supply voltage	$U_{LN} < 400 \text{ V}$		1 % power reduction per 4 V
	$U_{LN} > 400 \text{ V}$		No power increase
Output voltage		V DC	750, regulated
DC bus capacity		mF	0.705
Brake chopper/resistor			
Braking energy consumption		kWs	40
Permanent braking power		kW	0.3
Maximum braking power		kW	33
Control voltage			
External control voltage		V	24 ±5 %
Power consumption without control unit and motor brake		W	27

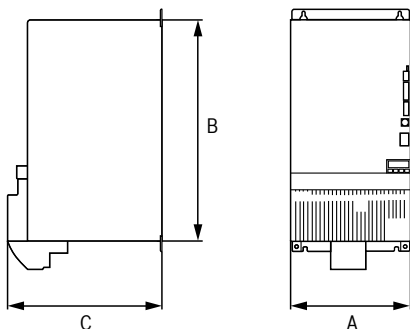

Dimensions		
Type	HMV02.1R-W0015	
A	mm	150.0
B	mm	352.0
C	mm	251.5
Mass	kg	9.5

Single-axis inverter

IndraDrive M

HMS02



The single-axis inverters HMS02 are supplied with DC voltage and generate a regulated AC output voltage with variable amplitude and frequency for the operation of a motor. The integrated control unit slot that has various interfaces for connecting to the automation environment, for encoder systems, safety technology, and additional digital and analog signals, etc.

Multi-axis applications are supplied from the DC bus of the HMV02 and for smaller axis packages, as well as with the corresponding power reserve of the HCS02, supply from the DC bus of an HCS converter is also possible.

- ▶ **Power range: 5.5 ... 11 kW**
- ▶ **Continuous currents: 13.8 ... 25 A**
- ▶ **Maximum currents: 28 ... 54 A**
- ▶ **DC supply voltage: 540 ... 750 V**
- ▶ **Degree of protection: IP20**

Type code

HMS02.1N-W0028-A-07-NNNN

Maximum current

E.g. 0028 = 28 A

Rated DC bus voltage

07 = DC 750 V

Available options and technical specifications: see product documentation (project planning instructions in the media directory: www.boschrexroth.com/mediadirectory)

■ For more information, please visit: www.boschrexroth.com/cat-hms02

Technical specifications				
Type			HMS02.1N-W0028	HMS02.1N-W0054
Degree of protection – overall			IP20	IP20
EMC			EN 61800-3	EN 61800-3
Type of cooling			Forced ventilation	
Motor inverter				
Continuous current	A		13.8	25
Maximum current	A		28.3	54
Motor rating, typical	kW		–	–
Switching frequency/max. output frequency	4 kHz	Hz	0 ... 400	0 ... 400
	8 kHz	Hz	0 ... 800	0 ... 800
	12 kHz	Hz	–	0 ... 1 200
	16 kHz	Hz	–	0 ... 1 600
Output voltage	3 AC	V	0 ... $U_{DC} \times 0.71$	0 ... $U_{DC} \times 0.71$
DC bus				
DC bus capacity	mF		0.14	0.27
DC bus voltage U_{DC}	V DC		254 ... 750	254 ... 750
Control voltage				
Power consumption without control unit and motor brake	W		13	17

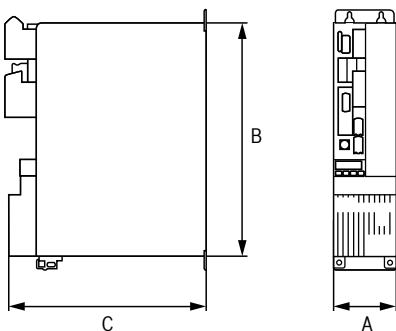

Dimensions				
Type			HMS02.1N-W0028	HMS02.1N-W0054
A	mm		49.5	74.5
B	mm		352.0	352.0
C	mm		251.5	251.5
Mass	kg		3.5	5.0

Universal inverters

IndraDrive ML

HMU05



Universal inverters HMU05 can be used both as single-axis inverters for operating a motor and as energy-efficient feed-in/regenerative power supply units. They have a mounting slot for a control unit which has various interfaces for connection to the automation environment, for encoder systems, safety technology and other digital and analog signals, etc. The respective use of the HMU05 is determined by the corresponding firmware in the control unit and, if necessary, the mains connection components. Air and liquid cooling are available as types of cooling.

Energy-efficient, universal, intelligent

When operated as a single-axis inverter, the HMU05 is powered by direct current and uses it to generate a controlled AC output voltage of variable amplitude and frequency for operating a motor. The firmware in the control unit controls the single-axis inverter and offers extensive additional functions.

The inverters are powered by the DC bus from an HMU05 operated as a supply unit. When operated as feed-in/regenerative power supply units, the HMU05 generates a DC bus voltage from the supply voltage. This means that regenerative energy can also be fed back into the supply network and, in addition, the DC bus voltage can be regulated at a constant level independent of the mains voltage. The firmware in the control unit controls the supply unit and implements extensive additional functions.

- ▶ **Universally usable as supply unit or as single-axis inverter**
- ▶ **Power range: 132 kW ... 4 MW**
- ▶ **Power supply voltage: 380 ... 690 V**
- ▶ **DC bus voltage: 540 ... 1 100 V**
- ▶ **Feed-in/regeneration function (when used as supply)**
- ▶ **Type of cooling: Air or liquid cooling**
- ▶ **Wide range of applications thanks to extensive certifications, e.g.: CE, UL, CSA for industrial applications and type approval according to DNV GL, ABS, LR for marine applications**

Optimal device topology

Reduced stocking costs due to a scaled hardware concept

- ▶ Universal inverters can be used as motor inverters or mains inverters with energy-regeneration function
- ▶ Optimally graduated power range of 132 ... 500 kW
- ▶ Parallel switching to boost the power range of the system performance up to 4 MW
- ▶ Wide voltage range of 380 ... 500 V and 525 ... 690 V
- ▶ High pulse-width modulation frequency (PWM) for optimal utilization of the motor
- ▶ Low harmonic emissions for good compatibility with the network
- ▶ Regulated DC bus voltage – independent of the mains voltage and robust against voltage fluctuations

Alternative cooling concepts

From basic dissipation of heat loss to utilization in heat-recovery systems

- ▶ Air cooling
- ▶ Air cooling with separate air duct
- ▶ Liquid cooling

Application-optimized energy-saving concepts

The optimal function for lowering consumption and reducing peak loads that takes almost every application into account

- ▶ Energy feedback into the supply grid
- ▶ Energy exchange of the drives by a DC bus
- ▶ Kinetic buffering with rotating energy storage
- ▶ Electric buffering with static energy storage
- ▶ Smart Energy Mode for soft power recovery, for example
- ▶ Regulation of reactive current to reduce the power loss in the power supply

High-performance control units with intelligent firmware

- ▶ Bespoke performance
- ▶ BASIC – simple and standard servo applications
- ▶ ADVANCED – high-end servo applications
- ▶ Multi-Ethernet and multi-encoder interface
- ▶ Interface options for fieldbus, I/O, etc.
- ▶ Firmware options as extension package

Integrated control functions

- ▶ Drive-integrated Motion Logic MLD
 - MLD-S single-axis control
 - MLD-M multi-axis control
- ▶ Application-specific, predefined technology functions
- ▶ Programming in accordance with IEC 61131-3

Certified safety technology

- ▶ Drive-integrated safety technology to protect man, machine, and work piece
- ▶ Certified according to EN ISO 13849-1 and EN 62061
- ▶ Safe Torque Off for safe interruption of applied torque
- ▶ Safe Motion for safe movements

Type code	
HMU05.1N-F 0270-0660-N-A4-D7-N1N-NNNN	
<p>Type of cooling</p> <p>F = Liquid cooling W = Air cooling</p> <p>Continuous power in the DC bus/maximum current</p> <p>E.g. 0270-0660 = 270 kW/660 A</p> <p>Power supply voltage/DC bus voltage</p> <p>A4-D7 = 3 x AC 380 ... 500 V/DC 750 V A5-11 = 3 x AC 525 ... 690 V/DC 1 100 V</p>	<p style="text-align: right;">Other version</p> <p style="text-align: right;">NNNN = None MNNN = Marine</p> <p style="text-align: center;">Single/parallel operation of universal inverters</p> <p>N1N = Single operation, unit cannot be connected in parallel</p> <p>P1B = Single operation, unit can be connected in parallel</p> <p>P11 = Parallel operation, unit as master PB1 = Parallel operation, unit as slave</p> <p>PBB = Optional stations for parallel operation are not equipped, unit can be connected in parallel</p>

Available options and technical specifications: see product documentation (project planning instructions in the media directory: www.boschrexroth.com/mediadirectory)

HMU05, air-cooled, U_{LN} 380 ... 500 V

■ For more information, please visit: www.boschrexroth.com/cat-hmu05

Technical specifications						
Type		HMU05.1N-W0140-0350-N-A4-D7	HMU05.1N-W0170-0430-N-A4-D7	HMU05.1N-W0220-0510-N-A4-D7	HMU05.1N-W0270-0660-N-A4-D7	HMU05.1N-W0340-0820-N-A4-D7-P
Degree of protection – unit/connections		IP20/IP00 (IEC529)				
EMC		EN 61800-3				
Certifications		CE: EN 61800-5-1; UL: UL 61800-5-1; CSA: C22.2 No. 14-10				
Degree of contamination		2 (EN 50178)				
Type of cooling		Air cooling				
Power loss	W	2 300	3 000	4 800	5 600	5 000
Power data as supply unit (low degree of overload capacity ¹⁾ high degree of overload capacity ²⁾)						
DC bus basic power	kW	139/120	168/144	218/173	267/216	336/270
DC bus overload capacity	kW	153/180	185/216	240/260	294/324	370/405
DC bus continuous power	kW	140	170	220	270	340
Power supply voltage U _{LN}	V	3 AC 380 ... 500 (–15 %/+10 %)				
Mains frequency	Hz	50/60 (±2 Hz)				
DC bus voltage U _{DC}	V	Regulated: variable 1.56 x U _{LN} or fixed 750 V				
Power data as motor inverter (low degree of overload capacity ¹⁾ high degree of overload capacity ²⁾)						
Typical motor rating ³⁾	kW	132/110	160/132	200/160	250/200	315/250
Base-load current	A	250/210	300/250	388/300	460/388	605/485
Overload current	A	275/315	330/275	426/421	506/582 ⁶⁾	665/727
Continuous current	A	254	306	392	470	616
Maximum current	A	357	427	515	660	825
Rated switching frequency	kHz	4	4	4	4	2
Switching frequency/ max. output frequency	2 kHz	Hz	200	200	200	200
	4 kHz	Hz	400	400	400	400
	8 kHz	Hz	800	800	800	800
Derating factor 2 to 4 kHz ⁴⁾		–	–	–	–	0.76
Derating factor 4 to 8 kHz ⁴⁾		0.63	0.58	0.52	0.48	0.48

Technical specifications						
Type		HMU05.1N-W0140-0350-N-A4-D7	HMU05.1N-W0170-0430-N-A4-D7	HMU05.1N-W0220-0510-N-A4-D7	HMU05.1N-W0270-0660-N-A4-D7	HMU05.1N-W0340-0820-N-A4-D7-P
Other data						
Parallel switching capability ⁵⁾	Yes	Yes	Yes	Yes	Yes	Yes
Derating parallel operation	0.95	0.95	0.95	0.95	0.95	0.95
DC bus capacity	mF	4.95	4.95	6.6	8.25	9.9
Network contactor	External	External	External	External	External	External
Braking transistor/resistor	External	External	External	External	External	External
Control voltage data						
External control voltage	V	DC 24 (±20 %)				
	V	DC 24 (±5 %) when supplying motor holding brake				
Power consumption (without control unit and motor brake)	W	48	48	53	46	48

¹⁾ Basic load for 540 s, 10 % overload for 60 s

²⁾ Basic load for 540 s, 50 % overload for 60 s

³⁾ 4-pin asynchronous motor, 400 V, 50 Hz

⁴⁾ With regard to continuous current

⁵⁾ Up to 4 kHz (6 kHz on request), only devices of identical power, as supply unit 7 in parallel, as motor inverter 8 in parallel

⁶⁾ Limited backlash times

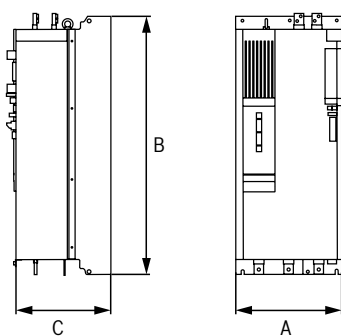

Dimensions						
Type		HMU05.1N-W0140-0350-N-A4-D7	HMU05.1N-W0170-0430-N-A4-D7	HMU05.1N-W0220-0510-N-A4-D7	HMU05.1N-W0270-0660-N-A4-D7	HMU05.1N-W0340-0820-N-A4-D7-P
A	mm	450	450	450	450	450
B	mm	1 100	1 100	1 250	1 570	1 570
C	mm	400	400	400	400	400
Mass	kg	110	110	126	172	172

HMU05, liquid-cooled, U_{LN} 380 ... 500 V

■ For more information, please visit: www.boschrexroth.com/cat-hmu05

Technical specifications								
Type		HMU05.1N-F0140-0350-N-A4-D7	HMU05.1N-F0170-0430-N-A4-D7	HMU05.1N-F0220-0510-N-A4-D7	HMU05.1N-F0270-0660-N-A4-D7	HMU05.1N-F0340-0820-N-A4-D7	HMU05.1N-F0430-1040-N-A4-D7	HMU05.1N-F0540-1300-N-A4-D7
Degree of protection – unit/connections	IP20/IP00 (IEC529)							
EMC	EN 61800-3							
Certifications	CE: EN 61800-5-1; UL: UL 61800-5-1; CSA: C22.2 No. 14-10; DNV GL; LR							
Degree of contamination	2 (EN 50178)							
Type of cooling	Liquid cooling							
Power loss in water	W	2 100	2 500	3 500	4 500	4 500	5 500	7 500
Power loss in air	W	400	500	750	1 000	1 000	1 000	1 200
Power data as supply unit (low degree of overload capacity ¹⁾ high degree of overload capacity ²⁾								
DC bus basic power	kW	122/120	168/144	218/173	267/216	336/270	426/339	535/430
DC bus overload power	kW	153/180	185/216	240/260	294/324	370/405	468/509	589/645
Continuous power in the DC bus	kW	140	170	220	270	340	430	540
Power supply voltage U _{LN}	V	3 AC 380 ... 500 (-15 %/+10 %)						
Mains frequency	Hz	50/60 (±2 Hz)						
DC bus voltage U _{DC}	V	Regulated: variable 1.56 x U _{LN} or fixed 750 V						
Power data as motor inverter (low degree of overload capacity ¹⁾ high degree of overload capacity ²⁾								
Typical motor rating ³⁾	kW	132/110	160/132	200/160	250/200	315/250	400/315	500/400
Base-load current	A	251/210	303/251	388/303	485/388	610/485	763/610	992/763
Overload current	A	276/314	333/377	427/454	533/582	671/727	839/915	1 091/1 144
Continuous current	A	254	306	392	490	616	771	1 002
Maximum current	A	357	427	515	660	825	1 037	1 297
Rated switching frequency	kHz	4	4	4	4	2	2	2
Switching frequency/ max. Output frequency	2 kHz	Hz	200	200	200	200	200	200
	4 kHz	Hz	400	400	400	400	400	400
	8 kHz	Hz	800	800	800	800	800	800
Derating factor 2 to 4 kHz ⁴⁾	–	–	–	–	–	0.89	0.81	0.77
Derating factor 4 to 8 kHz ⁴⁾	0.72	0.85	0.8	0.71	0.67	0.75	0.68	

Technical specifications								
Type		HMU05.1N-F0140-0350-N-A4-D7	HMU05.1N-F0170-0430-N-A4-D7	HMU05.1N-F0220-0510-N-A4-D7	HMU05.1N-F0270-0660-N-A4-D7	HMU05.1N-F0340-0820-N-A4-D7	HMU05.1N-F0430-1040-N-A4-D7	HMU05.1N-F0540-1300-N-A4-D7
Other data								
Parallel switching capability ⁵⁾	Yes							
Derating parallel operation	0.95	0.95	0.95	0.95	0.95	0.95	0.95	0.95
DC bus capacity	mF	4.95	4.95	6.6	8.25	9.9	13.2	16.5
Network contactor	External							
Braking transistor/resistor	External							
Control voltage data								
External control voltage	V	DC 24 (±20 %)						
	V	DC 24 (±5 %) when supplying motor holding brake						
Power consumption (without control unit and motor brake)	W	65	48	53	46	48	56	58

¹⁾ Basic load for 540 s, 10 % overload for 60 s

²⁾ Basic load for 540 s, 50 % overload for 60 s

³⁾ 4-pin asynchronous motor, 400 V, 50 Hz

⁴⁾ With regard to continuous current

⁵⁾ Up to 4 kHz (6 kHz on request), only devices of identical power, as supply unit 7 in parallel, as motor inverter 8 in parallel

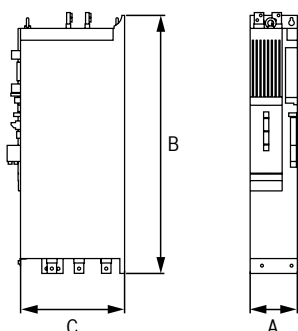

Dimensions								
Type		HMU05.1N-F0140-0350-N-A4-D7	HMU05.1N-F0170-0430-N-A4-D7	HMU05.1N-F0220-0510-N-A4-D7	HMU05.1N-F0270-0660-N-A4-D7	HMU05.1N-F0340-0820-N-A4-D7	HMU05.1N-F0430-1040-N-A4-D7	HMU05.1N-F0540-1300-N-A4-D7
A	mm	200	200	200	200	200	200	220
B	mm	805	805	909	1 013	1 091	1 299	1 507
C	mm	440	440	440	440	440	440	440
Mass	kg	51	51	58	65	70	83	103

HMU05, liquid-cooled, U_{LN} 525 ... 690 V

■ For more information, please visit: www.boschrexroth.com/cat-hmu05

Technical specifications							
Type		HMU05.1N-F0140-0210-N-A5-11	HMU05.1N-F0170-0250-N-A5-11	HMU05.1N-F0220-0300-N-A5-11	HMU05.1N-F0270-0370-N-A5-11	HMU05.1N-F0400-0600-N-A5-11	HMU05.1N-F0540-0750-N-A5-11
Degree of protection – unit/connections	IP20/IP00 (IEC529)						
EMC	EN 61800-3						
Certifications	CE: EN 61800-5-1; UL: UL 61800-5-1; CSA: C22.2 No. 14-10; DNV GL; ABS LR						
Degree of contamination	2 (EN 50178)						
Type of cooling	Liquid cooling						
Power data as supply unit (low degree of overload capacity ¹⁾ high degree of overload capacity ²⁾							
DC bus basic power	kW	139/120	153/180	218/173	267/216	396/315	535/430
DC bus overload power	kW	153/180	185/216	240/260	297/324	440/473	589/645
Continuous power in the DC bus	kW	140	170	220	270	400	535
Power supply voltage U _{LN}	V	3 AC 525 ... 690 (-15 %/+10 %)					
Mains frequency	Hz	50/60 (±2 Hz)					
DC bus voltage U _{DC}	V	Regulated: variable 1.56 x U _{LN} or fixed 1 100 V					
Power data as motor inverter (low degree of overload capacity ¹⁾ high degree of overload capacity ²⁾							
Typical motor rating ³⁾	kW	132/110	160/132	200/160	250/200	355/315	500/400
Base-load current	A	146/122	175/146	216/175	281/216	353/353	575/442
Overload current	A	160/182	193/218	238/263	309/324	388/530	633/663
Continuous current	A	147	177	227	284	379	587
Maximum current	A	207	248	298	367	600	751
Rated switching frequency	kHz	4	4	4	2	2	2
Switching frequency/ max. output frequency	2 kHz	Hz	200	200	200	200	200
	4 kHz	Hz	400	400	400	400	400
	8 kHz	Hz	800	800	800	800	800
Derating factor 2 to 4 kHz ⁴⁾		–	–	–	0.8	0.71	0.64
Derating factor 4 to 8 kHz ⁴⁾		0.68	0.56	0.44	0.44	0.52	0.33
Other data							
Parallel switching capability ⁵⁾		Yes					
Derating parallel operation		0.95					
DC bus capacity	mF	2.2	2.2	3.3	3.3	4.4	6.6
Network contactor		External					
Braking transistor/resistor		External					

Technical specifications							
Type		HMU05.1N-F0140-0210-N-A5-11	HMU05.1N-F0170-0250-N-A5-11	HMU05.1N-F0220-0300-N-A5-11	HMU05.1N-F0270-0370-N-A5-11	HMU05.1N-F0400-0600-N-A5-11	HMU05.1N-F0540-0750-N-A5-11
Control voltage data							
External control voltage	V	DC 24 (±20 %)					
	V	DC 24 (±5 %) when supplying motor holding brake					
Power consumption (without control unit and motor brake)	W	36	39	40	34	42	49

¹⁾ Basic load for 540 s, 10 % overload for 60 s

²⁾ Basic load for 540 s, 50 % overload for 60 s

³⁾ 4-pin asynchronous motor, 690 V, 50 Hz

⁴⁾ With regard to continuous current

⁵⁾ Up to 4 kHz (6 kHz on request), only devices of identical power, as supply unit 7 in parallel, as motor inverter 8 in parallel

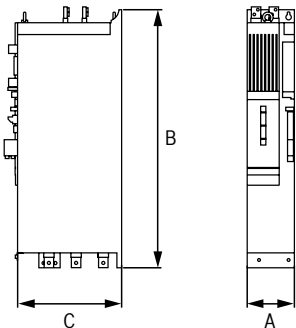

Dimensions							
Type		HMU05.1N-F0140-0210-N-A5-11	HMU05.1N-F0170-0250-N-A5-11	HMU05.1N-F0220-0300-N-A5-11	HMU05.1N-F0270-0370-N-A5-11	HMU05.1N-F0400-0600-N-A5-11	HMU05.1N-F0540-0750-N-A5-11
A	mm	200	200	200	200	200	200
B	mm	805	805	909	909	1 091	1 299
C	mm	440	440	440	440	440	440
Mass	kg	51	51	58	58	70	83

IndraDrive

Control units



The IndraDrive control units are suitable for both standard and high-end applications. They offer integrated motion logic, numerous technology functions, certified safety technology and standardized interfaces. The control units differ in their performance, function and configuration and can be combined with different firmware versions and operating panels.

- ▶ **Individual solutions for standard to high-end applications**
- ▶ **Open interfaces for international use**
- ▶ **Integrated safety technology**

■ For more information, please visit: www.boschrexroth.com/cat-cxx02

Technical specifications					
Type	CSB02.1A-ET	CSB02.xB-ET	CDB02.1B-ET	CSH02.xB-ET	CSH02.xB-CC
Performance	BASIC	BASIC	BASIC	ADVANCED	ADVANCED
Control communication					
Sercos, EtherCAT	–	–	–	–	–
Multi-Ethernet (Sercos, EtherCat, EtherNet/IP, PROFINET IO)	●	●	●	●	○
Sercos master for cross communication	–	–	–	–	●
Analog interface ¹⁾	○	○	○	○	○
PROFIBUS	○	○	○	–	○
CANopen	○	○	○	–	○

Technical specifications						
Type		CSB02.1A-ET	CSB02.xB-ET	CDB02.1B-ET	CSH02.xB-ET	CSH02.xB-CC
Extensions						
Encoder emulation		○	●	●	●	●
Multi-encoder interface		○	○	○	○	○
Encoder emulation with level converter function		○	○	○	○	○
Digital/analog I/O extension		–	○	○	○	○
Additional engineering port		–	–	–	–	●
Operating panel						
Standard operating panel		●	●	●	–	–
Advanced operating panel with memory card slot		○	○	○	●	●
Cycle times						
Current control		125/62.5 μs ²⁾	125/62.5 μs ²⁾	125/62.5 μs ²⁾	62.5 μs	62.5 μs
Speed control		250/125 μs ²⁾	250/125 μs ²⁾	250/125 μs ²⁾	125 μs	125 μs
Position control		500/250 μs ²⁾	500/250 μs ²⁾	500/250 μs ²⁾	250 μs	250 μs
PWM frequency						
2 kHz ³⁾		●	●	●	●	●
4 kHz		●	●	●	●	●
8 kHz		●	●	●	●	●
12 kHz ³⁾		●	●	●	●	●
16 kHz		●	●	●	●	●
Inputs / outputs						
Digital inputs	Total	7	11	14	11	11
	Can be used as probe	2	2	4	2	2
Digital inputs/outputs	Configurable as required	1	5	8	5	5
Analog inputs	±10 V	1	1	2	1	1
	±10 V or 0 ... 20 mA	–	2	–	2	2
Analog outputs	±10 V	–	2	2	2	2
Relay outputs		1	1	1	1	1
Onboard encoder interface						
Multi-encoder interface	Motors (MAD, MAF, MCL, MKE, MS2N, MSK, MSM), Hiperface®, EnDat 2.1, EnDat 2.2, 1 Vpp, 5 V TTL, SSI, Resolver	●	●	●	●	●
Safety options according to EN 13849-1 and EN 62061						
Safe Torque Off	Category 4 PL e/SIL 3	○	○	○	○	○
Safe Motion	Category 3 PL d/SIL 2 or category 4 PL e/SIL 3	–	○	○	○	○
Safe Motion Bus	Category 3 PL d/SIL 2 or category 4 PL e/SIL 3	–	○	○	○	○

● Standard ○ Option

¹⁾ On-board analog input for open-loop applications

²⁾ The cycle time of the BASIC control units CSB and CDB depends on the set firmware performance level (BASIC/ADVANCED)

³⁾ Not available when the firmware performance level "ADVANCED" is used

BASIC single-axis control unit

IndraDrive

CSB02



The BASIC single-axis control unit is suitable for a variety of applications. It supports a wide range of control communication and encoder interfaces.

- ▶ **Multi-Ethernet interface (Sercos, EtherCAT®, PROFINET IO, EtherNet/IP)**
- ▶ **Multi-encoder interface for the evaluation of all standard encoder types**
- ▶ **Optional integrated safety technologies Safe Torque Off or Safe Motion**
- ▶ **Additional equipment option (PROFIBUS, CANopen, encoder emulation, second multi-encoder interface, I/O extension)**
- ▶ **Extensive firmware functions, incl. IEC-conform motion logic**

Type code	
CSB02.xB-ET-EC-NN-L3-EC-NN-FW	
<p>Control unit version</p> <p>CSB = BASIC (double-axis)</p> <p>Interface equipment</p> <p>B = Extended functionality</p> <p>Communication</p> <p>ET = Multi-Ethernet (Sercos III, PROFINET IO, EtherNet/IP, EtherCAT)</p> <p>Encoder</p> <p>EC = Multi-encoder interface</p> <p>Option (axis 1)</p> <p>NN = Not equipped</p> <p>PB = PROFIBUS</p> <p>EC = Multi-encoder interface</p> <p>EM = Encoder emulation</p>	<p style="text-align: right;">Drive software</p> <p>FW = With standard operating panel, drive software must be ordered separately</p> <p>AW = With advanced operating panel, drive software must be ordered separately</p> <p>NW = Without operating panel and firmware</p> <p style="text-align: right;">Option 3</p> <p>NN = Not equipped</p> <p>EC = Multi-encoder interface</p> <p>EM = Encoder emulation</p> <p>DA = I/O extension digital/analog</p> <p style="text-align: right;">Option 2 (safety technology)</p> <p>NN = Not equipped</p> <p>L3 = Safe Torque Off (STO)</p> <p>S4 = Safe Motion</p> <p>S5 = Safe Motion</p> <p>SB = Safe Motion Bus</p>

Available options and technical specifications: see product documentation (project planning instructions in the media directory: www.boschrexroth.com/mediadirectory)

■ For more information, please visit: www.boschrexroth.com/cat-csb02

Electrical connection

Front view

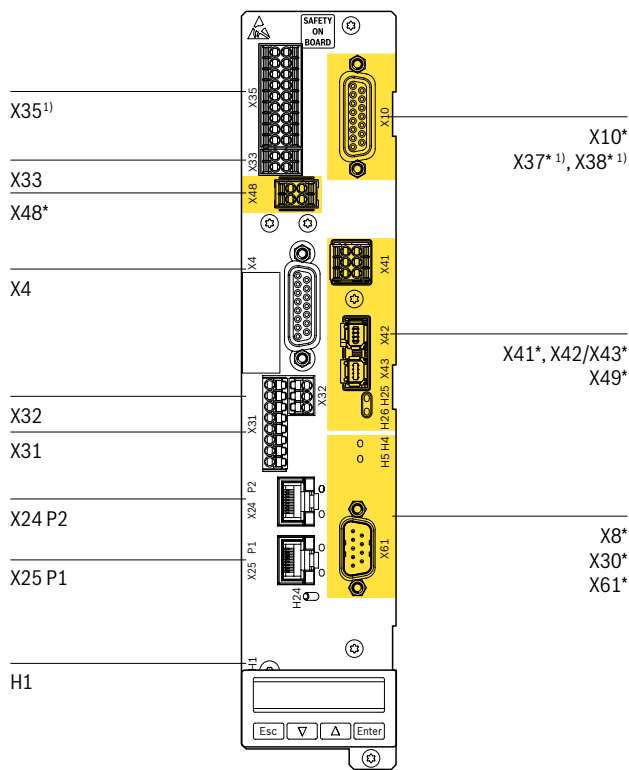

Connection point	Description
X4	Encoder evaluation EC
X8*	Encoder evaluation EC
	Encoder emulation EM
X10*	Encoder evaluation EC
	Encoder emulation EM
X24 P2 X25 P1	Communication Multi-Ethernet ET
X30*	Communication PROFIBUS PB
X31	Digital inputs/outputs
	Probe input
X32	Analog inputs
X33	Voltage input (24 V, 0 V)
	Bb relay
X35 ¹⁾	Digital inputs/outputs
	Analog inputs (current/voltage)
	Analog outputs (voltage)
X37* ¹⁾	Digital inputs/outputs
X38* ¹⁾	Analog inputs/outputs
X41* X42/X43*	S4, S5, SB safety technology (Not required for SB: X41, X42 and X43; LEDs included)
	Safety technology (Only available with S4, S5 and SB safety technology)
X48*	Safety technology (Only available with S4, S5 and SB safety technology)
X49*	L3 safety technology
X61*	CANopen communication CN
H1	Operating panel interface

* Optional connection point; optional connection points are highlighted in yellow in the figure.

¹⁾ CSB02.xB only

BASIC double-axis control unit

IndraDrive

CDB02



The BASIC double-axis control unit is suitable for a variety of applications. It supports a wide range of control communication and encoder interfaces.

- ▶ **Multi-Ethernet interface (Sercos, EtherCAT®, PROFINET IO, EtherNet/IP)**
- ▶ **Multi-encoder interface for the evaluation of all standard encoder types**
- ▶ **Optional integrated safety technologies Safe Torque Off or Safe Motion**
- ▶ **Additional equipment option (PROFIBUS, CANopen, encoder emulation, second multi-encoder interface, I/O extension)**
- ▶ **Extensive firmware functions, incl. IEC-conform motion logic**

Type code	
CDB02.1B-ET-EC-EC-NN-L3-L3-EM-NN-FW	
<p>Control unit version</p> <p>CDB = BASIC (double-axis)</p> <p>Interface equipment</p> <p>B = Extended functionality</p> <p>Communication</p> <p>ET = Multi-Ethernet (Sercos III, PROFINET IO, EtherNet/IP, EtherCAT)</p> <p>Encoder</p> <p>EC-EC = Multi-encoder interface</p> <p>Option (axis 1)</p> <p>NN = Not equipped</p> <p>PB = PROFIBUS</p> <p>EC = Multi-encoder interface</p> <p>EM = Encoder emulation</p>	<p>Drive software</p> <p>FW = With standard operating panel, drive software must be ordered separately</p> <p>AW = With advanced operating panel, drive software must be ordered separately</p> <p>Option (axis 2)</p> <p>NN = Not equipped</p> <p>EC = Multi-encoder interface</p> <p>EM = Encoder emulation</p> <p>DA = I/O extension digital/analog</p> <p>Option 2 (safety technology)</p> <p>NN-NN = Not equipped</p> <p>L3-L3 = STO (Safe Torque Off)</p> <p>S4-S4 = Safe Motion</p> <p>S5-S5 = Safe Motion</p> <p>SB-SB = Safe Motion Bus</p>

Available options and technical specifications: see product documentation (project planning instructions in the media directory: www.boschrexroth.com/mediadirectory)

■ For more information, please visit: www.boschrexroth.com/cat-cdb02

Electrical connection

Front view	Connection point ¹⁾	Description	
	X4.1	Encoder evaluation EC	
	X4.2	Encoder evaluation EC	
	X8*	Encoder evaluation EC Encoder emulation EM	
	X10*	Encoder evaluation EC Encoder emulation EM	
	X24 P2 X25 P1	Communication Multi-Ethernet ET	
	X30*	Communication PROFIBUS PB	
	X31	Digital inputs/outputs Probe input	
	X32	Analog inputs	
	X33	Voltage input (24 V, 0 V) Bb relay	
	X36	Digital inputs/outputs Analog outputs (voltage)	
	X37*	Digital inputs/outputs	
	X38*	Analog inputs/outputs	
	X41.1* X41.2*	S4, S5, SB safety technology (Not required for SB: X41, X42 and X43; LEDs included)	
	X42.1/X43.1* X42.2/X43.2*		
	X48.1* X48.2*	Safety technology (Only available with S4, S5 and SB safety technology)	
	X49.1* X49.2*	L3 safety technology	
	H1	H1	Operating panel interface

* Optional connection point; optional connection points are highlighted in yellow in the figure.

¹⁾ Connection points of axis 1 have the suffix ".1" (e.g.: X4.1); connection points of axis 2 have the suffix ".2" (e.g.: X4.2)

ADVANCED single-axis control unit

IndraDrive

CSH02



The ADVANCED single-axis control units meet the highest requirements for control standards and dynamism. It supports a wide range of control communication and encoder interfaces. Digital and analog inputs and outputs are integrated for communication with the higher-level control and can be extended by digital and analog I/O extensions and encoder emulation outputs. The ADVANCED control unit is the ideal platform for the drive-integrated Motion Logic MLD.

- ▶ **Sercos master or Multi-Ethernet interface**
- ▶ **Multi-encoder interface for all common encoders**
- ▶ **Optional integrated safety technologies Safe Torque Off or Safe Motion**
- ▶ **Two additional equipment options (PROFIBUS, CANopen, encoder emulation, second/third multi-encoder interface, I/O extension)**
- ▶ **Extensive firmware functions, incl. IEC-compliant motion logic**

Type code	
CSH02.xB-CC-EC-ET-L3-EC-NN-FW	
Control unit version CSH = ADVANCED	Drive software FW = With standard operating panel, drive software must be ordered separately NW = Without operating panel and firmware
Interface equipment B = Extended functionality	Option 3 NN = Not equipped EC = Multi-encoder interface EM = Encoder emulation DA = I/O extension digital/analog
Communication CC = Sercos III Master ET = Multi-Ethernet (Sercos III, PROFINET IO, EtherNet/IP, EtherCAT)	Option 2 (safety technology) NN = Not equipped L3 = Safe Torque Off (STO) S4 = Safe Motion S5 = Safe Motion SB = Safe Motion Bus
Encoder EC = Multi-encoder interface	
Option 1 NN = Not equipped ET = MultiEthernet PB = PROFIBUS CN = CANopen EC = Multi-encoder interface EM = Encoder emulation	

Available options and technical specifications: see product documentation (project planning instructions in the media directory: www.boschrexroth.com/mediadirectory)

■ For more information, please visit: www.boschrexroth.com/cat-csh02

Electrical connection

Front view

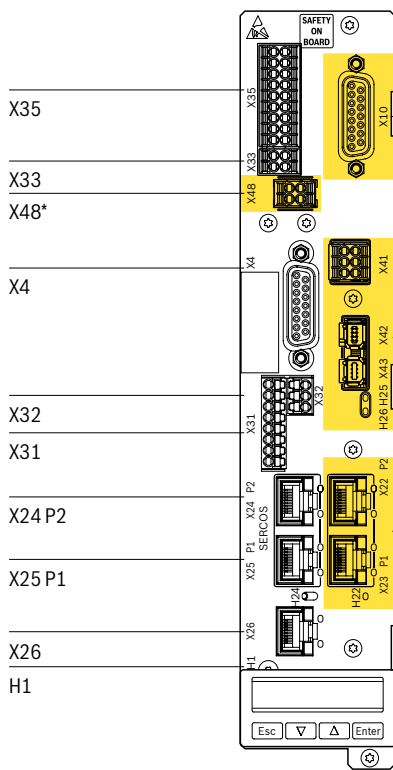

Connection point	Description
X4	Encoder evaluation EC
X8*	Encoder evaluation EC Encoder emulation EM
X10*	Encoder evaluation EC Encoder emulation EM
X22 P2 X23 P1*	Communication Multi-Ethernet ET
X24 P2 X25 P1	Sercos III Master CC Multi-Ethernet ET
X26	Engineering interface (Only available in CSH02.xB-CC)
X30*	Communication PROFIBUS PB
X31	Digital inputs/outputs Probe input
X32	Analog inputs
X33	Voltage input (24 V, 0 V) Bb relay
X35	Digital inputs/outputs Analog inputs (current/voltage) Analog outputs (voltage)
X37*	Digital inputs/outputs
X38*	Analog inputs/outputs
X41* X42/X43*	S4, S5, SB safety technology (Not required for SB: X41, X42 and X43; LEDs included)
X48*	Safety technology (Only available with S4, S5 and SB safety technology)
X49*	L3 safety technology
X61*	CANopen communication CN
H1	Operating panel interface

* Optional connection point; optional connection points are highlighted in yellow in the figure.

IndraDrive software

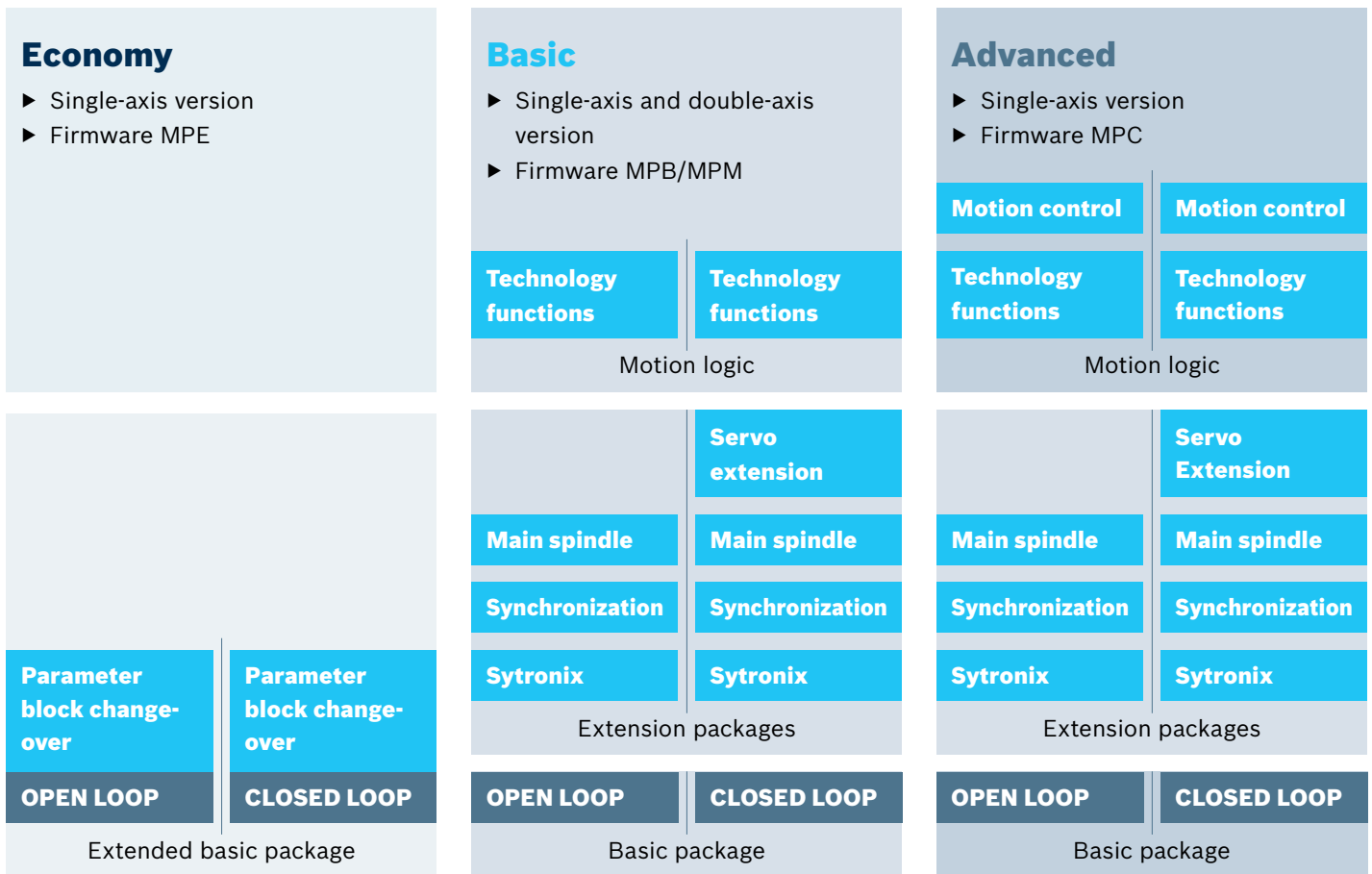

Thanks to its comprehensive range of automation functions, the IndraDrive software offers all the levels of freedom for the cost-effective realization of individual applications.

In the IndraDrive single-axis and multi-axes, the drive software provides various control types for speed, position, and force as well as positioning block mode. The drive software supports these control modes with extensive limitation, monitoring and diagnostics functions and also

enables the use of various encoder systems and profiles. Numerous extension packages such as electronic cams, gears, motion profiles or spindle positioning simplify the realization of demanding drive tasks.

In the supply units of the IndraDrive ML and IndraDrive Mi series, the drive software PSB enables the user to implement application-specific energy-saving concepts even with the basic functions.

In addition, extension packages offer specific functions for use in applications such as power generation, battery charging and testing, the coupling of different energy storage systems, etc.

The innovative interface technology Open Core Interface enables simple data exchange and interplay between the components of the IT and automation world. Systems can thus be easily interlinked and at the same time transparency in manufacturing can be increased.

Both rotary and linear 3rd-party motors can be integrated into the automation solution to meet special design or safety requirements.

Service and diagnostics functions round off the range and are available to end-users and service staff quickly and easily via a web interface.

MPx drive software for IndraDrive control units with axis control function

- ▶ Flexible scope of functions for individual applications
 - OPEN LOOP basic package for sensorless and cost-effective frequency converter applications with lower demands on control quality and dynamism
 - Basic package CLOSED LOOP for servo and frequency converter applications with medium to high demands on control performance
 - Wide range of applications thanks to optional extension packages: electronic synchronization, additional servo functions, main spindle operation or functions for hydraulic applications
 - Subsequently loadable technology functions or customer-specific applications freely programmable in IEC-61131-compliant motion logic

- ▶ Versatile operation modes for high-precision automation
 - Force control
 - Speed control
 - Position control
 - Positioning block mode with maximum repeatability
- ▶ Position control and bus cycle performance of at least 250 µs
- ▶ Vibration suppression filter
- ▶ Integrated IEC-conform motion logic
- ▶ Certified safety technology up to level Cat. 4, PL e, SIL 3
- ▶ Manufacturer-independent Sercos and CANopen CiA 402 device profile

PSB drive software for IndraDrive Mi/ML control units with power control function

- ▶ Various operating modes are available in the basic package to execute the supply function
 - Control of the DC bus voltage to configurable, constant value
 - Control of the DC bus voltage in a configurable tolerance range
 - Voltage control shutdown depending on the load
 - Line current control with separate specification of the mains-side effect and reactive current
- ▶ Smart energy mode to avoid peak loads
- ▶ Power operation for supplying energy in low and medium voltage networks
- ▶ Island grid mode for controlling voltage and frequency in an island grid
- ▶ DC/DC regulator for generating an adjustable DC voltage
- ▶ IndraMotion MLD for programming application-specific solutions

Drive software

IndraDrive

MPx/PSB

Type code	
FWA-INDRV*-MPB-21VRS-D5-1-NNN-NN	
<p>Version</p> <p>MPE = ECONOMY MPB = BASIC MPC = ADVANCED MPM = BASIC (double-axis) PSB = Power supply BASIC (supplier)</p> <p>Version</p> <p>E.g. 21 = 21</p> <p>Release</p> <p>RS = Current release</p> <p>Language mark</p> <p>D5 = DE/EN/FR/IT/ES</p> <p>Control mode</p> <p>0 = Open Loop 1 = Closed Loop E = Export-limited</p>	<p>Drive PLC (MLD)</p> <p>NN = Not activated TF = Technology functions ML = Motion logic STANDARD MA = Motion logic ADVANCED</p> <p>Extension package</p> <p>NNN = Without extension MSP = Main spindle function SNC = Synchronization SRV = Servo function SYX = Sytronix ALL = Expansion freely selectable MSE = Network function extension (supplier) DCE = DC extension (supplier)</p>

Available options and technical specifications: see product documentation (project planning instructions in the media directory: www.boschrexroth.com/mediadirectory)

■ For more information, please visit: www.boschrexroth.com/cat-id-fw

Technical specifications						
Type	FWA-INDRV*-MPE-...		FWA-INDRV*-MPB-... FWA-INDRV*-MPM-...		FWA-INDRV*-MPC-...	
Performance level	ECONOMY		BASIC		ADVANCED	
Control mode	OPEN LOOP	CLOSED LOOP	OPEN LOOP	CLOSED LOOP	OPEN LOOP	CLOSED LOOP
Basic packages						
Basic functions, general						
Electronic type plate	●	●	●	●	●	●
Automatic circuit adjustment	–	●	–	●	●	●
Travel to fixed stop	●	●	●	●	●	●
Configurable error reaction (package reaction, NC reaction, MLD reaction)	●	●	●	●	●	●
Brake control	●	●	●	●	●	●
Oscilloscope function	●	●	●	●	●	●
Drive stop	●	●	●	●	●	●

■ For more information, please visit: www.boschrexroth.com/cat-id-fw

Technical specifications						
Type	FWA-INDRV*-MPE-...		FWA-INDRV*-MPB-... FWA-INDRV*-MPM-...		FWA-INDRV*-MPC-...	
Performance level	ECONOMY		BASIC		ADVANCED	
Control mode	OPEN LOOP	CLOSED LOOP	OPEN LOOP	CLOSED LOOP	OPEN LOOP	CLOSED LOOP
Command value reset (emergency stop)	●	●	●	●	●	●
Command value reset with ramp and filter (quick stop/emergency stop)	●	●	●	●	●	●
Torque disable	●	●	●	●	●	●
E-Stop function	●	●	●	●	●	●
Parking axis	●	●	●	●	●	●
Basic functions OPEN LOOP						
Speed control	●	●	●	●	●	●
Motor control with V/f curve, incl. slip compensation I x R compensation and stall protection	●	●	●	●	●	●
Use of frequency-controlled operation (V/f) of sensorless three-phase asynchronous motors	●	●	●	●	●	●
Flux-controlled, encoder-free operation (FXC) of three-phase motors	–	–	●	●	●	●
Field-based current control of three-phase motors with motor encoder (FOC)	–	●	–	●	–	●
Field-based current control of encoder-free three-phase motors (FOCsl)	–	●	–	●	–	●
Basic functions CLOSED LOOP						
Torque/force control	–	●	–	●	–	●
Speed control	●	●	●	●	●	●
Position control	–	●	–	●	–	●
Drive-controlled positioning	–	●	–	●	–	●
Drive-internal interpolation	–	●	–	●	–	●
Positioning block mode	–	●	–	●	–	●
Friction torque compensation	–	●	–	●	–	●
Temperature error correction	–	●	–	●	–	●
Backlash on reversal correction	–	–	–	●	–	●
Redundant motor encoder	–	–	–	●	–	●
Set/shift coordinate system	–	–	–	● ¹⁾	–	●
Automatic commutation setting	–	●	–	●	–	●
Position switch point with switch-on and switch-off threshold	–	●	–	●	–	●
Encoder emulation, incremental or absolute (SSI format)	–	●	–	●	–	●
Automatic weight load determination	–	–	–	●	–	●
Parameter set switching	–	● ²⁾	–	–	–	–

MPx

■ For more information, please visit: www.boschrexroth.com/cat-id-fw

Technical specifications						
Type	FWA-INDRV*-MPE-...		FWA-INDRV*-MPB-... FWA-INDRV*-MPM-...		FWA-INDRV*-MPC-...	
Performance level	ECONOMY		BASIC		ADVANCED	
Control mode	OPEN LOOP	CLOSED LOOP	OPEN LOOP	CLOSED LOOP	OPEN LOOP	CLOSED LOOP
Extension packages						
Servo extension						
Relative retraction movement	–	–	–	● ¹⁾	–	●
Precision axis error correction	–	–	–	● ¹⁾	–	●
Temperature error correction	–	–	–	●	–	●
Quadrant error correction	–	–	–	●	–	●
Detent torque compensation	–	–	–	●	–	●
Probe with fast stop	–	–	–	1	–	2
Dynamic programmable limit switch	–	–	–	● ¹⁾	–	●
Parameter set switching	–	● ³⁾	●	●	●	●
Main spindle						
Parameter set switching	–	● ³⁾	●	●	●	●
Spindle positioning	–	–	–	●	–	●
Drive-controlled oscillation (for gear switching)	–	–	●	●	●	●
Synchronization						
Speed synchronization	–	–	●	●	●	●
Angle synchronization	–	–	–	●	–	●
Electronic cams	–	–	–	●	–	●
Electronic motion profile	–	–	–	●	–	●
Detent torque compensation	–	–	–	●	–	●
Measuring wheel mode	–	–	–	●	–	●
Measuring encoder	–	–	● ¹⁾	●	●	●
Real and virtual master axis	–	–	●	●	●	●
Probe with time measurement	–	–	1	–	1	–
Probe with synchronization function	–	–	–	1	–	2
Dynamic programmable limit switch	–	–	–	● ¹⁾	–	●
Technology functions						
Process control	–	–	○	○	○	○
Sequential programming SMC (incl. axis coupling, flying shear)	–	–	○	○	○	○
Winder	–	–	○	○	○	○

Technical specifications							
Type	FWA-INDRV*-MPE-...		FWA-INDRV*-MPB-... FWA-INDRV*-MPM-...		FWA-INDRV*-MPC-...		
Performance level	ECONOMY		BASIC		ADVANCED		
Control mode	OPEN LOOP	CLOSED LOOP	OPEN LOOP	CLOSED LOOP	OPEN LOOP	CLOSED LOOP	
Tension control	–	–	○	○	○	○	
Cross cutters	–	–	○	○	○	○	
Register control	–	–	○	○	○	○	
Slotter	–	–	○	○	○	○	
Kinetic buffering (incl. simulation with Simster; running memory BANF must be ordered separately)	–	–	○	○	○	○	
Motion control							
MLD	Information on the drive-integrated motion control system MLD can be found in the automation software chapter starting from page 42.						
Open Core interface for drives for programming in the following tools							
Microsoft Visual Studio	with C#, VB, F#, C/C++	●	●	●	●	●	●
	with C# on VR21 and VEP	●	●	●	●	●	●
Embarcadero RAD Studio	with Delphi, C/C++	●	●	●	●	●	●
Eclipse (Eclipse Foundation)	with C/C++, Java	●	●	●	●	●	●
Microsoft Office	with VBA with Excel, Access	●	●	●	●	●	●
Apple Xcode	in C	●	●	●	●	●	●
Android Studio	with Java for the app generation	●	●	●	●	●	●
Microsoft Visual Studio with Xamarin extension	with C# for app generation	●	●	●	●	●	●
National Instruments LabVIEW		●	●	●	●	●	●
MathWorks MATLAB		●	●	●	●	●	●
Further tools on request		●	●	●	●	●	●

● Standard ○ Option

¹⁾ Not for double-axis control unit/MPM firmware

²⁾ Extended basic package (ECONOMY only)

³⁾ Included in the basic package

PSB

■ For more information, please visit: www.boschrexroth.com/cat-id-fw

Technical specifications	
Type	FWA-INDRV*-PSB-...
Basic functions	
Voltage control	●
Voltage control, floating DC bus voltage	●
Rectifier mode, load-dependent	●
Mains current control	●
Extension packages	
Mains functional extension	
Expanded mains monitoring	●
Power limitation	●
Frequency-dependent active power limitation	●
Reactive power command value depending on the active power	●
Island grid operation	●
DC expansion	
Current control	●
Voltage control	●



IndraDrive safety technology

SafeMotion is the prerequisite for the realization of safe machine concepts. The drive-integrated safety technology shows how man, machine and product can be protected at the highest level while at the same time increasing productivity, ergonomics and efficiency in engineering.

With the “Safe Torque Off” safety option, the frequency converters of the EFC5610 series offer safe torque release of the drives. SafeMotion includes a large number of additional certified functions across all IndraDrive drive series. These include, among other things, a safe door locking and a safe braking and holding system. To enable performance-enhancing functions for machine safety, SafeMotion supports a total of 16 safe absolute position ranges and up to 31 safe cams.

- ▶ **Safe logic functions integrated in the drive**
- ▶ **Drive-integrated safety functions for braking, holding, moving and position monitoring**
- ▶ **Continuously from 100 W to 4 MW for all Indra Drive product families Cs, C, M, ML, Mi, as well as the frequency converters EFC5610**
- ▶ **Maximum safety level (Cat. 4, PL e, SIL 3) for nearly all safety functions**
- ▶ **Safety functions can be selected via CIP Safety on Sercos or EtherNet/IP, Fail Safe over EtherCat, PROFIsafe on PROFINET, or via discrete 24 V signals**
- ▶ **4.5 ms quick response time**

**SAFETY
ON
BOARD**

- ▶ **SafeMotion**
Drive-integrated and certified safety technology for maximum protection of man, machine, tool and work piece



SafeMotion IndraDrive



The drive-integrated safety technology from Bosch Rexroth forms the basis for avoiding unwanted machine movements. From simple Safe Torque Off (STO) with or without Safe Brake Control (SBC) to comprehensive safety functions for safe braking, holding, moving and position monitoring, SafeMotion provides customized safety solutions for a wide range of machines and systems.

- ▶ **Maximum safety level (Cat. 4, PL e, SIL 3) for all safety functions**
- ▶ **Safe absolute end position replaces hardware limit switches by software**
- ▶ **31 safe cam ranges configurable**
- ▶ **Reduced commissioning effort thanks to semiautomatic support**
- ▶ **Device swap without PC in case of servicing**

■ For more information, please visit: www.boschrexroth.com/cat-id-saf

Functions	
<p>Safe Torque Off (STO)</p> <p>▶ torque safely switched off</p> <p>Stop Category 0 as per EN 60204-1: safe drive torque release</p>	
<p>Safe Brake Control (SBC)</p> <p>▶ safe control of the brakes</p> <p>For safe actuation of an electrically releasing holding brake.</p>	
<p>Safe Braking and Holding System (SBS)</p> <p>The Safe Braking and Holding System controls, monitors and tests two independent brakes</p>	

Functions	
<p>Safe Operating Stop (SOS), Safe Stop 2 (SS2-r)</p> <p>▶ safe standstill monitoring</p> <p>▶ safe stop 2 ramp-monitored</p> <p>Stop Category 2 as per EN 60204-1: safely monitored stopping with safely monitored standstill and controlled torque</p>	
<p>Safe Stop 1 (SS1-t)</p> <p>▶ safe stop 1 time-controlled</p> <p>Stop Category 1 as per EN 60204-1: safely monitored stopping, control-guided or drive-guided with safe drive torque release</p>	
<p>Safe Stop 1 (SS1-r)</p> <p>▶ safe stop 1 ramp-monitored</p> <p>Stop Category 1 as per EN 60204-1: safely monitored stopping with safely monitored standstill and controlled torque</p>	

Functions

Safely Monitored Deceleration (SMD)

Safe monitoring of deceleration on stopping with predetermining characteristics

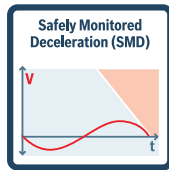

Safe Brake Test (SBT)

To test the holding function of the connected brakes

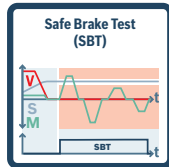

Safe Limited Speed (SLS)

If enabled signal is given, a safely limited speed is monitored in special operating mode



Safe Monitored Oscillation (SLS-LT)

Prevents the drive from not exceeding a preset speed limit value for longer than a preset time by means of two-channel monitoring

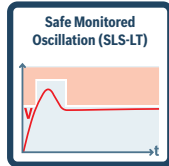

Safe Speed Monitor (SSM)

Safe output signal when the actual speed is within a defined speed window



Safe Maximum Speed (SMS)

The maximum speed is safely monitored regardless of operation mode



Safe Direction (SDI)

In addition to safe movement, the direction (left, right) is safely monitored

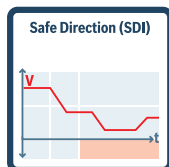

Functions

Safely Limited Increment (SLI)

With consent, a limited increment is safely monitored in special operating mode



Safe Limited Position (SLP, SLE)

► **safely limited position and end position**
Monitoring of safe software limit switches in special operation mode or in all modes



Safe Monitored Position (SMP)

In addition to safe movement, the absolute position range is safely monitored

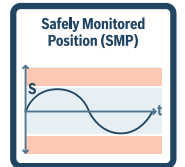

Safe Cam (SCA)

Safe output signal for up to 31 cam ranges



Safe Door Locking (SDL)

When all drives in a safety zone are secure, the safe door locking is unlocked



Safe inputs/outputs (SIO)

For selecting safety functions or to provide the status via safety bus to the control; connection of safety peripherals via two channels locally at the drive or decentralized via the safety zone module

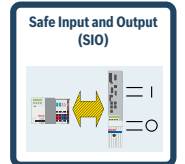

Safe Communication (SCO)

For selecting/deselecting the safety functions via a safe fieldbus



SafeMotion

■ For more information, please visit: www.boschrexroth.com/cat-id-saf

Technical specifications			Safety option					Safety level up to ¹⁾
Safety functions			L3	L4	S4/S5	SB	SD	
Safe Standstill	STO	Safe Torque Off	●	●	●	●	●	Cat. 4, PL e, SIL 3
	SBC	Safe Brake Control	–	●	●	●	●	
	SOS	Safe Operating Stop	–	–	●	●	●	
	SBS ²⁾	Safe Braking and Holding System	–	–	●	●	●	Cat. 3, PL d, SIL 2
Safe Shutdown	SS1-t	Safe Stop 1 – time-controlled	–	–	●	●	●	Cat. 4, PL e, SIL 3
	SS1-r	Safe Stop 1 – ramp-monitored	–	–	●	●	●	
	SS2-r	Safe Stop 2 – ramp-monitored	–	–	●	●	●	
	SMD ²⁾	Safely Monitored Deceleration	–	–	●	●	●	
Diagnostics function	SBT ²⁾	Safe Brake Test	–	–	●	●	●	–
Safe Movement	SLS	Safely Limited Speed	–	–	●	●	●	Cat. 4, PL e, SIL 3
	SLS-LT	Safely Monitored Oscillation	–	–	●	●	●	
	SSM	Safe Speed Monitor	–	–	●	●	●	
	SMS ²⁾	Safe Maximum Speed	–	–	●	●	●	
	SDI	Safe Direction	–	–	●	●	●	
	SLI	Safely Limited Increment	–	–	●	●	●	
Safe Position	SLP	Safely Limited Position	–	–	●	●	●	Cat. 3, PL d, SIL 2
	SMP ²⁾	Safely Monitored Position	–	–	●	●	●	
	SLE ²⁾	Safely Limited End Position	–	–	●	●	●	
	SCA	Safe Cam	–	–	●	●	●	
Safe Locking	SDL ²⁾	Safe Door Locking	–	–	●	–	–	Cat. 4, PL e, SIL 3
Safe inputs/outputs	SIO ²⁾	Safe Input Output	–	–	●	–	–	

¹⁾ According to EN 13849-1 and EN 62061

²⁾ Not defined in EN 61800-5-2

Technical specifications		L3	L4	S4/S5	SB	SD
Safety options		STO	STO/SBC	SafeMotion	SafeMotion	SafeMotion
In the series	EFC5610	●	–	–	–	–
	IndraDrive Cs	●	●	●	●	–
	IndraDrive C	●	–	●	●	–
	IndraDrive M	●	–	●	●	–
	IndraDrive ML	●	–	●	●	–
	IndraDrive Mi	●	–	–	–	●
Selection via	24 V inputs on-board	●	●	●	–	●
	24 V inputs at the safety zone module	–	–	●	–	–
Safe communication SCO	CIP Safety on Sercos	–	–	●	●	●
	FailSafe over EtherCAT	–	–	●	●	●
	PROFIsafe on PROFINET	–	–	●	●	●
	CIP Safety on EtherNet/IP	–	–	●	●	●

Components for implementation of drive-based safety technology		
Frequency converters	EFC5610	Page 202
BASIC single-axis control unit	CSB02	Pages 264, 266
BASIC double-axis control unit	CDB02	Pages 264, 268
ADVANCED single-axis control unit	CSH02	Pages 264, 270
Drive software MPx	FWA-INDRV*-Mxxx	Page 272 , 274
IndraWorks Engineering	SWA-IWORKS	Page 374

Motors and gearboxes

The comprehensive portfolio of servo and kit motors and gearboxes by Bosch Rexroth convinces with a unique variety of designs, versions and performances. Combined with the high-performance Bosch Rexroth drive technology, almost all requirements in modern factory

automation can be met – regardless of whether rotary or linear motions are involved, highest forces, accelerations and speeds are required, or special requirements regarding explosion protection have to be met.



Servo motors and planetary gearboxes 288

Synchronous servo motor – MS2N	290
Synchronous servo motor – MS2E	302
Synchronous servo motor – MKE	306
Synchronous servo motor – MSM	310
Asynchronous servo motor – MAD	312
Asynchronous servo motor – MAF	318
Servo planetary gearbox – GTE	324
Servo planetary gearbox – GTM	330

Kit motors 336

Synchronous linear motor – MCL	338
Synchronous linear motor – ML3	342
Synchronous linear motor – MLF	346
Synchronous torque motor – MBT	352
Synchronous high-speed motor – MBS	358
Asynchronous high-speed motor – 1MB	364

Servo motors and planetary gearboxes

Bosch Rexroth's comprehensive portfolio of servo motors and gearboxes offers outstanding performance as well as a unique variety of designs, versions and performances. In combination with intelligent drive units, it perfectly solves automation applications in modern factory automation – high-dynamic, precise and reliable.

Compact synchronous servo motors and robust asynchronous servo motors in housed design meet all requirements from standard application to high-end applications. The innovative single-cable connection technology of our synchronous servo motors simplifies installation. Fine resolution encoder systems and outstanding radial runout ensure consistently high machining quality. ATEX- and UL/CSA-certified motors for hazardous areas round off the motor portfolio.

- ▶ **Comprehensive motor portfolio for all rotary and translatory movements**
- ▶ **Robust designs with high dynamism for economical production**
- ▶ **Single cable connection technology for quick and easy installation**
- ▶ **Wide range of application-specific options such as type of cooling, encoder systems, holding brakes, etc.**
- ▶ **Certified explosion protection versions according to ATEX and UL/CSA**
- ▶ **Integrated gearbox portfolio for standard and high-end applications**



- ▶ **MSM synchronous servo motor**
High power density with particularly short length and for IndraDrive Cs compact drives



- ▶ **Synchronous servo motors MS2N**
Higher torque, higher speeds, practical single cable connection and intelligent encoder systems – ideal for Industry 4.0 applications



- ▶ **Synchronous servo motors MS2E**
MS2E motors offer the highest dynamism and safety in ATEX applications for dusts and gases up to equipment group II and equipment category 3



- ▶ **Synchronous servo motors MKE**
MKE motors for maximum safety in ATEX applications in which explosive mixtures can develop from combustible gases and dust up to equipment group II and equipment category 2



▶ **Asynchronous servo motors
MAD**

Force-ventilated, powerful motors, ideal e.g. for servo and main spindle applications in machine tools, printing machines, or metal forming



▶ **Asynchronous servo motors
MAF**

Water-cooled and therefore ideal for applications that require thermal isolation of motor and machine as well as the highest torques in a confined space



▶ **Servo planetary gearboxes
GTE**

Compact planetary gearboxes for easy handling and automation systems with pinion, rack and tooth belt drives



▶ **Servo planetary gearboxes
GTM**

High-precision planetary gearboxes with minimal torsional backlash and high levels of efficiency – ideal for S1 continuous operation, e.g. in printing machines



Synchronous servo motor

MS2N



More torque, higher speeds, the practical single cable connection and an extensive range of options: This generation of MS2N motors by Rexroth combines high dynamism with compact dimensions and best energy efficiency. Rotors with low and medium inertia are available with optimum mass customization. For intelligent solutions in the Industry 4.0 environment, MS2N motors serve as data sources.

- ▶ **Maximum torque (M_{\max}) up to 360 Nm**
- ▶ **Maximum speed (n_{\max}) up to 9 000 min⁻¹**
- ▶ **Increased continuous power due to optional forced ventilation and water cooling**
- ▶ **4 encoder performance levels**
- ▶ **Single cable connection up to 75 m cable length**

Servo motors of the new generation

With more than 50 motor types, the MS2N motor series from Bosch Rexroth covers maximum torques of up to 360 Nm and maximum speeds up to 9 000 min⁻¹.

By means of an optimized electromagnetic design and motor construction, a high power density is achieved. With the finely graduated torque and speed range, application-compatible encoder options and optional single cable connection, the motors flexibly comply with the diverse requirements of modern automation. Forced ventilation and water cooling open up new power ranges.

Intelligent within the system

In the MS2N series, the intelligence makes its way right to the motor. The individual measurements of each individual motor as well as the saturation and temperature data are stored in the respective motor data memory and are processed by IndraDrive control in real time. This increases the torque accuracy considerably and reduces the tolerance range during operation to a fraction of the previously usual values. This allows the servo motor to be used as a reliable sensor and data source. In this way, applications in the Industry 4.0 environment can be implemented cost-effectively and without additional components.

Maximum safety in design and operation

The MS2N motor model in the IndraSize engineering tool enables simple, fast and safe drive design that corresponds exactly to real operation. This enables machine builders to optimally design the drives. The integrated encoders with up to SIL3 PLe ensure maximum safety in SafeMotion applications.

Higher torque and higher speeds

Short winding heads and a high groove filling factor enable compact dimensions with minimum power dissipation. This leads to significantly improved energy efficiency and sustainably reduces operating costs. The field weakening mode available in conjunction with IndraDrive control extends the usable torque-speed range beyond the voltage limit.

Self-cooled, force-ventilated or water-cooled

Motors with integrated fans or water cooling are available from sizes MS2N07. This considerably improves the continuous power with the same size. The blower motors have degree of protection IP65, an integrated temperature sensor with UL-certified intrinsic safety and optionally 115 V or 230 V connection voltage.

Water-cooled motors offer increased continuous torques and ultra-high power density, ideal for new machine concepts with minimal space requirements and high demands on effective heat dissipation. The robust design of the entire motor cooling in stainless steel enables easy and reliable integration into a wide range of cooling circuit systems.

Connection technology

Whether conventional wiring is fitted with compact rotary connectors or a more modern single cable connection, MS2N offers practical variety for less installation effort and space requirements. The size MS2N10 is alternatively also available with terminal box. All connectors are equipped with a comfortable quick connection and can be rotated up to and including size M40.

MS2N

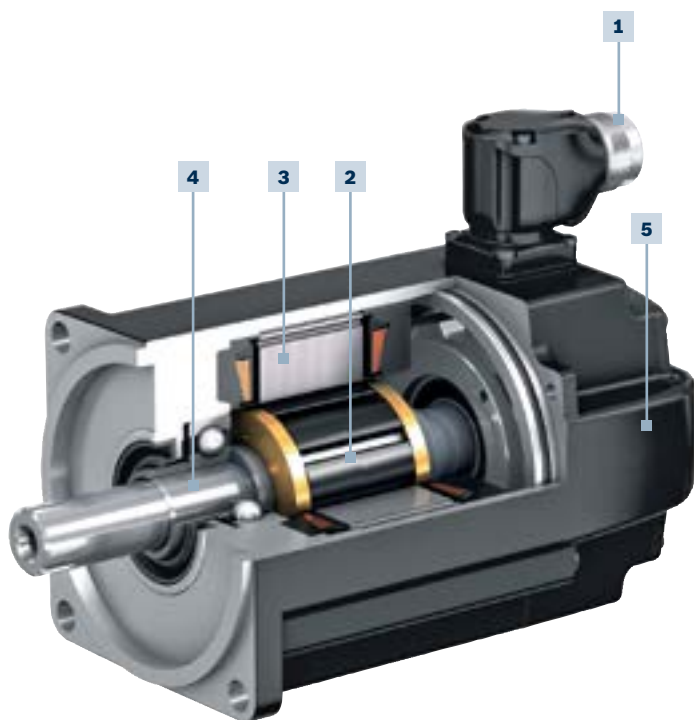

1 One-cable connection

- ▶ Up to 75 m cable length without additional components
- ▶ Plug with quick-lock
- ▶ Optional dual-cable connection

2 Two motor types

- ▶ Low rotor inertia for all sizes
- ▶ Medium rotor inertia from MS2N06

3 Powerful

- ▶ Compact motors
- ▶ High torque density
- ▶ Wide speed range
- ▶ High energy efficiency
- ▶ Optionally forced ventilation and water cooling

4 Flexibly configurable

- ▶ Smooth shaft, keyway, shaft seal ring
- ▶ Degree of protection IP64, IP65 or IP67
- ▶ Energy-saving holding brake
- ▶ Increased flange accuracy
- ▶ and much more

5 Encoder types

- ▶ Four performance levels
- ▶ Safety technology up to SIL3 PLe
- ▶ Single or multi-turn
- ▶ Encoder data memory

Type code
MS2N05-C 0 BN N-A S D H 0-N N N N N-NN

Frame size

03, 04, 05, 06, 07, 10

Frame length

B, C, D, E, F

Rotor inertia

0 = Low inertia
 1 = Medium inertia

Winding

BD = 1 000 min⁻¹ BQ = 4 000 min⁻¹
 BF = 1 500 min⁻¹ BR = 4 500 min⁻¹
 BH = 2 000 min⁻¹ BT = 6 000 min⁻¹
 BN = 3 000 min⁻¹ BY = 9 000 min⁻¹

Type of cooling

N = Self-cooling
 A = Forced ventilation, axial fan 230 V
 B = Forced ventilation, axial fan 115 V
 L = Water cooling

Encoder performance

A = BASIC: 16 signal periods, Hiperface®
 B = STANDARD: 128 signal periods, Hiperface®, SIL2
 C = ADVANCED: digital 20-bit, ACURO®link, SIL2
 H = ADVANCED: digital 20-bit, ACURO®link, SIL3
 D = HIGH: digital 24-bit, ACURO®link, SIL3

Encoder design

S = Single-turn, 1 rotation absolute
 M = Multi-turn, 4 096 rotations absolute

Other version

N = None
 P = Air-pressure connector kit
 E = Additional grounding connection

Coating

N = Standard

Design

N = IM B5/IM 3001, sensor PT1000

Bearing

N = Standard

Flange accuracy

N = Standard
 R = Increased precision

Holding brake

0 = Without holding brake
 1, 2, 3 = With holding brake

Shaft

H = Smooth, without shaft seal ring
 G = Smooth, with shaft seal ring
 L = Keyway, without shaft seal ring
 K = Keyway, with shaft seal ring

Electrical connection

D = Double plug M17, rotatable
 S = Single cable connection M23, rotatable
 U = Angle plug M23, rotatable
 V = Angle plug M40, rotatable
 A = Angle plug M58, side A
 B = Angle plug M58, side B
 T = Terminal box, size 1
 C = Terminal box, size 2

Available options and technical specifications: see project planning instructions: www.boschrexroth.com/cat-ms2n

MS2N Self-cooling

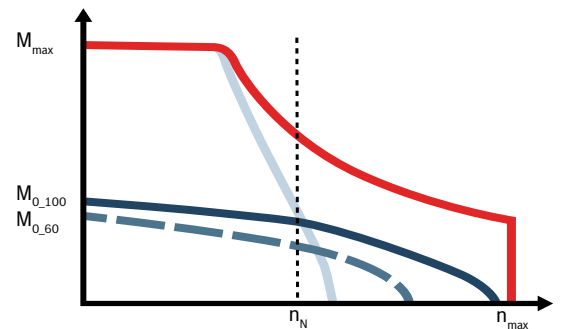

■ For more information, please visit: www.boschrexroth.com/cat-ms2n

Technical specifications										
Type	Rated speed	Maximum speed	Standstill torque		Maximum torque	Continuous standstill current		Maximum current	Moment of inertia	
			60 K	100 K		60 K	100 K		Without brake	With Brake
	n_N	n_{max}	M_{0_60}	M_{0_100}	M_{max}	I_{0_60}	I_{0_100}	I_{max}	$J_{R. w/o.br.}$	$J_{R. w.br.}$
	min ⁻¹	min ⁻¹	Nm	Nm	Nm	A	A	A	kg·m ²	kg·m ²
MS2N03-BOBYN	6 470	9 000	0.73	0.90	3.75	1.31	1.61	7.25	0.000023	0.000030
MS2N03-DOBYN	5 700	9 000	1.15	1.45	7.40	2.07	2.60	14.50	0.000037	0.000044
MS2N04-BOBNN	3 000	6 000	1.75	2.15	6.40	1.11	1.36	4.90	0.000070	0.000110
MS2N04-BOBTN	4 980	6 000	1.75	2.15	6.40	2.20	2.70	9.80	0.000070	0.000110
MS2N04-COBNN	3 230	6 000	2.80	3.50	13.00	1.78	2.24	9.70	0.000110	0.000160
MS2N04-COBTN	3 900	6 000	2.80	3.50	13.00	3.11	3.90	17.30	0.000110	0.000160
MS2N04-DOBHN	2 040	4 000	3.85	4.65	19.70	1.61	1.96	9.70	0.000160	0.000200
MS2N04-DOBQN	3 320	6 000	3.85	4.65	19.70	2.86	3.48	17.30	0.000160	0.000200
MS2N05-BOBNN	2 850	6 000	3.75	4.45	11.50	2.29	2.75	8.40	0.000170	0.000280
MS2N05-BOBTN	5 410	6 000	3.75	4.45	11.50	4.55	5.45	16.80	0.000170	0.000280
MS2N05-COBNN	2 990	6 000	6.10	7.15	22.60	3.53	4.16	15.10	0.000290	0.000400
MS2N05-COBTN	4 090	6 000	6.10	7.15	22.60	7.10	8.35	30.20	0.000290	0.000400
MS2N05-DOBHN	2 000	4 000	7.90	9.35	34.00	3.05	3.63	15.15	0.000400	0.000510
MS2N05-DOBRN	3 510	6 000	7.90	9.35	34.00	6.05	7.20	30.30	0.000400	0.000510
MS2N06-B1BNN	3 000	6 000	3.25	3.60	10.20	2.22	2.47	7.80	0.000480	0.000590
MS2N06-COBNN	3 000	6 000	6.00	7.10	17.30	3.75	4.50	12.75	0.000390	0.000500
MS2N06-COBTN	4 020	6 000	6.00	7.10	17.30	7.50	9.00	25.50	0.000390	0.000500
MS2N06-DOBNN	2 960	6 000	9.70	11.90	34.80	6.10	7.55	25.40	0.000650	0.000790
MS2N06-DOBRN	3 800	6 000	9.70	11.90	34.80	7.85	9.75	32.70	0.000650	0.000790
MS2N06-D1BNN	3 000	6 000	9.00	11.10	41.80	5.05	6.25	25.50	0.001400	0.001540
MS2N06-E0BHN	2 000	4 000	13.00	16.30	53.40	5.40	6.80	25.40	0.000890	0.001030
MS2N06-E0BRN	3 120	6 000	13.00	16.30	53.40	10.85	13.70	50.80	0.000890	0.001030
MS2N07-B1BNN	2 920	6 000	7.40	8.20	22.80	4.25	4.74	14.80	0.001970	0.002230
MS2N07-COBNN	2 650	6 000	12.80	16.00	38.80	6.90	8.80	24.80	0.001200	0.001460
MS2N07-COBQN	4 070	6 000	12.80	16.00	38.80	10.10	12.90	36.40	0.001200	0.001460
MS2N07-C1BNN	3 020	6 000	11.50	14.50	46.00	6.60	8.35	29.50	0.003050	0.003310
MS2N07-C1BRN	3 610	6 000	11.50	14.50	46.00	9.55	12.10	42.70	0.003050	0.003310
MS2N07-DOBHN	2 000	4 000	22.00	28.20	79.70	8.55	11.10	36.40	0.002100	0.002510
MS2N07-DOBNN	2 940	6 000	22.00	28.20	79.70	11.55	15.00	49.50	0.002100	0.002510
MS2N07-DOBRN	3 020	6 000	22.00	28.20	79.70	17.10	22.30	72.70	0.002100	0.002510
MS2N07-D1BHN	2 000	4 000	18.90	23.80	92.50	7.80	9.90	42.70	0.005290	0.005700
MS2N07-D1BNN	3 000	6 000	18.90	23.80	92.50	9.90	12.50	54.10	0.005290	0.005700

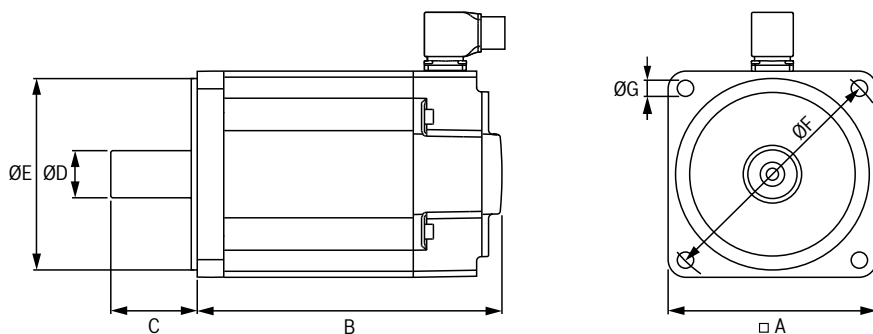

Dimensions																			
Type	A	B				C	ØD	ØE	ØF	ØG	Mass								
		Flange	Frame length	Additional length							Shaft length	Shaft	Centering collar	Hole circle	Mounting hole	Without brake	With brake		
				Encoder performance														Holding brake	
				A	B/C/H														D
mm	mm	mm	mm	mm	mm	mm	mm	mm	kg	kg									
MS2N03-B0BYN	58	148	+15	+0	+29.0	20	9	40	63	4.5	1.4	1.8							
MS2N03-D0BYN	58	188	+15	+0	+29.0	23	11	40	63	4.5	2.0	2.4							
MS2N04-B0BNN	82	147	+15	+0	+32.5	30	14	50	95	6.6	2.7	3.4							
MS2N04-B0BTN	82	147	+15	+0	+32.5	30	14	50	95	6.6	2.7	3.4							
MS2N04-C0BNN	82	179	+15	+0	+32.5	30	14	50	95	6.6	3.7	4.4							
MS2N04-C0BTN	82	179	+15	+0	+32.5	30	14	50	95	6.6	3.7	4.4							
MS2N04-D0BHN	82	211	+15	+0	+32.5	30	14	50	95	6.6	4.7	5.4							
MS2N04-D0BQN	82	211	+15	+0	+32.5	30	14	50	95	6.6	4.7	5.4							
MS2N05-B0BNN	98	170	+18	+0	+30.0	40	19	95	115	9.0	4.0	5.1							
MS2N05-B0BTN	98	170	+18	+0	+30.0	40	19	95	115	9.0	4.0	5.1							
MS2N05-C0BNN	98	206	+18	+0	+30.0	40	19	95	115	9.0	5.9	7.0							
MS2N05-C0BTN	98	206	+18	+0	+30.0	40	19	95	115	9.0	5.9	7.0							
MS2N05-D0BHN	98	242	+18	+0	+30.0	40	19	95	115	9.0	7.3	8.4							
MS2N05-D0BRN	98	242	+18	+0	+30.0	40	19	95	115	9.0	7.3	8.4							
MS2N06-B1BNN	116	164	+0	+18	+37.0	50	24	95	130	9.0	5.1	6.2							
MS2N06-C0BNN	116	184	+0	+18	+37.0	50	24	95	130	9.0	6.4	7.4							
MS2N06-C0BTN	116	184	+0	+18	+37.0	50	24	95	130	9.0	6.4	7.4							
MS2N06-D0BNN	116	224	+0	+18	+37.0	50	24	95	130	9.0	9.0	10.5							
MS2N06-D0BRN	116	224	+0	+18	+37.0	50	24	95	130	9.0	9.0	10.5							
MS2N06-D1BNN	116	224	+0	+18	+37.0	50	24	95	130	9.0	9.0	10.5							
MS2N06-E0BHN	116	264	+0	+18	+37.0	50	24	95	130	9.0	11.5	13.0							
MS2N06-E0BRN	116	264	+0	+18	+37.0	50	24	95	130	9.0	11.5	13.0							
MS2N07-B1BNN	140	176	+0	+16	+54.0	58	32	130	165	11.0	9.5	11.5							
MS2N07-C0BNN	140	205	+0	+16	+54.0	58	32	130	165	11.0	12.0	14.0							
MS2N07-C0BQN	140	205	+0	+16	+54.0	58	32	130	165	11.0	12.0	14.0							
MS2N07-C1BNN	140	205	+0	+16	+54.0	58	32	130	165	11.0	12.0	14.0							
MS2N07-C1BRN	140	205	+0	+16	+54.0	58	32	130	165	11.0	12.0	14.0							
MS2N07-D0BHN	140	263	+0	+16	+54.0	58	32	130	165	11.0	17.5	20.0							
MS2N07-D0BNN	140	263	+0	+16	+54.0	58	32	130	165	11.0	17.5	20.0							
MS2N07-D0BRN	140	263	+0	+16	+54.0	58	32	130	165	11.0	17.5	20.0							
MS2N07-D1BHN	140	263	+0	+16	+54.0	58	32	130	165	11.0	17.5	20.0							
MS2N07-D1BNN	140	263	+0	+16	+54.0	58	32	130	165	11.0	17.5	20.0							

MS2N Self-cooling

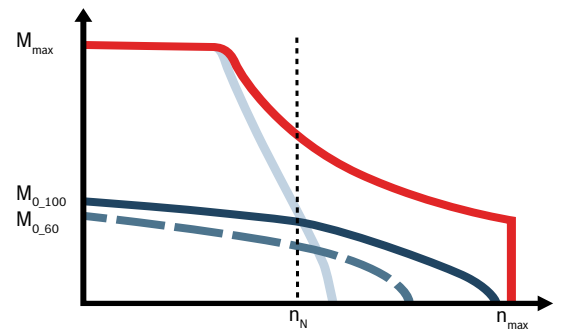

■ For more information, please visit: www.boschrexroth.com/cat-ms2n

Technical specifications										
Type	Rated speed	Maximum speed	Standstill torque		Maximum torque	Continuous standstill current		Maximum current	Moment of inertia	
			60 K	100 K		60 K	100 K		Without brake	With Brake
	n_N	n_{max}	M_{0_60}	M_{0_100}	M_{max}	I_{0_60}	I_{0_100}	I_{max}	$J_{R. w/o br.}$	$J_{R. w. br.}$
	min ⁻¹	min ⁻¹	Nm	Nm	Nm	A	A	A	kg·m ²	kg·m ²
MS2N07-E0BHN	1 940	4 000	29.20	38.20	119.50	10.35	13.70	49.50	0.003000	0.003410
MS2N07-E0BNN	2 600	6 000	29.20	38.20	119.50	15.10	20.00	72.70	0.003000	0.003410
MS2N07-E0BQN	2 570	6 000	29.20	38.20	119.50	19.10	25.30	92.30	0.003000	0.003410
MS2N07-E1BHN	2 000	4 000	25.80	32.20	140.00	9.00	11.30	54.10	0.007520	0.007930
MS2N07-E1BNN	2 500	6 000	25.80	32.20	140.00	14.10	17.70	85.40	0.007520	0.007930
MS2N10-B1BQN	3 520	6 000	15.60	16.70	41.30	13.10	14.20	42.00	0.005200	0.005610
MS2N10-C0BHN	2 000	4 000	30.20	34.00	76.80	12.60	14.50	38.50	0.004800	0.006270
MS2N10-C0BNN	2 880	6 000	30.20	34.00	76.80	16.80	19.30	51.30	0.004800	0.006270
MS2N10-C1BHN	2 000	4 000	27.30	31.00	86.50	11.10	12.75	40.90	0.009200	0.010670
MS2N10-C1BNN	3 090	6 000	27.30	31.00	86.50	16.50	19.00	60.80	0.009200	0.010670
MS2N10-D0BHN	2 000	4 000	51.00	60.50	155.00	19.10	23.10	70.00	0.008100	0.009570
MS2N10-D0BNN	2 600	6 000	51.00	60.50	155.00	28.20	34.10	102.50	0.008100	0.009570
MS2N10-D1BFN	1 600	3 000	47.20	56.00	174.00	14.30	17.20	60.70	0.017100	0.018570
MS2N10-D1BNN	2 460	6 000	47.20	56.00	174.00	28.60	34.30	121.50	0.017100	0.018570
MS2N10-E0BHN	2 000	4 000	67.70	82.50	234.00	25.00	31.00	102.50	0.011400	0.014100
MS2N10-E0BNN	2 120	6 000	67.70	82.50	234.00	34.50	42.80	140.00	0.011400	0.014100
MS2N10-E1BFN	1 500	3 000	64.00	76.00	266.00	17.10	20.50	81.00	0.025000	0.027700
MS2N10-E1BNN	1 970	6 000	64.00	76.00	266.00	34.20	41.00	162.00	0.025000	0.027700
MS2N10-F0BDN	1 000	2 000	85.00	103.00	313.00	15.80	19.50	70.00	0.014700	0.017400
MS2N10-F0BHN	2 000	4 000	85.00	103.00	313.00	32.00	39.40	140.00	0.014700	0.017400
MS2N10-F1BDN	1 000	2 000	79.50	96.50	360.00	15.90	19.50	81.00	0.032900	0.035600
MS2N10-F1BHN	2 000	4 000	79.50	96.50	360.00	31.80	38.90	162.00	0.032900	0.035600

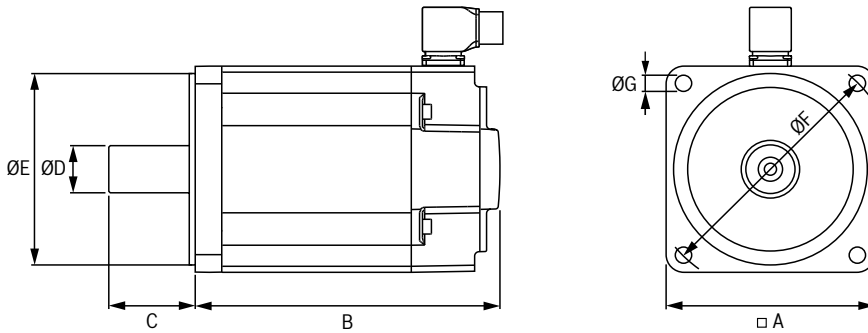
Dimensions

Type	A	B				C	ØD	ØE	ØF	ØG	Mass		
	Flange	Frame length	Additional length			Shaft length	Shaft	Centering collar	Hole circle	Mounting hole	Without brake	With brake	
			Encoder performance										Holding brake
			A	B/C/H	D								
mm	mm	mm	mm	mm	mm	mm	mm	mm	kg	kg			
MS2N07-E0BHN	140	321	+0	+16	+54.0	58	32	130	165	11.0	23.0	26.0	
MS2N07-E0BNN	140	321	+0	+16	+54.0	58	32	130	165	11.0	23.0	26.0	
MS2N07-E0BQN	140	321	+0	+16	+54.0	58	32	130	165	11.0	23.0	26.0	
MS2N07-E1BHN	140	321	+0	+16	+54.0	58	32	130	165	11.0	23.0	26.0	
MS2N07-E1BNN	140	321	+0	+16	+54.0	58	32	130	165	11.0	23.0	26.0	
MS2N10-B1BQN	196	194	+0	+0	+51.0	80	38	180	215	14.0	17.5	21.0	
MS2N10-C0BHN	196	238	+0	+0	+60.0	80	38	180	215	14.0	23.5	28.5	
MS2N10-C0BNN	196	238	+0	+0	+60.0	80	38	180	215	14.0	23.5	28.5	
MS2N10-C1BHN	196	238	+0	+0	+60.0	80	38	180	215	14.0	24.0	29.0	
MS2N10-C1BNN	196	238	+0	+0	+60.0	80	38	180	215	14.0	24.0	29.0	
MS2N10-D0BHN	196	296	+0	+0	+60.0	80	38	180	215	14.0	34.0	39.0	
MS2N10-D0BNN	196	296	+0	+0	+60.0	80	38	180	215	14.0	34.0	39.0	
MS2N10-D1BFN	196	296	+0	+0	+60.0	80	38	180	215	14.0	36.0	41.0	
MS2N10-D1BNN	196	296	+0	+0	+60.0	80	38	180	215	14.0	36.0	41.0	
MS2N10-E0BHN	196	354	+0	+0	+60.0	80	38	180	215	14.0	45.0	52.0	
MS2N10-E0BNN	196	354	+0	+0	+60.0	80	38	180	215	14.0	45.0	52.0	
MS2N10-E1BFN	196	354	+0	+0	+60.0	80	38	180	215	14.0	47.0	54.0	
MS2N10-E1BNN	196	354	+0	+0	+60.0	80	38	180	215	14.0	47.0	54.0	
MS2N10-F0BDN	196	412	+0	+0	+60.0	80	38	180	215	14.0	55.0	62.0	
MS2N10-F0BHN	196	412	+0	+0	+60.0	80	38	180	215	14.0	55.0	62.0	
MS2N10-F1BDN	196	412	+0	+0	+60.0	80	38	180	215	14.0	59.0	66.0	
MS2N10-F1BHN	196	412	+0	+0	+60.0	80	38	180	215	14.0	59.0	66.0	

MS2N

Forced ventilated

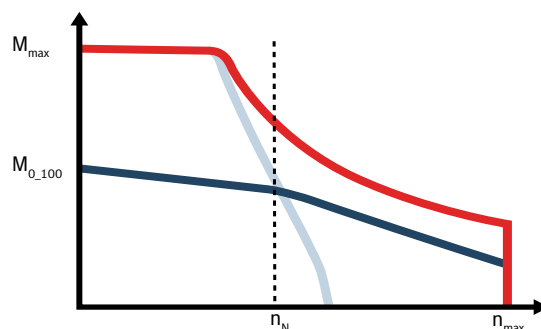

■ For more information, please visit: www.boschrexroth.com/cat-ms2n

Technical specifications											
Type	Rated speed	Maximum speed		Standstill torque		Maximum torque		Continuous standstill current		Moment of inertia	
										Without brake	With brake
	n_N	n_{max}	M_{0_100}	M_{max}	I_{0_100}	I_{max}	$J_{R. w/o br.}$	$J_{R. w. br.}$			
	min ⁻¹	min ⁻¹	Nm	Nm	A	A	kg·m ²	kg·m ²			
MS2N07-COBNA/B	2 490	6 000	19.8	38.8	11.0	24.8	0.00120	0.00146			
MS2N07-COBQA/B	3 900	6 000	19.8	38.8	15.8	36.4	0.00120	0.00146			
MS2N07-C1BNA/B	3 000	6 000	18.0	46.0	10.4	29.5	0.00305	0.00331			
MS2N07-C1BRA/B	4 100	6 000	18.0	46.0	14.9	42.7	0.00305	0.00331			
MS2N07-DOBHA/B	1 870	4 000	35.5	79.7	14.1	36.4	0.00210	0.00251			
MS2N07-DOBNA/B	2 660	6 000	35.5	79.7	19.1	49.5	0.00210	0.00251			
MS2N07-DOBRA/B	3 650	6 000	35.5	79.7	28.2	72.7	0.00210	0.00251			
MS2N07-D1BHA/B	2 000	4 000	31.0	92.5	12.9	42.7	0.00529	0.00570			
MS2N07-D1BNA/B	2 870	6 000	31.0	92.5	16.3	54.1	0.00529	0.00570			
MS2N07-E0BHA/B	1 700	4 000	49.5	119.5	17.9	49.5	0.00300	0.00341			
MS2N07-E0BNA/B	2 730	6 000	49.5	119.5	26.2	72.7	0.00300	0.00341			
MS2N07-E0BQA/B	3 300	6 000	49.5	119.5	33.3	92.3	0.00300	0.00341			
MS2N07-E1BHA/B	1 900	4 000	43.5	140.0	15.2	54.1	0.00752	0.00793			
MS2N07-E1BNA/B	3 100	6 000	43.5	140.0	23.9	85.4	0.00752	0.00793			
MS2N10-COBHA/B	1 820	4 000	43.2	76.8	18.8	38.5	0.00480	0.00627			
MS2N10-COBNA/B	2 610	6 000	43.2	76.8	25.1	51.3	0.00480	0.00627			
MS2N10-C1BHA/B	2 000	4 000	40.0	86.5	16.7	40.9	0.00920	0.01067			
MS2N10-C1BNA/B	3 000	6 000	40.0	86.5	24.7	60.8	0.00920	0.01067			
MS2N10-DOBHA/B	1 800	4 000	82.4	155.0	32.4	70.0	0.00810	0.00957			
MS2N10-DOBNA/B	2 870	6 000	82.4	155.0	48.0	102.5	0.00810	0.00957			
MS2N10-D1BFA/B	1 500	3 000	78.0	174.0	24.2	60.7	0.01710	0.01857			
MS2N10-D1BNA/B	3 000	6 000	78.0	174.0	48.5	121.5	0.01710	0.01857			
MS2N10-E0BHA/B	1 800	4 000	119.0	234.0	46.1	102.5	0.01140	0.01410			
MS2N10-E0BNA/B	2 660	6 000	119.0	234.0	62.9	140.0	0.01140	0.01410			
MS2N10-E1BFA/B	1 350	3 000	113.0	266.0	30.8	81.0	0.02500	0.02770			
MS2N10-E1BNA/B	2 950	6 000	113.0	266.0	61.7	162.0	0.02500	0.02770			
MS2N10-F0BDA/B	900	2 000	148.5	313.0	28.8	70.0	0.01470	0.01740			
MS2N10-F0BHA/B	1 950	4 000	148.5	313.0	58.6	140.0	0.01470	0.01740			
MS2N10-F1BDA/B	1 000	2 000	145.0	360.0	29.5	81.0	0.03290	0.03560			
MS2N10-F1BHA/B	2 000	4 000	145.0	360.0	58.6	162.0	0.03290	0.03560			

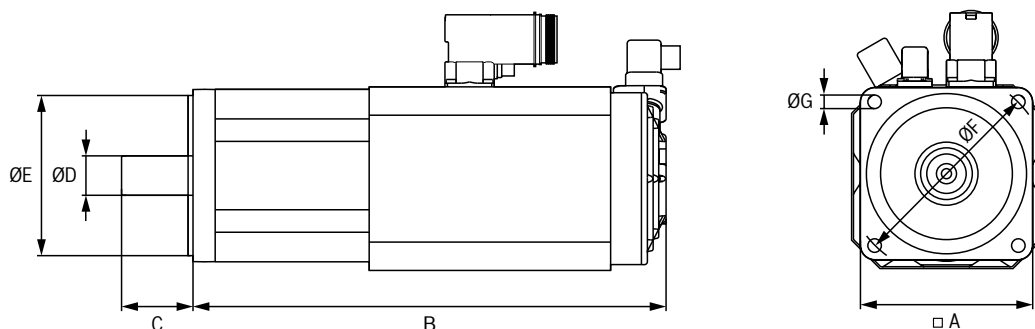

Dimensions										
Type	A	B		C	ØD	ØE	ØF	ØG	Mass	
	Flange	Frame length	Additional length of the holding brake	Shaft length	Shaft	Centering collar	Hole circle	Mounting hole	Without brake	With brake
	mm	mm	mm	mm	mm	mm	mm	mm	kg	kg
MS2N07-C0BNA/B	140	326	+54	58	32	130	165	11	14.5	16.5
MS2N07-C0BQA/B	140	326	+54	58	32	130	165	11	15.0	17.0
MS2N07-C1BNA/B	140	326	+54	58	32	130	165	11	14.5	16.5
MS2N07-C1BRA/B	140	326	+54	58	32	130	165	11	14.5	16.5
MS2N07-D0BHA/B	140	384	+54	58	32	130	165	11	20.0	22.5
MS2N07-D0BNA/B	140	384	+54	58	32	130	165	11	20.0	22.5
MS2N07-D0BRA/B	140	384	+54	58	32	130	165	11	20.0	22.5
MS2N07-D1BHA/B	140	384	+54	58	32	130	165	11	21.0	23.5
MS2N07-D1BNA/B	140	384	+54	58	32	130	165	11	21.0	23.5
MS2N07-E0BHA/B	140	442	+54	58	32	130	165	11	26.0	29.0
MS2N07-E0BNA/B	140	442	+54	58	32	130	165	11	26.0	29.0
MS2N07-E0BQA/B	140	442	+54	58	32	130	165	11	26.0	29.0
MS2N07-E1BHA/B	140	442	+54	58	32	130	165	11	26.0	29.0
MS2N07-E1BNA/B	140	442	+54	58	32	130	165	11	26.0	29.0
MS2N10-C0BHA/B	196	336	+60	80	38	180	215	14	24.5	29.5
MS2N10-C0BNA/B	196	336	+60	80	38	180	215	14	24.5	29.5
MS2N10-C1BHA/B	196	336	+60	80	38	180	215	14	25.0	30.0
MS2N10-C1BNA/B	196	336	+60	80	38	180	215	14	25.0	30.0
MS2N10-D0BHA/B	196	394	+60	80	38	180	215	14	35.0	40.0
MS2N10-D0BNA/B	196	394	+60	80	38	180	215	14	35.0	40.0
MS2N10-D1BFA/B	196	394	+60	80	38	180	215	14	37.0	42.0
MS2N10-D1BNA/B	196	394	+60	80	38	180	215	14	37.0	42.0
MS2N10-E0BHA/B	196	452	+60	80	38	180	215	14	46.0	53.0
MS2N10-E0BNA/B	196	452	+60	80	38	180	215	14	46.0	53.0
MS2N10-E1BFA/B	196	452	+60	80	38	180	215	14	48.0	55.0
MS2N10-E1BNA/B	196	452	+60	80	38	180	215	14	48.0	55.0
MS2N10-F0BDA/B	196	510	+60	80	38	180	215	14	56.0	63.0
MS2N10-F0BHA/B	196	510	+60	80	38	180	215	14	56.0	63.0
MS2N10-F1BDA/B	196	510	+60	80	38	180	215	14	60.0	67.0
MS2N10-F1BHA/B	196	510	+60	80	38	180	215	14	60.0	67.0

MS2N

Water cooling

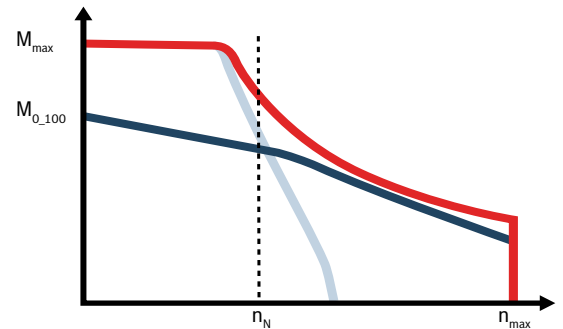

■ For more information, please visit: www.boschrexroth.com/cat-ms2n

Technical specifications									
Type	Rated speed	Maximum speed	Standstill torque	Maximum torque	Continuous standstill current	Maximum current	Moment of inertia		
			100 K				Without brake	With brake	
	n_N	n_{max}	$M_{0.100}$	M_{max}	$I_{0.100}$	I_{max}	$J_{R. w/o br.}$	$J_{R. w. br.}$	
	min ⁻¹	min ⁻¹	Nm	Nm	A	A	kg·m ²	kg·m ²	
MS2N07-COBNL	2 100	6 000	26.6	38.8	15.3	24.8	0.00120	0.00146	
MS2N07-COBQL	3 360	6 000	26.6	38.8	22.3	36.4	0.00120	0.00146	
MS2N07-C1BNL	2 610	6 000	25.0	46.0	14.2	29.5	0.00305	0.00331	
MS2N07-C1BRL	4 090	6 000	25.0	46.0	20.8	42.7	0.00305	0.00331	
MS2N07-DOBHL	1 550	4 000	55.0	79.7	22.8	36.4	0.00210	0.00251	
MS2N07-DOBNL	2 100	6 000	55.0	79.7	31.0	49.5	0.00210	0.00251	
MS2N07-DOBRL	3 650	6 000	55.0	79.7	45.8	72.7	0.00210	0.00251	
MS2N07-D1BHL	1 850	4 000	50.5	92.5	21.1	42.7	0.00529	0.00570	
MS2N07-D1BNL	2 450	6 000	50.5	92.5	26.7	54.1	0.00529	0.00570	
MS2N07-E0BHL	1 400	4 000	83.0	119.5	31.5	49.5	0.00300	0.00341	
MS2N07-E0BNL	2 200	6 000	83.0	119.5	46.0	72.7	0.00300	0.00341	
MS2N07-E0BQL	3 000	6 000	83.0	119.5	58.3	92.3	0.00300	0.00341	
MS2N07-E1BHL	1 550	4 000	76.5	140.0	26.6	54.1	0.00752	0.00793	
MS2N07-E1BNL	2 700	6 000	76.5	140.0	42.1	85.4	0.00752	0.00793	
MS2N10-COBHL	1 720	4 000	51.7	76.8	23.1	38.5	0.00480	0.00627	
MS2N10-COBNL	2 310	6 000	51.7	76.8	30.8	51.3	0.00480	0.00627	
MS2N10-C1BHL	1 900	4 000	48.0	86.5	19.6	40.9	0.00920	0.01067	
MS2N10-C1BNL	2 900	6 000	48.0	86.5	29.9	60.8	0.00920	0.01067	
MS2N10-DOBHL	1 550	4 000	107.5	155.0	43.7	70.0	0.00810	0.00957	
MS2N10-DOBNL	2 420	6 000	107.5	155.0	64.7	102.5	0.00810	0.00957	
MS2N10-D1BFL	1 350	3 000	101.0	174.0	30.8	60.7	0.01710	0.01857	
MS2N10-D1BNL	3 000	6 000	101.0	174.0	63.3	121.5	0.01710	0.01857	
MS2N10-E0BHL	1 540	4 000	162.0	234.0	65.4	102.5	0.01140	0.01410	
MS2N10-E0BNL	2 220	6 000	162.0	234.0	90.0	140.0	0.01140	0.01410	
MS2N10-E1BFL	1 200	3 000	159.0	266.0	44.2	81.0	0.02500	0.02770	
MS2N10-E1BNL	2 750	6 000	159.0	266.0	88.0	162.0	0.02500	0.02770	
MS2N10-F0BDL	750	2 000	214.0	313.0	43.3	70.0	0.01470	0.01740	
MS2N10-F0BHL	1 650	4 000	214.0	313.0	87.5	140.0	0.01470	0.01740	
MS2N10-F1BDL	925	2 000	209.0	360.0	42.8	81.0	0.03290	0.03560	
MS2N10-F1BHL	1 930	4 000	209.0	360.0	86.0	162.0	0.03290	0.03560	

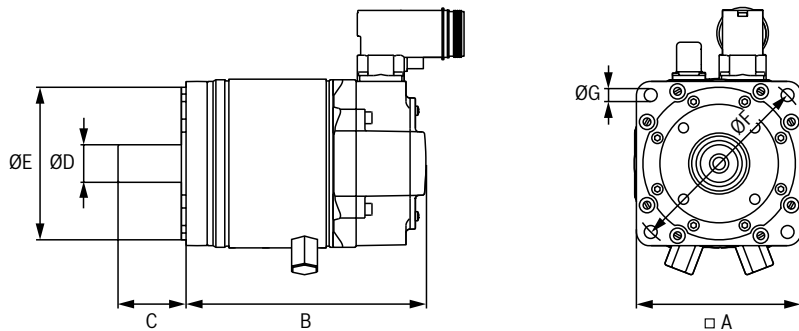

Dimensions											
Type	A	B			C	ØD	ØE	ØF	ØG	Mass	
	Flange	Frame length	Additional length		Shaft length	Shaft	Centering collar	Hole circle	Mounting hole	Without brake	With brake
			Encoder performance								
		A, B, C	D	mm						mm	mm
MS2N07-C0BNL	140	205	+16	+54	58	32	130	165	11	14.0	16.0
MS2N07-C0BQL	140	205	+16	+54	58	32	130	165	11	14.0	16.0
MS2N07-C1BNL	140	205	+16	+54	58	32	130	165	11	14.0	16.0
MS2N07-C1BRL	140	205	+16	+54	58	32	130	165	11	13.5	15.5
MS2N07-D0BHL	140	263	+16	+54	58	32	130	165	11	19.5	22.0
MS2N07-D0BNL	140	263	+16	+54	58	32	130	165	11	19.5	22.0
MS2N07-D0BRL	140	263	+16	+54	58	32	130	165	11	19.5	22.0
MS2N07-D1BHL	140	263	+16	+54	58	32	130	165	11	20.0	23.0
MS2N07-D1BNL	140	263	+16	+54	58	32	130	165	11	20.0	23.0
MS2N07-E0BHL	140	321	+16	+54	58	32	130	165	11	26.0	29.0
MS2N07-E0BNL	140	321	+16	+54	58	32	130	165	11	26.0	29.0
MS2N07-E0BQL	140	321	+16	+54	58	32	130	165	11	26.0	29.0
MS2N07-E1BHL	140	321	+16	+54	58	32	130	165	11	26.5	29.5
MS2N07-E1BNL	140	321	+16	+54	58	32	130	165	11	26.5	29.5
MS2N10-C0BHL	196	238	+0	+60	80	38	180	215	14	29.0	34.0
MS2N10-C0BNL	196	238	+0	+60	80	38	180	215	14	29.0	34.0
MS2N10-C1BHL	196	238	+0	+60	80	38	180	215	14	28.0	33.0
MS2N10-C1BNL	196	238	+0	+60	80	38	180	215	14	28.0	33.0
MS2N10-D0BHL	196	296	+0	+60	80	38	180	215	14	39.0	44.0
MS2N10-D0BNL	196	296	+0	+60	80	38	180	215	14	39.0	44.0
MS2N10-D1BFL	196	296	+0	+60	80	38	180	215	14	39.0	44.0
MS2N10-D1BNL	196	296	+0	+60	80	38	180	215	14	39.0	44.0
MS2N10-E0BHL	196	354	+0	+60	80	38	180	215	14	49.0	56.0
MS2N10-E0BNL	196	354	+0	+60	80	38	180	215	14	49.0	56.0
MS2N10-E1BFL	196	354	+0	+60	80	38	180	215	14	51.0	58.0
MS2N10-E1BNL	196	354	+0	+60	80	38	180	215	14	51.0	58.0
MS2N10-F0BDL	196	412	+0	+60	80	38	180	215	14	59.0	66.0
MS2N10-F0BHL	196	412	+0	+60	80	38	180	215	14	59.0	66.0
MS2N10-F1BDL	196	412	+0	+60	80	38	180	215	14	63.0	70.0
MS2N10-F1BHL	196	412	+0	+60	80	38	180	215	14	63.0	70.0

Synchronous servo motor



MS2E



Practical single-cable connection, more torque and reliable encoder technology: The new generation of MS2E motors offers maximum dynamism and safety in ATEX applications up to equipment group II and equipment category 3 for dust and gas. The self-cooled motors of this series offer overlapping torque ranges with high maximum torques in five sizes. With safe high-resolution single or multiturn encoders and optional holding brake or keyway, they are ideally suited for tailor-made drive solutions in all hazardous areas.

- ▶ **Maximum torque (M_{max}) up to 119 Nm**
- ▶ **Maximum speed (n_{max}) up to 9 000 min⁻¹**
- ▶ **ATEX Gr. II, cat. 3G/3D**
- ▶ **Safe single or multi-turn encoders in SIL2, PL d**
- ▶ **With and without holding brake**
- ▶ **Single cable connection up to 75 m cable length**

ATEX marking

MS2E..	 II 3G Ex ec IIB T155 °C (T3) Gc X
	 II 3D Ex tc IIIC T155 °C Dc IP6X X

Type code	
MS2E05-C 0 BT N-C S S K 0-N N N N-NN	
Frame size 03, 04, 05, 06, 07	Other version N = None
Frame length B, C, D, E	Coating N = Standard
Rotor inertia 0 = Low inertia	Design N = IM B5/IM 3001, sensor PT1000
Winding BN, CN = 3 000 min ⁻¹ BQ, CQ = 4 000 min ⁻¹ BR, CR = 4 500 min ⁻¹ BT = 6 000 min ⁻¹ BY = 9 000 min ⁻¹	Bearing N = Standard
Type of cooling N = Self-cooling	Flange accuracy N = Standard
Encoder performance C = ADVANCED: digital 20-bit, ACURO®link, SIL2	Holding brake 0 = Without holding brake 1, 2 = With holding brake
Encoder design S = Single-turn, 1 rotation absolute M = Multi-turn, 4 096 rotations absolute	Shaft G = Smooth, with shaft seal ring K = Keyway, with shaft seal ring
	Electrical connection S = Single cable connection M23, rotatable

Available options and technical specifications: see project planning instructions: www.boschrexroth.com/cat-ms2e

MS2E

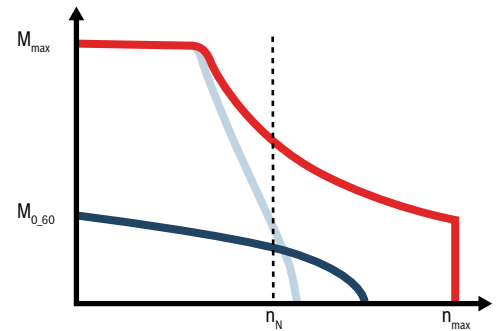

■ For more information, please visit: www.boschrexroth.com/cat-ms2e

Technical specifications									
Type	Rated speed	Maximum speed	Standstill torque	Maximum torque	Continuous standstill current	Maximum current	Moment of inertia		
	n_N	n_{max}	$M_{0,60}$	M_{max}	$I_{0,60}$	I_{max}	Without brake	With brake	
	min ⁻¹	min ⁻¹	Nm	Nm	A	A	kg·m ²	kg·m ²	
MS2E03-B0BYN	5 760	9 000	0.73	3.75	1.31	7.25	0.000023	0.000030	
MS2E03-D0BYN	3 930	9 000	1.15	7.40	2.07	14.50	0.000037	0.000044	
MS2E04-B0BNN	3 000	6 000	1.75	6.40	1.11	4.90	0.000070	0.000110	
MS2E04-B0BTN	4 330	6 000	1.75	6.40	2.20	9.80	0.000070	0.000110	
MS2E04-C0BNN	3 230	6 000	2.80	13.00	1.78	9.70	0.000110	0.000160	
MS2E04-C0BTN	2 965	6 000	2.80	13.00	3.11	17.30	0.000110	0.000160	
MS2E05-B0BTN	4 390	6 000	3.75	11.50	4.55	16.80	0.000170	0.000280	
MS2E05-C0BTN	3 130	6 000	6.10	22.60	7.10	30.20	0.000290	0.000400	
MS2E05-D0BRN	2 915	6 000	7.90	34.00	6.05	30.30	0.000400	0.000510	
MS2E06-C0BNN	3 000	6 000	6.00	17.30	3.75	12.75	0.000390	0.000500	
MS2E06-D0BNN	2 900	6 000	9.70	34.80	6.10	25.40	0.000650	0.000790	
MS2E06-D0BRN	2 870	6 000	9.70	34.80	7.85	32.70	0.000650	0.000790	
MS2E06-E0BRN	2 110	6 000	13.00	53.40	10.85	50.80	0.000890	0.001030	
MS2E07-C0BNN	2 650	6 000	12.80	38.80	6.90	24.80	0.001200	0.001460	
MS2E07-C0BQN	3 100	6 000	12.80	38.80	10.10	36.40	0.001200	0.001460	
MS2E07-D0BNN	2 215	6 000	22.00	79.70	11.55	49.50	0.002100	0.002510	
MS2E07-D0CRN	2 180	6 000	19.90	79.70	15.50	72.70	0.002100	0.002510	
MS2E07-E0CNN	1 890	6 000	29.20	119.50	15.10	72.70	0.003000	0.003410	
MS2E07-E0CQN	1 750	6 000	23.60	119.50	15.50	92.30	0.003000	0.003410	

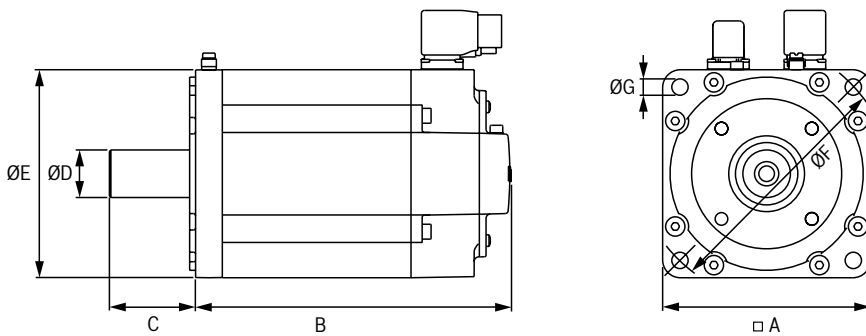
Dimensions

Type	A		B		C	ØD	ØE	ØF	ØG	Mass	
	Flange	Frame length	Additional length of the holding brake	Shaft length	Shaft	Centering collar	Hole circle	Mounting hole	Without brake	With brake	
	mm	mm	mm	mm	mm	mm	mm	mm	kg	kg	
MS2E03-B0BYN	58	163	+29.0	20	9	40	63	4.5	1.4	1.8	
MS2E03-D0BYN	58	203	+29.0	23	11	40	63	4.5	2.0	2.4	
MS2E04-B0BNN	82	166	+32.5	30	14	50	95	6.6	2.7	3.4	
MS2E04-B0BTN	82	166	+32.5	30	14	50	95	6.6	2.7	3.4	
MS2E04-C0BNN	82	198	+32.5	30	14	50	95	6.6	3.7	4.4	
MS2E04-C0BTN	82	198	+32.5	30	14	50	95	6.6	3.7	4.4	
MS2E05-B0BTN	98	188	+30.0	40	19	95	115	9.0	4.0	5.1	
MS2E05-C0BTN	98	224	+30.0	40	19	95	115	9.0	5.9	7.0	
MS2E05-D0BRN	98	260	+30.0	40	19	95	115	9.0	7.3	8.4	
MS2E06-C0BNN	116	189	+37.0	50	24	95	130	9.0	6.4	7.4	
MS2E06-D0BNN	116	229	+37.0	50	24	95	130	9.0	9.0	10.5	
MS2E06-D0BRN	116	229	+37.0	50	24	95	130	9.0	9.0	10.5	
MS2E06-E0BRN	116	269	+37.0	50	24	95	130	9.0	11.5	13.0	
MS2E07-C0BNN	140	205	+54.0	58	32	130	165	11.0	12.0	14.0	
MS2E07-C0BQN	140	205	+54.0	58	32	130	165	11.0	12.0	14.0	
MS2E07-D0BNN	140	263	+54.0	58	32	130	165	11.0	17.5	20.0	
MS2E07-D0CRN	140	263	+54.0	58	32	130	165	11.0	17.5	20.0	
MS2N07-E0CNN	140	321	+54.0	58	32	130	165	11.0	23.0	26.0	
MS2E07-E0CQN	140	321	+54.0	58	32	130	165	11.0	23.0	26.0	

Synchronous servo motor

MKE



The motors of the MKE series are specially designed for use in production systems where an explosive mixture of air and flammable gases, vapors, mists or dusts can occur. With a flameproof encapsulation, the MKE motors are suitable for use in ATEX applications up to device group II and device category 2 for dust and gas. The MKE motors according to American standards have been certified directly by UL for use according to UL674. Various motor sizes with flameproof encapsulation are available within the wide range with high maximum torques and maximum speeds. We also supply these motors with many options regarding encoder systems, holding brake, keyway and in single or multiturn design.

- ▶ **Maximum torque (M_{max}) up to 187 Nm**
- ▶ **Maximum speed (n_{max}) up to 9 000 min⁻¹**
- ▶ **Encoder performance: STANDARD or HIGH**
- ▶ **Safe single or multi-turn encoders in SIL2 PLd**
- ▶ **Pressure-resistant encapsulation**
- ▶ **Explosion protection in accordance with ATEX and UL/CSA**

ATEX marking

MKE with enclosure version E	

UL/CSA marking

MKE037/047 with enclosure version U	
MKE098/118 with enclosure version U	

Type code	
MKE037B-144-A G 0-B E N N	
<p>Motor</p> <ul style="list-style-type: none"> ▶ Frame size (e.g. "037") ▶ Frame length (e.g. "B") ▶ Winding (e.g. "037") <p>Encoder</p> <ul style="list-style-type: none"> A = Single-turn encoder (Hiperface®), 128 signal periods B = Single-turn encoder (EnDat), 2 048 signal periods C = Multi-turn encoder (Hiperface®), 128 signal periods with 4 096 rotations absolute D = Multi-turn encoder (EnDat), 2 048 signal periods with 4 096 revolutions absolute <p>Shaft</p> <ul style="list-style-type: none"> G = Smooth shaft with shaft seal ring P = Keyway according to DIN 6885-1 and shaft seal 	<p>Cable gland</p> <ul style="list-style-type: none"> 4 = Ø 13.5 ... 15.5 mm 6 = Ø 17.5 ... 19.5 mm N = As per American standard (UL) <p>Enclosure version</p> <ul style="list-style-type: none"> E = As per European standard (ATEX) U = As per American standard (UL) <p>Electrical connection</p> <ul style="list-style-type: none"> A = To the A side B = To the B side L = To the left R = To the right <p>Holding brake</p> <ul style="list-style-type: none"> 0 = Without holding brake 1 = With holding brake

Available options and technical specifications: see project planning instructions: www.boschrexroth.com/cat-mke

MKE

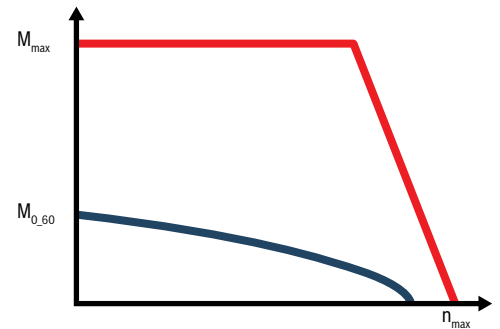

■ For more information, please visit: www.boschrexroth.com/cat-mke

Technical specifications								
Type	Maximum speed	Standstill torque 60K	Maximum torque	Continuous standstill current 60K	Maximum current	Moment of inertia		
						Without brake	With brake	
	$n_{\max}^{1)}$	$M_{0,60}$	M_{\max}	$I_{0,60}$	I_{\max}	$J_{R, w/o br.}$	$J_{R, w. br.}$	
	min ⁻¹	Nm	Nm	A	A	kg·m ²	kg·m ²	
MKE037B-144	9 000	0.9	4.0	3.30	15.00	0.00003	0.00004	
MKE047B-144	7 000	2.7	11.3	5.00	22.60	0.00017	0.00018	
MKE098B-047	4 500	12.0	43.5	9.80	44.30	0.00430	0.00466	
MKE098B-058	5 000	12.0	43.5	12.40	55.90	0.00430	0.00466	
MKE118B-024	4 000	28.0	102.0	15.34	69.10	0.01940	0.02064	
MKE118B-058	4 500	28.0	102.0	28.38	127.63	0.01940	0.02064	
MKE118D-012	2 100	48.0	187.0	13.01	58.55	0.03620	0.03938	
MKE118D-027	3 000	48.0	187.0	22.13	99.63	0.03620	0.03938	
MKE118D-035	3 000	48.0	187.0	29.81	134.33	0.03620	0.03938	

¹⁾ At 750 V DC bus voltage

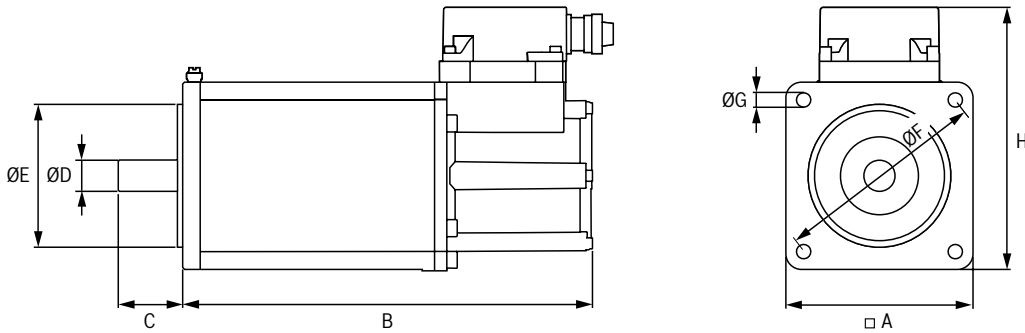
Dimensions

Type	A	B	C	ØD	ØE	ØF	ØG	H	Mass
	Flange	Frame length	Shaft length	Shaft	Centering collar	Hole circle	Mounting hole	Height	
	mm	mm	mm	mm	mm	mm	mm	mm	
MKE037B-144	60	283	20	9	40	70	4.5	123	2.5
MKE047B-144	88	287	30	14	50	100	6.6	146	5.5
MKE098B-047	144	383	50	24	110	165	11.0	202	18.0
MKE098B-058	144	383	50	24	110	165	11.0	202	18.0
MKE118B-024	194	492	60	32	130	215	14.0	205	45.0
MKE118B-058	194	492	60	32	130	215	14.0	205	45.0
MKE118D-012	194	664	60	32	130	215	14.0	205	65.0
MKE118D-027	194	664	60	32	130	215	14.0	205	65.0
MKE118D-035	194	664	60	32	130	215	14.0	205	65.0

Synchronous servo motor

MSM



The maintenance-free MSM motors are available in five sizes with continuous mechanical power ratings of up to 750 W. The high power density with short overall length and minimized flange dimensions enable use in a wide variety of applications. The motors with IP54 degree of protection are equipped with absolute encoders and can be supplied with or without holding brake. They are ideal for operation with IndraDrive Cs drive units with 1 x AC 230 V and 3 x AC 230 V power supply.

- ▶ **Maximum torque (M_{max}) up to 7.1 Nm**
- ▶ **Maximum speed (n_{max}) up to 5 000 min⁻¹**
- ▶ **Multi-turn absolute encoder**
- ▶ **Smooth shaft or keyway**
- ▶ **Cable connection, M17 round plug**

■ For more information, please visit: www.boschrexroth.com/cat-msm

Type code	
MSM019 A-0300-NN-M5-M H 0	
<p>Frame size</p> <p>019 = Flange 38 mm 031 = Flange 60 mm 041 = Flange 80 mm</p> <p>Frame length</p> <p>E.g. "A"</p> <p>Winding</p> <p>0300 = Rated speed 3 000 min⁻¹</p> <p>Type of cooling</p> <p>NN = Natural convection</p> <p>Encoder</p> <p>M5 = Digital multi-turn absolute encoder with encoder resolution of 20 bits per revolution</p>	<p>Holding brake</p> <p>0 = Without holding brake 1 = With holding brake</p> <p>Shaft</p> <p>H = Smooth shaft, without shaft seal ring L = Shaft with keyway, without shaft seal ring</p> <p>Electrical connection</p> <p>M = Cable connection, M17 round plug</p>

Available options and technical specifications: see project planning instructions: www.boschrexroth.com/cat-msm

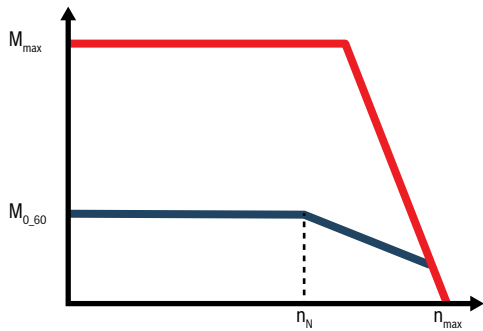
Technical specifications

Type	Maximum speed n_{max}	Standstill torque 60K M_{0_60}	Maximum torque M_{max}	Rated power P_N	Continuous standstill current 60K I_{0_60}	Maximum current I_{max}	Moment of inertia	
							Without brake	With brake
							$J_{R. w/o br.}$	$J_{R. w. br.}$
	min^{-1}	Nm	Nm	kW	A	A	$kg \cdot m^2$	$kg \cdot m^2$
MSM019A	5 000	0.16	0.48	0.05	1.1	3.3	0.0000025	0.0000027
MSM019B	5 000	0.32	0.95	0.10	1.1	3.3	0.0000051	0.0000053
MSM031B	5 000	0.64	1.91	0.20	1.6	4.9	0.0000140	0.0000158
MSM031C	5 000	1.30	3.80	0.40	2.6	7.7	0.0000260	0.0000278
MSM041B	4 500	2.40	7.10	0.75	4.0	12.0	0.0000870	0.0000945

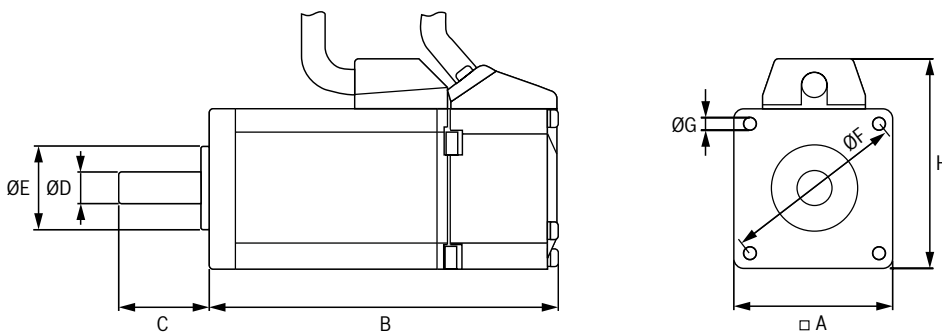
Dimensions

Type	A	B		C	ØD	ØE	ØF	ØG	H	Mass	
	Flange	Frame length	Additional length of the holding brake	Shaft length	Shaft	Centering collar	Hole circle	Mounting hole	Height	Without brake	With brake
	mm	mm	mm	mm	mm	mm	mm	mm	mm	kg	kg
MSM019A	38	72.0	+30.0	25	8	30	45	3.4	51	0.32	0.53
MSM019B	38	92.0	+30.0	25	8	30	45	3.4	51	0.47	0.68
MSM031B	60	79.0	+36.5	30	11	50	70	4.5	73	0.82	1.30
MSM031C	60	98.5	+36.5	30	14	50	70	4.5	73	1.20	1.70
MSM041B	80	112.0	+37.0	35	19	70	90	6.0	93	2.30	3.10

Asynchronous servo motor

MAD



The high power density predestines the MAD motor series for applications in machine tools and printing machines as well as in metal forming. Fine-resolution encoder systems in single-turn or multi-turn design as well as outstanding radial runout ensure maximum machining precision. In addition to options such as keyway and holding brake, these motors are also available with special bearings for high-speed applications or for applications with increased radial loads. The motor degree of protection IP65 includes the blower motor and thus enables use even in rough industrial environments. The service-friendly motor design even allows easy fan replacement while the motor is running – particularly interesting in the printing industry.

- ▶ **Rated power (P_N) up to 93.1 kW**
- ▶ **Maximum speed (n_{max}) up to 11 000 min⁻¹**
- ▶ **Single-turn, multi-turn, absolute and incremental encoders**
- ▶ **High degree of protection IP65, including blower motor**
- ▶ **Service-friendly motor design**
- ▶ **ATEX option with fan cowl**

ATEX marking

MAD with
Encoder S6/M6

 II 2G Ex px IIB T3 Gb

Type code

MAD100C-0100-SA-S2-A H 0-05-N 1

Motor

- ▶ Frame size (e.g. "037")
- ▶ Frame length (e.g. "B")
- ▶ Winding (e.g. "037")

Type of cooling

- SA** = Axial fan
- SL** = Fan cowl

Encoder

- S2** = Single-turn encoder (EnDat), 2 048 signal periods
- M2** = Multi-turn encoder (EnDat), 2 048 signal periods with 4 096 revolutions absolute
- S6¹⁾** = S2 encoder for ATEX
- M6¹⁾** = M2 encoder for ATEX
- C0** = Incremental encoder 2 048 increments

Electrical connection

Plug

- A** = To the A side
- B** = To the B side
- L** = To the left
- R** = To the right

Terminal box, turnable

- E** = To the A side
- H** = To the B side
- G** = To the left
- D** = To the right

Vibration severity

- 1** = A
- 3** = B
- 4** = C

Bearing

- N** = Standard
- A** = A-side fixed bearing
- H** = High-speed
- V** = Heavy duty

Design

- 05** = Flange mounting
- 35** = Flange or foot mounting

Holding brake

- 0** = Without holding brake
- 1** = With releasing holding brake
- 3** = With releasing holding brake, heavy duty
- 5** = With clamping holding brake

Shaft design

- Smooth shaft
- H** = Without shaft seal ring
- G** = With shaft seal ring (IP65)
- F** = With labyrinth seal ring

Keyway

- Q** = Without shaft seal ring
- P** = With shaft seal ring (IP65)
- R** = With labyrinth seal ring

Available options and technical specifications: see project planning instructions: www.boschrexroth.com/cat-mad

¹⁾ Only in connection with type of cooling option fan nozzles SL

MAD

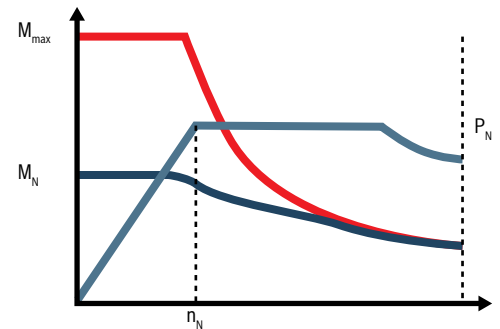

■ For more information, please visit: www.boschrexroth.com/cat-mad

Technical specifications

Type	Rated speed	Maximum speed	Rated torque	Maximum torque	Rated power	Rated current	Maximum current	Moment of inertia
	n_N	n_{max}	M_N	M_{max}	P_N	I_N	I_{max}	Without brake
	min ⁻¹	min ⁻¹	Nm	Nm	kW	A	A	$J_{R. w/o br.}$ kg·m ²
MAD100B-0050	500	3 000	34	75.1	1.80	5.30	10.25	0.0190
MAD100B-0100	1 000	6 000	31	74.7	3.20	8.90	17.96	0.0190
MAD100B-0150	1 500	9 000	30	68.0	4.71	12.90	23.55	0.0190
MAD100B-0200	2 000	11 000	28	66.2	5.90	14.60	28.92	0.0190
MAD100B-0250	2 500	11 000	25	61.5	6.50	16.20	28.32	0.0190
MAD100C-0050	500	3 000	51	112.3	2.70	8.20	15.88	0.0284
MAD100C-0100	1 000	6 000	50	118.8	5.20	13.20	25.39	0.0284
MAD100C-0150	1 500	9 000	48	110.4	7.50	19.70	38.96	0.0284
MAD100C-0200	2 000	11 000	45	105.5	9.40	25.70	47.31	0.0284
MAD100C-0250	2 500	11 000	40	91.0	10.47	27.80	64.30	0.0284
MAD100D-0050	500	3 000	70	153.6	3.70	10.10	19.09	0.0392
MAD100D-0100	1 000	6 000	64	146.5	6.70	19.30	34.30	0.0392
MAD100D-0150	1 500	9 000	59	140.8	9.27	24.70	44.28	0.0392
MAD100D-0200	2 000	11 000	54	129.8	11.30	27.18	52.68	0.0392
MAD100D-0250	2 500	11 000	50	118.7	13.10	32.42	63.95	0.0392
MAD130B-0050	500	3 000	95	208.8	5.00	12.80	25.39	0.0840
MAD130B-0100	1 000	6 000	100	230.0	10.50	26.90	51.30	0.0840
MAD130B-0150	1 500	9 000	85	200.0	13.35	34.90	68.29	0.0840
MAD130B-0200	2 000	10 000	80	187.2	16.80	43.00	80.75	0.0840
MAD130B-0250	2 500	10 000	75	176.5	19.60	47.20	83.35	0.0840
MAD130C-0050	500	3 000	140	307.9	7.30	19.70	35.36	0.1080
MAD130C-0100	1 000	6 000	125	305.0	13.09	36.20	73.80	0.1080
MAD130C-0150	1 500	9 000	117	275.2	18.40	48.90	93.28	0.1080
MAD130C-0200	2 000	10 000	110	252.9	23.00	57.00	106.70	0.1080
MAD130C-0250	2 500	10 000	100	250.0	26.20	62.00	130.31	0.1080
MAD130D-0050	500	3 000	180	395.6	9.40	24.20	47.02	0.1640
MAD130D-0100	1 000	6 000	170	417.8	17.80	43.70	93.43	0.1640
MAD130D-0150	1 500	9 000	155	374.6	24.30	61.50	123.00	0.1640
MAD130D-0200	2 000	10 000	150	340.7	31.40	71.30	137.00	0.1640
MAD130D-0250	2 500	10 000	120	310.0	31.40	72.40	131.31	0.1640

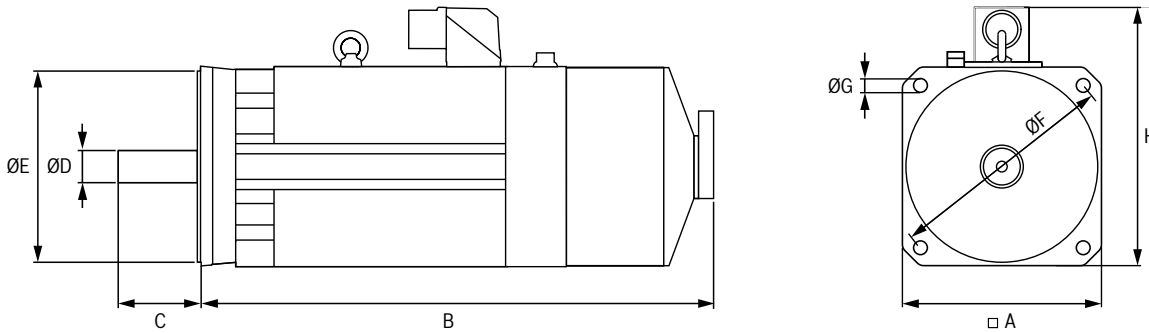

Dimensions

Type	A ¹⁾	B	C	ØD	ØE	ØF	ØG	H ²⁾	Mass
	Flange	Frame length	Shaft length	Shaft	Centering collar	Hole circle	Mounting hole	Height	Without brake
	mm	mm	mm	mm	mm	mm	mm	mm	kg
MAD100B-0050	192	533	60	32	130	215	14	265	43
MAD100B-0100	192	533	60	32	130	215	14	265	43
MAD100B-0150	192	533	60	32	130	215	14	265	43
MAD100B-0200	192	533	60	32	130	215	14	265	43
MAD100B-0250	192	533	60	32	130	215	14	265	43
MAD100C-0050	192	608	60	32	130	215	14	265	59
MAD100C-0100	192	608	60	32	130	215	14	265	59
MAD100C-0150	192	608	60	32	130	215	14	265	59
MAD100C-0200	192	608	60	32	130	215	14	265	59
MAD100C-0250	192	608	60	32	130	215	14	265	59
MAD100D-0050	192	683	60	32	130	215	14	265	72
MAD100D-0100	192	683	60	32	130	215	14	265	72
MAD100D-0150	192	683	60	32	130	215	14	265	72
MAD100D-0200	192	683	60	32	130	215	14	265	72
MAD100D-0250	192	683	60	32	130	215	14	265	72
MAD130B-0050	262	570	110	42	250	300	18	340	105
MAD130B-0100	262	570	110	42	250	300	18	340	105
MAD130B-0150	262	570	110	42	250	300	18	340	105
MAD130B-0200	262	570	110	42	250	300	18	340	105
MAD130B-0250	262	570	110	42	250	300	18	340	105
MAD130C-0050	262	640	110	42	250	300	18	340	124
MAD130C-0100	262	640	110	42	250	300	18	340	124
MAD130C-0150	262	640	110	42	250	300	18	340	124
MAD130C-0200	262	640	110	42	250	300	18	340	124
MAD130C-0250	262	640	110	42	250	300	18	340	124
MAD130D-0050	262	770	110	42	250	300	18	340	165
MAD130D-0100	262	770	110	42	250	300	18	340	165
MAD130D-0150	262	770	110	42	250	300	18	340	165
MAD130D-0200	262	770	110	42	250	300	18	340	165
MAD130D-0250	262	770	110	42	250	300	18	340	165

¹⁾ Enclosure dimension > flange dimension A

²⁾ Motor height H for versions with plug, values for power connection with terminal box may vary and are as follows:
MAD100 = 295 mm; MAD130 = 370 mm; MAD160 = 422 mm

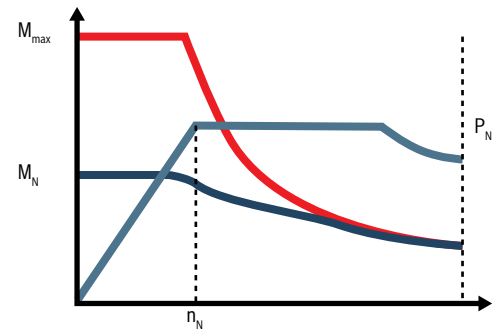
MAD



■ For more information, please visit: www.boschrexroth.com/cat-mad

Technical specifications

Type	Rated speed	Maximum speed	Rated torque	Maximum torque	Rated power	Rated current	Maximum current	Moment of inertia
	n_N	n_{max}	M_N	M_{max}	P_N	I_N	I_{max}	Without brake
	min ⁻¹	min ⁻¹	Nm	Nm	kW	A	A	$J_{R, w/o br.}$ kg·m ²
MAD160B-0050	500	3 000	220	483.9	11.50	26.08	51.67	0.2500
MAD160B-0100	1 000	6 000	200	490.0	20.94	50.80	110.00	0.2500
MAD160B-0150	1 500	8 000	190	440.1	29.80	61.60	132.18	0.2500
MAD160B-0200	2 000	8 000	160	375.3	33.50	75.80	157.40	0.2500
MAD160C-0050	500	3 000	240	528.2	12.60	27.60	54.79	0.3110
MAD160C-0100	1 000	6 000	225	490.0	23.56	52.90	112.30	0.3110
MAD160C-0150	1 500	8 000	215	496.0	33.80	75.30	152.56	0.3110
MAD160C-0200	2 000	8 000	210	494.2	44.00	93.90	182.40	0.3110
MAD180C-0050	500	3 000	325	715.5	17.00	38.20	76.57	0.4580
MAD180C-0100	1 000	6 000	300	726.4	31.40	69.00	147.55	0.4580
MAD180C-0150	1 500	6 000	270	681.0	42.40	88.60	182.12	0.4580
MAD180C-0200	2 000	6 000	250	594.4	52.40	104.60	221.71	0.4580
MAD180D-0050	500	3 000	390	857.8	20.40	39.70	78.42	0.5940
MAD180D-0100	1 000	6 000	370	901.5	38.70	82.40	188.01	0.5940
MAD180D-0150	1 500	6 000	340	794.0	53.40	107.40	220.80	0.5940
MAD180D-0200	2 000	6 000	300	768.2	62.80	117.40	269.69	0.5940
MAD225C-0050	500	3 000	660	1 450.0	34.56	72.00	151.92	1.6500
MAD225C-0100	1 000	3 750	640	1 450.0	67.02	121.03	265.86	1.6500
MAD225C-0150	1 500	3 750	593	1 450.0	93.10	174.00	376.30	1.6500

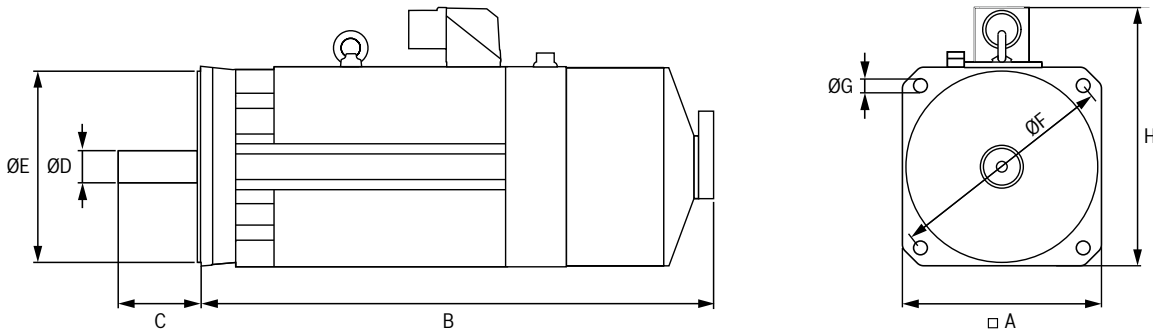
Dimensions

Type	A ¹⁾	B	C	ØD	ØE	ØF	ØG	H ²⁾	Mass
	Flange	Frame length	Shaft length	Shaft	Centering collar	Hole circle	Mounting hole	Height	Without brake
	mm	mm	mm	mm	mm	mm	mm	mm	kg
MAD160B-0050	317	748	110	55	300	350	18	395	201
MAD160B-0100	317	748	110	55	300	350	18	395	201
MAD160B-0150	317	748	110	55	300	350	18	395	201
MAD160B-0200	317	748	110	55	300	350	18	395	201
MAD160C-0050	317	838	110	55	300	350	18	395	238
MAD160C-0100	317	838	110	55	300	350	18	395	238
MAD160C-0150	317	838	110	55	300	350	18	395	238
MAD160C-0200	317	838	110	55	300	350	18	395	238
MAD180C-0050	325	979	140	60	300	350	18	467	334
MAD180C-0100	325	979	140	60	300	350	18	467	334
MAD180C-0150	325	979	140	60	300	350	18	467	334
MAD180C-0200	325	979	140	60	300	350	18	467	334
MAD180D-0050	325	1 089	140	60	300	350	18	467	403
MAD180D-0100	325	1 089	140	60	300	350	18	467	403
MAD180D-0150	325	1 089	140	60	300	350	18	467	403
MAD180D-0200	325	1 089	140	60	300	350	18	467	403
MAD225C-0050	442	1 280	140	75	350	400	18	580	610
MAD225C-0100	442	1 280	140	75	350	400	18	580	610
MAD225C-0150	442	1 280	140	75	350	400	18	580	610

¹⁾ Enclosure dimension > flange dimension A

²⁾ Motor height H for versions with plug, values for power connection with terminal box may vary and are as follows:

MAD100 = 295 mm; MAD130 = 370 mm; MAD160 = 422 mm

Asynchronous servo motor

MAF



The MAF series liquid-cooled motors are ideal for applications where high torques are required in a confined space. At the same time, the integrated cooling system ensures thermal decoupling of motor and machine and thus maximum precision during machining. The quick couplers used with integrated leak-proofing simplify your maintenance work. With options such as holding brake, various encoder systems and vibration severity levels as well as shaft designs, you can optimally adapt the MAF motors to your application scenario.

- ▶ **Rated power (P_N) up to 120 kW**
- ▶ **Maximum speed (n_{max}) up to 11 000 min⁻¹**
- ▶ **Single-turn, multi-turn and incremental encoders**
- ▶ **High degree of protection: IP65**
- ▶ **Service-friendly motor design**
- ▶ **ATEX option**

ATEX marking

MAF with
Encoder S6/M6

 II 2G Ex px d IIB T3 Gb

Type code
MAF100C-0100-FQ-S2-A H 0-05-N 1

Motor

- ▶ Frame size (e.g. "100")
- ▶ Frame length (e.g. "C")
- ▶ Winding (e.g. "0100")

Cooling connection

- FQ** = Connection thread
- FR** = Quick coupling

Encoder

- S2** = Single-turn encoder (EnDat), 2 048 signal periods
- M2** = Multi-turn encoder (EnDat), 2 048 signal periods with 4 096 revolutions absolute
- S6** = S2 encoder for ATEX
- M6** = M2 encoder for ATEX
- C0** = Incremental encoder 2 048 increments

Electrical connection

Plug

- A** = To the A side
- B** = To the B side
- L** = To the left
- R** = To the right

Terminal box, turnable

- E** = To the A side
- H** = To the B side
- G** = To the left
- D** = To the right

Vibration severity

- 1** = A
- 3** = B
- 4** = C

Bearing

- N** = Standard
- A** = A-side fixed bearing
- H** = High-speed
- V** = Heavy duty

Design

- 05** = Flange mounting
- 35** = Flange or foot mounting

Holding brake

- 0** = Without holding brake
- 1** = With releasing holding brake
- 3** = With releasing holding brake, heavy duty
- 5** = With clamping holding brake

Shaft design

- Smooth shaft
- H** = Without shaft seal ring
- G** = With shaft seal ring (IP65)
- F** = With labyrinth seal ring

Keyway

- Q** = Without shaft seal ring
- P** = With shaft seal ring (IP65)
- R** = With labyrinth seal ring

Available options and technical specifications: see project planning instructions: www.boschrexroth.com/cat-maf

MAF

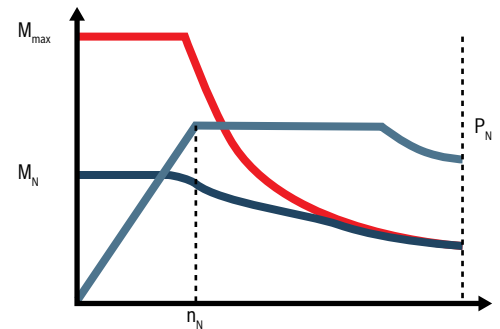

■ For more information, please visit: www.boschrexroth.com/cat-maf

Technical specifications									
Type	Rated speed	Maximum speed	Rated torque	Maximum torque	Rated power	Rated current	Maximum current	Moment of inertia	
	n_N	n_{max}	M_N	M_{max}	P_N	I_N	I_{max}	Without brake	
	min^{-1}	min^{-1}	Nm	Nm	kW	A	A	$J_{R, w/o br.}$ kg·m ²	
MAF100B-0050	500	3 000	50	109.7	2.60	8.50	20.29	0.0190	
MAF100B-0100	1 000	6 000	46	110.0	4.82	15.20	33.30	0.0190	
MAF100B-0150	1 500	9 000	42	101.4	6.60	18.10	46.17	0.0190	
MAF100B-0200	2 000	11 000	38	92.4	8.00	23.90	51.69	0.0190	
MAF100B-0250	2 500	11 000	33	83.6	8.64	26.00	50.67	0.0190	
MAF100C-0050	500	3 000	70	153.7	3.90	12.10	25.60	0.0284	
MAF100C-0100	1 000	6 000	68	154.0	7.50	19.00	41.37	0.0284	
MAF100C-0150	1 500	9 000	66	149.5	10.40	27.90	60.39	0.0284	
MAF100C-0200	2 000	11 000	64	145.2	13.40	36.70	77.50	0.0284	
MAF100C-0250	2 500	11 000	62	138.1	16.23	40.20	85.84	0.0284	
MAF100D-0050	500	3 000	88	193.3	4.60	14.50	29.20	0.0320	
MAF100D-0100	1 000	6 000	84	190.0	8.80	27.10	58.03	0.0320	
MAF100D-0150	1 500	9 000	79	185.3	12.40	32.70	68.73	0.0320	
MAF100D-0200	2 000	11 000	80	182.3	16.76	43.10	91.33	0.0320	
MAF100D-0250	2 500	11 000	75	177.5	19.63	42.82	100.42	0.0320	
MAF130B-0050	500	3 000	116	254.7	6.10	14.70	30.48	0.0790	
MAF130B-0100	1 000	6 000	112	254.7	11.70	28.40	60.95	0.0790	
MAF130B-0150	1 500	9 000	115	264.0	18.10	43.70	94.68	0.0790	
MAF130B-0200	2 000	10 000	100	220.0	20.90	52.70	108.94	0.0790	
MAF130B-0250	2 500	10 000	90	210.0	23.56	58.80	126.61	0.0790	
MAF130C-0050	500	3 000	155	340.0	8.10	21.00	42.64	0.1010	
MAF130C-0100	1 000	6 000	150	330.0	15.70	38.00	71.80	0.1010	
MAF130C-0150	1 500	9 000	145	329.8	22.80	53.20	111.02	0.1010	
MAF130C-0200	2 000	10 000	135	314.7	28.30	69.80	142.91	0.1010	
MAF130C-0250	2 500	10 000	125	298.4	32.72	75.50	150.76	0.1010	
MAF130D-0050	500	3 000	230	506.3	12.00	32.30	64.35	0.1510	
MAF130D-0100	1 000	6 000	220	500.0	23.04	50.71	103.47	0.1510	
MAF130D-0150	1 500	9 000	200	484.4	31.40	72.60	155.42	0.1510	
MAF130D-0200	2 000	10 000	200	461.4	41.90	93.90	190.86	0.1510	
MAF130D-0250	2 500	10 000	190	450.0	49.74	113.00	263.52	0.1510	

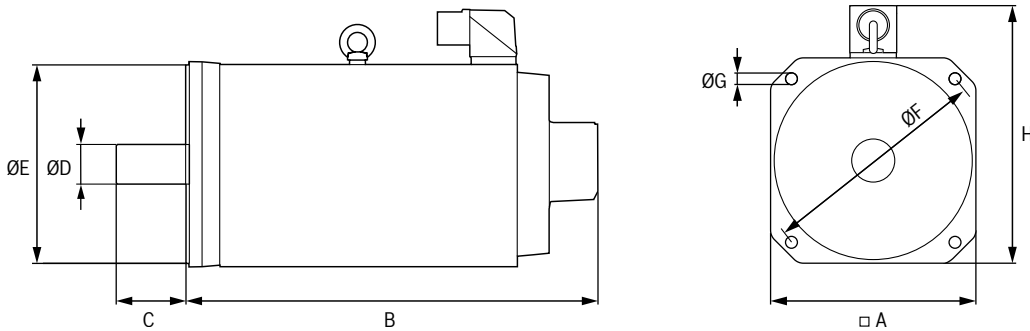

Dimensions

Type	A	B	C	ØD	ØE	ØF	ØG	H ¹⁾	Mass
	Flange	Frame length	Shaft length	Shaft	Centering collar	Hole circle	Mounting hole	Height	Without brake
	mm	mm	mm	mm	mm	mm	mm	mm	kg
MAF100B-0050	192	382	60	38	130	215	14	260	38
MAF100B-0100	192	382	60	38	130	215	14	260	38
MAF100B-0150	192	382	60	38	130	215	14	260	38
MAF100B-0200	192	382	60	38	130	215	14	260	38
MAF100B-0250	192	382	60	38	130	215	14	260	38
MAF100C-0050	192	457	60	38	130	215	14	260	52
MAF100C-0100	192	457	60	38	130	215	14	260	52
MAF100C-0150	192	457	60	38	130	215	14	260	52
MAF100C-0200	192	457	60	38	130	215	14	260	52
MAF100C-0250	192	457	60	38	130	215	14	260	52
MAF100D-0050	192	532	60	38	130	215	14	260	64
MAF100D-0100	192	532	60	38	130	215	14	260	64
MAF100D-0150	192	532	60	38	130	215	14	260	64
MAF100D-0200	192	532	60	38	130	215	14	260	64
MAF100D-0250	192	532	60	38	130	215	14	260	64
MAF130B-0050	262	413	110	42	250	300	18	340	82
MAF130B-0100	262	413	110	42	250	300	18	340	82
MAF130B-0150	262	413	110	42	250	300	18	340	82
MAF130B-0200	262	413	110	42	250	300	18	340	82
MAF130B-0250	262	413	110	42	250	300	18	340	82
MAF130C-0050	262	483	110	42	250	300	18	340	106
MAF130C-0100	262	483	110	42	250	300	18	340	106
MAF130C-0150	262	483	110	42	250	300	18	340	106
MAF130C-0200	262	483	110	42	250	300	18	340	106
MAF130C-0250	262	483	110	42	250	300	18	340	106
MAF130D-0050	262	613	110	42	250	300	18	340	147
MAF130D-0100	262	613	110	42	250	300	18	340	147
MAF130D-0150	262	613	110	42	250	300	18	340	147
MAF130D-0200	262	613	110	42	250	300	18	340	147
MAF130D-0250	262	613	110	42	250	300	18	340	147

¹⁾ Motor height H for versions with plug, values for power connection with terminal box may vary and are as follows:

MAF100 = 291 mm; MAF130 = 370 mm; MAF160 = 422 mm.

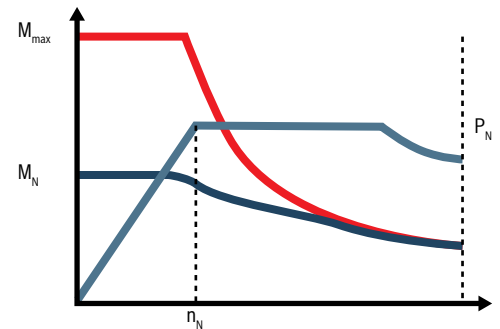
MAF



■ For more information, please visit: www.boschrexroth.com/cat-maf

Technical specifications									
Type	Rated speed	Maximum speed	Rated torque	Maximum torque	Rated power	Rated current	Maximum current	Moment of inertia	
	n_N	n_{max}	M_N	M_{max}	P_N	I_N	I_{max}	Without brake	
	min^{-1}	min^{-1}	Nm	Nm	kW	A	A	$J_{R, w/o br.}$ kg·m ²	
MAF160B-0050	500	3 000	270	594.5	14.10	34.25	65.40	0.2300	
MAF160B-0100	1 000	6 000	260	592.7	27.20	73.70	149.00	0.2300	
MAF160B-0150	1 500	8 000	250	570.8	39.30	89.50	179.70	0.2300	
MAF160B-0200	2 000	8 000	240	550.1	50.30	108.50	232.70	0.2300	
MAF160C-0050	500	3 000	340	747.8	17.80	47.40	98.00	0.2600	
MAF160C-0100	1 000	6 000	325	746.4	34.00	91.20	196.00	0.2600	
MAF160C-0150	1 500	8 000	300	681.4	47.10	109.50	212.17	0.2600	
MAF160C-0200	2 000	8 000	285	677.4	59.70	123.66	290.70	0.2600	
MAF180C-0050	500	3 000	435	986.2	22.80	50.00	104.70	0.4900	
MAF180C-0100	1 000	6 000	400	957.0	41.90	93.50	191.38	0.4900	
MAF180C-0150	1 500	6 000	365	858.1	57.33	128.80	280.86	0.4900	
MAF180C-0200	2 000	6 000	318	739.2	66.60	154.00	318.90	0.4900	
MAF180D-0050	500	3 000	500	1 100.2	26.20	60.40	117.34	0.6100	
MAF180D-0100	1 000	6 000	500	1 100.2	52.36	106.50	208.20	0.6100	
MAF180D-0150	1 500	6 000	435	1 013.0	68.33	146.10	296.24	0.6100	
MAF180D-0200	2 000	6 000	400	1 008.0	83.80	168.50	377.10	0.6100	
MAF225C-0050	500	3 000	860	1 750.0	45.03	98.00	207.57	1.6500	
MAF225C-0100	1 000	3 750	820	1 750.0	85.90	165.00	355.00	1.6500	
MAF225C-0150	1 500	3 750	764	1 814.0	120.01	211.20	489.20	1.6500	

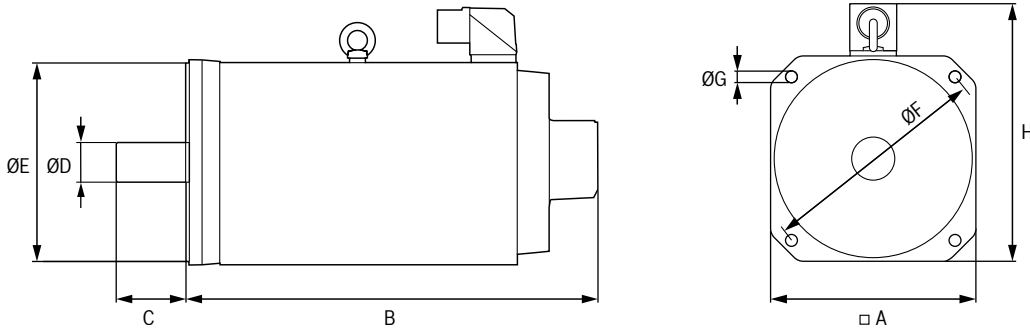
Dimensions

Type	A	B	C	ØD	ØE	ØF	ØG	H ¹⁾	Mass
	Flange	Frame length	Shaft length	Shaft	Centering collar	Hole circle	Mounting hole	Height	Without brake
	mm	mm	mm	mm	mm	mm	mm	mm	kg
MAF160B-0050	317	618	110	60	300	350	18	395	197
MAF160B-0100	317	618	110	60	300	350	18	395	197
MAF160B-0150	317	618	110	60	300	350	18	395	197
MAF160B-0200	317	618	110	60	300	350	18	395	197
MAF160C-0050	317	708	110	60	300	350	18	395	227
MAF160C-0100	317	708	110	60	300	350	18	395	227
MAF160C-0150	317	708	110	60	300	350	18	395	227
MAF160C-0200	317	708	110	60	300	350	18	395	227
MAF180C-0050	325	792	140	60	300	350	18	467	322
MAF180C-0100	325	792	140	60	300	350	18	467	322
MAF180C-0150	325	792	140	60	300	350	18	467	322
MAF180C-0200	325	792	140	60	300	350	18	467	322
MAF180D-0050	325	902	140	60	300	350	18	467	382
MAF180D-0100	325	902	140	60	300	350	18	467	382
MAF180D-0150	325	902	140	60	300	350	18	467	382
MAF180D-0200	325	902	140	60	300	350	18	467	382
MAF225C-0050	441	932	140	75	350	400	18	572	587
MAF225C-0100	441	932	140	75	350	400	18	572	587
MAF225C-0150	441	932	140	75	350	400	18	572	587

¹⁾ Motor height H for versions with plug, values for power connection with terminal box may vary and are as follows:

MAF100 = 291 mm; MAF130 = 370 mm; MAF160 = 422 mm.

Servo planetary gearbox

GTE



The compact planetary gearboxes of the GTE series, together with our dynamic servo motors, ensure high torques in all standard applications. Typical areas of application are simple handling or automation systems with pinion, rack and pinion or tooth belt drives. With the finely graduated sizes and the high power density of the GTE gearboxes, they cover almost all power requirements in these applications. The single-stage or two-stage gearboxes are optionally available with smooth shaft or keyway.

- ▶ **Low torsional backlash**
- ▶ **Any installation position**
- ▶ **Quiet operation**
- ▶ **Life long lubrication**

Type code
GTE060-NN1-003 A-NN03

Size
 ▶ Frame size (e.g. "060")

Stages
1 = Single-stage
2 = Two-stage

Transmission ratio
003 = Single-stage 3:1
004 = Single-stage 4:1
005 = Single-stage 5:1
008 = Single-stage 8:1
010 = Single-stage 10:1
012 = Two-stage 12:1
020 = Two-stage 20:1
040 = Two-stage 40:1

Output shaft and backlash
A = With keyway
B = Smooth shaft

Motor-gearbox combination

Gearboxes		GTE040	GTE060	GTE080	GTE120	GTE160
Motors						
MSM	019A	NN45				
	019B	NN45				
	031B		NN42			
	031C			NN43		
	041B			NN44	NN44	
MS2N	03-B		NN02	NN02		
	03-D		NN50	NN50		
	04-x			NN03	NN03	
	05-x				NN20	NN20
	06-x				NN21 ¹⁾	NN21
	07-x					NN16
KSM	041			NN03	NN03	
	061				NN05 ¹⁾	NN05
	071					NN16
	076					NN06

¹⁾ Preassembled in the factory, only available with single-stage transmission.
 Available options and technical specifications: see project planning instructions: www.boschrexroth.com/cat-gte

GTE

■ For more information, please visit: www.boschrexroth.com/cat-gte

Technical specifications								
Type	Transmission ratio		Rated input speed		Max. input speed	Max. output speed	Rated input torque	Rated output torque
			at 50 % $M_{OUT\ N}$	at 100 % $M_{OUT\ N}$				
	Stages	i	$n_{IN\ N}$ min ⁻¹	$n_{IN\ N}$ min ⁻¹	$n_{IN\ max}$ min ⁻¹	$n_{OUT\ max}$ min ⁻¹	$M_{IN\ N}$ Nm	$M_{OUT\ N}$ Nm
GTE040-NN1-003	Single-stage	3	5 000	5 000	18 000	6 000	3.70	11
GTE040-NN1-004		4	5 000	5 000	18 000	4 500	3.80	15
GTE040-NN1-005		5	5 000	5 000	18 000	3 600	2.80	14
GTE040-NN1-008		8	5 000	5 000	18 000	2 250	0.80	6
GTE040-NN1-010		10	5 000	5 000	18 000	1 800	0.50	5
GTE040-NN2-012	Two-stage	12	5 000	5 000	18 000	1 500	1.70	20
GTE040-NN2-020		20	5 000	5 000	18 000	900	1.00	20
GTE040-NN2-040		40	5 000	5 000	18 000	450	0.50	18
GTE060-NN1-003	Single-stage	3	4 500	4 500	13 000	4 333	9.30	28
GTE060-NN1-004		4	4 500	4 500	13 000	3 250	9.50	38
GTE060-NN1-005		5	4 500	4 500	13 000	2 600	8.00	40
GTE060-NN1-008		8	4 500	4 500	13 000	1 625	2.30	18
GTE060-NN1-010		10	4 500	4 500	13 000	1 300	1.50	15
GTE060-NN2-012	Two-stage	12	4 500	4 500	13 000	1 083	3.70	44
GTE060-NN2-020		20	4 500	4 500	13 000	650	2.20	44
GTE060-NN2-040		40	4 500	4 500	13 000	325	1.00	40
GTE080-NN1-003	Single-stage	3	4 000	2 700	7 000	2 333	28.30	85
GTE080-NN1-004		4	3 850	2 500	7 000	1 750	28.80	115
GTE080-NN1-005		5	4 000	3 000	7 000	1 400	22.00	110
GTE080-NN1-008		8	4 000	4 000	7 000	875	6.30	50
GTE080-NN1-010		10	4 000	4 000	7 000	700	3.80	38
GTE080-NN2-012	Two-stage	12	4 000	3 750	7 000	583	10.00	120
GTE080-NN2-020		20	4 000	4 000	7 000	350	6.00	120
GTE080-NN2-040		40	4 000	4 000	7 000	175	2.80	110
GTE120-NN1-003	Single-stage	3	3 350	2 550	6 500	2 167	38.30	115
GTE120-NN1-004		4	3 400	2 500	6 500	1 625	38.38	155
GTE120-NN1-005		5	3 500	2 500	6 500	1 300	39.00	195
GTE120-NN1-008		8	3 500	3 500	6 500	813	15.00	120
GTE120-NN1-010		10	3 500	3 500	6 500	650	9.50	95
GTE120-NN2-012	Two-stage	12	3 500	2 650	6 500	542	21.70	260
GTE120-NN2-020		20	3 500	3 500	6 500	325	13.00	260
GTE120-NN2-040		40	3 500	3 500	6 500	163	5.80	230

When designing the products, the specified dependencies in the project planning instructions must be observed!

Technical specifications							
Type	Max. input torque	Max. output torque	Torsional backlash	Torsional stiffness	Levels of efficiency	Moment of inertia	Mass
	$M_{IN\ max}$	$M_{OUT\ max}$		D	η	J	
	Nm	Nm		arcmin	Nm/arcmin	%	
GTE040-NN1-003	5.90	17.6	< 15	1.0	98	0.031	0.35
GTE040-NN1-004	6.00	24.0	< 15	1.0	98	0.022	0.35
GTE040-NN1-005	4.40	22.0	< 15	1.0	98	0.019	0.35
GTE040-NN1-008	1.25	10.0	< 15	1.0	96	0.017	0.35
GTE040-NN1-010	0.80	8.0	< 15	1.0	95	0.016	0.35
GTE040-NN2-012	2.70	32.0	< 19	1.1	96	0.029	0.45
GTE040-NN2-020	1.60	32.0	< 19	1.1	96	0.019	0.45
GTE040-NN2-040	0.73	29.0	< 19	1.1	94	0.016	0.45
GTE060-NN1-003	15.00	45.0	< 10	2.3	98	0.135	0.90
GTE060-NN1-004	15.25	61.0	< 10	2.3	98	0.093	0.90
GTE060-NN1-005	12.80	64.0	< 10	2.3	98	0.078	0.90
GTE060-NN1-008	3.63	29.0	< 10	2.3	97	0.065	0.90
GTE060-NN1-010	2.40	24.0	< 10	2.3	96	0.064	0.90
GTE060-NN2-012	5.83	70.0	< 12	2.5	96	0.127	1.10
GTE060-NN2-020	3.50	70.0	< 12	2.5	96	0.075	1.10
GTE060-NN2-040	1.60	64.0	< 12	2.5	94	0.064	1.10
GTE080-NN1-003	45.30	136.0	< 7	6.0	98	0.770	2.10
GTE080-NN1-004	46.00	184.0	< 7	6.0	98	0.520	2.10
GTE080-NN1-005	35.20	176.0	< 7	6.0	98	0.450	2.10
GTE080-NN1-008	10.00	80.0	< 7	6.0	97	0.390	2.10
GTE080-NN1-010	6.10	61.0	< 7	6.0	96	0.390	2.10
GTE080-NN2-012	16.00	192.0	< 9	6.5	97	0.720	2.60
GTE080-NN2-020	9.60	192.0	< 9	6.5	96	0.440	2.60
GTE080-NN2-040	4.40	176.0	< 9	6.5	94	0.390	2.60
GTE120-NN1-003	61.30	184.0	< 7	12.0	98	2.630	6.00
GTE120-NN1-004	62.00	248.0	< 7	12.0	98	1.790	6.00
GTE120-NN1-005	62.40	312.0	< 7	12.0	98	1.530	6.00
GTE120-NN1-008	24.00	192.0	< 7	12.0	98	1.320	6.00
GTE120-NN1-010	15.20	152.0	< 7	12.0	97	1.300	6.00
GTE120-NN2-012	34.70	416.0	< 9	13.0	96	2.560	8.00
GTE120-NN2-020	20.80	416.0	< 9	13.0	96	1.500	8.00
GTE120-NN2-040	9.20	368.0	< 9	13.0	94	1.300	8.00

GTE

■ For more information, please visit: www.boschrexroth.com/cat-gte

Technical specifications								
Type	Transmission ratio		Rated input speed		Max. input speed	Max. output speed	Rated input torque	Rated output torque
			at 50 % $M_{OUT\ N}$	at 100 % $M_{OUT\ N}$				
	Stages	i	$n_{IN\ N}$ min ⁻¹	$n_{IN\ N}$ min ⁻¹	$n_{IN\ max}$ min ⁻¹	$n_{OUT\ max}$ min ⁻¹	$M_{IN\ N}$ Nm	$M_{OUT\ N}$ Nm
GTE160-NN1-003	Single-stage	3	1 350	900	6 500	2 167	133.30	400
GTE160-NN1-004		4	1 450	1 000	6 500	1 625	112.50	450
GTE160-NN1-005		5	1 650	1 150	6 500	1 300	90.00	450
GTE160-NN1-008		8	2 150	1 550	6 500	813	56.30	450
GTE160-NN2-012	Two-stage	12	1 550	1 000	6 500	542	66.70	800
GTE160-NN2-020		20	2 050	1 400	6 500	325	40.00	800
GTE160-NN2-040		40	2 950	2 300	6 500	163	17.50	700

When designing the products, the specified dependencies in the project planning instructions must be observed!

Technical specifications							
Type	Max. input torque	Max. output torque	Torsional backlash	Torsional stiffness	Levels of efficiency	Moment of inertia	Mass
	$M_{IN\ max}$	$M_{OUT\ max}$		D	η	J	
	Nm	Nm		arcmin	Nm/arcmin	%	
GTE160-NN1-003	213.30	640.0	< 6	38.0	98	12.140	18.0
GTE160-NN1-004	180.00	720.0	< 6	38.0	98	7.780	18.0
GTE160-NN1-005	144.00	720.0	< 6	38.0	98	6.070	18.0
GTE160-NN1-008	90.00	720.0	< 6	38.0	97	4.630	18.0
GTE160-NN2-012	106.70	1 280.0	< 10	41.0	96	12.370	22.0
GTE160-NN2-020	64.00	1 280.0	< 10	41.0	96	6.650	22.0
GTE160-NN2-040	28.00	1 120.0	< 10	41.0	94	5.280	22.0

Servo planetary gearbox

GTM



The high-precision GTM planetary gearboxes were developed for direct mounting on servo motors and are characterized by a particularly high power density and minimum backlash. Due to their high levels of efficiency, these gearboxes are predestined for S1 continuous operation, for example in printing machines. In combination with the dynamic servo motors, they achieve the highest speeds, accelerations and optimum positioning accuracy. The single-stage or two-stage gearboxes are optionally available with smooth shaft or keyway and, on request, with reduced torsional backlash.

- ▶ **Maximum accuracy with high-precision tothing**
- ▶ **Continuous operation with minimum power loss**
- ▶ **Quiet running thanks to optimized gear tooth form**
- ▶ **Environmentally-resistant, hermetically-sealed enclosure**
- ▶ **High safety against overload thanks to form-fit force transmission**

Type code

GTM075-NN1-004 A-NN03

Size

► Frame size (e.g. "075")

Stages

1 = Single-stage

2 = Two-stage

Transmission ratio

004 = Single-stage 4:1

005 = Single-stage 5:1

007 = single-stage 7:1

008 = Single-stage 8:1

010 = Single-stage 10:1

012 = Two-stage 12:1

020 = Two-stage 20:1

040 = Two-stage 40:1

Output shaft and backlash

A = With keyway

B = Smooth shaft

C = With keyway, reduced torsional backlash

D = Smooth shaft, reduced torsional backlash

Motor-gearbox combination

Gearboxes		GTM060	GTM075	GTM100	GTM140	GTM180	GTM240
Motors							
MS2N	03-B	NN02					
	03-D	NN50	NN50				
	04-x		NN03	NN03			
	05-x		NN20	NN20	NN20		
	06-x		NN21	NN21	NN21		
	07-X			NN16	NN16	NN16	
	10-x				NN19	NN19 ¹⁾	
KSM	041	NN03	NN03	NN03			
	061		NN05	NN05	NN05		
	071			NN16	NN16	NN16	
	076			NN06	NN06		
MAD	100				NN09	NN09	
	130					NN11 ¹⁾	NN11 ¹⁾
	160						NN12 ¹⁾
MAF	100					NN08	
	130					NN11 ¹⁾	NN11 ¹⁾

¹⁾ Preassembled in the factory, only available with single-stage transmission.

Available options and technical specifications: see project planning instructions: www.boschrexroth.com/cat-gtm

GTM

■ For more information, please visit: www.boschrexroth.com/cat-gtm

Technical specifications							
Type	Transmission ratio		Rated input speed	Max. input speed	Max. output speed	Rated input torque	Rated output torque
			$n_{IN N}$	$n_{IN max}$	$n_{OUT max}$	$M_{IN N}$	$M_{OUT N}$
	Stage	i	min ⁻¹	min ⁻¹	min ⁻¹	Nm	Nm
GTM060-NN1-004	Single-stage	4	3 000	5 000	1 250	6.25	25
GTM060-NN1-005		5	4 000	6 300	1 260	5.00	25
GTM060-NN1-007		7	5 000	8 000	1 143	3.60	25
GTM060-NN1-010		10	6 000	10 000	1 000	2.00	20
GTM060-NN2-020	Two-stage	20	4 000	6 300	315	1.25	25
GTM060-NN2-050		50	6 000	10 000	200	0.50	25
GTM075-NN1-004	Single-stage	4	3 000	5 000	1 250	21.3	85
GTM075-NN1-005		5	4 000	6 300	1 260	20.0	100
GTM075-NN1-007		7	5 000	8 000	1 143	12.1	85
GTM075-NN1-010		10	6 000	10 000	1 000	6.0	60
GTM075-NN2-020	Two-stage	20	4 000	6 300	315	4.2	85
GTM075-NN2-050		50	6 000	10 000	200	2.0	100
GTM100-NN1-003	Single-stage	3	2 300	4 000	1 333	40.0	120
GTM100-NN1-004		4	2 500	4 000	1 000	42.5	170
GTM100-NN1-005		5	3 000	5 000	1 000	40.0	200
GTM100-NN1-007		7	4 000	6 300	900	24.3	170
GTM100-NN1-010		10	5 000	8 000	800	12.0	120
GTM100-NN2-020	Two-stage	20	3 000	5 000	250	8.5	170
GTM100-NN2-050		50	5 000	8 000	160	4.0	200
GTM140-NN1-003	Single-stage	3	1 800	3 200	1 067	93.3	280
GTM140-NN1-004		4	2 000	3 200	800	105.0	420
GTM140-NN1-005		5	2 500	4 000	800	100.0	500
GTM140-NN1-007		7	3 000	5 000	714	60.0	420
GTM140-NN1-010		10	4 000	6 300	630	28.0	280
GTM140-NN2-020	Two-stage	20	2 500	4 000	200	21.0	420
GTM140-NN2-050		50	4 000	6 300	126	10.0	500

When designing the products, the specified dependencies in the project planning instructions must be observed!

Technical specifications								
Type	Max. input torque	Max. output torque	Torsional backlash		Torsional stiffness	Levels of efficiency	Moment of inertia	Mass
	$M_{IN\ max}$	$M_{OUT\ max}$	Standard	Reduced	D	η	J	
	Nm	Nm	arcmin	arcmin	Nm/arcmin	%	kg·cm ²	
GTM060-NN1-004	12.5	50	≤ 6	≤ 3	3.5	97	0.16	1.6
GTM060-NN1-005	10.0	50	≤ 6	≤ 3	3.5	97	0.16	1.6
GTM060-NN1-007	7.1	50	≤ 6	≤ 3	3.5	97	0.15	1.6
GTM060-NN1-010	4.0	40	≤ 6	≤ 3	3.5	97	0.14	1.6
GTM060-NN2-020	2.5	50	≤ 8	≤ 6	3.5	94	0.12	2.2
GTM060-NN2-050	1.0	50	≤ 8	≤ 6	3.5	94	0.10	2.2
GTM075-NN1-004	42.5	170	≤ 6	≤ 3	8.2	97	0.55	2.9
GTM075-NN1-005	40.0	200	≤ 6	≤ 3	8.2	97	0.47	2.9
GTM075-NN1-007	24.3	170	≤ 6	≤ 3	8.2	97	0.41	2.9
GTM075-NN1-010	11.0	110	≤ 6	≤ 3	8.2	97	0.38	2.9
GTM075-NN2-020	8.5	170	≤ 8	≤ 6	8.2	94	0.47	3.8
GTM075-NN2-050	4.0	200	≤ 8	≤ 6	8.2	94	0.47	3.8
GTM100-NN1-003	73.3	220	≤ 4	≤ 2	24.0	97	2.80	5.7
GTM100-NN1-004	85.0	340	≤ 4	≤ 2	24.0	97	2.00	5.7
GTM100-NN1-005	80.0	400	≤ 4	≤ 2	24.0	97	1.64	5.7
GTM100-NN1-007	48.6	340	≤ 4	≤ 2	24.0	97	1.36	5.7
GTM100-NN1-010	22.0	220	≤ 4	≤ 2	24.0	97	1.22	5.7
GTM100-NN2-020	17.0	340	≤ 6	≤ 4	24.0	94	1.56	7.5
GTM100-NN2-050	8.0	400	≤ 6	≤ 4	24.0	94	1.44	7.5
GTM140-NN1-003	186.7	560	≤ 4	≤ 2	48.0	97	8.20	11.5
GTM140-NN1-004	210.0	840	≤ 4	≤ 2	48.0	97	6.75	11.5
GTM140-NN1-005	200.0	1 000	≤ 4	≤ 2	48.0	97	5.54	11.5
GTM140-NN1-007	120.0	840	≤ 4	≤ 2	48.0	97	4.59	11.5
GTM140-NN1-010	56.0	560	≤ 4	≤ 2	48.0	97	4.10	11.5
GTM140-NN2-020	42.0	840	≤ 6	≤ 4	48.0	94	5.29	15.0
GTM140-NN2-050	20.0	1 000	≤ 6	≤ 4	48.0	94	4.96	15.0

GTM

■ For more information, please visit: www.boschrexroth.com/cat-gtm

Technical specifications							
Type	Transmission ratio		Rated input speed	Max. input speed	Max. output speed	Rated input torque	Rated output torque
			$n_{IN\ N}$	$n_{IN\ max}$	$n_{OUT\ max}$	$M_{IN\ N}$	$M_{OUT\ N}$
	Stage	i	min ⁻¹	min ⁻¹	min ⁻¹	Nm	Nm
GTM180-NN1-003	Single-stage	3	1 300	2 500	833	240.0	720
GTM180-NN1-004		4	1 500	2 500	625	255.0	1 020
GTM180-NN1-005		5	2 000	3 200	640	240.0	1 200
GTM180-NN1-007		7	2 500	4 000	571	145.7	1 020
GTM180-NN1-010		10	3 000	5 000	500	72.0	720
GTM180-NN2-020	Two-stage	20	2 000	3 200	160	51.0	1 020
GTM180-NN2-050		50	3 000	5 000	100	24.0	1 200
GTM240-NN1-003	Single-stage	3	800	2 000	667	600.0	1 800
GTM240-NN1-004		4	1 000	2 000	500	625.0	2 500
GTM240-NN1-005		5	1 200	2 500	500	600.0	3 000
GTM240-NN1-007		7	1 500	3 000	429	357.1	2 500
GTM240-NN1-010		10	2 000	3 500	350	180.0	1 800

When designing the products, the specified dependencies in the project planning instructions must be observed!

Technical specifications								
Type	Max. input torque	Max. output torque	Torsional backlash		Torsional stiffness	Levels of efficiency	Moment of inertia	Mass
	$M_{IN\ max}$	$M_{OUT\ max}$	Standard	Reduced	D	η	J	
	Nm	Nm	arcmin	arcmin	Nm/arcmin	%	kg·cm ²	
GTM180-NN1-003	480.0	1 440	≤ 4	≤ 2	148.0	97	36.00	27.0
GTM180-NN1-004	510.0	2 040	≤ 4	≤ 2	148.0	97	24.50	27.0
GTM180-NN1-005	480.0	2 400	≤ 4	≤ 2	148.0	97	18.80	27.0
GTM180-NN1-007	291.4	2 040	≤ 4	≤ 2	148.0	97	14.50	27.0
GTM180-NN1-010	144.0	1 440	≤ 4	≤ 2	148.0	97	12.30	27.0
GTM180-NN2-020	102.0	2 040	≤ 6	≤ 4	148.0	94	6.95	35.0
GTM180-NN2-050	48.0	2 400	≤ 6	≤ 4	148.0	94	5.45	35.0
GTM240-NN1-003	1 000.0	3 000	≤ 4	≤ 2	340.0	97	128.00	62.0
GTM240-NN1-004	1 250.0	5 000	≤ 4	≤ 2	340.0	97	97.60	62.0
GTM240-NN1-005	1 200.0	6 000	≤ 4	≤ 2	340.0	97	76.40	62.0
GTM240-NN1-007	714.3	5 000	≤ 4	≤ 2	340.0	97	59.90	62.0
GTM240-NN1-010	300.0	3 000	≤ 4	≤ 2	340.0	97	51.10	62.0

Kit motors

Direct drive motors in kit design meet the highest demands in perfection. This applies to linear motors in terms of dynamism and feed force as well as to high torque and high speed motors in terms of torque and speed. Regardless of whether the motors are used in semiconductor production, in handling systems, in cutting or forming machine tools.

The powerful torque motors are ideal for machine tools, printing or plastics machines and offer extremely high torques with the lowest torque ripple. Liquid-cooled high-speed kit motors achieve maximum torques at very high speeds. Due to the large range of constant power and the short run-up times, they are particularly predestined for economical use in motor spindles.

- ▶ **Wide, finely graduated range for all force, torque and speed requirements**
- ▶ **Compact designs, different types of cooling and flexible assembly concepts**
- ▶ **Simple realization of innovative machine concepts with minimal design effort**
- ▶ **Easy integration into machines and automation systems**
- ▶ **Robust design with ultrahigh levels of reliability in daily operation**
- ▶ **Service-friendly installation and removal concepts**

▶ Synchronous linear motors MLF

Moving large masses with highest dynamism and speed – this is the strength of the MLF motors with iron core



▶ Synchronous linear motors ML3

Self-cooled linear motors with iron core of the ML3 series offer very high forces in the smallest installation space



► **High-speed synchronous motors MBS**

The areas of application of these water-cooled motors are in particular high-speed main spindles of modern CNC machines and complete machining centres.

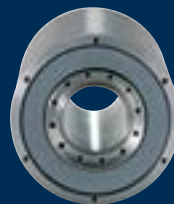

► **Synchronous linear motors MCL**

MCL ironless linear motors position small masses extremely precisely and with optimum synchronism

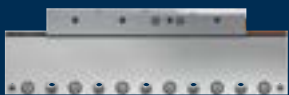

► **High-speed asynchronous motors 1MB**

Water-cooled motors 1 MB with high power density are ideal for high-dynamic main spindles of modern CNC machines including C-axis machining, thread cutting and spindle positioning



► **Synchronous torque motors MBT**

Typical applications of these water-cooled, high-torque motors are direct drives in rotary tables as well as swiveling axes in machining centers

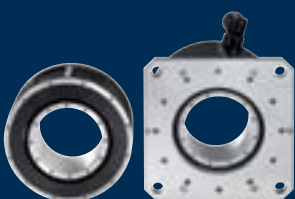

Synchronous linear motor

MCL



MCL ironless linear motors position small masses extremely precisely and with high synchronism. The difference to the iron-core variant is the ironless structure of the primary component with the completely encapsulated three-phase copper winding. The U-shaped secondary component (MCS) contains the permanent magnets and encloses the primary component (MCP). Due to this design, neither attraction forces nor detent forces occur between the primary and secondary components and the force constant is linear. These aspects, in combination with the relatively small moving mass of the primary component, allow a very high dynamism with highest precision at the same time. The compact design offers different fastening planes on the primary and secondary components and thus provides the greatest possible freedom in the design. The linear motors are optionally equipped with a Hall sensor for position detection for initial commutation.

Typical applications are applications in which small masses have to be moved very precisely at maximum possible cycle rates. These include pick-and-place machines in semiconductor technology as well as used in general automation. Due to the very high synchronous running quality of the motors, they are also predestined for use in measuring and testing machines.

- ▶ **Maximum force (F_{\max}) up to 3 320 N**
- ▶ **Max. speed at F_{\max} ($V_{F_{\max}}$) up to 820 m/min**
- ▶ **Excellent synchronization quality, no cogging forces**
- ▶ **Low dead weight, high acceleration and dynamism**
- ▶ **Easy integration due to different fastening planes**
- ▶ **Self-cooling**

Type code – primary part

MCP040 C-V070-NI-N0CN-NNNN

Frame size E.g. "040"		Hall sensor NO = Without Hall unit LO = Digital Hall unit L1 = Analog Hall unit
Frame length E.g. "C"		Winding E.g. "V070"

Type code – secondary part

MCS040-3S-0120-NNNN

Frame size E.g. "040"		Segment length C2 MCS015: 0066 = 66 mm 0099 = 99 mm MCS020-070: 0120 = 120 mm 0180 = 180 mm 0300 = 300 mm
---------------------------------	--	--

Available options and technical specifications: see project planning instructions: www.boschrexroth.com/cat-mcl

MCL

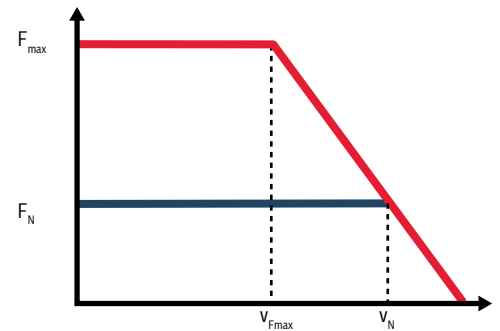

■ For more information, please visit: www.boschrexroth.com/cat-mcl

Technical specifications							
Type	Nominal force		Nominal speed		Rated current		Maximum current
	F_N	F_{max}	v_N	Maximum speed at F_{max}	I_N	I_{max}	
	N	N	m/min	m/min	A	A	
MCP015A-L040	9	36	430	90	1.5	6.0	
MCP015B-L040	18	72	480	170	3.2	12.8	
MCP020B-V180	26	104	560	200	0.8	3.2	
MCP020B-V720	26	104	1 100	690	1.4	5.6	
MCP020C-V180	39	156	550	160	1.2	4.9	
MCP020C-V720	39	156	1 095	660	2.2	8.8	
MCP020D-V180	52	208	620	220	1.7	7.0	
MCP020D-V720	52	208	1 260	820	3.2	13.0	
MCP030B-V180	48	192	510	180	1.3	5.2	
MCP030B-V390	48	192	680	400	1.6	6.4	
MCP030C-V180	74	296	460	170	1.8	7.2	
MCP030C-V390	74	296	630	370	2.4	9.6	
MCP030D-V180	105	420	440	180	2.5	10.0	
MCP030D-V390	105	420	660	380	3.5	14.0	
MCP040B-V070	73	292	290	80	1.2	4.8	
MCP040B-V300	73	292	530	290	1.9	7.6	
MCP040C-V070	108	432	290	60	1.7	6.8	
MCP040C-V300	108	432	530	310	2.9	11.6	
MCP040E-V070	183	732	280	60	2.9	11.6	
MCP040E-V300	183	732	510	260	4.7	18.8	
MCP040G-V070	258	1 032	260	50	3.9	15.6	
MCP040G-V300	258	1 032	500	290	6.6	26.4	
MCP070C-V050	215	860	180	50	2.2	8.8	
MCP070C-V300	215	860	470	340	5.1	20.4	
MCP070D-V050	286	1 144	180	50	2.8	11.2	
MCP070D-V300	286	1 144	460	280	6.4	25.6	
MCP070F-V050	428	1 712	210	70	4.6	18.4	
MCP070F-V300	428	1 712	460	290	9.0	36.0	
MCP070M-V050	830	3 320	200	60	9.0	36.0	
MCP070M-V230	830	3 320	370	230	15.7	62.8	

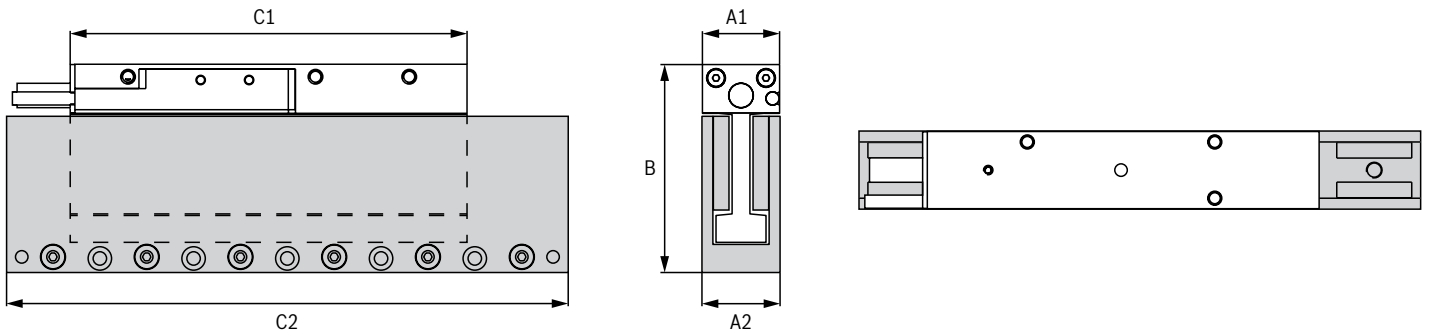
Dimensions – primary parts

Type	A1	B	C1	Mass
	mm	mm	mm	
MCP015A-L040	13.5	51.0	34	0.050
MCP015B-L040	13.5	51.0	67	0.075
MCP020B-V180	20.5	52.0	127	0.180
MCP020B-V720	20.5	52.0	127	0.180
MCP020C-V180	20.5	52.0	187	0.280
MCP020C-V720	20.5	52.0	187	0.280
MCP020D-V180	20.5	52.0	247	0.380
MCP020D-V720	20.5	52.0	247	0.380
MCP030B-V180	24.7	67.0	127	0.340
MCP030B-V390	24.7	67.0	127	0.340
MCP030C-V180	24.7	67.0	187	0.520
MCP030C-V390	24.7	67.0	187	0.520
MCP030D-V180	24.7	67.0	247	0.700
MCP030D-V390	24.7	67.0	247	0.700
MCP040B-V070	34.0	86.4	127	0.560
MCP040B-V300	34.0	86.4	127	0.560
MCP040C-V070	34.0	86.4	187	0.810
MCP040C-V300	34.0	86.4	187	0.810
MCP040E-V070	34.0	86.4	307	1.260
MCP040E-V300	34.0	86.4	307	1.260
MCP040G-V070	34.0	86.4	427	1.710
MCP040G-V300	34.0	86.4	427	1.710
MCP070C-V050	49.2	124.0	187	1.500
MCP070C-V300	49.2	124.0	187	1.500
MCP070D-V050	49.2	124.0	247	1.950
MCP070D-V300	49.2	124.0	247	1.950
MCP070F-V050	49.2	124.0	367	2.850
MCP070F-V300	49.2	124.0	367	2.850
MCP070M-V050	49.2	124.0	727	5.900
MCP070M-V230	49.2	124.0	727	5.900

Dimensions – secondary parts

Type	A2	C2	Mass
	mm	mm	
MCS015-3S-0066	14.8	66	0.2
MCS015-3S-0099	14.8	99	0.3
MCS020-3S-0120	20.8	120	0.4
MCS020-3S-0180	20.8	180	0.7
MCS020-3S-0300	20.8	300	1.1
MCS030-3S-0120	25.0	120	0.7
MCS030-3S-0180	25.0	180	1.0
MCS030-3S-0300	25.0	300	1.6
MCS040-3S-0120	34.3	120	1.3
MCS040-3S-0180	34.3	180	1.9
MCS040-3S-0300	34.3	300	3.2
MCS070-3S-0120	49.5	120	3.0
MCS070-3S-0180	49.5	180	4.5
MCS070-3S-0300	49.5	300	7.4

Synchronous linear motor

ML3



The self-cooled iron-core linear motors of the ML3 series offer high forces in the smallest installation space. Synchronous linear motors of the ML3 series are the high-output direct drive alternative to classic ball screw drives. With fewer wearing parts, higher mechanical rigidity and the highest positioning accuracy and dynamism, they contribute to a significant increase in productivity in factory automation. Thanks to the space-saving electromechanical design, these linear motors can also be installed in particularly limited installation spaces. With their high synchronous running quality, the motors achieve the highest quality in production due to their low detent forces and the resulting low force ripple. The design as a self-cooled motor series makes it possible to dispense with a coolant device on the machine and at the same time simplifies the motor installation.

An ML3 linear motor consists of one MLP3 primary component (coil) and one or more ML3S secondary components (magnetic plates). Due to the variance of the three sizes and the variable length secondary components, they cover a wide range of applications.

- ▶ **Maximum forces up to 4 500 N**
- ▶ **Max. speed at F_{\max} ($V_{F\max}$) up to 625 m/min**
- ▶ **Compact design with high force density**
- ▶ **High feed forces**
- ▶ **Low detent force and force ripple**
- ▶ **Self-cooling**

Type code – primary parts

ML3P03-ANBWN-BAFNN-NN

Frame size

E.g. "03"

Winding

E.g. "BW"

Frame length

E.g. "A"

Type code – secondary parts

ML3S03-NN-0384-NNNN

Frame size

E.g. "03"

Segment length C2

- ML3S03: 0096** = 96 mm
- 0144** = 144 mm
- 0384** = 384 mm
- ML3S06 & ML3S11: 0192** = 192 mm
- 0288** = 288 mm

Available options and technical specifications: see project planning instructions: www.boschrexroth.com/cat-ml3

ML3

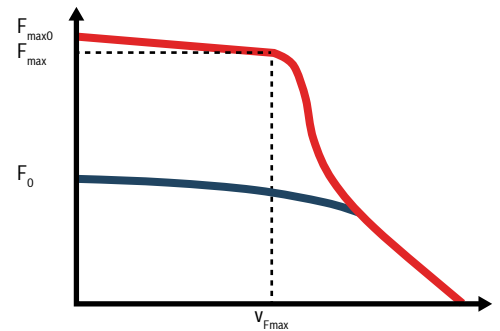

■ For more information, please visit: www.boschrexroth.com/cat-ml3

Technical specifications								
Type	Continuous standstill current	Maximum force	Maximum standstill current	Maximum speed at F_{max}	Continuous standstill current	Maximum current	Maximum standstill continuous current	
	$F_0^{1)}$	F_{max}	F_{max0}	v_{Fmax}	I_0	I_{max}	I_{max0}	
	N	N	N	m/min	A	A	A	A
ML3P03-ANBWN	60	100	120	520	1.5	2.9	4.1	
ML3P03-BNBWN	120	200	240	530	3.0	5.8	8.2	
ML3P03-DNBWN	240	400	480	525	6.0	11.6	16.4	
ML3P03-FNBNN	360	570	720	280	4.5	8.0	12.3	
ML3P03-FNBUN	360	520	720	625	9.3	14.6	25.1	
ML3P06-BNBKN	200	420	450	190	2.2	5.8	6.5	
ML3P06-BNBRN	200	390	450	415	4.3	9.7	13.1	
ML3P06-CNBCN	300	650	675	110	2.2	5.8	6.5	
ML3P06-CNBRN	300	585	675	425	6.5	14.5	19.6	
ML3P06-DNBKN	400	845	900	190	4.3	11.2	13.1	
ML3P06-DNBRN	400	780	900	420	8.6	19.4	26.2	
ML3P06-ENBKN	500	1 070	1 125	145	4.5	11.8	13.5	
ML3P06-ENBRN	500	975	1 125	425	10.8	24.1	32.7	
ML3P06-FNBKN	600	1 270	1 350	190	6.5	16.7	19.6	
ML3P06-FNBRN	600	1 170	1 350	420	13.4	30.0	41.0	
ML3P06-HNBKN	800	1 690	1 800	185	8.6	22.4	26.2	
ML3P06-HNBRN	800	1 560	1 800	420	17.2	38.5	52.0	
ML3P11-DNBFN	760	1 750	1 800	75	4.1	12.0	13.0	
ML3P11-DNBQN	760	1 680	1 800	200	8.2	22.0	26.0	
ML3P11-ENBCN	950	2 200	2 250	50	4.2	12.5	13.5	
ML3P11-ENBQN	950	2 100	2 250	200	10.2	27.2	33.0	
ML3P11-FNBFN	1 140	2 600	2 700	75	6.1	18.0	27.2	
ML3P11-HNBCN	1 520	3 500	3 600	75	6.6	19.4	20.0	
ML3P11-LNBCN	1 900	4 400	4 500	50	8.5	25.5	21.0	
ML3P11-LNBQN	1 900	4 200	4 500	200	20.5	54.5	66.0	

¹⁾ All specifications refer to an attachment surface temperature of 20 °C and a DC bus voltage of 540 V

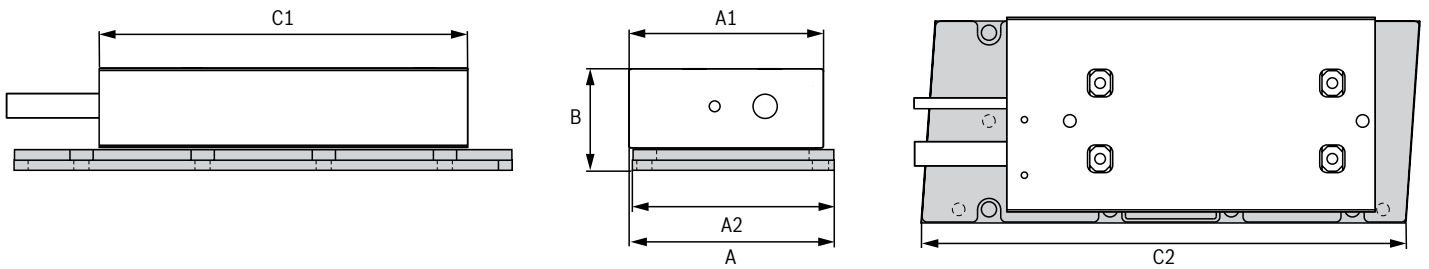
Dimensions – primary parts

Type	A1	C1	Mass
	mm	mm	kg
ML3P03-ANBWN	51.0	93	0.6
ML3P03-BNBWN	51.0	143	0.9
ML3P03-DNBWN	51.0	241	1.6
ML3P03-FNBNN	51.0	336	2.3
ML3P03-FNBUN	51.0	336	2.3
ML3P06-BNBKN	77.0	146	1.5
ML3P06-BNBRN	77.0	146	1.5
ML3P06-CNBCN	77.0	194	2.0
ML3P06-CNBRN	77.0	194	2.0
ML3P06-DNBKN	77.0	244	2.6
ML3P06-DNBRN	77.0	244	2.6
ML3P06-ENBKN	77.0	290	3.2
ML3P06-ENBRN	77.0	290	3.2
ML3P06-FNBKN	77.0	336	3.8
ML3P06-FNBRN	77.0	336	3.8
ML3P06-HNBKN	77.0	468	5.2
ML3P06-HNBRN	77.0	468	5.2
ML3P11-DNBFN	125.5	244	4.9
ML3P11-DNBQN	125.5	244	4.9
ML3P11-ENBCN	125.5	290	5.9
ML3P11-ENBQN	125.5	290	5.9
ML3P11-FNBFN	125.5	336	6.9
ML3P11-HNBCN	125.5	468	9.4
ML3P11-LNBCN	125.5	562	11.6
ML3P11-LNBQN	125.5	562	11.6

Dimensions – secondary parts

Type	A2	C2	Mass
	mm	mm	kg
ML3S03-NN-0096	50	96	0.20
ML3S03-NN-0144	50	144	0.30
ML3S03-NN-0384	50	384	0.81
ML3S06-NN-0192	80	192	0.73
ML3S06-NN-0288	80	288	1.09
ML3S11-NN-0192	130	192	2.02
ML3S11-NN-0288	130	288	3.02

Dimensions – total

	A	B
Primary component with secondary component	mm	mm
ML3P03 with ML3S03	53	40
ML3P06 with ML3S06	81	40
ML3P11 with ML3S11	130	45

Synchronous linear motor

MLF



Compact design, high degree of protection and enormous maximum forces – these are the characteristics with which MLF synchronous linear motors meet the challenges of machine tools. Together with the low force ripple, these motors are ideal for fast movement of large masses in rough environments. Due to the complete encapsulation with titanium-alloyed stainless steel sheet, the motors are suitable for use in the immediate machining area of machine tools. Practical sizes in standard encapsulations or thermal encapsulation for minimal heat input into the machine are available. The combination of several linear motors – whether in series or parallel – leads to completely new machine concepts with significantly increased machining forces.

An MLF linear motor consists of one MLP primary part (coil) and one or more MLS secondary parts (magnetic plates).

- ▶ **Maximum force (F_{\max}) up to 21 500 N**
- ▶ **Max. speed at F_{\max} ($V_{F_{\max}}$) up to 300 m/min**
- ▶ **Full stainless steel enclosure of secondary components in IP65**
- ▶ **Minimum heat dissipation in the application by water cooling**
- ▶ **Increasing the feed forces using series or parallel circuit**

Type code – primary parts

MLP140 C-0170-FS-N0CN-NNNN

Frame size

E.g. "140"

Encapsulation

S = Standard encapsulation
T = Thermal encapsulation

Frame length

E.g. "C"

Winding

E.g. "0170"

Type code – secondary parts

MLS140S-3A-0150-NNNN

Frame size

E.g. "140"

Segment length C2

0150 = 150 mm
0450 = 450 mm
0600 = 600 mm

Available options and technical specifications: see project planning instructions: www.boschrexroth.com/cat-mlf

MLF

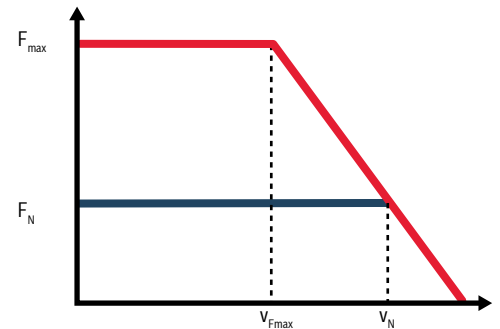

■ For more information, please visit: www.boschrexroth.com/cat-mlf

Technical specifications								
Type	Nominal force		Maximum force		Nominal speed		Maximum speed at F_{max}	
	F_N	F_{max}	v_N	v_{Fmax}	Rated current	Maximum current		
	N	N	m/min	m/min	A	A		
MLP040A-0300	250	800	500	300	3.8	18.0		
MLP040B-0150	370	1 150	300	150	3.9	18.7		
MLP040B-0250	370	1 150	400	250	5.6	28.3		
MLP040B-0300	370	1 150	500	300	6.3	36.9		
MLP070A-0150	550	2 000	200	150	4.5	29.6		
MLP070A-0220	550	2 000	360	220	6.1	40.5		
MLP070A-0300	550	2 000	450	300	8.0	42.0		
MLP070B-0100	820	2 600	200	100	4.6	23.6		
MLP070B-0120	820	2 600	220	120	5.9	42.8		
MLP070B-0150	820	2 600	260	150	7.3	56.8		
MLP070B-0250	820	2 600	400	250	10.4	57.1		
MLP070B-0300	820	2 600	450	300	11.6	67.7		
MLP070C-0030	1 200	1 900	70	30	3.7	6.5		
MLP070C-0120	1 200	3 800	180	120	9.2	56.9		
MLP070C-0150	1 200	3 800	250	150	11.0	65.9		
MLP070C-0240	1 200	3 800	350	240	15.6	107.9		
MLP070C-0300	1 200	3 800	450	300	18.4	106.7		
MLP100A-0090	1 180	3 750	150	90	5.9	34.2		
MLP100A-0120	1 180	3 750	190	120	7.4	40.5		
MLP100A-0150	1 180	3 750	220	150	10.0	50.8		
MLP100A-0190	1 180	3 750	290	190	11.9	69.2		
MLP100B-0030	1 785	3 000	70	30	5.1	9.7		
MLP100B-0120	1 785	5 600	190	120	12.2	71.2		
MLP100B-0250	1 785	5 600	350	250	24.1	142.6		
MLP100C-0090	2 310	7 150	170	90	12.1	83.6		
MLP100C-0120	2 310	7 150	190	120	15.0	84.9		
MLP100C-0190	2 310	7 150	290	190	24.2	147.1		
MLP100K-0040	1 480	4 675	135	40	6.3	33.6		
MLP140A-0030	1 680	3 000	75	30	5.0	10.5		
MLP140A-0120	1 680	5 200	190	120	12.1	70.8		
MLP140B-0035	2 415	7 650	85	35	7.7	41.3		
MLP140B-0090	2 415	7 650	160	90	14.0	79.3		
MLP140B-0120	2 415	7 650	190	120	17.8	103.8		

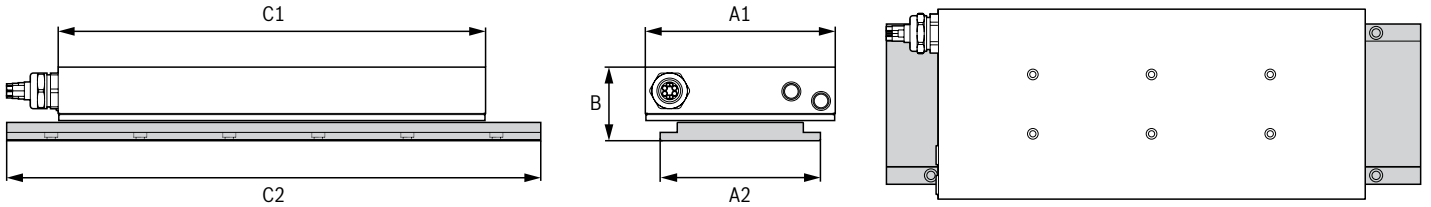

Dimensions – primary parts

Type	Standard encapsulation				Thermal encapsulation			
	A1	B	C1	Mass	A1	B	C1	Mass
	mm	mm	mm	kg	mm	mm	mm	kg
MLP040A-0300	100	61.4	210	4.7	108	73.9	235	6.1
MLP040B-0150	100	61.4	285	6.1	108	73.9	310	8.1
MLP040B-0250	100	61.4	285	6.1	108	73.9	310	8.1
MLP040B-0300	100	61.4	285	6.1	108	73.9	310	8.1
MLP070A-0150	130	61.4	285	8.4	138	73.9	310	10.9
MLP070A-0220	130	61.4	285	8.4	138	73.9	310	10.9
MLP070A-0300	130	61.4	285	8.4	138	73.9	310	10.9
MLP070B-0100	130	61.4	360	10.4	138	73.9	385	13.4
MLP070B-0120	130	61.4	360	10.4	138	73.9	385	13.4
MLP070B-0150	130	61.4	360	10.4	138	73.9	385	13.4
MLP070B-0250	130	61.4	360	10.4	138	73.9	385	13.4
MLP070B-0300	130	61.4	360	10.4	138	73.9	385	13.4
MLP070C-0030	130	61.4	510	14.3	138	73.9	535	18.4
MLP070C-0120	130	61.4	510	14.3	138	73.9	535	18.4
MLP070C-0150	130	61.4	510	14.3	138	73.9	535	18.4
MLP070C-0240	130	61.4	510	14.3	138	73.9	535	18.4
MLP070C-0300	130	61.4	510	14.3	138	73.9	535	18.4
MLP100A-0090	160	61.4	360	13.5	168	73.9	385	17.0
MLP100A-0120	160	61.4	360	13.5	168	73.9	385	17.0
MLP100A-0150	160	61.4	360	13.5	168	73.9	385	17.0
MLP100A-0190	160	61.4	360	13.5	168	73.9	385	17.0
MLP100B-0030	160	61.4	510	18.7	168	73.9	535	23.3
MLP100B-0120	160	61.4	510	18.7	168	73.9	535	23.3
MLP100B-0250	160	61.4	510	18.7	168	73.9	535	23.3
MLP100C-0090	160	61.4	660	24.0	168	73.9	685	29.7
MLP100C-0120	160	61.4	660	24.0	168	73.9	685	29.7
MLP100C-0190	160	61.4	660	24.0	168	73.9	685	29.7
MLP100K-0040	160	61.4	435	17.1	168	73.9	535	21.4
MLP140A-0030	200	61.4	360	17.0	208	73.9	385	21.2
MLP140A-0120	200	61.4	360	17.0	208	73.9	385	21.2
MLP140B-0035	200	61.4	510	24.5	208	73.9	535	30.1
MLP140B-0090	200	61.4	510	24.5	208	73.9	535	30.1
MLP140B-0120	200	61.4	510	24.5	208	73.9	535	30.1

MLF

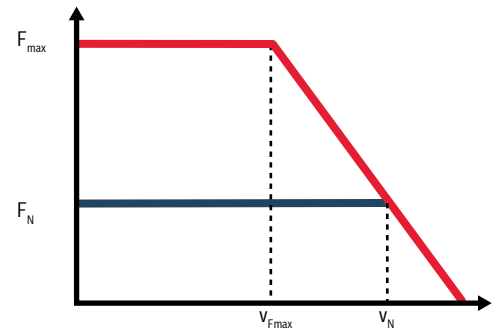

■ For more information, please visit: www.boschrexroth.com/cat-mlf

Technical specifications

Type	Nominal force		Maximum force		Nominal speed		Maximum speed at F_{max}		Rated current		Maximum current	
	F_N		F_{max}		v_N		v_{Fmax}		I_N		I_{max}	
	N		N		m/min		m/min		A		A	
MLP140C-0050	3 150		10 000		110		50		14.6		78.6	
MLP140C-0120	3 150		10 000		190		120		20.7		122.9	
MLP140C-0170	3 150		10 000		250		170		28.5		137.8	
MLP140C-0350	3 150		10 000		400		350		47.1		231.1	
MLP200A-0090	2 415		7 450		170		90		12.9		69.6	
MLP200A-0120	2 415		7 450		190		120		14.8		81.3	
MLP200B-0040	3 465		10 900		100		40		13.8		74.2	
MLP200B-0120	3 465		10 900		190		120		21.8		128.6	
MLP200C-0090	4 460		14 250		170		90		22.9		117.9	
MLP200C-0120	4 460		14 250		190		120		28.4		146.2	
MLP200C-0170	4 460		14 250		220		140		35.6		162.6	
MLP200D-0035	5 560		16 500		105		35		20.2		90.0	
MLP200D-0060	5 560		17 750		140		60		25.2		126.2	
MLP200D-0100	5 560		17 750		180		100		44.8		204.4	
MLP200D-0120	5 560		17 750		190		120		47.5		201.5	
MLP300A-0090	3 350		11 000		160		90		17.2		99.3	
MLP300A-0120	3 350		11 000		190		120		21.6		129.9	
MLP300B-0070	5 150		16 300		140		70		28.4		141.9	
MLP300B-0120	5 150		16 300		190		120		38.2		223.5	
MLP300C-0060	6 720		21 500		110		60		29.6		143.1	
MLP300C-0090	6 720		21 500		150		90		35.8		205.0	
MLP300C-0120	6 720		21 500		180		120		45.2		300.0	

Dimensions – secondary parts

Type	A2		C2		Mass	
	mm		mm		kg	
MLS040S-3A-0150	75		150		0.8	
MLS040S-3A-0450	75		450		2.4	
MLS040S-3A-0600	75		600		3.2	
MLS070S-3A-0150	105		150		1.4	
MLS070S-3A-0450	105		450		4.2	
MLS070S-3A-0600	105		600		5.6	

Dimensions – secondary parts

Type	A2		C2		Mass	
	mm		mm		kg	
MLS100S-3A-0150	135		150		2.0	
MLS100S-3A-0450	135		450		6.0	
MLS100S-3A-0600	135		600		8.0	
MLS140S-3A-0150	175		150		2.8	
MLS140S-3A-0450	175		450		8.5	
MLS140S-3A-0600	175		600		11.3	

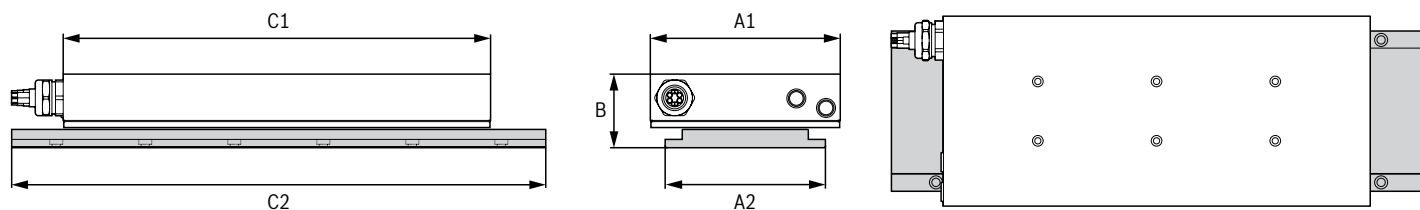
Dimensions – primary parts

Type	Standard encapsulation				Thermal encapsulation			
	A1	B	C1	Mass	A1	B	C1	Mass
	mm	mm	mm	kg	mm	mm	mm	kg
MLP140C-0050	200	61.4	660	32.0	208	73.9	685	38.9
MLP140C-0120	200	61.4	660	32.0	208	73.9	685	38.9
MLP140C-0170	200	61.4	660	32.0	208	73.9	685	38.9
MLP140C-0350	200	61.4	660	32.0	208	73.9	685	38.9
MLP200A-0090	260	61.4	360	23.0	268	73.9	385	28.3
MLP200A-0120	260	61.4	360	23.0	268	73.9	385	28.3
MLP200B-0040	260	61.4	510	33.0	268	73.9	535	40.0
MLP200B-0120	260	61.4	510	33.0	268	73.9	535	40.0
MLP200C-0090	260	61.4	660	42.0	268	73.9	685	50.7
MLP200C-0120	260	61.4	660	42.0	268	73.9	685	50.7
MLP200C-0170	260	61.4	660	42.0	268	73.9	685	50.7
MLP200D-0035	260	61.4	810	51.0	268	73.9	835	61.3
MLP200D-0060	260	61.4	810	51.0	268	73.9	835	61.3
MLP200D-0100	260	61.4	810	51.0	268	73.9	835	61.3
MLP200D-0120	260	61.4	810	51.0	268	73.9	835	61.3
MLP300A-0090	-	-	-	-	368	87.0	385	40.8
MLP300A-0120	-	-	-	-	368	87.0	385	40.8
MLP300B-0070	-	-	-	-	368	87.0	535	58.3
MLP300B-0120	-	-	-	-	368	87.0	535	58.3
MLP300C-0060	-	-	-	-	368	87.0	685	74.9
MLP300C-0090	-	-	-	-	368	87.0	685	74.9
MLP300C-0120	-	-	-	-	368	87.0	685	74.9

Dimensions – secondary parts

Type	A2	C2	Mass
	mm	mm	kg
MLS200S-3A-0150	235	150	4.0
MLS200S-3A-0450	235	450	12.1
MLS200S-3A-0600	235	600	16.1

Dimensions – secondary parts

Type	A2	C2	Mass
	mm	mm	kg
MLS300S-3A-0150	345	150	10.5
MLS300S-3A-0450	345	450	31.5
MLS300S-3A-0600	345	600	42.0

Synchronous torque motor

MBT



Torque motors are water-cooled kit motors optimized for high torques. They consist of a stator (MST) with three-phase winding and a rotor (MRT) with permanent magnets.

Typical areas of application for these motors are direct drives, e.g. in rotary tables, swivel axes of machining centers or printing units. But they also open up new solutions for innovative mechanical engineering in robots, plastics processing machines, wood working machines, lathes and special machines.

The “cooling jacket” option for the MST stators includes a cooling jacket with closed cooling circuit, mounting flange and electrical connection via terminal box or plug.

The rear side of the cooling jacket is open, the rotor is connected to the machine-side shaft and mounting. This offers users the optimum mix of standard solution and high design freedom when integrating direct-drive technology, as well as clear cost advantages due to reduced design effort and a service-friendly assembly concept.

- ▶ **Maximum torque (M_{\max}) to 13 800 Nm**
- ▶ **Maximum speed (n_{\max}) up to 4 000 min⁻¹**
- ▶ **Full torque already at standstill**
- ▶ **Extremely high overload capacity**
- ▶ **Water cooling with thermal encapsulation**

Type code – stator

MST530 B-0010-F T-N0CN-NNNN

<p>Frame size E.g. “530”</p> <p>Frame length E.g. “B”</p> <p>Winding E.g. “0010”</p>	<p>Electrical connection</p> <p>CN = Axial cable on stator side with larger outer diameter SN = Axial cable on stator side with smaller outer diameter RN = Radial cable on stator side with larger outer diameter KR = Terminal box with cable outlet right PU = Connector, turnable</p> <p>Design/encapsulation</p> <p>T = Open aluminum cooling jacket H = Integrated aluminum cooling jacket (incl. enclosure and flange) S = Self-cooling</p> <p>Type of cooling</p> <p>F = Water cooling N = Self-cooling</p>
---	---

Type code – rotor

MRT530 B-3N-0410-NNNN

<p>Frame size E.g. “530”</p> <p>Frame length E.g. “B”</p>	<p>Inner rotor diameter E.g. 0410 410 mm</p>
---	--

Available options and technical specifications: see project planning instructions: www.boschrexroth.com/cat-mbt

MBT

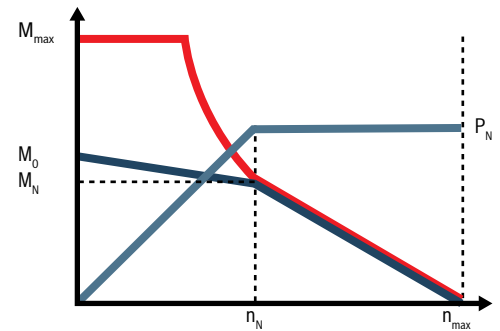

■ For more information, please visit: www.boschrexroth.com/cat-mbt

Technical specifications

Type	Rated speed	Maximum speed	Rated torque	Maximum torque	Rated power	Rated current	Maximum current	Moment of inertia
	n_N	n_{max}	M_N	M_{max}	P_N	I_N	I_{max}	$J^{1)}$
	min^{-1}	min^{-1}	Nm	Nm	kW	A	A	$\text{kg}\cdot\text{m}^2$
MST130A-0200-F	2 000	4 000	8	15	1.7	6.4	16.0	0.0001
MST130A-0250-N	2 500	4 000	5	13	1.2	3.5	12.0	0.0001
MST130C-0050-F	500	1 500	25	50	1.3	6.1	12.5	0.0020
MST130C-0075-N	750	1 500	14	40	1.1	3.5	13.0	0.0020
MST130C-0200-F	2 000	3 850	25	40	5.2	15.2	38.0	0.0020
MST130C-0300-N	3 000	3 850	7	40	2.1	5.3	26.6	0.0020
MST130E-0020-F	200	950	42	65	0.9	7.5	12.0	0.0030
MST130E-0035-N	350	950	23	65	0.6	3.5	12.0	0.0030
MST130G-0035-N	350	950	32	80	1.2	4.9	18.0	0.0040
MST160A-0050-F	500	1 100	40	90	2.1	7.5	20.0	0.0060
MST160C-0050-F	650	1 100	80	180	5.4	14.2	40.0	0.0110
MST160E-0027-F	250	450	125	270	3.3	9.8	22.4	0.0160
MST160E-0050-F	550	900	120	270	6.9	19.5	60.0	0.0160
MST161C-0140-F	1 400	1 900	52	160	7.6	17.4	53.0	0.0080
MST161E-0050-F	675	1 050	110	260	5.5	16.7	45.8	0.0150
MST161E-0140-F	1 000	2 000	95	260	10.0	32.0	84.0	0.0150
MST201C-0010-F	120	300	105	250	1.3	5.2	12.4	0.0230
MST201C-0027-F	330	540	105	250	3.6	9.4	25.7	0.0230
MST201D-0010-F	120	255	160	384	2.0	6.9	17.9	0.0340
MST201D-0027-F	330	520	140	350	4.8	13.0	31.0	0.0340
MST210A-0027-F	400	720	50	120	1.4	7.0	25.0	0.0120
MST210C-0027-F	330	950	120	250	3.4	13.0	50.0	0.0230
MST210C-0050-F	750	1 350	120	250	6.3	25.0	100.0	0.0230
MST210D-0070-F	700	1 100	150	300	11.0	32.0	120.0	0.0270
MST210E-0027-F	330	600	240	500	6.8	24.0	90.0	0.0420
MST210U-0030-F	320	580	530	1 200	17.8	45.7	165.0	0.0920
MST251F-0040-F	400	700	546	1 250	22.2	59.0	177.0	0.0850
MST290B-0018-F	180	340	220	460	4.1	14.8	0.1	0.0800
MST290D-0002-F	25	120	350	700	0.9	6.3	0.1	0.1100
MST290D-0004-F	45	150	350	700	1.7	10.4	30.0	0.1100
MST290D-0018-F	180	400	350	700	6.6	26.0	100.0	0.1100
MST290E-0004-F	40	145	575	1 150	2.4	12.5	50.0	0.1700

¹⁾ Depending on the rotor version.

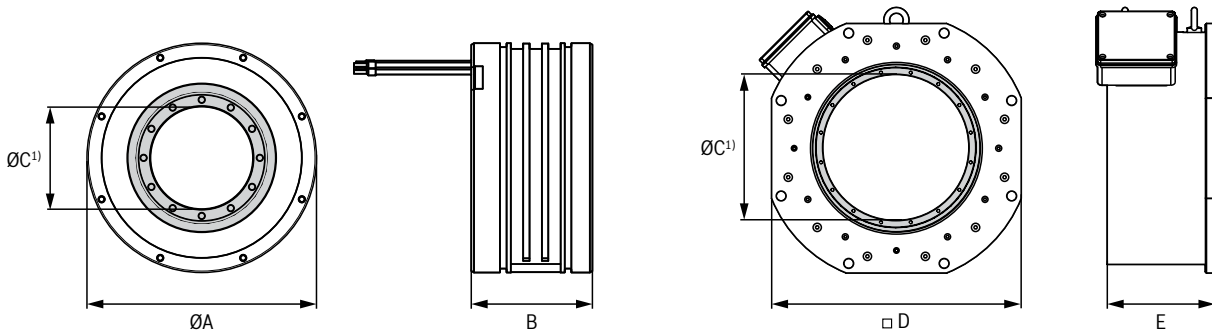
Dimensions

Type	ØA	B	ØC ¹⁾	D	E	Mass	
						Stator ²⁾	Rotor ³⁾
	mm	mm	mm	mm	mm	kg	kg
MST130A-0200-F	150	63	60	-	-	2.4	0.7
MST130A-0250-N	150	73	60	-	-	3.6	0.7
MST130C-0050-F	150	103	60	-	-	5.4	1.5
MST130C-0075-N	150	113	60	-	-	5.9	1.5
MST130C-0200-F	150	103	60	-	-	5.4	1.5
MST130C-0300-N	150	113	60	-	-	5.9	1.5
MST130E-0020-F	150	143	60	-	-	7.7	2.2
MST130E-0035-N	150	153	60	-	-	8.3	2.2
MST130G-0035-N	150	193	60	-	-	10.6	3.0
MST160A-0050-F	180	95	80	-	-	5.6	2.4
MST160C-0050-F	180	145	80	-	-	9.6	4.3
MST160E-0027-F	180	195	80	-	-	13.9	6.2
MST160E-0050-F	180	195	80	-	-	13.9	6.2
MST161C-0140-F	180	120	80	-	-	6.6	3.0
MST161E-0050-F	180	200	80	-	-	13.9	6.3
MST161E-0140-F	180	200	80	-	-	13.9	6.3
MST201C-0010-F	220	120	110	-	-	11.0	4.5
MST201C-0027-F	220	120	110	-	-	11.0	4.5
MST201D-0010-F	220	160	110	-	-	14.6	6.8
MST201D-0027-F	220	160	110	-	-	14.6	6.8
MST210A-0027-F	230	75	120	260	140	7.2	3.0
MST210C-0027-F	230	120	120	260	185	11.5	4.8
MST210C-0050-F	230	120	120	260	185	11.5	4.8
MST210D-0070-F	230	150	120	260	215	13.8	5.8
MST210E-0027-F	230	195	120	260	260	18.8	7.8
MST210U-0030-F	230	390	120	-	-	25.0	16.0
MST251F-0040-F	270	245	145	-	-	28.0	16.0
MST290B-0018-F	310	105	200	385	172	13.5	6.2
MST290D-0002-F	310	135	200	385	202	20.0	9.0
MST290D-0004-F	310	135	200	385	202	20.0	9.0
MST290D-0018-F	310	135	200	385	202	20.0	9.0
MST290E-0004-F	310	195	200	385	262	25.1	11.6

¹⁾ Depending on the rotor version.

²⁾ Stator for version with open cooling jacket.

³⁾ Rotor with largest inner rotor diameter.

MBT

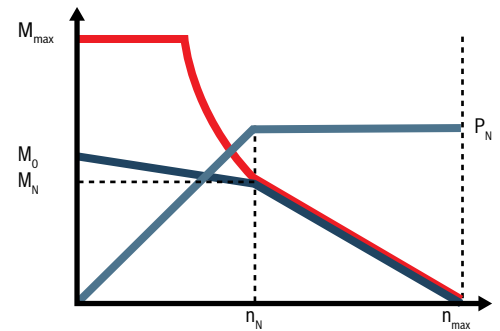

■ For more information, please visit: www.boschrexroth.com/cat-mbt

Technical specifications								
Type	Rated speed	Maximum speed	Rated torque	Maximum torque	Rated power	Rated current	Maximum current	Moment of inertia
	n_N	n_{max}	M_N	M_{max}	P_N	I_N	I_{max}	$J^{1)}$
	min^{-1}	min^{-1}	Nm	Nm	kW	A	A	$\text{kg}\cdot\text{m}^2$
MST290E-0018-F	240	415	563	1 150	10.8	34.3	125.0	0.1700
MST290F-0020-F	265	425	715	1 450	15.0	39.9	120.0	0.2000
MST290G-0020-F	263	425	810	1 600	17.0	43.7	118.0	0.2350
MST291C-0018-F	230	700	280	620	6.7	17.9	42.2	0.0780
MST291D-0010-F	100	250	440	1 000	4.6	17.6	44.0	0.1160
MST291E-0010-F	140	245	570	1 250	5.9	20.0	50.0	0.1540
MST360B-0006-F	60	200	375	800	2.4	8.8	21.5	0.1900
MST360B-0018-F	180	330	375	900	7.1	20.0	70.0	0.1900
MST360D-0009-F	90	180	525	1 150	4.9	12.0	31.0	0.2700
MST360D-0012-F	120	180	525	1 150	6.6	16.5	60.0	0.2700
MST360D-0018-F	180	300	525	1 150	9.9	28.0	100.0	0.2700
MST360E-0008-F	80	140	875	1 900	7.3	21.0	44.0	0.4400
MST360E-0018-F	180	300	875	1 900	16.5	42.0	141.0	0.4400
MST450B-0012-F	120	250	540	1 200	6.8	22.0	70.0	0.4500
MST450D-0006-F	60	140	810	1 800	5.1	18.8	50.0	0.6400
MST450D-0012-F	120	220	810	1 800	10.2	33.0	100.0	0.6400
MST450E-0006-F	80	135	1 400	3 250	8.8	32.0	88.0	1.0100
MST450E-0011-N	110	135	560	3 250	6.5	12.8	88.0	1.0100
MST450E-0012-F	135	195	1 400	3 250	17.6	46.0	125.0	1.0100
MST450E-0018-N	180	195	560	3 250	10.2	17.7	125.0	1.0100
MST530B-0010-F	100	200	800	1 800	8.4	28.6	71.0	0.9200
MST530C-0010-F	100	140	1 200	2 700	12.6	31.2	88.0	1.2500
MST530C-0010-N	100	140	580	2 700	6.1	15.0	88.0	1.2500
MST530E-0010-F	90	200	2 100	4 700	22.0	64.0	212.0	1.9200
MST530G-0006-F	60	105	4 200	9 200	26.4	73.0	240.0	3.8400
MST530G-0007-F	70	115	4 200	9 200	31.0	79.4	305.0	3.8400
MST530G-0010-F	100	160	4 200	9 200	44.0	116.8	350.0	3.8400
MST530L-0003-F	30	55	6 300	11 000	19.8	57.8	120.0	5.7600
MST530L-0006-F	60	110	6 300	13 800	39.6	120.0	279.0	5.7600
MST530L-0007-F	70	110	6 300	13 800	46.2	133.0	308.0	5.7600
MST531E-0006-F	60	95	2 150	5 000	13.5	36.5	95.0	2.3000
MST531E-0018-F	180	230	1 800	5 000	33.9	76.5	210.0	2.3000
MST531L-0009-F	90	110	5 000	12 000	47.1	98.0	240.0	5.8000

¹⁾ Depending on the rotor version.

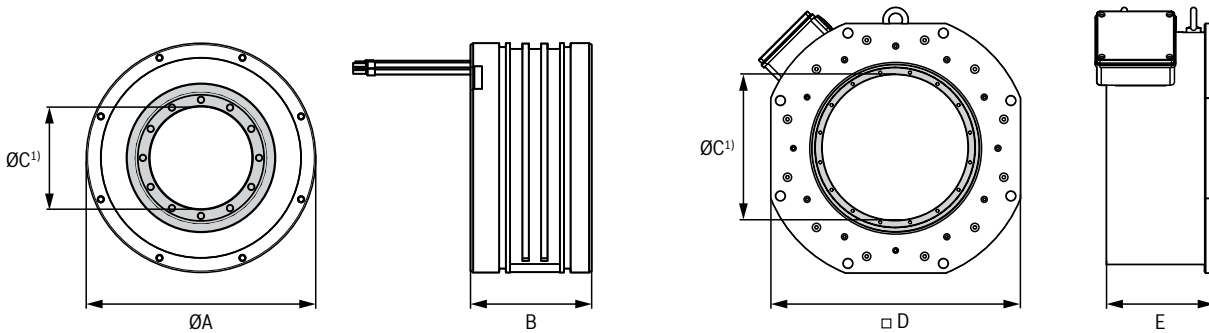
Dimensions

Type	ØA	B	ØC ¹⁾	D	E	Mass	
						Stator ²⁾	Rotor ³⁾
	mm	mm	mm	mm	mm	kg	kg
MST290E-0018-F	310	195	200	385	262	25.1	11.6
MST290F-0020-F	310	240	200	-	-	26.5	13.6
MST290G-0020-F	310	270	200	-	-	30.6	15.7
MST291C-0018-F	310	120	200	-	-	16.4	6.5
MST291D-0010-F	310	160	200	-	-	18.9	11.0
MST291E-0010-F	310	200	200	-	-	25.0	14.3
MST360B-0006-F	385	120	260	450	195	23.0	9.8
MST360B-0018-F	385	120	260	450	195	23.0	9.8
MST360D-0009-F	385	150	260	450	225	28.8	13.5
MST360D-0012-F	385	150	260	450	225	28.8	13.5
MST360D-0018-F	385	150	260	450	225	28.8	13.5
MST360E-0008-F	385	210	260	450	285	40.3	20.9
MST360E-0018-F	385	210	260	450	285	40.3	20.9
MST450B-0012-F	480	120	350	570	200	31.0	13.0
MST450D-0006-F	480	150	350	570	230	38.7	17.9
MST450D-0012-F	480	150	350	570	230	38.7	17.9
MST450E-0006-F	480	210	350	570	290	54.2	27.7
MST450E-0011-N	480	210	350	-	-	84.0	27.7
MST450E-0012-F	480	210	350	570	290	54.2	27.7
MST450E-0018-N	480	210	350	-	-	84.0	27.7
MST530B-0010-F	565	120	410	645	200	36.0	22.0
MST530C-0010-F	565	150	410	645	230	45.0	27.5
MST530C-0010-N	565	150	410	-	-	71.0	27.5
MST530E-0010-F	565	210	410	645	290	74.5	38.5
MST530G-0006-F	565	370	410	645	455	144.0	77.0
MST530G-0007-F	565	370	410	645	455	144.0	77.0
MST530G-0010-F	565	370	410	645	455	144.0	77.0
MST530L-0003-F	565	520	410	645	605	205.0	115.0
MST530L-0006-F	565	520	410	645	605	205.0	115.0
MST530L-0007-F	565	520	410	645	605	205.0	115.0
MST531E-0006-F	565	210	410	-	-	53.0	47.0
MST531E-0018-F	565	210	410	-	-	53.0	47.0
MST531L-0009-F	565	550	410	-	-	158.0	130.0

¹⁾ Depending on the rotor version.

²⁾ Stator for version with open cooling jacket.

³⁾ Rotor with largest inner rotor diameter.

Synchronous high-speed motor

MBS



The water-cooled high-speed kit motors achieve the highest torques and speeds. Due to the large range of constant power, short ramp-up time and low rotor temperature, they are predestined for motor spindles and similar areas of application. The innovative cooling system, which is already closed in the motor, simplifies integration into the machine and increases cooling efficiency. For particularly easy assembly and disassembly, the rotor can also be supplied with a step interference fit and in a hydraulically detachable version on request.

- ▶ **Maximum torque (M_{\max}) to 4 500 Nm**
- ▶ **Maximum speed (n_{\max}) up to 22 500 min⁻¹**
- ▶ **Large range of constant power**
- ▶ **Integrated water cooling**
- ▶ **Simplified integration with the machine**

Type code – stator
MSS182 A-0100-FA-NOCN-NNNN

Frame size E.g. "182"		Cooling connection A = Axial R = Radial
Frame length E.g. "A"		
Winding E.g. "0100"		

Type code – rotor
MRS182 A-1N-0085-NNNN

Frame size E.g. "182"		Inner rotor diameter E.g. 0085 = 85 mm
Frame length E.g. "A"		Design 1N = Smooth bore 2N = Step interference fit with pressure pipe connection for disassembly

Available options and technical specifications: see project planning instructions: www.boschrexroth.com/cat-mbs

MBS

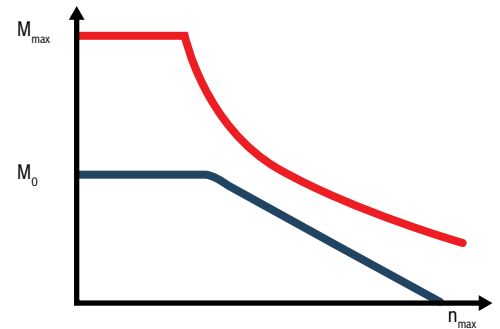

■ For more information, please visit: www.boschrexroth.com/cat-mbs

Technical specifications							
Type	Maximum speed	Standstill torque	Maximum torque	Continuous standstill current	Maximum current	Moment of inertia	
	n_{\max} min ⁻¹	M_0 Nm	M_{\max} Nm	I_0 A	I_{\max} A	J ¹⁾ kg·m ²	
MSS102B-0800	22 500	10.7	36	16.9	52	0.0030	
MSS102D-0800	22 500	20.0	45	24.0	69	0.0040	
MSS102F-0300	18 000	32.0	75	15.3	35	0.0060	
MSS102F-0800	22 500	26.0	68	43.0	100	0.0060	
MSS142B-0700	19 000	27.5	67	45.0	100	0.0110	
MSS142D-0700	19 000	40.5	90	65.0	140	0.0140	
MSS142F-0700	19 000	53.0	113	84.0	180	0.0170	
MSS162B-0400	16 500	50.0	115	42.0	110	0.0140	
MSS162D-0400	16 500	70.0	160	64.0	170	0.0180	
MSS162F-0310	15 500	90.0	200	64.0	170	0.0220	
MSS162J-0200	10 000	120.0	275	45.7	128	0.0280	
MSS182A-0100	6 000	12.0	30	3.7	11	0.0089	
MSS182A-0250	12 000	12.0	30	5.0	15	0.0089	
MSS182B-0280	12 000	100.0	230	64.0	170	0.0310	
MSS182D-0260	12 000	125.0	320	65.0	200	0.0390	
MSS182F-0200	12 000	200.0	450	71.0	200	0.0530	
MSS202A-0200	11 000	105.0	270	45.0	130	0.0500	
MSS202B-0150	8 200	141.0	353	46.0	128	0.0640	
MSS202B-0210	11 500	128.0	320	52.0	144	0.0640	
MSS202D-0170	9 300	163.0	407	53.0	147	0.0770	
MSS202D-0360	12 500	136.0	333	102.0	197	0.0770	
MSS202F-0120	6 600	194.0	484	45.9	125	0.1040	
MSS242B-0100	6 000	220.0	575	60.0	180	0.1190	
MSS242D-0070	4 200	335.0	860	47.7	180	0.1670	
MSS242F-0060	3 600	380.0	970	60.0	180	0.1930	
MSS272B-0065	3 000	400.0	900	71.0	200	0.2680	
MSS272B-0080	3 200	400.0	900	82.0	250	0.2680	
MSS272D-0050	2 200	505.0	1 200	62.0	180	0.3350	
MSS272F-0040	1 800	650.0	1 500	71.0	200	0.4030	

¹⁾ Depending on the rotor version.

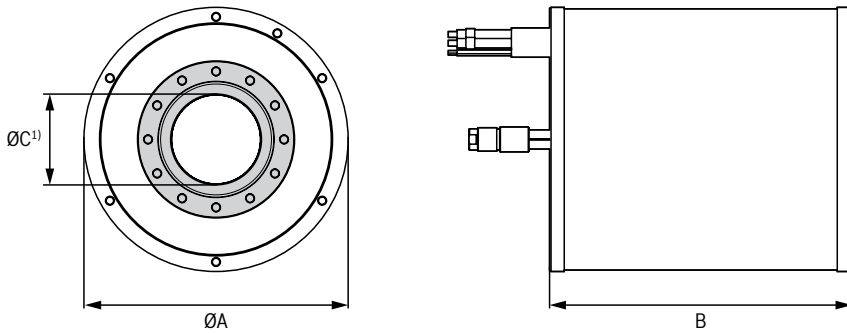

Dimensions						
Type	ØA	B	ØC ¹⁾	Mass		
				Stator	Rotor ²⁾	
	mm	mm	mm	kg	kg	
MSS102B-0800	120	156	46	5.8	2.5	
MSS102D-0800	120	206	46	7.2	4.4	
MSS102F-0300	120	306	46	11.2	5.3	
MSS102F-0800	120	306	46	11.2	5.3	
MSS142B-0700	160	181	58	9.6	5.5	
MSS142D-0700	160	231	58	16.0	7.2	
MSS142F-0700	160	281	58	21.0	8.9	
MSS162B-0400	180	206	68	22.0	6.9	
MSS162D-0400	180	256	68	28.1	8.8	
MSS162F-0310	180	306	68	28.2	10.6	
MSS162J-0200	180	381	68	46.1	13.4	
MSS182A-0100	200	82	85	6.9	2.7	
MSS182A-0250	200	82	85	6.9	2.7	
MSS182B-0280	200	232	85	32.1	9.6	
MSS182D-0260	200	282	85	38.9	11.8	
MSS182F-0200	200	382	85	43.5	16.3	
MSS202A-0200	220	215	96	25.0	12.8	
MSS202B-0150	220	265	96	40.7	16.2	
MSS202B-0210	220	265	96	40.7	16.2	
MSS202D-0170	220	315	96	37.6	19.6	
MSS202D-0360	220	315	96	37.6	19.6	
MSS202F-0120	220	415	96	63.7	26.9	
MSS242B-0100	270	275	110	66.7	22.5	
MSS242D-0070	270	375	110	92.3	31.7	
MSS242F-0060	270	425	110	105.1	36.5	
MSS272B-0065	300	330	135	90.4	35.5	
MSS272B-0080	300	330	135	90.4	35.5	
MSS272D-0050	300	405	135	112.3	44.5	
MSS272F-0040	300	480	135	134.2	53.5	

¹⁾ Depending on the rotor version.

²⁾ Rotor with largest inner rotor diameter.

MBS

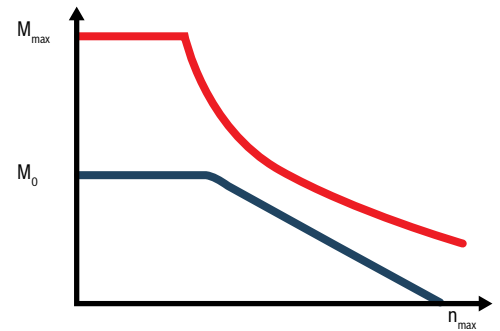

■ For more information, please visit: www.boschrexroth.com/cat-mbs

Technical specifications							
Type	Maximum speed	Standstill torque	Maximum torque	Continuous standstill current	Maximum current	Moment of inertia	
	n_{\max} min ⁻¹	M_0 Nm	M_{\max} Nm	I_0 A	I_{\max} A	J ¹⁾ kg·m ²	
MSS312B-0035	1 500	650.0	1 550	62.5	170	0.6170	
MSS312D-0028	1 200	820.0	1 950	59.5	160	0.7510	
MSS312D-0060	2 400	820.0	1 950	93.2	250	0.7510	
MSS312F-0028	1 200	975.0	2 275	62.0	180	0.8850	
MSS312H-0025	1 100	1 125.0	2 750	62.0	180	1.0640	
MSS312H-0085	3 400	1 100.0	2 750	197.0	570	1.0640	
MSS382B-0025	1 000	1 375.0	2 875	85.0	250	1.5250	
MSS382D-0020	800	1 775.0	3 700	101.0	250	1.9110	
MSS382F-0018	720	2 170.0	4 500	83.6	250	2.2960	
MSS482A-0200	4 000	120.0	240	38.6	100	0.6040	

¹⁾ Depending on the rotor version.

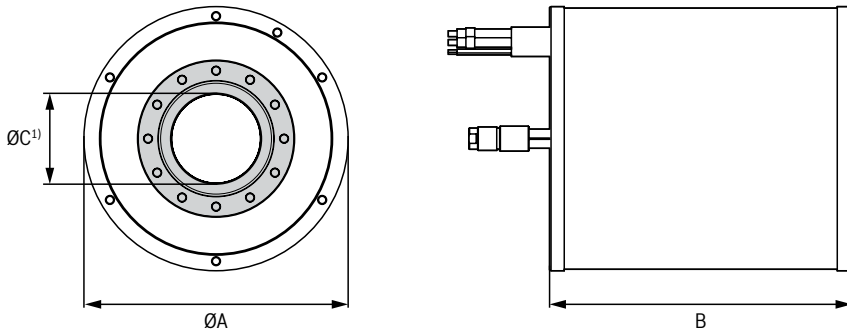
Dimensions

Type	ØA	B	ØC ¹⁾	Mass	
				Stator	Rotor ²⁾
				kg	kg
	mm	mm	mm		
MSS312B-0035	340	380	170	128.7	55.0
MSS312D-0028	340	455	170	154.1	67.4
MSS312D-0060	340	455	170	154.1	67.4
MSS312F-0028	340	530	170	179.5	79.5
MSS312H-0025	340	630	170	215.0	95.6
MSS312H-0085	340	630	170	215.0	95.6
MSS382B-0025	405	430	240	178.5	77.6
MSS382D-0020	405	530	240	247.7	97.2
MSS382F-0018	405	630	240	262.0	116.8
MSS482A-0200	115	510	345	59.0	16.2

¹⁾ Depending on the rotor version.

²⁾ Rotor with largest inner rotor diameter.

Asynchronous high-speed motor

1MB



1MB kit motors are maintenance-free asynchronous motors with high power density. Several motor sizes with different frame lengths and diameters are available for different performance requirements and installation conditions. The main spindles of modern CNC machines and complete machining centers are the main areas of application of these motors. Excellent smooth running and perfect servo quality for C-axis machining, thread cutting and spindle positioning characterize these kit motors. The asynchronous motor 1MB consists of the stator (1MS) and rotor (1MR).

- ▶ **Rated torque (M_N) up to 875 Nm**
- ▶ **Maximum speed (n_{max}) up to 20 000 min⁻¹**
- ▶ **Large spindle passage**
- ▶ **Extremely smooth running**
- ▶ **Water cooling with open cooling jacket**
- ▶ **Rotor version: Step interference fit**

Type code – stator
1MS310 B-6B-A2 /S010

Frame size

E.g. “310”

Frame length

E.g. “B”

Winding

E.g. “6B”

Special version
(is optional and not applicable in the case of standard)

E.g. PTC and NTC thermistor

Electrical connection

- 1** = Axial cable on stator side with larger outer diameter
- 2** = Axial cable on stator side with smaller outer diameter

Type code – Rotor
1MR310 B-A 094

Frame size

E.g. “310”

Frame length

E.g. “B”

Inner rotor diameter

E.g. **094** = 94 mm

Design

E.g. **A** = Step interference fit with a pressure pipe connection for disassembly

Available options and technical specifications: see project planning instructions: www.boschrexroth.com/cat-1mb

1MB

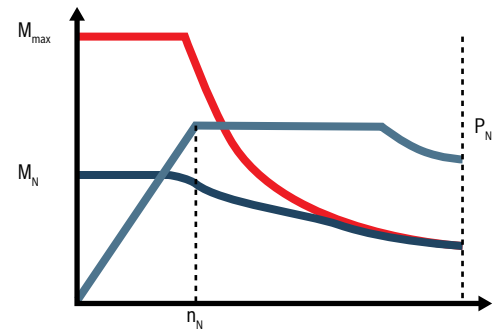

■ For more information, please visit: www.boschrexroth.com/cat-1mb

Technical specifications														
Type	Rated speed		Maximum speed		Rated torque		Rated power		Rated current		Maximum current		Moment of inertia	
	n_N	min^{-1}	n_{max}	min^{-1}	M_N	Nm	P_N	kW	I_N	A	I_{max}	A	$J^{1)}$	$\text{kg}\cdot\text{m}^2$
1MS105N-4A	4 500		15 000		15		7.0		29.0		73.68		0.0033	
1MS105N-4B	2 400		12 000		22		5.5		16.4		35.11		0.0033	
1MS140B-4A	7 500		20 000		7		5.5		18.0		41.79		0.0044	
1MS140B-4B	5 000		20 000		7		3.7		25.0		52.69		0.0044	
1MS140D-4B	4 000		16 000		14		6.0		43.0		89.37		0.0061	
1MS140F-4A	3 000		15 000		24		7.5		43.0		111.27		0.0082	
1MS140H-4B	3 000		15 000		34		10.5		58.0		127.28		0.0103	
1MS160B-4A	3 000		12 000		16		5.0		36.0		78.37		0.0084	
1MS160D-4A	3 000		12 000		32		10.0		48.0		112.83		0.0121	
1MS160D-4B	2 000		8 000		32		6.7		23.8		53.28		0.0121	
1MS160E-4B	1 000		4 000		33		3.5		19.0		34.77		0.0149	
1MS160F-4A	3 000		12 000		48		15.0		74.0		169.43		0.0161	
1MS160F-4B	3 000		12 000		48		15.0		45.0		99.87		0.0161	
1MS160F-4D	2 500		10 000		48		12.5		23.2		54.15		0.0161	
1MS160H-4A	3 000		18 000		64		20.0		58.0		132.20		0.0201	
1MS160N-4A	3 000		12 000		89		28.0		75.0		170.83		0.0267	
1MS160N-4B	2 000		8 000		89		18.6		60.0		135.51		0.0267	
1MS160N-4C	1 500		6 000		89		14.0		26.0		67.76		0.0267	
1MS200C-4A	1 500		6 000		57		9.0		50.0		114.48		0.0410	
1MS200D-4B	1 500		6 000		85		13.5		48.0		115.76		0.0370	
1MS200D-4C	5 000		20 000		59		31.0		75.0		157.18		0.0370	
1MS200D-4D	2 500		10 000		85		22.0		59.0		144.29		0.0370	
1MS200D-4E	1 500		6 000		85		13.5		84.0		201.91		0.0370	
1MS200D-4F	6 000		18 000		49		31.0		82.0		182.24		0.0370	
1MS200E-4B	1 800		7 200		85		16.0		41.4		111.08		0.0590	
1MS200E-4C	3 900		15 600		74		30.2		65.0		139.44		0.0590	
1MS200H-4B	1 500		6 000		124		19.5		68.0		171.00		0.0690	
1MS200H-4D	1 500		6 000		124		19.5		52.6		128.21		0.0690	
1MS240B-4A	1 000		4 000		62		6.5		46.0		101.06		0.0780	
1MS240F-4A	1 000		4 000		123		13.0		74.0		164.18		0.1200	
1MS240H-4B	1 000		4 000		169		18.0		56.0		124.16		0.1530	

¹⁾ Depending on the rotor version.

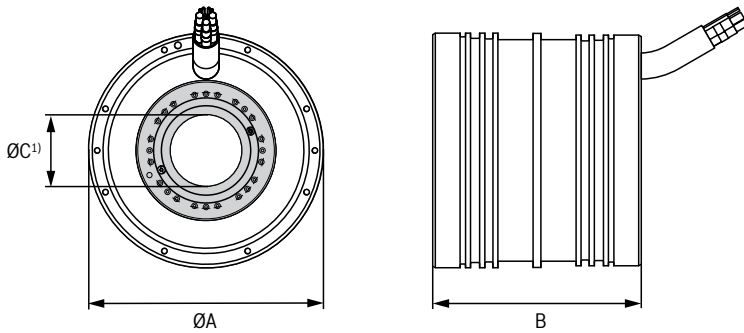
Dimensions

Type	ØA	B	ØC ¹⁾	Mass	
				Stator ²⁾	Rotor ³⁾
	mm	mm	mm	kg	kg
1MS105N-4A	120	350	40.5	11.2	2.8
1MS105N-4B	120	350	40.5	11.2	2.8
1MS140B-4A	160	150	45.0	5.3	3.3
1MS140B-4B	160	150	45.0	5.3	3.3
1MS140D-4B	160	190	45.0	8.2	4.5
1MS140F-4A	160	240	45.0	11.8	6.1
1MS140H-4B	160	290	45.0	15.5	7.3
1MS160B-4A	180	160	60.0	6.8	5.3
1MS160D-4A	180	205	60.0	11.1	7.3
1MS160D-4B	180	205	60.0	11.1	7.3
1MS160E-4B	180	240	60.0	14.4	9.4
1MS160F-4A	180	255	60.0	15.8	10.2
1MS160F-4B	180	255	60.0	15.8	10.2
1MS160F-4D	180	255	60.0	15.8	10.2
1MS160H-4A	180	310	60.0	21.0	9.8
1MS160N-4A	180	385	60.0	28.1	12.7
1MS160N-4B	180	385	60.0	28.1	12.7
1MS160N-4C	180	385	60.0	28.1	12.7
1MS200C-4A	220	240	66.0	21.0	15.0
1MS200D-4B	220	295	66.0	29.0	19.0
1MS200D-4C	220	295	66.0	29.0	19.0
1MS200D-4D	220	295	66.0	29.0	19.0
1MS200D-4E	220	295	66.0	29.0	19.0
1MS200D-4F	220	295	66.0	29.0	19.0
1MS200E-4B	220	330	66.0	34.0	22.0
1MS200E-4C	220	330	66.0	34.0	22.0
1MS200H-4B	220	380	66.0	41.0	26.0
1MS200H-4D	220	380	66.0	41.0	26.0
1MS240B-4A	270	270	87.0	29.0	19.0
1MS240F-4A	270	360	87.0	48.0	29.0
1MS240H-4B	270	430	87.0	62.0	37.0

¹⁾ Depending on the rotor version.

²⁾ Stator for version with open cooling jacket.

³⁾ Rotor with largest inner rotor diameter.

1MB

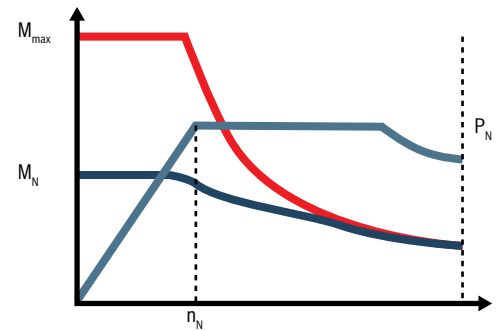

■ For more information, please visit: www.boschrexroth.com/cat-1mb

Technical specifications														
Type	Rated speed		Maximum speed		Rated torque		Rated power		Rated current		Maximum current		Moment of inertia	
	n_N	min^{-1}	n_{max}	min^{-1}	M_N	Nm	P_N	kW	I_N	A	I_{max}	A	J ¹⁾	$\text{kg}\cdot\text{m}^2$
1MS241D-6A	2 400		6 000		100		25.1		57.0		139.52		0.1350	
1MS241D-6C	1 000		4 000		112		12.0		27.0		59.68		0.1350	
1MS241H-6C	1 800		7 200		202		32.0		75.5		184.55		0.2270	
1MS241H-6D	850		3 400		202		18.0		66.4		127.88		0.2270	
1MS241H-6G	800		3 200		202		16.9		39.7		91.92		0.2270	
1MS242N-4B	1 700		6 800		185		33.0		98.0		224.31		0.1350	
1MS270C-4B	1 500		6 000		190		30.0		96.0		228.50		0.2580	
1MS310B-6B	700		2 800		260		19.0		75.0		164.03		0.4770	
1MS310B-6D	1 000		4 000		260		27.0		81.0		178.92		0.4770	
1MS310B-6E	440		1 760		260		12.0		58.0		125.75		0.4770	
1MS310D-6B	800		3 200		340		28.5		81.0		174.17		0.4920	
1MS310F-6A	400		1 600		480		20.0		63.8		138.75		0.7230	
1MS310F-6B	900		3 600		480		45.2		111.0		246.64		0.7230	
1MS375B-6B	600		2 400		636		40.0		120.0		257.22		1.3900	
1MS375D-6B	600		2 400		875		55.0		150.0		329.29		1.7300	
1MS375D-6D	300		1 200		875		27.5		94.0		210.01		1.7300	

¹⁾ Depending on the rotor version.

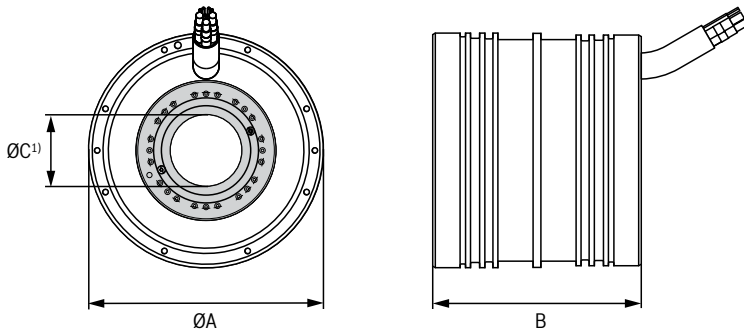
Dimensions

Type	ØA	B	ØC ¹⁾	Mass	
				Stator ²⁾	Rotor ³⁾
	mm	mm	mm	kg	kg
1MS241D-6A	270	290	111.0	38.0	24.0
1MS241D-6C	270	290	111.0	38.0	24.0
1MS241H-6C	270	410	111.0	63.0	39.0
1MS241H-6D	270	410	111.0	63.0	39.0
1MS241H-6G	270	410	111.0	63.0	39.0
1MS242N-4B	270	440	71.0	81.0	37.0
1MS270C-4B	300	400	120.0	82.0	52.0
1MS310B-6B	340	385	125.0	84.0	65.0
1MS310B-6D	340	385	125.0	84.0	65.0
1MS310B-6E	340	385	125.0	84.0	65.0
1MS310D-6B	340	450	125.0	108.0	80.0
1MS310F-6A	340	520	125.0	133.0	97.0
1MS310F-6B	340	520	125.0	133.0	97.0
1MS375B-6B	405	520	170.0	162.0	106.0
1MS375D-6B	405	620	170.0	205.0	132.0
1MS375D-6D	405	620	170.0	205.0	132.0

¹⁾ Depending on the rotor version.

²⁾ Stator for version with open cooling jacket.

³⁾ Rotor with largest inner rotor diameter.

ENGINEERING SOFTWARE

The background is a vibrant blue with a complex, abstract geometric pattern. It features several overlapping, semi-transparent planes and lines that create a sense of depth and movement, reminiscent of a modern architectural design or a digital interface. The lighting is soft, highlighting the edges of the planes and creating a gradient of blue tones from a lighter cyan at the top to a deeper blue at the bottom.

5	IndraWorks Engineering	374
	IndraWorks WinStudio	384
	IndraWorks SafetyManager	386
	IndraWorks WebComposer	387
	IndraSize	388

Engineering software

The IndraWorks Engineering Framework is the central software tool for efficient project planning, programming, commissioning and diagnosis of a wide variety of applications over the entire product lifecycle of a machine. Function toolkits expand the functionality of the standard PLC engineering framework IndraWorks with technology-based solutions.

These function packages accelerate the implementation of complex machine processes, optimize the project workflow in machine manufacturing through additional engineering interfaces or increase productivity through homogeneous integration of extended machine functionality.

- ▶ **Uniform engineering framework for project planning, programming, parameterization, commissioning and service**
- ▶ **Future-proof automation thanks to open standards**
- ▶ **Easy and integrated operation of all software tools**



- ▶ **IndraWorks Engineering**
IndraWorks Engineering for the efficient project planning, programming, commissioning and diagnosis



- ▶ **IndraWorks WinStudio**
WinStudio is the high-performance visualization module for consistent engineering



5

► **IndraSize**

IndraSize is the dimensioning software for all electrical Bosch Rexroth drives



► **IndraWorks SafetyManager**

With the SafetyManager, the safety control, integrated with standard components, can be put into operation quickly and efficiently. The SafetyManager Lite variant enables simple diagnostics by means of read access for checking and remote maintenance.



► **IndraWorks WebComposer**

WebComposer for convenient and efficient engineering for web applications

IndraWorks Engineering



IndraWorks Engineering solves all tasks of PLC-based automation and drive commissioning in a uniform and intuitively operable software environment. All necessary basic tools, including the homogeneously integrated CoDeSys V3, are available throughout. Users benefit from fast and transparent access to all functions and system data of the automation components. IndraWorks Engineering offers integrated operation based on current Windows technologies and extensive wizards for project planning of controls, drives and peripherals.

Function toolkits expand the standard feature of IndraWorks Engineering with technology-oriented solutions. These function packages accelerate the implementation of complex machine processes, optimize the project workflow in machine manufacturing through additional engineering interfaces or increase productivity through homogeneous integration of extended machine functionality.

- ▶ **PLC, CNC and motion control programming based on CoDeSys V3 with object-oriented language extensions**
- ▶ **Intelligent, wizard-supported operation**
- ▶ **Comprehensive software libraries according to IEC 61131-3 and PLCopen**
- ▶ **Standardized interfaces such as TCI (Tool Callback Interface) from version control systems and automation interface**
- ▶ **Detailed diagnoses**

■ For more information, please visit: www.boschrexroth.com/cat-iworks-e

Technical specifications		IndraDrive	MTX	MLC	MLD	ILC
System software						
IndraWorks variant						
IndraWorks ML		●	–	●	●	●
IndraWorks MTX		●	●	–	●	●
IndraWorks MLD		●	–	–	●	–
IndraWorks Ds		●	–	–	–	–
Basic functions						
Operating system support	Windows XP	●	●	●	●	●
	Windows 7	●	●	●	●	●
	Windows 10	●	●	●	●	●
Multilingual framework		●	●	●	●	●
Multilingual projects		–	●	●	●	●
Export/import texts of PLC projects		–	●	●	●	●
Firmware administration		●	●	●	●	●
Deactivation/parking of drives in the project		●	●	●	●	●
Automatic recognition of drives and I/O		●	●	●	●	●
Online/offline switching		●	●	●	●	●
Automatic system monitoring	Display of messages and errors	–	●	●	●	●
Project comparison		–	●	●	●	●
Online change		–	●	●	●	●
Find/replace		–	●	●	●	●
Cross references		–	●	●	●	●
Call tree		●	●	●	●	●
Logbook		●	●	●	●	●
Integration of 3rd party commissioning tools via TCI		–	●	●	●	●
Automatic configuration						
Automation Interface		Open programming interface for automated configuration of IndraWorks Engineering projects. With the help of VBA, .Net or JavaScript, new projects and configurations are created or recurring activities are automated. This increases software quality while simultaneously saving time.				
		●	●	●	●	●

● Standard ○ Option

IndraWorks Engineering

■ For more information, please visit: www.boschrexroth.com/cat-iworks-e

Technical specifications						
System software		IndraDrive	MTX	MLC	MLD	ILC
Version control (VCS)						
Team Engineering		Allows for the connection of an IndraWorks Engineering project with a version control system. In this way, the engineering project can be versioned and processed by one or more users in parallel. To this end, IndraWorks supports the "Subversion" VCS system that provides the project management with central data management. The IndraWorks option VCS client includes an extensive set of commands such as compare, update, merge, analyze and report. This allows for easy tracking of the project history, a detailed project comparison or the restoration of an older project status.				
VCS system "Subversion"		–	●	●	–	●
Check-in/check-out of objects		–	●	●	–	●
Hijack of objects		–	●	●	–	●
Object comparison	Unit, POE, function module, library, visualization	–	●	●	–	●
Undo functions		–	●	●	–	●
Update working copy		–	●	●	–	●
Display version history		–	●	●	–	●
Show versioned elements		–	●	●	–	●
Configuration and project planning						
System configurator		–	●	●	●	●
Device library for controls, visualization, peripherals		●	●	●	●	●
Commissioning wizards		●	●	●	●	●
Project navigator		●	●	●	●	●
I/O configuration		●	●	●	●	●
Fieldbus configuration		●	●	●	●	●
Axis configuration	Real axes	●	●	●	●	●
	Virtual axes	–	●	●	●	●
	Encoder axes	–	–	●	●	●
	Network axes	–	–	●	●	–
	Control axes	–	–	●	–	–

Technical specifications		IndraDrive	MTX	MLC	MLD	ILC
System software						
Configuration and project planning						
Drive configuration		●	●	●	●	●
Project archiving		●	●	●	●	●
Parameter monitoring of controls and drives		●	●	●	●	●
Offline parameterization of controls and drives		●	●	●	●	●
Kinematics (robot control)	Configuration of standard kinematics	–	–	●	–	–
	Definition of user-specific kinematics	–	–	●	–	–
	Integrated RCL editor	–	–	●	–	–
Extended project handling		●	●	●	●	●
Creation of motion profiles						
FlexProfile		For the implementation of complex, non-linear motion control, FlexProfile replaces time-consuming programming with simple parameterization. Motion profiles are graphically created from a library of over 20 motion sets using the CamBuilder toolbox integrated in IndraWorks Engineering. Individual segments are interlinked to form a profile via a large number of motion sets and transition conditions. For detailed analysis, the engineering software simulates several profiles with display of position, speed and acceleration values. At the press of a button, the profile parameters are loaded into the control and the PLC function module is generated for integration into the application program.				
CamBuilder cam editor		○	–	○	○	○
PLC programming						
Graphical editors						
Sequential function chart (SFC)		–	●	●	●	●
Time monitoring per step		–	●	●	●	●
Error analysis		–	●	●	●	●
Control flags		–	●	●	●	●
Ladder diagram (LD)		–	●	●	●	●
Function plan (FUP)		–	●	●	●	●
Free graphical function chart (CFC)	Connection autorouting	–	●	●	●	●
	Macro for structuring large networks	–	●	●	●	●

● Standard ○ Option

IndraWorks Engineering

■ For more information, please visit: www.boschrexroth.com/cat-iworks-e

Technical specifications						
System software		IndraDrive	MTX	MLC	MLD	ILC
PLC programming						
Text editors						
Instruction list (IL)		–	●	●	●	●
Structured text (ST)		–	●	●	●	●
Sequential programming in ST code		–	–	●	–	–
Robot Control Language (RCL)		–	–	●	–	–
Language elements						
Operators	As per IEC 61131-3	–	●	●	●	●
Operands	Constants, variables, addresses, functions	–	●	●	●	●
Bit access		–	●	●	●	●
Typed pointers		–	●	●	●	●
Object-oriented language extensions		–	●	●	●	●
Data types						
Standard as per IEC 61131-3		Incl. LREAL	–	●	●	●
User-defined		Arrays, structures, enumeration, alias, pointer	–	●	●	●
Robot Control		POINT, JC_POINT, BELT, TEXT, ARRAY, WC_FRAME, FILE	–	–	●	–
Special editor features						
Syntax coloring		–	●	●	●	●
Semantic coloring		–	●	●	●	●
Multiple undo/redo		–	●	●	●	●
Context-sensitive input assistance		–	●	●	●	●
Context menus		–	●	●	●	●
Auto-declaration with type recognition		–	●	●	●	●
Name spaces		–	●	●	●	●
Auto complete (IntelliSense)		For structures, functions, function modules	–	●	●	●

Technical specifications		IndraDrive	MTX	MLC	MLD	ILC
System software						
PLC programming						
Special editor features						
Precompile	For constant syntax check	–	●	●	●	●
Folding	Show/hide program blocks and structures	–	●	●	●	●
Advanced search and replace		–	●	●	●	●
Smart-coding	Auto complete and auto format	–	●	●	●	●
Library administration						
License management		–	●	●	▼	●
Managed libraries	Multiple library versions in a project	–	●	●	▼	●
Libraries (selection)						
Basic libraries	System functions	–	●	●	●	●
	Communication	–	●	●	●	●
	PLCopen	–	●	●	●	●
	Data handling	–	●	●	●	●
	Diagnosis	–	●	●	●	●
	Axis interface	–	●	●	●	●
Technology libraries	Kinematics	–	–	●	–	●
	Gantry axes	–	–	●	○	●
	Probe evaluation	–	–	●	●	●
	Programmable limit switch	–	–	●	–	●
	PID control	–	–	●	▼	●
	Temperature control	–	–	●	▼	●
	Hydraulic functions	–	–	●	–	–

● Standard ○ Option ▼ In preparation

IndraWorks Engineering

■ For more information, please visit: www.boschrexroth.com/cat-iworks-e

Technical specifications		IndraDrive	MTX	MLC	MLD	ILC
System software						
PLC programming						
Libraries (selection)						
Technology libraries (industries)	Register control Basic	–	–	●	○	–
	Register control Advanced	–	–	○	○	–
	Register control Extended	–	–	○	–	–
	Tension control – 1 axis	–	–	●	○	–
	Tension control – 8 axes	–	–	○	–	–
	Cross cutters	–	–	●	○	–
	Loop control	–	–	●	–	–
	Flying shear	–	–	●	○	–
	Smart Belt/Magic Belt	–	–	●	○	–
	Magic Belt	–	–	●	–	–
	Crank/bell-crank kinematics	–	–	●	○	–
	Winder and dancer control	–	–	●	○	–
Programming assistants						
	Offline programming	–	●	●	●	●
	Automatic variables declaration of the system components	–	●	●	●	●
	Structures of axis data	–	●	●	●	●
AXIS_REF	Reference to axis data	–	●	●	●	●
ML_AXISDATA	Direct access to axis data	–	–	●	●	●
Generic Application Template						
Automatic code generation	Program structure	–	–	●	●	●
	Error handling	–	–	●	●	●
	Separation of program framework and user code possible	–	–	●	–	–
Wizard-supported creation, editing, deletion of	Operation modes	–	–	●	●	●
	Operating status	–	–	●	●	●
	Modules	–	–	●	●	–
	Axes	–	–	●	●	●
	Visualization	–	–	●	–	●

Technical specifications		IndraDrive	MTX	MLC	MLD	ILC
System software						
Online debugging and commissioning						
Diagnosis						
Real-time logic analyzer		–	●	●	●	●
Oscilloscope function	Graphic output with zoom function	●	●	●	●	●
	Display of the signal values of drives	●	●	●	●	●
	Scaling	●	●	●	●	●
	Measurement with/without trigger	●	●	●	●	●
Circular shape test	–	●	–	–	–	
NC analyzer	–	●	–	–	–	
Action recorder MTX acr	–	●	–	–	–	
Cycle time analysis MTX cta	–	●	–	–	–	
Debugging						
Monitoring of variables	Trace	●	●	●	●	●
Forcing variables and variable sets		●	●	●	●	●
Power flow	Sequence monitoring	–	●	●	●	●
Online exchange of function modules		–	●	●	●	●
Offline simulation of PLC variables		–	●	●	●	●
Parameter monitor		●	●	●	●	●
Writing variables		●	●	●	●	●
Breakpoint		–	●	●	●	●
Single step operation mode		–	●	●	●	●
Single cycle operation		–	●	●	●	●
Flow control		–	●	●	●	●
HMI project planning						
WinStudio Lite ¹⁾		–	●	●	–	●
WinStudio ¹⁾		–	○	○	○	○
WebComposer ²⁾		–	–	●	–	●

● Standard ○ Option

¹⁾ See “IndraWorks WinStudio” on page 384

²⁾ See “IndraWorks WebComposer” on page 387

IndraWorks Engineering

■ For more information, please visit: www.boschrexroth.com/cat-iworks-e

Technical specifications						
System software		IndraDrive	MTX	MLC	MLD	ILC
Simulation						
Software MTX workstation	PLC emulation	–	●	–	–	–
	CNC emulation	–	●	–	–	–
Machine and machining simulation for milling, drilling, jet cutting ³⁾	Representation of tools, work piece and material processing	–	●	–	–	–
	3D machine models, incl. collision detection	–	○	–	–	–
Simulation with 3rd party software tools	via Open Core Interface	–	–	○	–	○
Safety project planning						
SafetyManager ⁴⁾		–	○	○	–	○

● Standard ○ Option

³⁾ See “MTX Virtual Machine Simulation” and “MTX Virtual Machine Builder” from page 30

⁴⁾ See “IndraWorks SafetyManager” on page 386

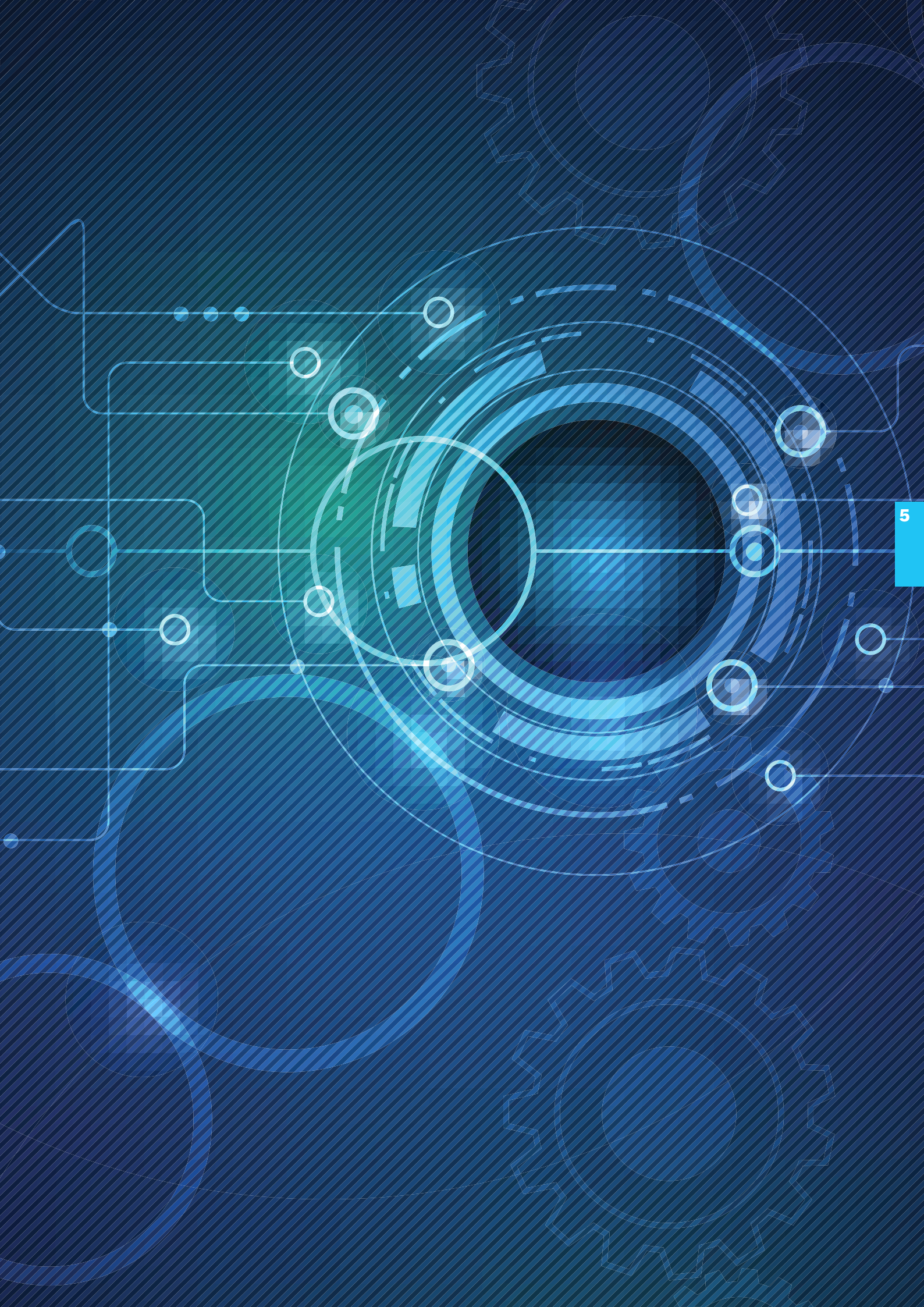

IndraWorks WinStudio

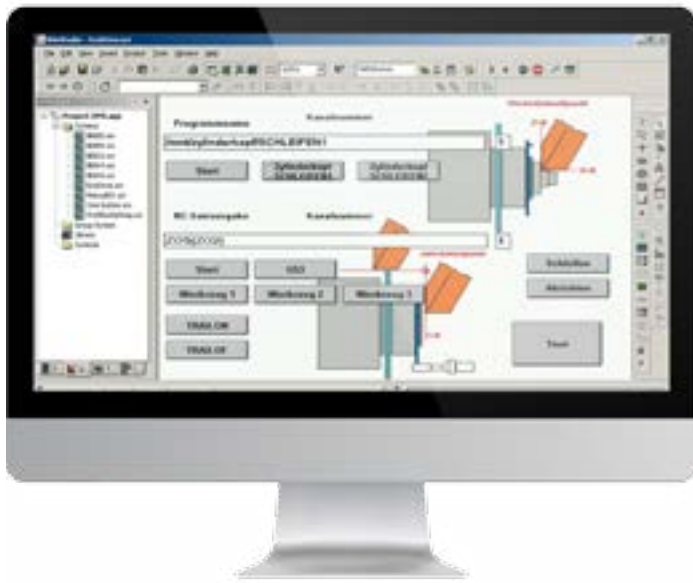

WinStudio is the high-performance visualization module in IndraWorks for consistent engineering and user-friendly operation.

With WinStudio, individual applications are created quickly, easily and efficiently with only one tool. The use of WinStudio together with the PC based solutions from Bosch Rexroth ensures maximum functionality and performance.

The flexible licensing model differentiates between development and runtime versions. Using a development version you can customize applications as often as you want and use different runtime versions. This approach enables optimal machine adaptation to the relevant conditions while ensuring maximum profitability.

- ▶ **Easy project planning of the system visualization**
- ▶ **Clear selection of objects by using the Project Explorer**
- ▶ **Project planning without the need for high-level language skills**
- ▶ **Simple process data import via tag wizard**
- ▶ **One tool for all Windows-based HMI devices from Bosch Rexroth**

■ For more information, please visit: www.boschrexroth.com/cat-winstudio

Technical specifications									
Type	WinStudio lite		WinStudio 0.5 k	WinStudio 1.5 k		WinStudio 4 k	WinStudio 16 K	WinStudio 64 K	WinStudio 512 k
Runtime license for operating system	WES7, Win10	WEC7	WEC7	WES7, Win10	WEC7	WES7, Win10	WES7, Win10	WES7, Win10	WES7, Win10
Development license for operating system	Win7/WES7, Win 8, Win10	–	–	Win7/WES7, Win 8, Win10	–	Win7/WES7, Win 8, Win10	Win7/WES7, Win 8, Win10	Win7/WES7, Win 8, Win10	Win7/WES7, Win 8, Win10
Number of variables	≤ 500	≤ 500	≤ 500	≤ 1 500	≤ 1 500	≤ 4 000	≤ 16 000	≤ 64 000	≤ 512 000
.NET Controls	●	–	–	●	–	●	●	●	●
ODBC	●	–	–	●	–	●	●	●	●
Mathematics	●	●	●	●	●	●	●	●	●
Alarm and event messages	–	–	●	●	●	●	●	●	●
History	–	–	●	●	●	●	●	●	●
Drivers	1	1	3	3	3	5	5	8	8
OPC server	–	–	●	●	●	●	●	●	●
OPC client	●	●	●	●	●	●	●	●	●
TCP/IP server	●	●	●	●	●	●	●	●	●
TCP/IP client	–	–	●	●	●	●	●	●	●
OPC UA client	●	●	●	●	●	●	●	●	●
Tag database	●	●	●	●	●	●	●	●	●
Web client	–	–	–	1/4/8	–	1/4/8	1/4/8	1/4/8	1/4/8
Recipe handling (UNICODE, XML)	–	–	●	●	●	●	●	●	●

● Standard ○ Option

IndraWorks SafetyManager



The safety application of the certified SafeLogic safety control is created simply and safely with the SafetyManager. Programming is carried out according to the principles of the PLCopen Safety specification. The programming is designed in analogy to the wiring of discrete safety switchgears. The switchgear is replaced by certified function modules and the discrete wiring is replaced by the graphic connections (programming) of the function blocks.

The SafetyManager contains everything for:

- ▶ Project planning
- ▶ Parameterization
- ▶ Programming the safety project
- ▶ Use of function module libraries (e.g. to control the SafeMotion or for press applications)

Fully integrated into the standard engineering tool:

- ▶ Same look-and-feel
- ▶ Integrated diagnostics concept
- ▶ Access to all safety I/Os also from the standard control system

Safety integrity systematically integrated in the tool:

- ▶ User manager
- ▶ PLCopen Safety conformity
- ▶ Certified libraries
- ▶ Efficient and clear due to axis group formation

Application-specific licensing variants:

- ▶ Full version of SafetyManager for application development
- ▶ Read-only SafetyManager Lite for service and remote access

■ For more information, please visit: www.boschrexroth.com/cat-sl

Technical specifications		
Type		SafetyManager
Programming	IndraWorks Engineering	●
Programming language	Function block diagram programming in accordance with IEC 61131-3	●
Language scope	Basic/extended mode as per PLCopen Safety	●
Data types	Standard, Safety	●
Library functions Standard	E.g. SF_RS, SF_SR, SF_CTD, SF_CTU, SF_TOF, SF_TON	●
Library functions PLCopen	E.g. SF_EmergencyStop, SF_EnableSwitch, SF_GuardLocking, SF_GuardMonitoring, SF_AxisGroup	●
Data exchange between standard and safety application		●

● Standard ○ Option

IndraWorks WebComposer



WebComposer allows for the convenient and efficient engineering of web applications without any knowledge of the underlying web technology. Comprehensive widget libraries offer ready-made elements such as text fields, buttons, sliders, progress displays or tachometers. These are placed on the website using drag-and-drop.

- ▶ **HTML5-based creation of device-independent visualization interfaces**
- ▶ **Integrated in IndraWorks Engineering, including online image preview and process connection**
- ▶ **Direct process data access to all Rexroth automation components**
- ▶ **Creation of commissioning interfaces (component of the IndraWorks Engineering license)**
- ▶ **Creation of specific websites for WebAssistant (software option)**
- ▶ **JavaScript for dynamic user interface adaptation**

■ For more information, please visit: www.boschrexroth.com/cat-webcomposer

Technical specifications		
Type		WebComposer
Web editor	Integrated in IndraWorks Engineering	●
Creation of web applications	Commissioning interfaces	●
	Webpages for WebAssistant (MLC/ILC)	○
Integrated web server	Online representation in the project planning environment	●
Communication protocol	OPC UA	●
	Open Core Interface for controls	●
Underlying web technologies	HTML5	●
	JavaScript	●

● Standard ○ Option

IndraSize

Dimensioning software for drive design



The IndraSize dimensioning software makes it easier for Bosch Rexroth to ensure the optimal dimensioning of drive control units and motors. The user-friendly interface takes only a few minutes to enter the dimensions of all common drive mechanisms, e.g. for:

- ▶ Ball screw drive
- ▶ Rack and pinion
- ▶ Belt and pulley
- ▶ Linear direct drive
- ▶ Rotary drive
- ▶ Roller
- ▶ Rotary knife
- ▶ Winder mechanism
- ▶ Roll feed

■ For detailed information, please visit:
www.boschrexroth.com/indrasize

Standard motion sequences (rotary or linear) can be freely configured by means of the specification of the kinematics data and the selection of the motion law.

If the motion sequence is not known exactly, dimensioning can be determined by means of the relative duty cycle.

Cam disks can be imported from IndraWorks Engineering for very complex motion sequences.

In addition, IndraSize offers the possibility of describing the motion profiles of typical applications in a very simple form using parameter input. In this way, optimum drive solutions can be configured for different applications, e.g. for:

- ▶ Winder
- ▶ Flying cutoff
- ▶ Roll feed
- ▶ Cross cutters

The direct input or import of torque, force or power load also allows for the integration of data from measurements or from own calculations.

For quick drive selection, there is also the easy way to display characteristic curves of the motor-control combinations directly or to make a preliminary selection via torque and speed specifications.

The IndraSize design software and thermal monitoring in the control software are based on the same algorithms. This enables safe operation at all operating points.

IndraSize

Dimensioning software for drive design

Thermally and dynamically optimized drive design in 5 steps, for a specified process.

1

Select the application



Selection of rotary or linear drive, output element, type of motion profile, application-specific mechanics and motion profiles, simple backlash definitions

2

Input of mechanical data



Data of the output and transfer elements, masses, forces, inertia, torques, friction, axis slope, weight compensation...

3

Input of motion data



Freely configurable standard profiles, polynomial functions, jerk limitation, application-specific motion sequences, read-in of cams...

4

Drive selection



Selection according to motor type, type of cooling, converter type, supply type, supply voltage, tolerances...

5

Detailed view and saving

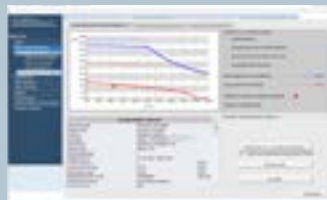

Diagram with work points, power loss, levels of efficiency, thermal load, typical variables of the drive and application...

Direct drive selection in 3 steps, for fast selection of a drive/motor based on basic parameters**1****Specification of work points**

Specification of torque and speed and/or force and velocity values for testing against the reference characteristic curve of the drive without time analysis

2**Drive selection**

Preselection according to motor type, size, type of cooling, converter type, supply type, supply voltage, tolerances...

3**Detailed view and saving**

Diagram with work points, power loss, levels of efficiency, typical drive sizes

PROCESS CONTROL SYSTEMS

6	Welding control system PRC	396
	Operating software PRI	399
	Welding transformers PSG	400
	System components	
	GDM, MGDM	402

Process control systems

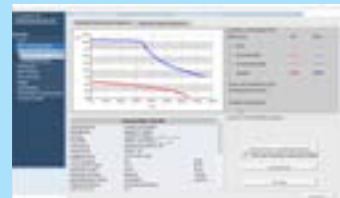
Welding processes in the automotive and home industries require ultra-high process reliability and quality. The Rexroth PRC 7000 welding control systems and the PSG 6000 welding transformers are far more than a tried-and-tested control and monitoring solution. Users benefit from fast commissioning, maximum availability and energy efficiency, simple operation and maximum flexibility.

- ▶ **System supplier for inverter controls, welding transformers, servo drives, gun data modules and safety technology**
- ▶ **Up to 90 % faster commissioning compared to conventional technology**
- ▶ **Ultra-high spot weld quality thanks to adaptive control for all welding tasks**
- ▶ **More than 80 % of the automotive manufacturers trust in process control systems by Bosch Rexroth**



▶ **Welding control system PRC**

Flexibly configurable hardware: two power classes, two supply voltage ranges, each with air and water cooling available.



▶ **Operating Software PRI**

User-friendly software with intuitive operating interface.



► **Welding transformers**

PSG

Compact power packs in nine performance classes, for manual welding guns, robotic guns and welding machines.



► **System components**

Gun Data Modules for storing welding gun data, measured value acquisition and pre-processing.

Welding control system

PRC



With adaptive control algorithms, the new PRC 7000 welding control system creates the ideal conditions for reproducibly high welding quality. Up to 10 000 welding tasks for different sheet thicknesses and materials from steel to aluminum can be programmed. Thanks to the exact adaptation of the welding current, welding spatter and cost-intensive rework can be effectively avoided. Already today, the operating, process control and monitoring functions are designed for all future requirements for welding processes.

- ▶ **Ultra-high spot weld quality thanks to optimized programming, control and monitoring functions**
- ▶ **Maximum energy efficiency thanks to state-of-the-art power electronics**
- ▶ **Open system architecture with integrated application layer and servo gun functions**
- ▶ **Flexibly configurable hardware with regard to power, cooling, communication and I/O connection**

Type code

PRC7300-L 1-01VRS-0300-01-00001-CC-00

Power class

300 = Max. welding current ¹⁾ 33 kA
400 = Max. welding current ¹⁾ 80 kA

Cooling

L = Air cooling
W = Water cooling

Supply voltage range

1 = 400 ... 480 V (-15/+10 %)
2 = 500 ... 690 V (-15/+10 %)

Version

CC = Unpacked
ST = Packaged

Function ID

E.g. 0300, 0401
 see type-specific instructions

¹⁾ Maximum secondary current of the welding transformer at a transmission ratio of 55:1 (supply voltage range = 1) or 72:1 (mains voltage range = 2)
 Available options and technical specifications: see project planning instructions: www.boschrexroth.com/mediadirectory

■ For more information, please visit: www.boschrexroth.com/welding

Functions				
Type	PRC 7x00-x1-01VRS-0300-...	PRC 7x00-x1-01VRS-0401-...	PRC 7x00-x1-01VRS-0402-...	PRC 7x00-x1-01VRS-0403-...
Purpose of use				
Control for manual welding guns	–	–	●	–
Control for pneumatic robot guns	●	–	–	●
Control for servo-electric robot guns	–	●	–	–
Fieldbus module ¹⁾				
PROFINET	●	●	–	–
EtherNet/IP	–	–	–	●
Discrete inputs/outputs ²⁾				
Inputs (control ¹⁾)	–	10	14	4
Inputs (extendible ³⁾)	–	8	24	–
Outputs (control ¹⁾)	–	6	8	4
Outputs (extendible ³⁾)	–	15	54	–
Analog inputs/outputs				
Inputs (control ¹⁾)	2	4	2	4
Inputs (extendible ³⁾)	–	–	2	–
Outputs (control ¹⁾)	–	1	1	1
Outputs (extendible ³⁾)	–	–	2	–
Special features				
Status codes via fieldbus	–	●	–	●
Functions: Gun service life, tip wear, visualization of the electrode status, protocol of workpiece number	●	–	–	–
Functions: Servo gun electrical, dresser management	–	●	–	–
Functions: Electrode management 2 guns, outputs for displays status and program selection	–	–	●	–

● Included in the scope of delivery

– not included

¹⁾ Included in the control

²⁾ Actually used inputs/outputs, except for the transformer temperature, digital pressure feedback and main circuit breaker tip

³⁾ Input/output signals can be expanded via bus coupler and I/O modules and/or gun data module MGDM. Functions, I/O signal mapping and the specific characteristics of the control types are described in the respective type-specific instructions.

Welding control system

PRC

■ For more information, please visit: www.boschrexroth.com/welding

Technical specifications									
Type		PRC 7300-L1-...	PRC 7300-W1-...	PRC 7300-L2-...	PRC 7300-W2-...	PRC 7400-L1-...	PRC 7400-W1-...	PRC 7400-L2-...	PRC 7400-W2-...
Type of cooling		Air-cooled	Water-cooled	Air-cooled	Water-cooled	Air-cooled	Water-cooled	Air-cooled	Water-cooled
Power data									
Supply voltage range	V	400 ... 480	400 ... 480	500 ... 690	500 ... 690 ¹⁾	400 ... 480	400 ... 480	500 ... 690	500 ... 690 ¹⁾
Rated mains current (max. thermal continuous current)	A	110	110	80	80	250	250	180	180
Output frequency	Hz	1 000	1 000	1 000	1 000	1 000	1 000	1 000	1 000
Max. primary current (output current to the transformer)	A	550	550	420	420	1 600	1 600	1 110	1 110

¹⁾ PRC 7xxx-W2 in the IT network: 500 ... 580 V

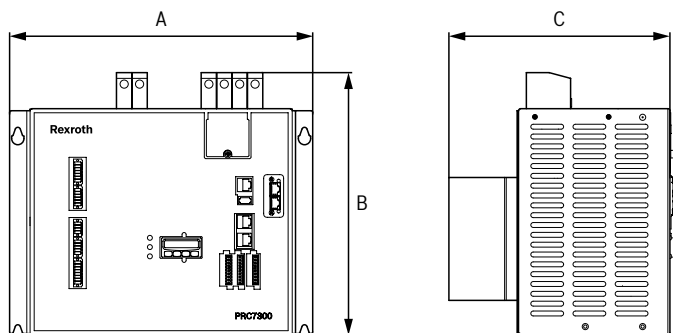

Dimensions									
Type		PRC 7300-L1-...	PRC 7300-W1-...	PRC 7300-L2-...	PRC 7300-W2-...	PRC 7400-L1-...	PRC 7400-W1-...	PRC 7400-L2-...	PRC 7400-W2-...
A	mm	370	370	370	370	385	385	385	385
B	mm	320	320	320	320	496	496	496	496
C	mm	270	237	270	237	262	250	262	250
Mass	kg	13.8	13.1	13.8	13.1	30.8	28.1	30.8	28.1

Operating software

PRI



The PRI 7000 software is used to program, operate and diagnose Rexroth welding control systems PRC 7000. Up to 100 networked Rexroth welding control systems can be operated from one workstation at the same time.

- ▶ The welding process is universally configurable, i.e. each of the over 10 000 welding tasks can be build from up to ten sequence blocks with own current profile
- ▶ The regulation mode can be set separately for each current time
- ▶ For each sequence block, current and other monitoring functions can be selected individually
- ▶ For each welding control system, measurement of current and electrode force can be scaled to an external reference measuring device.
- ▶ For each connected welding gun, the power adjustment for electrode wear, tip dressing, a force profile for each sequence block and an individual power correction can be set.
- ▶ The software offers extensive protocol functions

according to ISO 9000, such as protocols for current values, errors, events, data changes, electrode and milling cutter exchanges.

- ▶ Depending on the requirements, certain events can be defined as “error” or “warning”
- ▶ The operating interface offers an overview of all Rexroth welding control systems by means of system diagrams, a control-related overview with different filter criteria and a status display of all input/output signals of the welding control systems
- ▶ The data can be saved and restored via backup/auto backup and restore function
- ▶ Programming is possible online or offline

Welding transformers

PSG



The medium-frequency transformers of the PSG series are optimized for improved performance and efficiency in resistance welding. They are characterized by a particularly compact design and low weight. The perfectly coordinated components enable optimal power transfer as well as additional monitoring functions between converters and transformer.

- ▶ **Nine power classes from 94 ... 250 kVA (20 % duty cycle)**
- ▶ **Output DC voltage 9.0 or 14.0 V**
- ▶ **Supply voltage designed for 400 ... 690 V**
- ▶ **Different versions of power and signal connectors**

Type code	
PSG 6130.00 P ST K	
Power class E.g. 130 = 130 kVA/20 % duty cycle (OT)	Special design See type-specific instructions
Version 00, 01, 02 ... 68 See type-specific instructions	Sensors S = With secondary current sensor T = With temperature monitoring
Primary connection A = Without primary power and signal connector P = With primary power connector TAG R = With primary power connector Robifix	

Available options and technical specifications: see project planning instructions: www.boschrexroth.com/mediadirectory

■ For more information, please visit: www.boschrexroth.com/welding

Technical specifications										
Type		PSG 3075 ...	PSG 3100 ...	PSG 6120 ...	PSG 6130 ...	PSG 6160 ...	PSG 6170 ...	PSG 6180 ...	PSG 6230 ...	PSG 6250 ...
Frequency	Hz	1 000	1 000	1 000	1 000	1 000	1 000	1 000	1 000	1 000
Nominal power (20 % duty cycle)	kVA	94	145	129	140	173	172	178	237	250
Secondary voltage class	V	9.0	9.3	9.0	9.0	9.0	9.0	14.0	14.0	14.0
Continuous output current (100 % duty cycle)	kA	5.0	6.5	6.0	6.5	8.5	8.0	5.7	8.2	8.0
Output current (20 % duty cycle)	kA	11.1	14.5	13.4	14.5	19.0	17.9	12.7	18.3	17.9

Dimensions										
Type		PSG 3075 ...	PSG 3100 ...	PSG 6120 ...	PSG 6130 ...	PSG 6160 ...	PSG 6170 ...	PSG 6180 ...	PSG 6230 ...	PSG 6250 ...
Width	mm	150	160	160	150 ... 160	171	160	160	171	160
Height	mm	108	127	125	106 ... 140	127	125 ... 127	125	127	125
Length without connector	mm	295 ... 303	330 ... 342	242	213 ... 319	380	262 ... 314	319	380	300
Mass	kg	14.5	25.0	16.0	16.0 ... 20.0	23.0	19.0 ... 19.6	23.0	26.0	23.0

System components

Gun Data Modules

GDM, MGDM



Specific welding gun data such as the electronic nameplate and/or wear counter readings are stored on the gun data modules. The electronic nameplate is used, for example, in the tool workshop for the identification of the welding gun. If several Rexroth welding control systems are used successively, the current wear state of the guns and electrodes must be known to the controls. The Gun Data Module is used for this purpose.

The Measuring Gun Data Module MGDM records the physical values measured on the welding gun, incl. preparation and pre-processing.

Both Gun Data Modules use the Weld Interface Controller Bus (WIC = Sercos) to communicate with the welding control system.

GDM (Gun Data Module)

The GDM (Gun Data Module) has a WIC port that can be used to access the welding control system or a service PC to its accessible memory area.

- ▶ Via the browser, the service PC can call up the electronic nameplate of the gun:
 - Serial number
 - Information on the gun configuration
 - Information on the welding transformer
- ▶ The welding control system can read/write counter readings:
 - Electrode tip wear
 - Gun wear
 - Dressing Cycles
- ▶ Degree of protection IP65

MGDM (Measuring Gun Data Module)

The Measuring Gun Data Module MGDM also has connectors for the following welding gun signals:

- ▶ 24 digital inputs/outputs 24 V DC, configurable as input or output
- ▶ Gun coding
- ▶ Actual value of a force sensor
- ▶ Actual value and calibration of an additional force sensor
- ▶ Actual value for secondary voltage
- ▶ Setpoint and actual value of proportional valve
- ▶ Secondary current and temperature contact of two welding transformers
- ▶ Degree of protection IP65

Additional system components from Rexroth extend the functional possibilities of welding control.

System components		
S20 fieldbus coupler and I/O modules	Allow for the connection of control and display elements and other digital and analog signals	Chapter 3 "I/O systems"
IndraDrive servo drives	Control electric servo motors for the welding gun and/or electrode cutter	Chapter 4 "Servo drives"
Safety zone module	Monitors safety equipment and, if necessary, ensures safe movement of the welding gun	www.boschrexroth.com/welding

SERVICES

7	Best-in-class support and service	406
	Global service offering	408
	Breakdown services	410
	Digital Service Assistant	412
	Remanufacturing and machine optimization	414
	▶ Remanufacturing – increasing availability on a long-term basis	416
	▶ Retrofitting and modernization – long-term investment security for your machines	417
	Shaping the future	418

Best-in-class support and service

Are you looking for a professional service partnership for your automation technology? Then Rexroth is the company you're looking for! We provide you with worldwide support for maintenance work and optimization throughout the entire lifecycle of your machines.

YOUR RELIABLE SERVICE PARTNER

Bosch Rexroth stands for the professional service of a full-service provider worldwide. We offer a comprehensive portfolio of services, from repairs and original spare parts through preventative remanufacturing and retrofitting to machine optimization.

For you this means: maximization of the availability of machines and systems by consulting and service from a single source.
Specifically: less effort and lower costs.

SERVICE LIFECYCLE

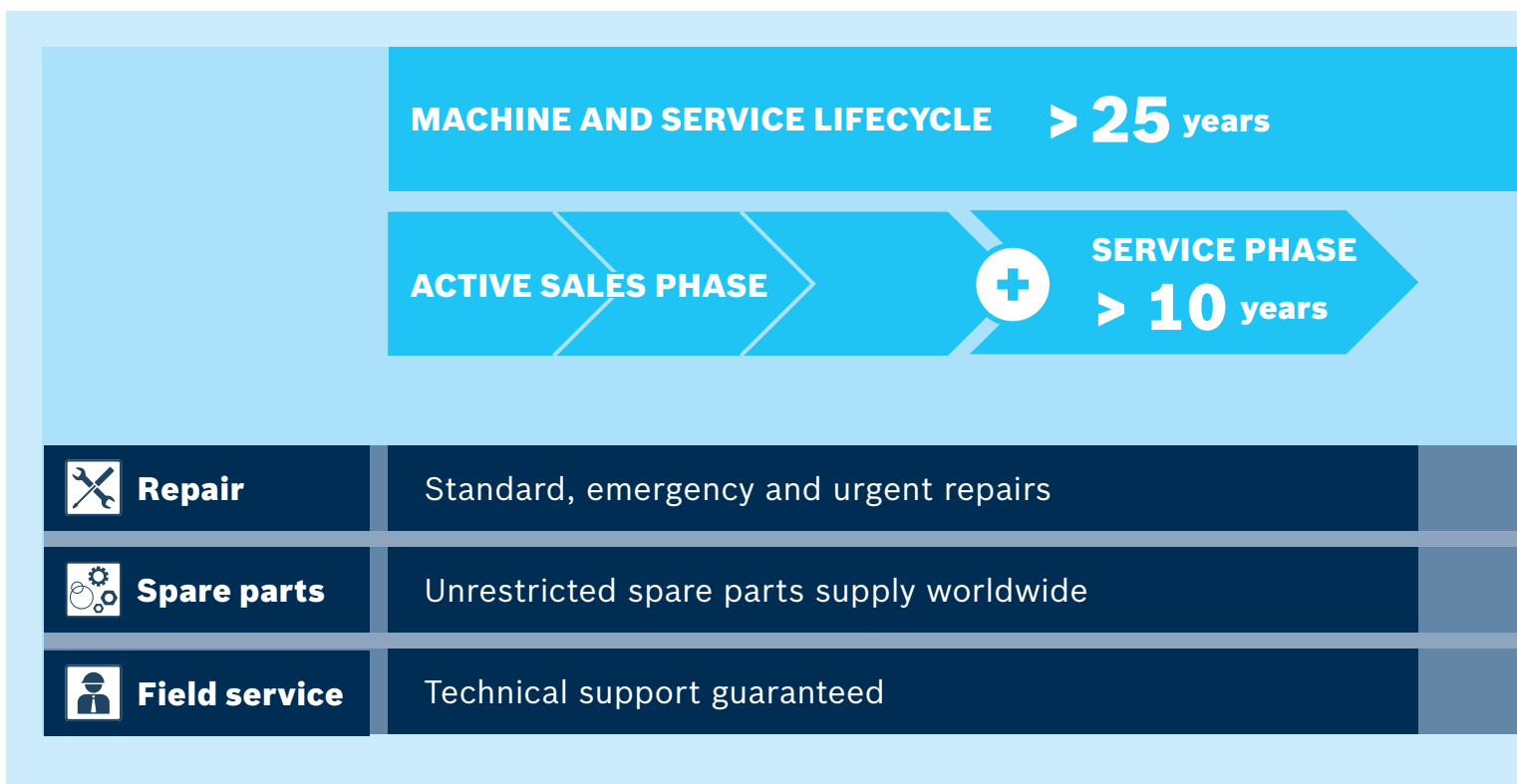

GUARANTEED SERVICEABILITY

The long-term usability of machines and systems is becoming more and more important in economic aspects. This is why we offer exceptional service over the entire life of the machines in the area of automation technology. This way, we safeguard your production.

We guarantee the availability of spare parts, repairs and technical support in the standard not only for all products of the current portfolio, but also for a period of at least 10 years beyond the active sales phase. We then support you in an extended service phase with our services – in many cases we can support machine operation times over 25 years and guarantee them with service agreements.



EXTENDED SERVICE PHASE

5 to 15 years



Product Overhaul +



Long Life Service Contract (LLS)



Retrofitting

- ▶ For contract customers, repair or spare parts supply and technical support are ensured, alternatively retrofitting
- ▶ If not, repair and/or spare parts supply and technical support according to availability

Global service offering

Thanks to our extensive service network in 80 countries with over 200 locations, we are always close to you worldwide. Because short distances are crucial in the service scenario for a quick help – for you just as well as for us. Our experienced service engineers ensure fast repair and spare parts supply in Bosch Rexroth quality – no matter where you are in the world right now.



200
SERVICE CENTERS

5
CONTINENTS

● Service centers

You can also rely on our experienced service specialists at your locations and customers around the world for our other services.

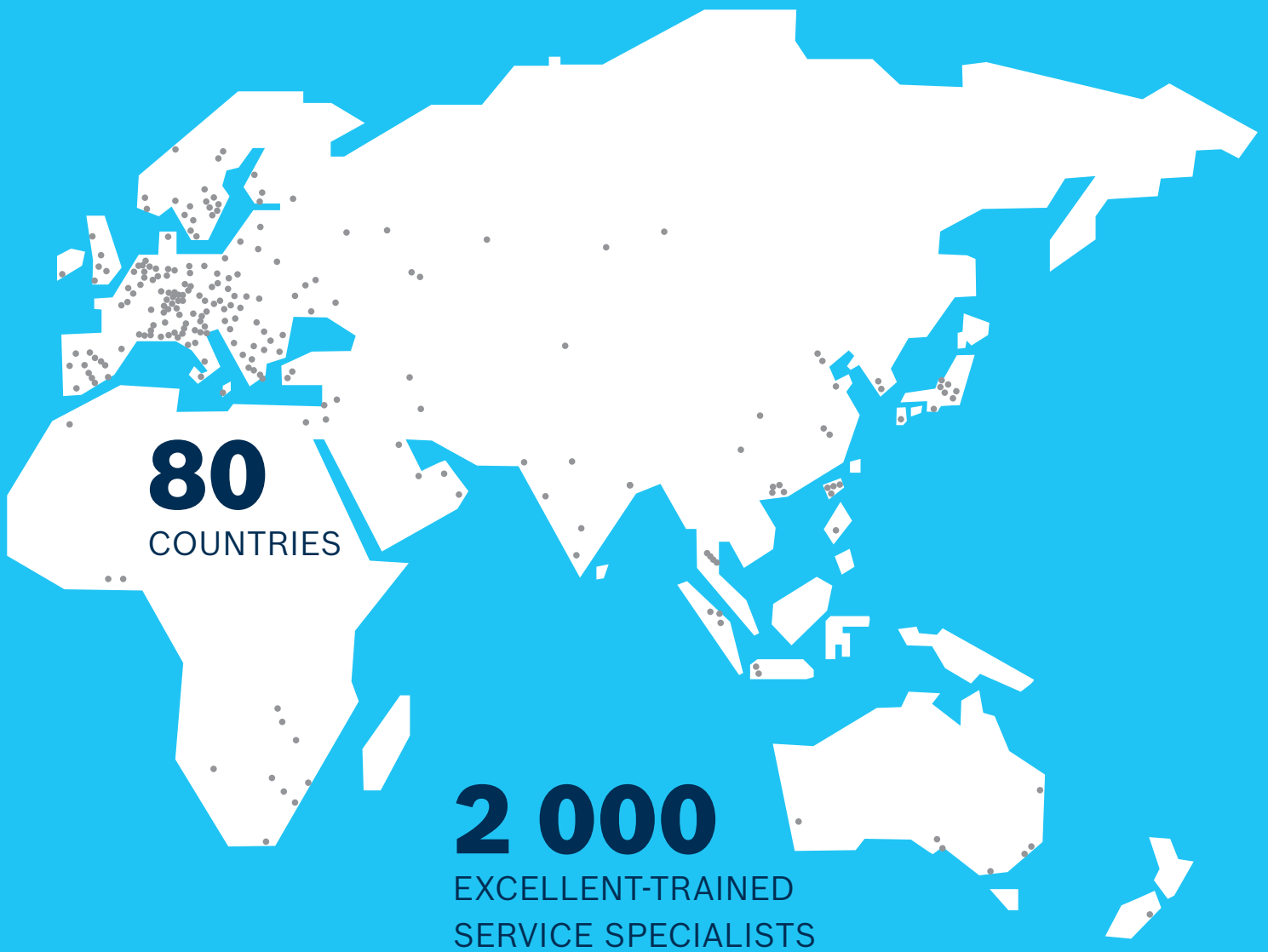

Breakdown services

To get help as quickly as possible, we offer you quick and reliable support worldwide. In this way, we guarantee that your machine or system can be used again after the shortest possible time.

SERVICE HOTLINE: 24/7 PROFESSIONAL SOLUTIONS TO PROBLEMS

When it comes to machine downtimes, every minute counts. We react promptly and make sure that your machine is running again quickly. The Rexroth service is available to be contacted by you 24-hours a day, 365 days a year. Based on many years of experience, the specialists talk through initial measures on the telephone for troubleshooting and for fault resolution. If necessary, our experts will initiate the express delivery of spare parts, arrange emergency repairs or directly send a service specialist to you.

- ▶ Permanently available (24/7)
- ▶ Quick and competent
- ▶ Free of charge

FIELD SERVICE – YOUR BOSCH REXROTH SPECIALISTS ON SITE

Whether during commissioning, in case of application problems or troubleshooting and fault resolution: Our field service specialists advise you on all questions relating to increase in productivity and lifecycle extension around the world and implement the measures directly on site. We take a look at the entire system, including all drive and control technologies. In the event of a malfunction, our experts are quickly on site and ensure that your machine or system is running again soon. As a result, we provide quicker solutions to problems and achieve lasting improvements in availability. This saves you time and money.

- ▶ Minimization of downtimes
- ▶ Application support
- ▶ Local presence with 200 service centers around the world
- ▶ Teleservice

SPARE PARTS SERVICE

In the event of a malfunction of machines and systems, the quick delivery of the right spare parts is what counts for you. Only original spare parts from Bosch Rexroth ensure the expected runtime and reliability of your machines. Identify the suitable spare part simply and securely via our digital service assistant or our help desk and order it directly by means of Quick-Link. We will quickly dispatch

IMMEDIATE ASSISTANCE WHEN SERVICE IS NEEDED

Hotline: +49 9352 405060

E-mail: service@boschrexroth.de

**24/7/365
AVAILABLE**

**ALSO ON
WEEKENDS AND
PUBLIC HOLIDAYS**

the spare part from our regional logistics centers with optimized spare parts stocking. We ensure that the required original spare part is available on site in an emergency within a few hours. On request, our field service will put the machine into operation after completed replacement.

More than 25 years spare parts availability

The long-term usability of machines and systems is becoming more and more important for you under economic aspects. For this reason, we guarantee spare parts availability for more than 25 years. We are also able to supply many original spare parts for the predecessor brands Bosch, Indramat and Nyquist.

eShop

No matter if it's 11 p.m. or 6 a.m.: Our eShop is open for you at any time of the day or night and offers functions that make ordering products even more convenient. Registered customers can view the delivery status of the components they have ordered at any time.

www.boschrexroth.com/eshop

- ▶ Simple and quick identification and ordering of spare parts thanks to our Digital Service Assistant
- ▶ Planning capability through fast and reliable delivery worldwide – in an emergency even on the same day
- ▶ Safety through original spare parts with full performance and corresponding compatibility
- ▶ Higher productivity and availability of machinery thanks to the latest hardware and software versions
- ▶ Service for all old brands (Bosch, Indramat, Nyquist)

REPAIR SERVICE

Defective components do not always have to be repurchased. In the case of high-quality components, it is often sufficient to replace or repair wearing parts or defective components. In modern, certified workshops we check and repair according to manufacturer's

specifications and exclusively with original spare parts on the agreed deadline.

If required, our trained technicians repair the components within one day or completely overhaul the product according to Bosch Rexroth factory standards. The components are put into an as-new condition – even with a warranty of 24 or optionally up to 60 months.

- ▶ Minimization of downtimes through fast and competent assistance – in an emergency even on the same day
- ▶ Increased economic efficiency through the exclusive use of original spare parts
- ▶ Safety through repair execution according to manufacturer specifications
- ▶ Service for all old brands (Bosch, Indramat, Nyquist)
- ▶ Free pick-up service

SERVICE AVAILABILITY MANAGEMENT (SAM)

Is fast material availability with simultaneous cost optimization important to you? We support you on the way to your goal! Bosch Rexroth ensures fast, reliable and global delivery of specified products within defined periods of time. Within the framework of the contract, we agree upon a detailed material list of components and reaction times.

- ▶ Increased machine availability
- ▶ Agreed reaction times
- ▶ Predictable, calculable costs
- ▶ No stock build-up on site – reduced storage costs

Digital Service Assistant – First aid in case of machine downtime

The Digital Service Assistant is available around the clock directly on your smartphone and tablet. You can access all service tools at any time and get an overview of the status of your machines.

- ▶ **Direct connection to the help desk – on request with data transmission to quickly resolve the failure**
- ▶ **Online diagnostics via the control**
- ▶ **Simple product identification via scanner**
- ▶ **Direct spare parts and repair order**
- ▶ **Quick access to documentation**

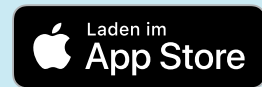
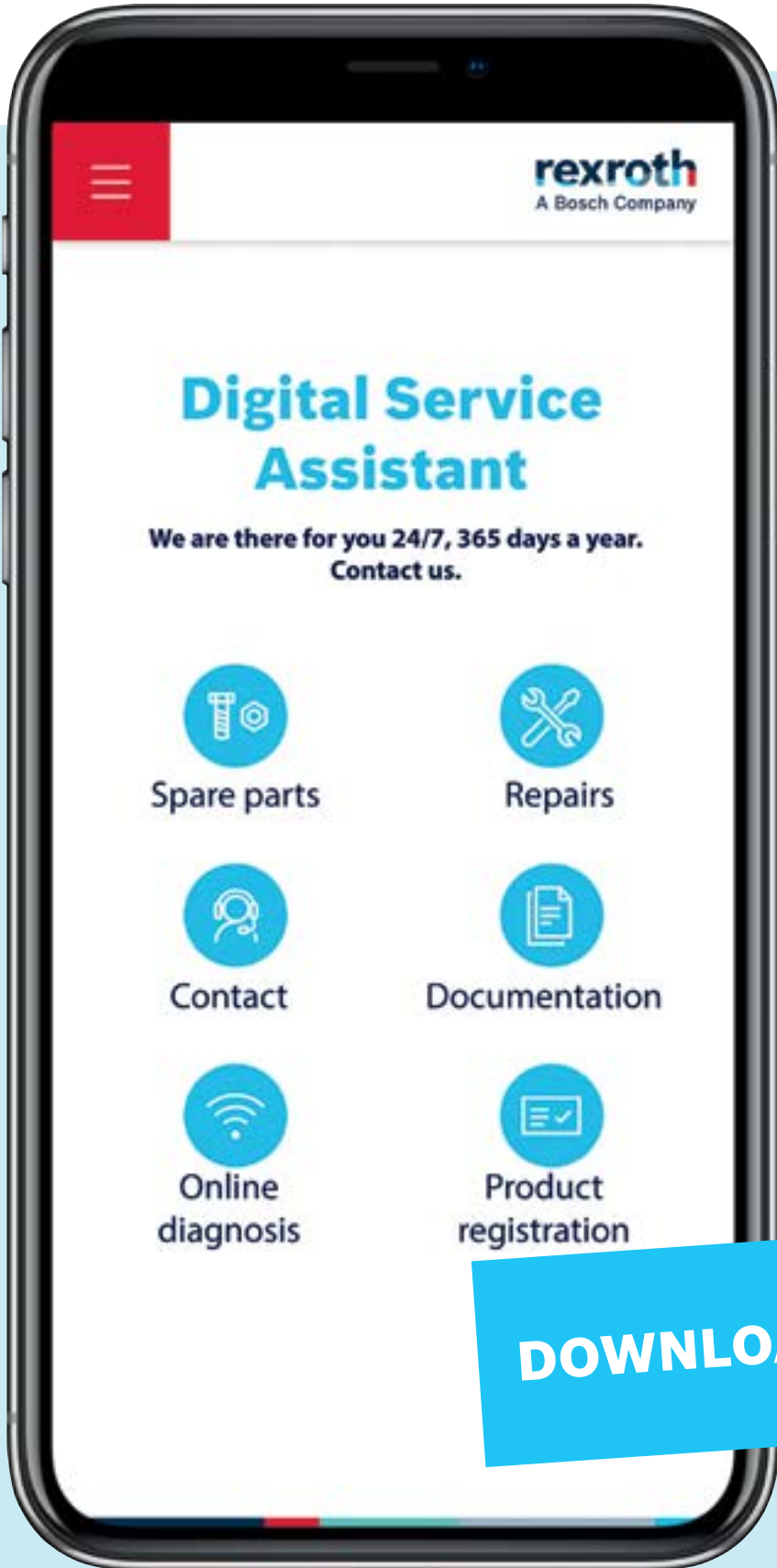



Remanufacturing and machine optimization

Extend the economic service life of your machines and systems with minimal investment and time expenditure. We offer a finely scalable portfolio of services relating to the extended service life of individual components or the modernization of entire systems.

EXTEND SERVICE CAPABILITY, INCREASE PRODUCTIVITY

With various measures, such as remanufacturing, retrofitting and modernization, we ensure that your machines and systems are always state-of-the-art in technology – economically and efficiently. The acquisition of new machinery and systems is linked to high levels of investment and will leverage your valuable capital over the long term. Our service packages are significantly

cheaper than a new investment and result in higher productivity with lower energy consumption. Above all, however, we safeguard production with your existing machines until you need it.

Our experts consult you on the basis of your individual requirements and find the right solution for you. Profit from the advantages of our services that have proven many times in the field.



**MAXIMUM
PRODUCTIVITY
INCREASE UP TO
25 %**

**MAXIMUM
AVAILABILITY
BY PLANNED
PRODUCT
OVERHAUL**

**EXTENDING SERVICE
AVAILABILITY
BY MORE THAN
20 YEARS**

**ULTRA-HIGH
LEVELS OF
SAFETY
DUE TO SAFETY AND
IT SECURITY
STANDARDS**

Remanufacturing – increasing availability on a long-term basis

A preventive remanufacturing ensures the availability and productivity of your machines in the long term. Our experienced technicians thoroughly analyze the need for action on site and carry out the exchange and commissioning of the overhauled components.

With the remanufacturing, maintenance costs are significantly reduced – throughout the entire machine lifecycle. As a result, we offer high availability and low maintenance costs at the same time.

- ▶ Overhaul based on certified Bosch Rexroth factory standards
- ▶ Replacement of all wearing parts
- ▶ Increased cost effectiveness thanks to original spare parts
- ▶ 24-month warranty, can be extended to 60 months
- ▶ Also possible for old brands (Bosch, Indramat, Nyquist)
- ▶ Optional: Commissioning on site
- ▶ Optional: Extending service availability by more than 20 years



Retrofitting and modernization – long-term investment security for your machines

MORE EFFICIENCY FOR YOUR MACHINES AND SYSTEMS

After several years of operation, machines and systems are no longer state-of-the-art in technology. Often they will then consume more energy than necessary, will be outdated in terms of productivity and will be increasingly less reliable. The solution: retrofitting or modernization. This way, you can increase the profitability and energy efficiency of machines and systems and extend the lifecycle.

We offer scalable retrofitting services from refit of components and modernization of entire machines and systems – including software adaptation – to an upgrade to Industry 4.0.

We will be happy to advise you and assess the optimization potential of your machines and systems together.



Investment protection – service availability of existing machines extended by up to 20 years



Productive – cycle times reduced by up to 25 %



Easy – exchange/overhaul of hardware and software components including engineering, commissioning, and workshop acceptance on site



Time-saving – minimal downtime thanks to pre-engineering



Safe – compliance with current directives regarding machine and IT security



i4.0 ready – real-time access to data thanks to networking of machines and systems



RECONFIGURATION OF PRODUCT LINE

Shaping the future

 NETWORK

 ENGINEERING

 CONDITION

UPGRADING TO INDUSTRY 4.0

As a complete provider and technology leader, Bosch Rexroth makes your company fit for Industry 4.0 challenges quickly and cost-effectively. Our solutions make it easy to achieve a better level of transparency for your production. This creates the conditions for productivity increases and you are optimally prepared for the implementation of individual predictive maintenance solutions. Your investments pay for themselves within a short time.

COMPLETE IOT PACKAGE WITH HARDWARE AND SOFTWARE

- ▶ Quick and easy access to your production data
- ▶ Connecting sensor systems (plug and run)
- ▶ Simple configuration and commissioning
- ▶ Local data monitoring



IT SECURITY

One of the basic requirements for Industry 4.0 is essential for the successful implementation of the factory of the future, the security of information and communication technologies. Create the basis for your digital, networked production by safeguarding data on your machines and manufacturing processes according to our high IT security standards. Our experts analyze your system by means

of a threat and risk analysis and define individually tailored measures to secure your machines and systems. The implementation of the developed security concepts forms the basis for the effective minimization of the risks identified. Further services that guarantee a hardening of your IT security include the validation of applied security mechanisms as well as the performance of vulnerability analyzes.

TRAINING

8

Training – Drive & Control Academy

423



Training – Drive & Control Academy

The skills and competence of your employees, within the internal market, provide a decisive advantage in the global competition. Under the Drive & Control Academy, Rexroth offers a practically oriented portfolio of knowledge products in the area of drive and control technology. The Academy sets standards in the didactical processing of specialized and integrated know-how. And that applies equally to customers, employees and training and further development centers.

The offers are always compiled according to the same principles:

- ▶ Practical understanding of the latest technology
- ▶ Target group specific training courses
- ▶ Latest forms of teaching and media

The Drive & Control Academy concept is based on the four pillars of our knowledge transfer:

- ▶ Training
- ▶ Training systems
- ▶ Media
- ▶ Knowledge portal

KNOWLEDGE IS EVERYTHING

As a leading specialist in drive and control technology, Bosch Rexroth has unique technology know-how. We will be glad to share this knowledge. For trainees and students as well as to professionals and employees.

With Drive & Control Academy, we support the customized training and further development as well as the qualification of technical experts. Practical, target group specific and with state-of-the-art methods.

THE THEME FIELDS

- ▶ Electric controls and drives
- ▶ Welding technology
- ▶ Industry 4.0
- ▶ Safety technology
- ▶ Energy efficiency
- ▶ Industrial hydraulics
- ▶ Mobile hydraulics / mobile electronics
- ▶ Linear motion and assembly technology
- ▶ Tightening technology
- ▶ Pneumatics
- ▶ Automation/mechatronics
- ▶ Applications



**PRACTICALLY
ORIENTED
TRAINING
MADE TO MEASURE**

TRAINING

With Rexroth, knowledge transfer is always based on state-of-the-art technology as well as modern methods and media. Whether classroom training, e-learning or e-training with online access via the Rexroth learning world, whether special field training or also blended learning, which ideally combines the advantages of face-to-face and e-learning modules – regardless of the training method: the principle of customer proximity is in the foreground.

In addition to the Rexroth standard training courses from our training program, which we can also implement directly in your company, we also offer you individual training courses for the qualification of your employees. We will be glad to create a complete qualification concept tailored to your applications and company-specific requirements.

MEDIA

The goal of Rexroth is to offer teaching and learning media that are technologically up-to-date and have a high practical reference. Therefore, they contain state-of-the-art e-learning and e-training modules with numerous animations and simulation-supported learning units. Also printed specialist books and manuals, e-books, apps, software and useful tools.

The Drive & Control Academy media range media portfolio comprises:

- ▶ Literature in printed and electronic form
- ▶ e-learning and e-training sessions
- ▶ Videos
- ▶ Work material
- ▶ Posters and sectional models
- ▶ 2D and 3D animations and apps
- ▶ Software
- ▶ Online knowledge subscriptions

TRAINING SYSTEMS

The modular training systems developed by the Rexroth specialists provide beginners and advanced users with hands-on technical know-how and solution competence. In-depth practically oriented knowledge is made available by means of industrial serial components – with internationally standardized programming languages and open interfaces. The practically oriented knowledge is passed on to this hardware with specially developed exercises. They are tailored to the qualification levels of industry and educational institutions.

Target group specific training courses

- ▶ Basic training courses
- ▶ Practically oriented product training courses
- ▶ Customized training courses

KNOWLEDGE PORTAL

Knowledge on the Internet – Rexroth is working on it with the development of the knowledge portal: Around the topics of the existing Rexroth learning world, the portal will evolve into a multimedia access point for knowledge from the areas of control, drive and motion control. The aim is to become a central component in professional and academic training in the future. This gives users unique access to high-quality information. Community and wiki functions allow structured transfer of knowledge and experience for the first time.





Drive & Control Academy

 **Bahnhofplatz 2
97070 Würzburg
Germany**

 **+49 9352 18-1920**

 **training@boschrexroth.de**

 **www.boschrexroth.com/training**

ANNEX

Additional information

Bosch and Bosch Rexroth

Bosch

Information on “Technology for life” and how Bosch products impress people who improve the quality of life and contribute to the protection of natural resources can be found here:

■ www.bosch.com

Bosch Rexroth

Information on Bosch Rexroth AG can be found at:

■ www.boschrexroth.com

7:51 Blog

Blog entries for factory automation, industrial hydraulics and mobile applications can be found at:

■ www.751.rexroth

Automation & Electrification Solutions

Bosch Rexroth Automation & Electrification Solutions

Product information, CAD and EPLAN data on electrical automation solutions can be found at:

■ www.boschrexroth.com/automation

Bosch Rexroth Process Controls

Product information and CAD data for resistance welding systems can be found at:

■ www.boschrexroth.com/welding

Information

Documentation

Current product and system documentation regarding electrical automation solutions and resistance welding components can be found at:

■ www.boschrexroth.com/mediadirectory

CAD data

You can find the latest CAD data on electrical automation solutions and resistance welding components at:

■ www.boschrexroth.com/automation-cad

Configurators and tools

Engineering tools and design software for electrical automation solutions can be found at:

■ www.boschrexroth.com/configurators

Services

eShop

The Bosch Rexroth eShop can be found at:

■ www.boschrexroth.com/eshop

Contact Locator

The global contacts of Bosch Rexroth are available at:

■ www.boschrexroth.com/contact

Training

Information on training offered by Bosch Rexroth can be found at:

■ www.boschrexroth.com/training

Service

Information on services from Bosch Rexroth can be found at:

■ www.boschrexroth.com/service

Digital Service Assistant

Information on the Bosch Rexroth service app can be found at:

■ www.boschrexroth.com/dsa

To install the digital service assistant on your smart device, scan the QR code. You are automatically forwarded to the corresponding page in the Google Play Store and/or Apple App Store.



Social Media

f **Facebook**
Bosch Rexroth International
 ■ www.facebook.com/BoschRexroth

in **LinkedIn**
Bosch Rexroth International
 ■ www.linkedin.com/company/bosch-rexroth

Twitter
Bosch Rexroth International
 ■ www.twitter.com/BoschRexroth

Instagram
Bosch Rexroth International
 ■ www.instagram.com/boschrexroth_global

YouTube
Bosch Rexroth International
 ■ www.youtube.com/user/BoschRexrothGlobal

Other Bosch Rexroth technologies for factory automation

Tightening technology

In Industry 4.0, people play the main role – and our intelligent and responsive tightening technology products, such as the Nexo cordless electric nut runner, give you powerful tools to maximize your production productivity.

■ www.boschrexroth.com/tightening

Assembly technology

The future-capable production is both highly networked and fully flexible – and our assembly and material handling technology is designed in such a way that it provides exactly this flexibility and productivity.

■ www.boschrexroth.com/assembly-technology

Linear motion technology

Our linear motion technology ensures that high loads can be moved precisely and extremely dynamically. The right solution is found in just a few clicks and is shipped within the delivery time required for the market.

■ www.boschrexroth.com/linear-motion-technology

Industrial hydraulics

Our portfolio of connectable hydraulics from components to complete system solutions helps you to create energy-efficient, flexible, and intelligent solutions for series machines and machine equipment for your country and in offshore applications.

■ www.boschrexroth.com/industrial-hydraulics

Index

- ▶ **Symbols**
 - 1MB 364
 - 24/7 professional solutions to problems 410
- ▶ **A**
 - About Bosch Rexroth 2
 - ADVANCED single-axis control unit
 - CSH02 270
 - Analog input modules
 - S20-AI-x 124
 - S20-SGI-2 126
 - Analog input/output module
 - S20-AIAO-2 130
 - Analog output modules
 - S20-AO-x 128
 - Annex 426
 - App 412
 - Asynchronous high-speed motor
 - 1MB 364
 - Asynchronous servo motors
 - MAD 312
 - MAF 318
 - Automation 5
 - Automation software 13, 16
 - FTS 50
 - ILC 54
 - IoT Gateway 60
 - IoT Insights 64
 - MLC 32
 - MLN 42
 - MPC 48
 - MTX 20
- ▶ **B**
 - BASIC double-axis control unit
 - CDB02 268
 - BASIC single-axis control unit
 - CSB02 266
 - Boost module
 - S20-PWR 152
 - Bosch Rexroth 5
 - Box PC
 - PR21 74
 - PR31, PR4 76
 - VPB40.4 78
 - Breakdown services 410
 - Bus coupler
 - S20-x-BK 122
 - SLC-x-Gxxx 178
- ▶ **C**
 - Cabinet-based drive technology
 - ADVANCED single-axis control unit 270
 - BASIC double-axis control unit 268
 - BASIC single-axis control unit 266
 - Compact converters 232
 - Double-axis inverter 250
 - Multi-axis converters 240
 - Single-axis converters 232, 236, 238
 - Single axis inverter 246, 254
 - Supply unit 242, 252
 - Universal inverters 256
 - Cabinet-free drive technology
 - Capacity module 228
 - Control electronics 222
 - Mains module 226
 - Motor-integrated servo drive 216
 - Near motor servo drive 218, 220
 - Supply module 224
 - Capacity module
 - KLC03 228
 - CDB02 268
 - CNC 13, 20
 - Commissioning 374, 410
 - Communication modules
 - S20-DALI-2-PWR, S20-RS-UNI, S20-KNX-1 142
 - S67E-x-IOL8-DI4-M12-6P 160
 - Compact converters
 - HCS01 232
 - Compact operator panels
 - VR21 84
 - Comprehensive production expertise 5
 - Control 94, 96, 106, 172
 - Control components 66
 - Control electronics
 - KCU02 222
 - Control system 94, 164
 - Control units 264
 - Converters
 - Compact converters 232
 - Multi-axis converters 240
 - Single-axis converters 232, 238
 - Courses and trainings
 - Theme fields 423
 - CPU modules 176
 - CSB02 266
 - CSH02 270
- ▶ **D**
 - Digital input modules
 - S20-DI-x 132
 - Digital input/output modules
 - S20-DI-16/4-DO-8/3-HS, S20-DIDO-8/1 136
 - SLC-3-xTxx 180
 - Digital output modules
 - S20-DO-x 134
 - Digital Service Assistant 412
 - Dimensioning 388
 - Display
 - DR 80
 - VDP81, VDP82 82
 - VR21 84
 - Double-axis inverter
 - HMD01 250
 - DR 80
 - Drive 15, 192
 - Drive components 192
 - Drives 15, 192
 - Drive software
 - MPx/PSB 272
- ▶ **E**
 - EFC3610 198
 - EFC5610 202
 - Embedded controls
 - XM 96
 - XM controls 98, 100
 - XM extension modules 102, 104
 - YM 106
 - YM control modules 110
 - YM drive modules 112
 - YM housing 108
 - Engineering software
 - IndraSize 388
 - IndraWorks Engineering 374
 - IndraWorks SafetyManager 386
 - IndraWorks WebComposer 387
 - IndraWorks WinStudio 384
- ▶ **F**
 - Fieldbus coupler
 - S20-x-BK 122
 - SLC-x-Gxxx 178
 - Frequency converters
 - EFC3610 198
 - EFC5610 202
 - FTS 50
 - Function module
 - SLC-3-MOC000300 184
- ▶ **G**
 - Gateway 60
 - Gateway modules 178
 - Gearboxes 324
 - GDM 402
 - Gun Data Modules 402
 - Global service offering 408
 - GTE 324
 - GTM 330
 - Guaranteed serviceability 407
- ▶ **H**
 - HCS01 232
 - HCS02 236
 - HCS03 238
 - HCT02/HCQ02 240
 - HMD01 250
 - HMS01 246
 - HMS02 254
 - HMU05 256
 - HMV01 242
 - HMV02 252
 - Hotline 410
- ▶ **I**
 - ILC 54
 - Incremental value encoder modules
 - S20-CNT-INC-2/2, S20-INC-2 144
 - IndraControl 10
 - IndraDrive 11, 206
 - Cabinet-based drive technology 230
 - Combination options 208
 - Cabinet-free drive technology 210
 - Safety technology 280

– Software	272				
IndraDrive Cs					
– HCS01	232				
IndraDrive Mi	210				
IndraDrive software	272				
IndraSize	388				
IndraWorks	10				
IndraWorks Engineering	374				
IndraWorks SafetyManager	386				
IndraWorks WebComposer	387				
IndraWorks WinStudio	384				
Industrial PC	74, 76, 78, 86				
Industrial PC and HMI	70				
– Box PC	74				
– Compact operator panels	84				
– Display	82				
– Machine operator panels	90				
– Multi-touch display	80				
– Panel PC	86				
Industry 4.0	60, 64, 188, 190, 418				
Input	116, 180, 264				
Inverter					
– Double-axis inverter	250				
– Inverter near the motor	218, 220				
– Motor-integrated inverter	216				
– Single axis inverter	246, 254				
– Universal inverters	256				
I/O	116, 180, 264				
I/O systems	116				
– S20	118				
– S67E	158				
IoT	60, 64, 188, 190				
IoT Gateway	60				
IoT hardware	186				
– IoT Rack	188				
– IoT sensors	190				
IoT Insights	64				
IoT package	418				
IPC	74, 76, 78, 86				
IT security	419				
► K					
KCU02	222				
Kit motors	336				
– Asynchronous high-speed motor	364				
– Synchronous high-speed motor	358				
– Synchronous linear motors	338, 342, 346				
– Synchronous torque motor	352				
KLC03	228				
KMS02	218				
KMS03	220				
KMV03	224				
KNK03	226				
Knowledge portal	424				
KSM02	216				
► L					
Lifecycle management	406				
Flexible transport system	50				
► M					
Machine operator panel	80, 82, 84, 86, 90, 92				
– VAM15, VAM21	90				
– VAM81, VAM82	92				
Machine optimization	414				
MAD	312				
MAF	318				
Mains module					
– KNK03	226				
MBS	358				
MBT	352				
MCL	338				
Media	424, 428				
MGDM	402				
MKE	306				
ML3	342				
MLC	32				
MLD	42				
MLF	346				
Modernization	417				
Motion control	13, 32, 42, 48				
Motion control systems					
– MLC	32				
– MLD	42				
– MPC	48				
Motor	286				
Motor-integrated servo drive					
– KSM02	216				
Motors and transmissions	286				
– Kit motors	336				
– Servo motors and planetary gearboxes	288				
MPC	48				
MS2E	302				
MS2N	290				
MSM	310				
MTX	20				
– CNC system based on embedded control system	20				
– Operation Desktop	28				
– Virtual Machine Builder	31				
– Virtual Machine Simulation	30				
Multi-axis converters					
– HCT02/HCQ02	240				
Multi-touch display					
– DR	80				
► N					
Near motor servo drives					
– KMS02	218				
– KMS03	220				
NYM04.1-MCU	110				
NYM04.1-xxx	112				
NYS04.x-ST	108				
► O					
Operating software					
– PRI	399				
Operation Desktop	28				
Operator panels					
– Compact operator panels	84				
– Display	82				
– Multi-touch display	80				
– Panel PC	86				
Output	116, 180, 264				
► P					
Panel PC	86				
Planetary gearboxes					
– GTE	324				
– GTM	330				
PLC	14, 54				
PLC & IoT	14				
Portfolio					
– Control components	68				
– Drive components	194				
Power measurement modules					
– S20-PM-EF	150				
PR21	74				
PR31, PR4	76				
PRC	398				
PRI	399				
Process Control	15				
Process control systems	15, 392				
Production expertise	5				
Product portfolio	5				
Programming	170, 174, 370, 399				
PSG	400				
Pulse-width modulation modules					
– S20-PWM-2/2, S20-PWM-4T	148				
► R					
Rack	188				
Relay modules					
– S20-DOR-4/2-220-AC	138				
– SLC-A-UExxx	182				
Remanufacturing	414, 416				
Repair service	411				
Resistance welding	392				
Retrofitting	417				
Retrofitting and modernization	417				
► S					
S20	118				
– Analog input module	126				
– Analog input modules	124				
– Analog input/output module	130				
– Analog output modules	128				
– Boost module	152				
– Communication modules	142				
– Digital input modules	132				
– Digital input/output modules	136				
– Digital output modules	134				
– Fieldbus coupler	122				
– General technical specifications and dimensions	120				
– Relay module	138				
– Safety related digital input modules	154				
– Safety related digital output modules	156				
– Technology modules	144–150				

Index

– Temperature modules	140	Servo gearboxes	286, 324	– S20-PWM-2/2, S20-PWM-4T	148
S20-AIAO-2	130	Servo motors	286, 288	– S20-SSI-AO-1/1, S20-AI6-AO2-SSI2	146
S20-AI-x	124	Servo motors and planetary gearboxes	288	Temperature modules	
S20-AI-x-xTx	140	Servo planetary gearboxes		– S20-AI-x-xTx	140
S20-AO-x	128	– GTE	324	Training	420
S20-CNT-INC-2/2, S20-INC-2	144	– GTM	330	Training systems	424
S20-DALI-2-PWR, S20-RS-UNI, S20-KNX-1	142	Single-axis converters		Transformer	400
S20-DI-16/4-DO-8/3-HS, S20-DIDO-8/1	136	– HCS01	232	Transport system	50
S20-DI-x	132	– HCS02	236		
S20-DOR-4/2-220-AC	138	– HCS03	238		
S20-DO-x	134	Single-axis inverter		► U	
S20-PM-EF	150	– HMS01	246	Universal inverters	
S20-PWM-2/2, S20-PWM-4T	148	– HMS02	254	– HMU05	256
S20-PWR	152	Sizing	388	► V	
S20-SGI-2	126	SLC-3-CPUx	176	VAM15, VAM21	90
S20-SSDI-8/4, S20-PSDI-8/4	154	SLC-3-MOC000300	184	VAM81, VAM82	92
S20-SSDO-8/3, S20-PSDO-8/3	156	SLC-3-xTx	180	VDP81, VDP82	82
S20-SSI-AO-1/1, S20-AI6-AO2-SSI2	146	SLC-A-UExxx	182	Virtual Machine	
S20-x-BK	122	SLC-x-Gxxx	178	– Builder	31
S67E	158	Software	16, 272, 370	– Simulation	30
– Communication modules	160	– IndraWorks Engineering	374	VPB40.4	78
S67E-x-IOL8-DI4-M12-6P	160	– IndraWorks SafetyManager	386	VR21	84
SafeLogic	166	– IndraWorks WebComposer	387	VR31, VR4	86
– Safety components	171	– IndraWorks WinStudio	384		
– Safety functions	168	– MTX Operation Desktop	28	► W	
– Software	170	– MTX Virtual Machine Builder	31	WebComposer	387
SafeLogic compact	172	– MTX Virtual Machine Simulation	30	Welding control system	392
– CPU modules	176	– Operating Software PRI	399	– PRC	396
– Digital I/O modules	180	– SafeLogic Designer	174	Welding transformers	
– Function module	184	– SafetyManager	170	– PSG	400
– Gateway modules	178	Solutions portfolio	10	WinStudio	384
– Relay modules	182	Spare parts service	410		
– Software tool	174	SSI interface modules		► X	
SafeLogic Designer	174	– S20-SSI-AO-1/1, S20-AI6-AO2-SSI2	146	XM	96
Safety	164, 280	Supply module		XM controls	
Safety components	171	– KMV03	224	– XM21, XM22	98
Safety controls	164	Supply units		– XM42	100
– SafeLogic	166	– HMV01	242	XM extension modules	
– SafeLogic compact	172	– HMV02	252	– XFE01.1-FB	102
Safety-CPU	104	Synchronous high-speed motor		– XFE01.1-SY	104
Safety functions	168	– MBS	358	► Y	
SafetyManager	170	Synchronous linear motors		YM	106
Safety modules		– MCL	338	YM control modules	
– S20-SSDI-8/4, S20-PSDI-8/4	154	– ML3	342	– NYM04.1-MCU	110
– S20-SSDO-8/3, S20-PSDO-8/3	156	– MLF	346	YM drive modules	
Safety technology		Synchronous servo motors		– NYM04.1-xxx	112
– IndraDrive	280	– MKE	306	YM housing	
Safety related digital input modules		– MS2E	302	– NYS04.x-ST	108
– S20-SSDI-8/4, S20-PSDI-8/4	154	– MS2N	290		
Safety related digital output modules		– MSM	310		
– S20-SSDO-8/3, S20-PSDO-8/3	156	Synchronous torque motor			
Sensor	190	– MBT	352		
Service	404	System components			
– App	412	– GDM, MGDM	402		
– Assistant	412	► T			
– Hotline	410	Tailor-made			
– Lifecycle	406	Automation solutions	13		
– Partner	406	Technology modules			
Servo drives	206	– S20-CNT-INC-2/2, S20-INC-2	144		
		– S20-PM-EF	150		

Proof of image

Bosch, GF Machining Solutions Management SA, fotolia@A+, fotolia@crtreasures
fotolia@saicle, freepik@Fanjianhua, freepik@Ydlabs, iStock.com@me4o
shutterstock@best_vector, shutterstock@Sergey Nivens

App Store® is a trademark of Apple Inc., registered in the U.S. and other countries.
Google Play and the Google Play logo are trademarks of Google LLC.

The data specified above only serve to describe the product. No statements concerning a certain condition or suitability for a certain application can be derived from our information.

The information given does not release the user from the obligation of own judgment and verification. It must be remembered that our products are subject to a natural process of wear and aging.

Bosch Rexroth AG

Bgm.-Dr.-Nebel-Str. 2
97816 Lohr, Germany
www.boschrexroth.com/automation

**Your local contact can be
found at:**

www.boschrexroth.com/contact

