

**Orientalmotor**

Stepper Motor and Driver Package *αSTEP*

# AZ Series

Equipped with Battery-Free Absolute Sensor



**A**DVANCED  
PERFORMANCE

# Absolute × Battery-Free Brings advanced POSITIONING close to hand.

The new **AZ** Series line-up achieves absolute positioning without the need for a battery.

As a battery is not needed this contributes to a reduction in total cost.

So the **AZ** Series offers absolute positioning for an affordable price.

\*See page 12 for details on the lineup.



HPG Geared Type



PS Geared Type



□20 mm



□28 mm



□42 mm

Stepper Motor and Driver Package  $\alpha$ STEP

# AZ Series

Equipped with Battery-Free Absolute Sensor

■ Lineup

Standard Options

□20 mm/□28 mm/□85 mm

Geared Options with Electromagnetic Brake

□42 mm/□60 mm/□90 mm



TS Geared Type



Harmonic Geared Type



□60 mm



□85 mm

**A**DVANCED  
PERFORMANCE

Equipped with a newly developed ABZO sensor, this is advanced technology at an affordable price.

## Newly developed **ABZO** sensor

We have developed a compact, low cost, battery-free mechanical absolute sensor (patented). This affordable motor series allows for productivity improvements and cost reductions.



### ● Mechanical Sensor

Analog clocks measure the current time based on the positions of the second hand, minute hand and hour hand. ABZO sensor is a mechanical sensor equipped with multiple gears equivalent to the hands on a clock. As it detects positioning information by detecting the angles of the respective gears, a battery is not required.

### ● Multirotation Absolute System

Absolute position detection is possible with  $\pm 900$  rotations (1800 rotations)\* of the motor shaft from the home position.

\* The frame sizes 20 and 28 mm are  $\pm 450$  rotations (900 rotations).

### ● Home Position Setting

By pressing the switch on the driver surface home position can be set simply, and the home position can be saved with the ABZO sensor. Furthermore, it is possible to set the home position using the data setting software (**MEXE02**) or the external input signal.

·Basic principles are like an analog clock

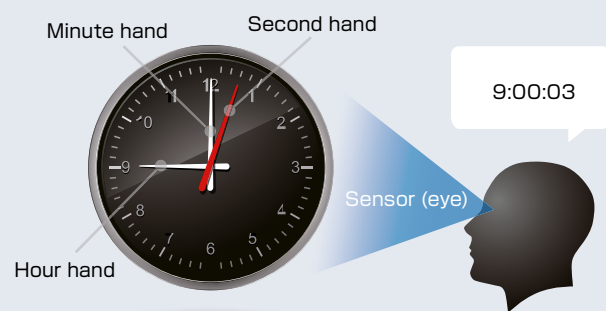

·Home Position Setting



## External Sensors Not Required

As it is an absolute system, external sensors such as the home sensor or limit sensor are not required.

### ● High Speed Return-to-Home + Improved Return-to-Home Accuracy

Because return-to-home is possible without using an external sensor, return-to-home can be performed at high speed without taking the sensor sensitivity into account, allowing for a shortened machine cycle. Furthermore, as return-to-home can be performed without concern for differences in the home sensor, it is possible to improve home position accuracy.

#### Pre-ABZO homing method example

The home position is detected at low speed by detecting the limit sensor ( $\pm$ LS) and home sensor (HOME).

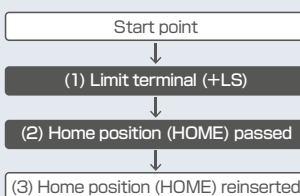
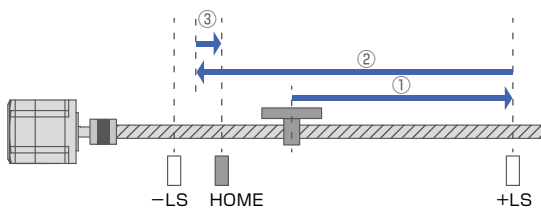

Return-to-home takes time ...



#### AZ Series utilising ABZO sensor homing method

There is no need to detect the limit sensor, and it moves directly at high speed to the home position recorded by the ABZO sensor.

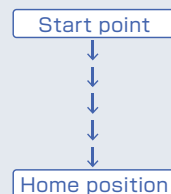
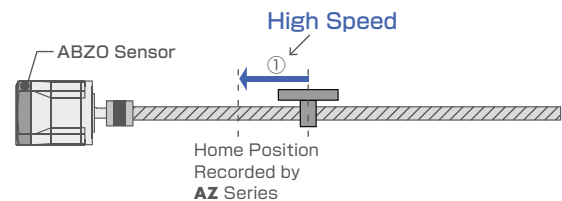

Through high speed return-to-home, machine cycle can be shortened!



### ● Cost reductions

Sensor costs and cable costs can be reduced, leading to lower system costs.

### ● Cable savings

This reduces cabling, increasing device design degree of freedom.

### ● Not affected by sensor

The **AZ** Series eliminates concerns such as sensor malfunctions, sensor faults or disconnection of the sensor lines. For example, sensor malfunctions due to metal flakes or oil mist floating about in the environment will be prevented.

● In systems where limit switches are not possible, software limits can be used to prevent the limit values being exceeded.

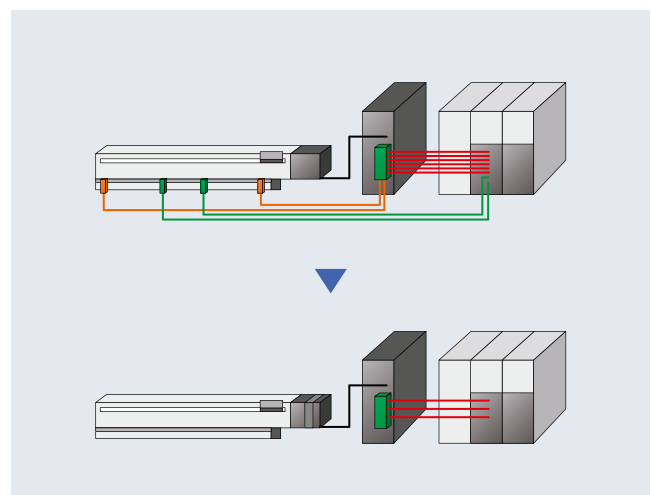

# Achieves a Battery-Free Absolute System.

## Battery-Free ABZO Sensor

As this is a mechanical sensor, a battery is not necessary. The positioning information is managed mechanically by the ABZO sensor.



### ● Maintaining Positioning Information

Even if the power shuts down during a positioning operation, the positioning information is retained. Furthermore, for built-in controller types, positioning operations can restart without performing a return-to-home operation when recovering from an emergency stop of the production line or a power cut.

● If the motor is temporarily replaced it is necessary to reset the home position as the positioning information is stored in the ABZO sensor.

#### Built-in Controller Type

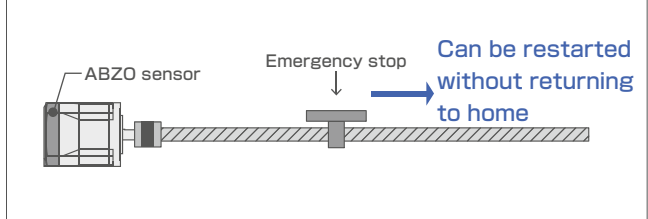

### ● Reduction in Maintenance

There is no need to replace the battery, so the effort and cost of maintenance is reduced.

### ● Drivers take up less Space

As space is not required for the battery, this frees up space within the panel for other purposes.

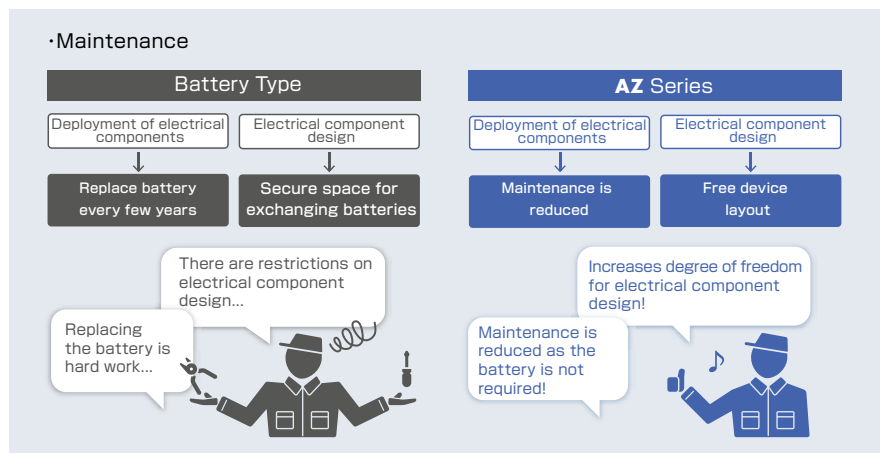

### ● Safe for Overseas Shipping

As normal batteries are self discharging, care is required when transporting the device over long periods, such as in the case of overseas shipments. ABZO sensors do not require batteries, so there is no deadline for the storage of positioning information. Furthermore, there is no need to consider the respective regulations etc. when exporting overseas.

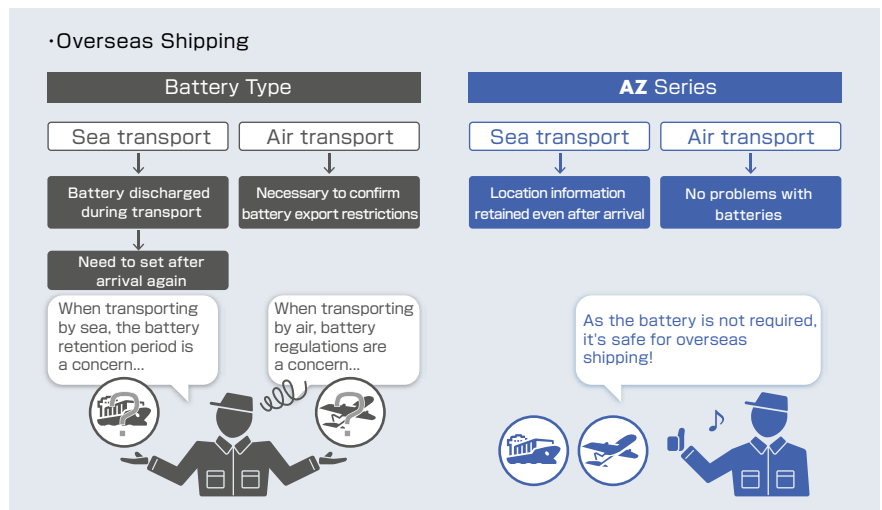

# Save Energy with High Reliability and High Efficiency of $\alpha$ STEP



## High Reliability

We have adopted a proprietary control system.

We have achieved high reliability by linking the benefits of open loop control and closed loop control.

- Keeps driving even in the case of sudden load changes or sudden acceleration

Normally it drives with open loop control in sync with the pulse commands. At times of overload, control instantly switches to control using a closed loop, and perform positioning correction.

- Tuning not required

As normally it drives with open loop control, when there is a change in load, such as in the belt mechanism, cam and chain drive, the positioning can be determined without gain adjustment.

- Outputs an alarm signal in case an abnormality occurs

When overload continuously occurs, an alarm signal is output and when positioning determination is complete, a signal is output. This supports high reliability.

- Storing of stop position

When determining positioning, it stops using the motor's own holding torque without hunting. Therefore it is suitable for use in a situation where vibration could cause a problem when stopping due to a low-rigidity mechanism.

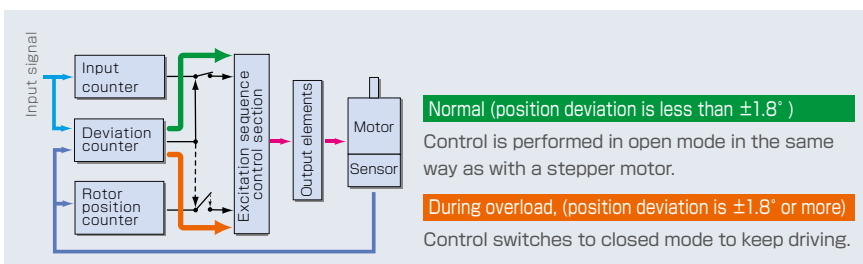

## Energy Saving

Energy saving is also achieved by reducing motor heat generation through high efficiency.

- Reduced heat generation

We have achieved a significant decrease in heat generation through high efficiency.

- The amount of power consumption has been reduced to 47% of its previous levels through energy saving

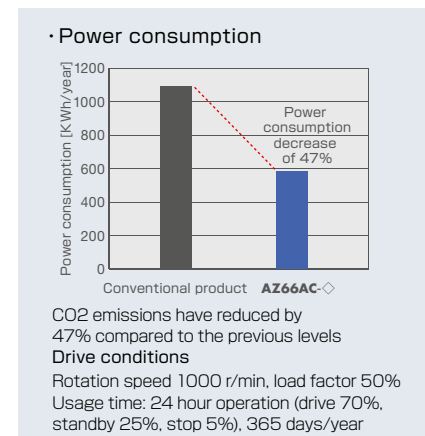
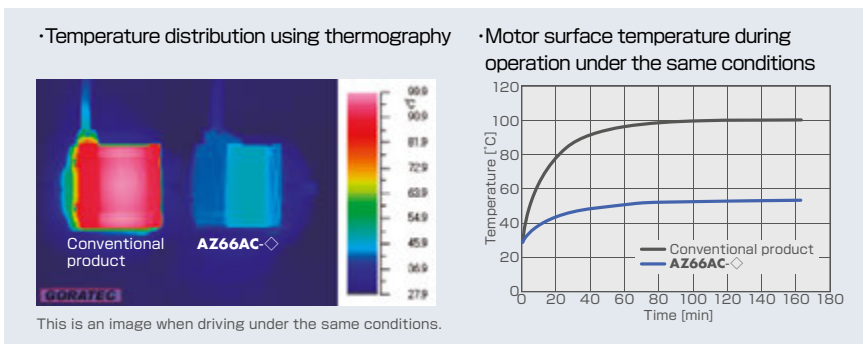

# Two drivers that can be chosen based on the master control system.



## Built-in Controller Type AC DC

The built-in controller type driver allows for up to 256 items of operating data, such as motor speed, position, acceleration / deceleration, interrupts, etc to be executed by a master controller via (1) I/O, (2) Modbus (RTU)/RS-485 or (3) FA network.

### Basic Settings (setting when shipped)

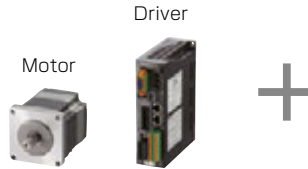

### Operating Data Settings Parameter Changes

Data setting software (**MEXE02**)

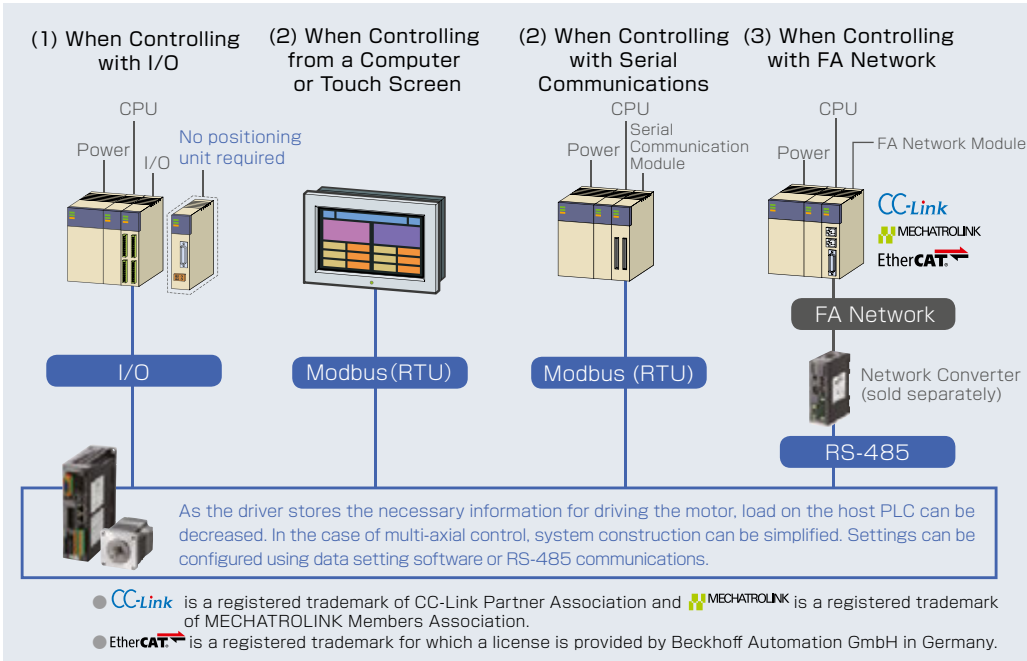
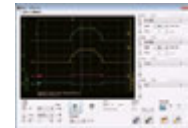

Alternatively this can be set using RS-485 communications. Through the use of network converters (sold separately), CC Link, MECHATROLINK and EtherCAT communications are supported. Through the available communication protocols it is possible to set the operating data, parameters, and operating commands, allowing for shorter design and build times.

## NEW Pulse-Input Type with RS-485 Communication AC DC

This type executes operations by inputting pulses into the driver. It controls the motor using a pulse generator. By using RS-485 communication motor status information (position, speed, torque, alarm, temperature, etc.) can be monitored.

### Basic Settings (setting when shipped)

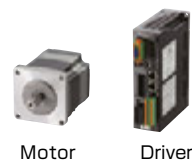

### Operating Data Settings Parameter Settings Data setting software **MEXE02**

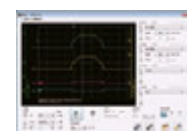

By using the MEXE02 data setting software, the alarm history can be displayed and a variety of monitoring can be customized according to the customer's needs.

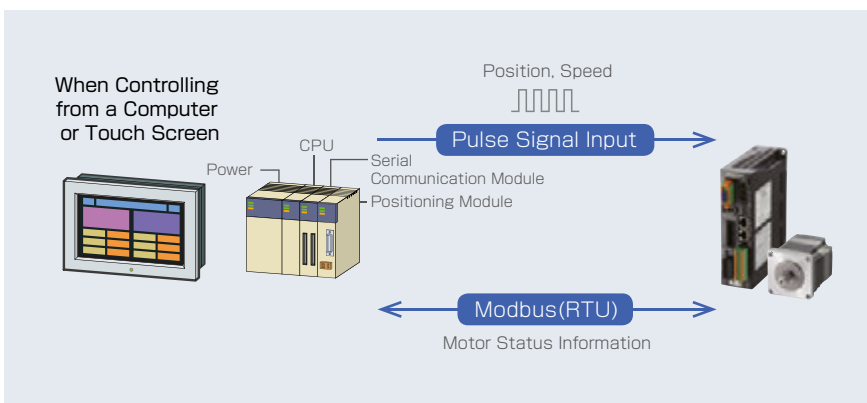



## Pulse-Input Type

AC

DC

The pulse-input type driver is driven by a pulse and direction input from a host PLC. Motion control is carried out via a pulse generator; an add on module to the PLC which must be prepared by the customer.

Basic Settings  
(setting when shipped)

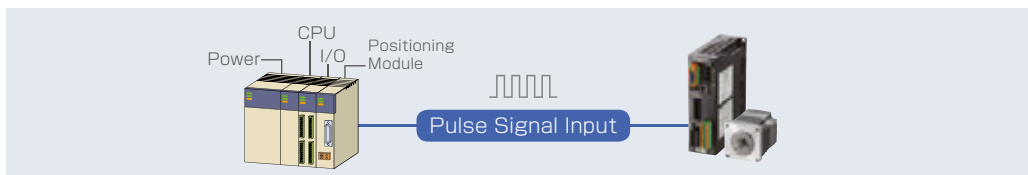

By using the data setting software (**MEXE02**), it is possible to confirm alarm history and monitor the various states.

● Data setting software (**MEXE02**) can be downloaded from the website.

NEW

## Network Compliant Multi-Axis Driver

DC

This multi-axis driver is corresponding to EtherCAT drive profiles.

It can be connected to **AZ** Series DC input motors and to linear actuators equipped with those motors.

Drivers for 2 axes, 3 axes and 4 axes are available.

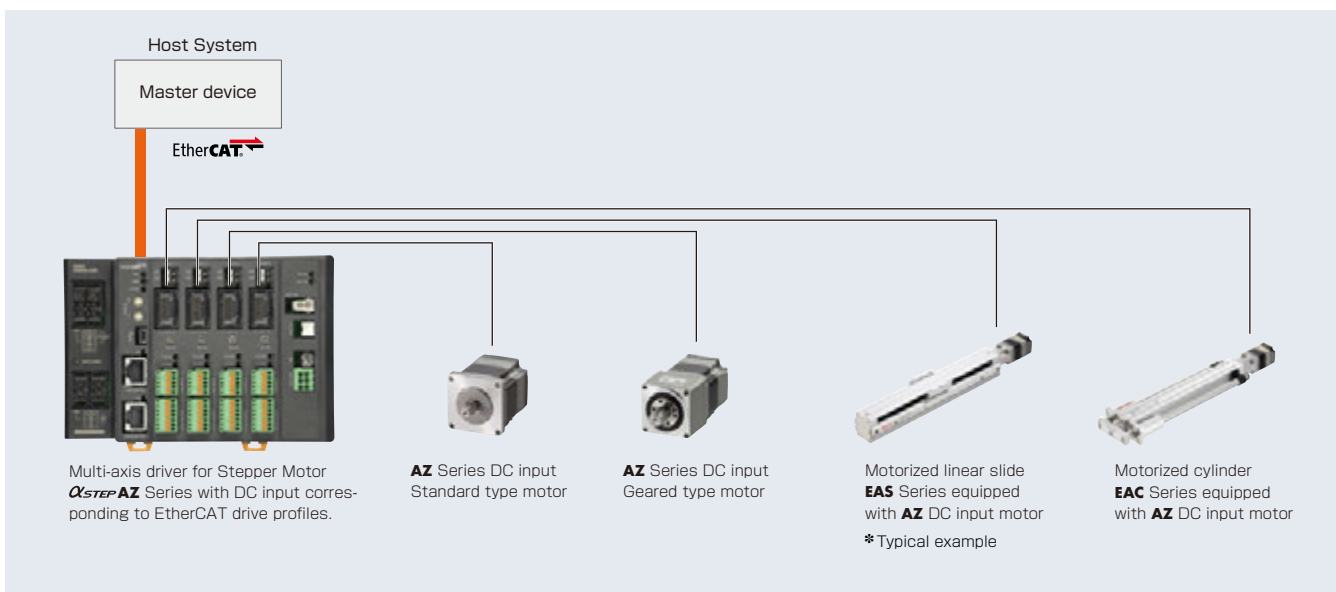

● EtherCAT is registered trademark and patented technology, licensed by Beckhoff Automation GmbH, Germany.  
● Data setting software (**MEXE02**) can be downloaded from the website.

# Simple Settings and Usable Functions that could not be realized without **AZ**

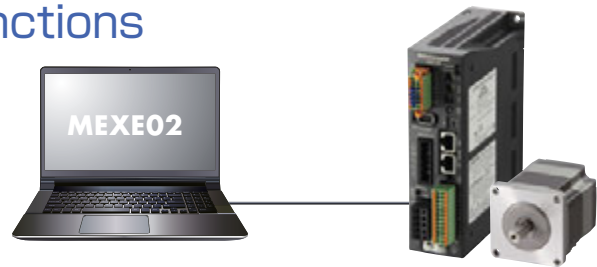

Data setting software **MEXE02**

Data setting software can be downloaded from the website.

## Simple Settings/Easy Operations

By using the **MEXE02** software it is possible to adjust the motor configuration and edit multiple operating and parameter settings. Furthermore, the built-in controller is able to carry out sequential control from multiple inputs or predefined interrupts without requiring a master controller.

### ● Unit-type setting wizard

The units wizard is a function which allows the engineer to input the units they wish to work with. Thereby reducing the burden of converting units when inputting operational data.



### ● A simple system can be realised without a master controller.

The built-in controller type driver can set and execute independently up-to 256 items of operating data, such as motor speed and index length. Furthermore, with sequential control it is possible to form a simple system without a master controller. This is ideal for index and return operations or aligned transportation, such as lifespan / durability tests.

In case of questions please use our free hotline:  
00800 22 55 66 22

## Test Functions

Function for driving the motor independently and with which it is possible to connect with the master control system. By using during device startup, this can help to save time.

### ● Teaching Remote Operation At startup

It is possible to simply set home positions and drive the motor from the data setting software. Before connecting to the master control system, as it can perform teaching and test operations, this contributes to saving time for device startup.

### ● I/O Test At startup When driving

You can perform input signal monitoring and output signal forced output. This is a convenient function for confirming hard wiring with the master control system and the network I/O operation.

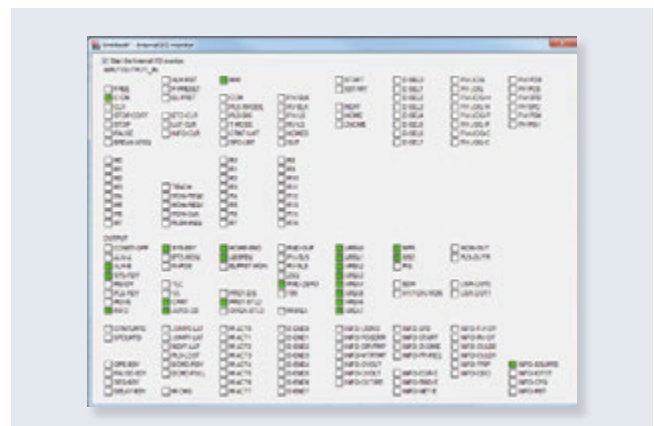
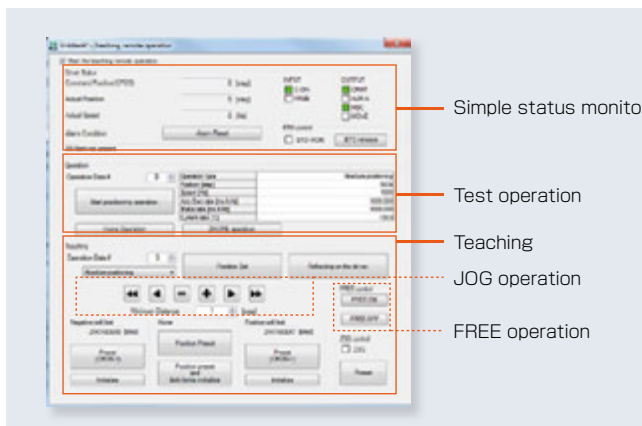

## Monitor Function

Excellent monitor functions are included in order to confirm the motor driving state.

Using differently based on the various scenarios helps with device startup, shortening of adjustment time and efficient maintenance.

### ● Waveform Monitoring At startup

It is possible to monitor the motor driving state and output signal state in the same way as with an oscilloscope. Use this when starting up or adjusting the device.



### ● Alarm Monitoring When driving During maintenance

When an abnormality occurred, it is possible to confirm the content of the abnormality, driving state when it occurred, and countermeasure methods. As the countermeasure method can be confirmed, the abnormality can be handled smoothly.

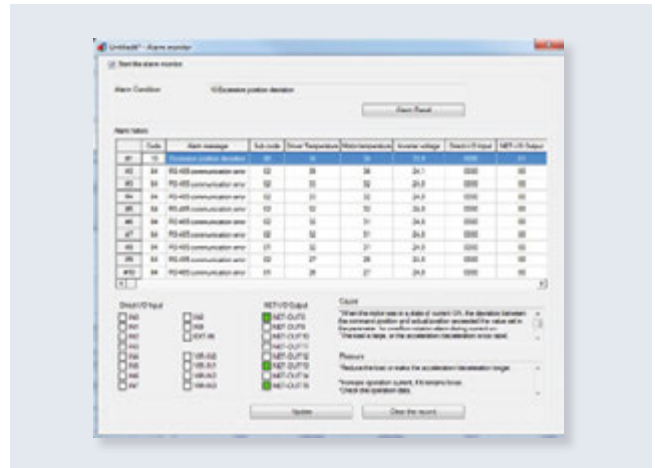

### ● Status Monitoring When driving During maintenance

When driving, it is possible to monitor speed, motor/driver temperature and load rate, as well as total revolutions from start of use. For the various items, as it is possible to set any signal to output, this is effective for efficient maintenance.

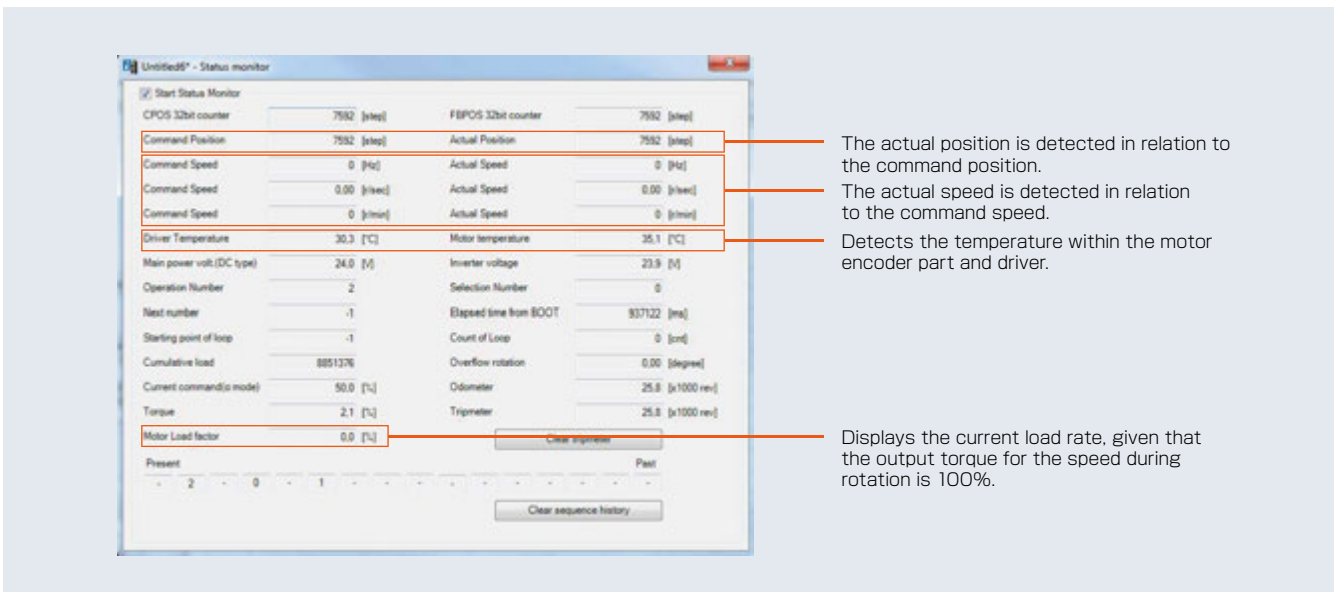



# Lineup

## Motor

AC Single-Phase 200-240 VAC

DC 24/48 VDC

| Type   | Electro-magnetic Brake | Frame Size       |                      |                     |       |                  |
|--|------------------------|------------------|----------------------|---------------------|-------|------------------|
|  |                        | 20mm             | 28mm*6               | 42mm*2              | 60mm  | 85mm 90mm*4      |
| <b>Standard Type</b><br><br>Motor shaft shape<br>One side milled/straight/with key                        | No                     | DC <sup>*1</sup> | DC <sup>*1</sup>     | AC DC               | AC DC | AC               |
|  | Yes                    | —                | —                    | AC DC <sup>*3</sup> | AC DC | AC <sup>*5</sup> |
| <b>TS Geared Type</b><br>(Spur Gear Mechanism)<br>Cable direction can be selected<br>Downward, upward, right, left<br>Low gear ratios, high-speed operations<br>Gear Ratio 7.2, 10, 20, 30 | No                     | —                | —                    | AC DC               | AC DC | AC               |
|  | Yes                    | —                | —                    | AC DC               | AC DC | AC               |
| <b>Right Angle Gearhead FC Geared Type</b><br>(Face Gear Mechanism)<br>Right-angled gearhead for positioning<br>Gear Ratio 7.2, 10, 20, 30   | No                     | —                | —                    | AC DC               | AC DC | —                |
|  | Yes                    | —                | —                    | AC DC               | AC DC | —                |
| <b>PS Geared Type</b><br>(Planetary Gear Mechanism)<br>A wide variety of gear ratios for selecting the desired step angle<br>Gear Ratio 5, 7.2, 10, 25, 36, 50                             | No                     | —                | NEW DC <sup>*1</sup> | AC DC               | AC DC | AC               |
|  | Yes                    | —                | —                    | AC DC               | AC DC | AC               |
| <b>HPG Geared Type</b><br>(Harmonic Drive®)<br><br>High positioning accuracy<br>Gear Ratio 5, 9, 15     | No                     | —                | —                    | AC DC               | AC DC | AC               |
|  | Yes                    | —                | —                    | AC DC               | AC DC | AC               |
| <b>Harmonic Geared Type</b><br>(Harmonic Drive®)<br><br>High positioning accuracy<br>Gear Ratio 50, 100 | No                     | —                | NEW DC <sup>*1</sup> | AC DC               | AC DC | AC               |
|  | Yes                    | —                | —                    | AC DC               | AC DC | AC               |

\*1 24 VDC only \*2 HPG geared type is 40 mm \*3 only for AZM46 \*4 in case of geared type \*5 only for AZM98 \*6 Harmonic gear type is 30 mm

- Notes**
- Please use the above values as reference to see the differences between each type. These values vary depending on the motor frame size and gear ratio.
  - Harmonic planetary, harmonic drive and  are registered trademarks and trademarks of Harmonic Drive Systems Inc.

As a variation on stepper motors, we have prepared a geared motor in which the gears are combined. You can select the optimal type from among each geared motor, considering torque, accuracy (backlash) and price.

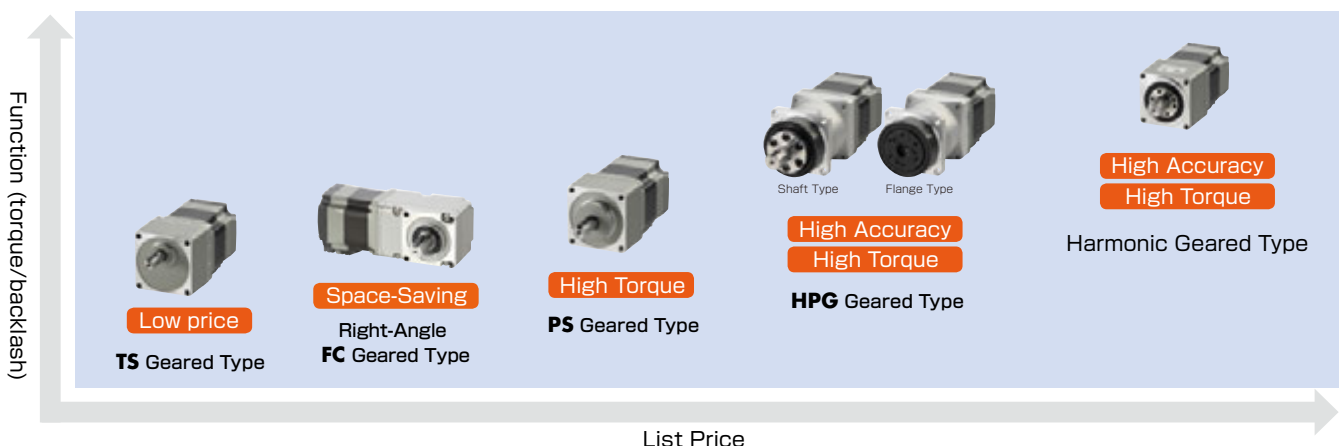

| Permissible Torque, Instantaneous Maximum Torque [N·m]      | Backlash [arcmin] | Basic Resolution [°/pulse] | Output Shaft Rotation Speed [r/min] |
|---|-------------------|----------------------------|-------------------------------------|
| Excitation maximum static torque<br>4                       | —                 | 0.36                       | 6000                                |
| Permissible torque / Instantaneous maximum torque<br>25 45  | 10                | 0.012                      | 833                                 |
| Permissible torque<br>10.5                                  | 10                | 0.012                      | 416                                 |
| Permissible torque / Instantaneous maximum torque<br>37 60  | 7                 | 0.0072                     | 600                                 |
| Permissible torque / Instantaneous maximum torque<br>24 33  | 3                 | 0.024                      | 900                                 |
| Permissible torque / Instantaneous maximum torque<br>52 107 | 0                 | 0.0036                     | 70                                  |

## Driver



Built-in Controller Type **FLEX**



Pulse-Input Type with RS-485 Communication

**NEW**



Pulse-Input Type



Network Compliant Multi-Axis Driver

**NEW**



**EtherCAT**

● **FLEX** is the collective name for products that support I/O control, Modbus (RTU) control and FA network control via network converters.

● **EtherCAT** is a registered trademark for which a license is provided by Beckhoff Automation GmbH in Germany.

## Shaft Shape and Cable Direction can be Selected to the Needs of Application.



One side milled

Straight

With key

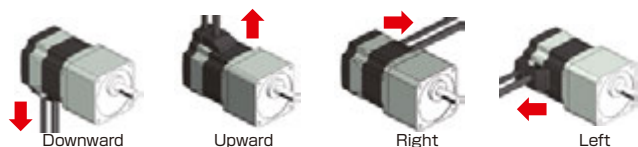

Downward

Upward

Right

Left

The cable direction can be selected out of four directions from the output shaft.

● Standard Type

| Frame Size | Shaft Shape     | <b>NEW</b> | <b>NEW</b> |
|------------|-----------------|------------|------------|
|            | One Side Milled | Straight   | With key   |
| 20mm       | ●               | —          | —          |
| 28mm       | ●               | —          | —          |
| 42mm       | ●               | ●          | ●*         |
| 60mm       | ●               | ●          | ●          |
| 85mm       | ●               | ●          | ●          |

\*AZM48 only

● TS Geared Type

| Frame Size | Cable Direction |        |            |            |
|------------|-----------------|--------|------------|------------|
|            | Downward        | Upward | <b>NEW</b> | <b>NEW</b> |
| 42mm       | ●               | ●      | ●          | ●          |
| 60mm       | ●               | ●      | ●          | ●          |
| 90mm       | ●               | ●      | ●          | ●          |

## System Configuration

### When Combining a Magnetic Brake Type Motor with a Built-in Controller Type Driver or Pulse-Input with RS-485 Communication Driver.

An example of a system configuration when using a built-in controller type driver by I/O or by RS-485. Motor, driver, cables should be ordered separately.

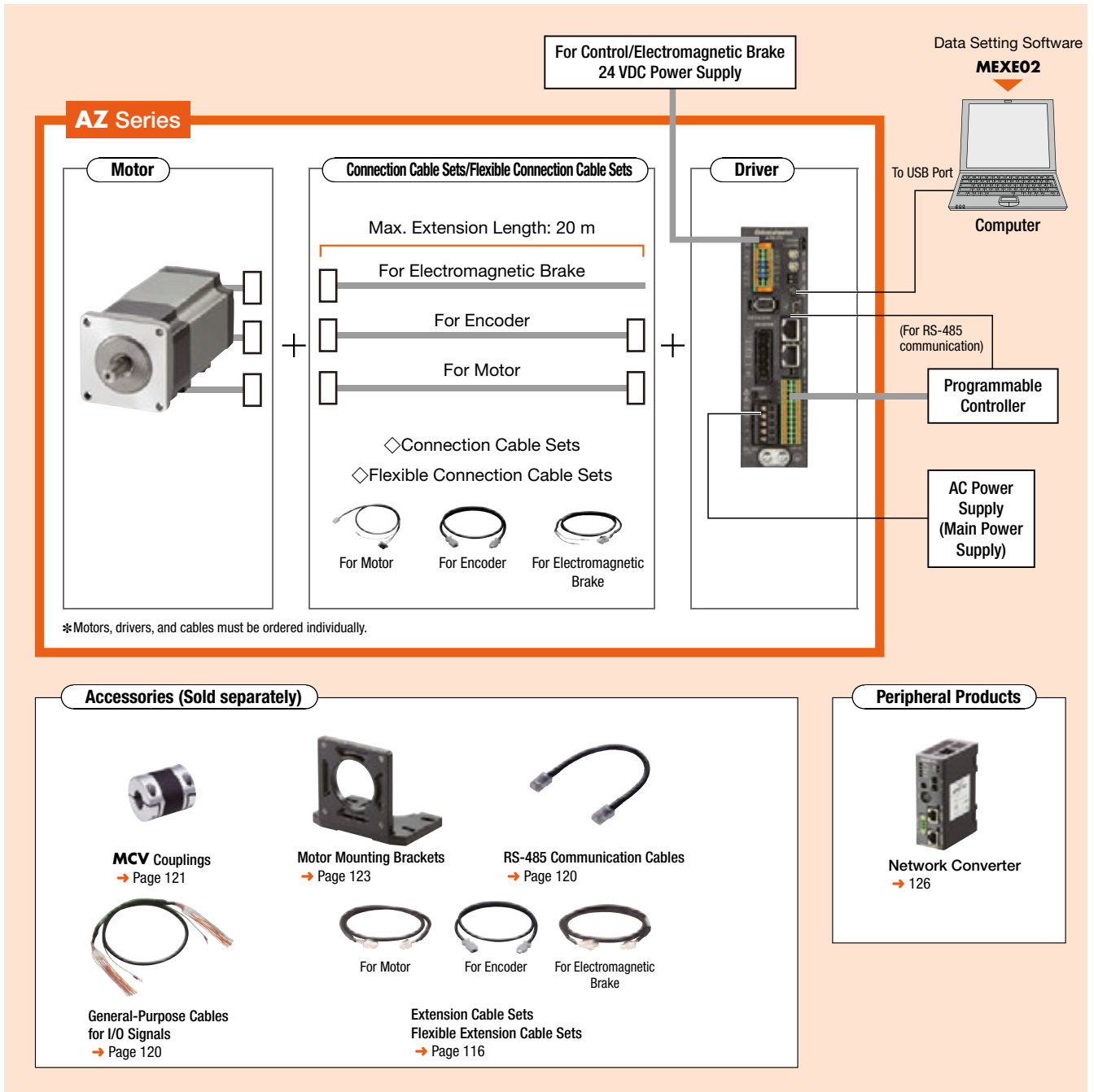

### System configuration price example

| AZ Series      |               |                       | Accessory              |                   |  |
|----------------|---------------|-----------------------|------------------------|-------------------|--|
| Motor          | Driver        | Connection Cable Sets | Sold Separately        |                   |  |
| <b>AZM66MC</b> | <b>AZD-CD</b> | <b>CC030VZFB</b>      | Motor Mounting Bracket | Flexible Coupling | General-Purpose Cables for I/O Signals (1 m) |
| €447.00        | €480.00       | €63.00                | <b>PAL2P-5</b>         | <b>MCV251010</b>  | <b>CC16D010B-1</b>                           |
|                |               |                       | €13.00                 | €53.00            | €18.00                                       |

The system configuration shown above is an example. Other combinations are also available.

#### Note

The motor cable and electromagnetic brake cable from the motor cannot be connected directly to the driver. When connecting to a driver, use a connection cable.

● **Combination of Standard Type Motor with Electromagnetic Brake and Pulse Input Type Driver**

An example of a single-axis system configuration with the SCX11 controller is shown below.

Motors, drivers, and cables must be ordered individually.

\*Not supplied.

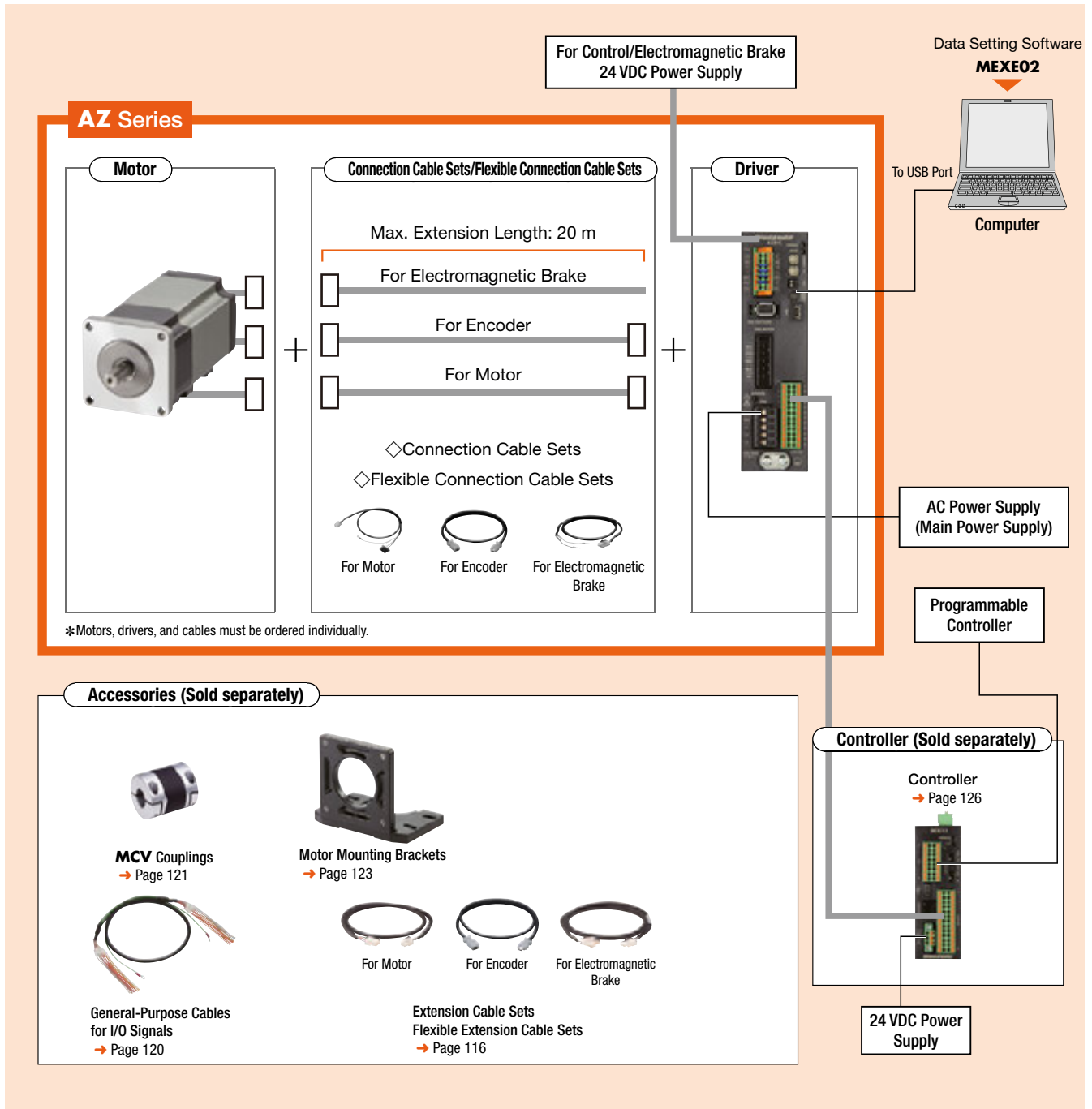

\*Motors, drivers, and cables must be ordered individually.

● **System configuration price example**

| AZ Series      |              |                       | Accessory       |                        |                   |  |
|----------------|--------------|-----------------------|-----------------|------------------------|-------------------|--|
| Motor          | Driver       | Connection Cable Sets | Sold Separately |                        |                   |  |
| <b>AZM66MC</b> | <b>AZD-C</b> | <b>CC030VZFB</b>      | Controller      | Motor Mounting Bracket | Flexible Coupling | General-Purpose Cables for I/O Signals (1 m) |
| €447.00        | €430.00      | €63.00                | <b>SCX11</b>    | <b>PAL2P-5</b>         | <b>MCV251010</b>  | <b>CC16D010B-1</b>                           |
|                |              |                       | €215.00         | €13.00                 | €53.00            | €18.00                                       |

● The system configuration shown above is an example. Other combinations are also available.

**Note**

● The motor cable and electromagnetic brake cable from the motor cannot be connected directly to the driver. When connecting to a driver, use a connection cable.

Features

System Configuration

Product Line

Specifications and Features

Dimensions

Connection and Operation

System Configuration

Product Line

Specifications and Features

Dimensions

Connection and Operation

MultiAxis Driver

Accessories

## Product Number Code

### Motor

#### ◇ Standard Type

**AZM 6 6 A 0 C**

① ② ③ ④ ⑤ ⑥

#### ◇ PS, HPG, Harmonic Geared Type

**AZM 6 6 A C - HP 15 F**

① ② ③ ④ ⑥ ⑦ ⑧ ⑨

#### ◇ TS Geared Type

**AZM 6 6 A C - TS 10 U**

① ② ③ ④ ⑤ ⑥ ⑦ ⑧

#### ◇ FC Geared Type

**AZM 6 6 A C - FC 10 U A**

① ② ③ ④ ⑤ ⑥ ⑦ ⑧ ⑨

### Driver

**AZD - C D**

① ② ③

### Connection Cable Sets/Flexible Connection Cable Sets

**CC 050 V Z F B**

① ② ③ ④ ⑤ ⑥

|   |                     |   |
|---|---------------------|---|
| ① | Motor Type          | <b>AZM: AZ</b> Series Motor   |
| ② | Motor Frame Size    | <b>4:</b> 42 mm ( <b>HPG</b> Geared Type is 40 mm)<br><b>6:</b> 60 mm<br><b>9:</b> 85 mm (Geared Type is 90 mm) |
| ③ | Motor Case Length   |   |
| ④ | Configuration       | <b>A:</b> Single Shaft <b>M:</b> With Electromagnetic Brake   |
| ⑤ | Shaft Shape*        | <b>0:</b> Straight Type <b>1:</b> With Key  |
| ⑥ | Motor Specification | <b>C:</b> AC Power Supply Input Specifications  |
| ⑦ | Geared Type         | <b>PS:</b> PS Geared Type<br><b>HP:</b> HPG Geared Type<br><b>HS:</b> Harmonic Geared Type                      |
| ⑧ | Gear Ratio          |   |
| ⑧ | Output Shaft Type   | <b>HPG</b> Geared Type<br>Blank: Shaft Output <b>F:</b> Flange Output   |

\*For standard types without specified shaft shape one shaft side is milled.

|   |                     |   |
|---|---------------------|---|
| ① | Motor Type          | <b>AZM: AZ</b> Series Motor                                 |
| ② | Motor Frame Size    | <b>4:</b> 42 mm<br><b>6:</b> 60 mm<br><b>9:</b> 90 mm       |
| ③ | Motor Case Length   |   |
| ④ | Configuration       | <b>A:</b> Single Shaft <b>M:</b> With Electromagnetic Brake |
| ⑤ | Motor Specification | <b>C:</b> AC Power Supply Input Specifications              |
| ⑥ | Geared Type         | <b>TS:</b> TS Geared Type                                   |
| ⑦ | Gear Ratio          |   |
| ⑧ | Cable Direction     | <b>U:</b> Up <b>L:</b> Left <b>R:</b> Right                 |

|   |                     |   |
|---|---------------------|---|
| ① | Motor Type          | <b>AZM: AZ</b> Series Motor                                 |
| ② | Motor Frame Size    | <b>4:</b> 42 mm<br><b>6:</b> 60 mm                          |
| ③ | Motor Case Length   |   |
| ④ | Configuration       | <b>A:</b> Single Shaft <b>M:</b> With Electromagnetic Brake |
| ⑤ | Motor Specification | <b>C:</b> AC Power Supply Input Specifications              |
| ⑥ | Geared Type         | <b>FC:</b> FC Geared Type                                   |
| ⑦ | Gear Ratio          |   |
| ⑧ | Cable Direction     | <b>D:</b> Down <b>U:</b> Up                                 |
| ⑨ | Identification      | <b>A:</b> Solid shaft                                       |

\*With the output shaft pointing to the left the cable direction is defined by looking from the gearhead side.

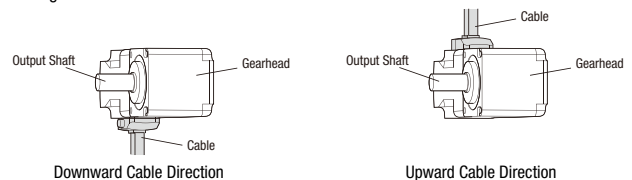

|   |                    |   |
|---|--------------------|---|
| ① | Driver Type        | <b>AZD: AZ</b> Series Driver  |
| ② | Power Supply Input | <b>C:</b> Single-Phase 200~240 VAC  |
| ③ | Type               | <b>D:</b> Built-in Controller Type<br><b>X:</b> Pulse-Input Type with RS-485 Communication<br>Blank: Pulse Input Type |

|   |                       |  |
|---|-----------------------|--|
| ① |                       | <b>CC:</b> Cable   |
| ② | Length                | <b>005:</b> 0.5 m <b>010:</b> 1 m <b>015:</b> 1.5 m <b>020:</b> 2 m<br><b>025:</b> 2.5 m <b>030:</b> 3 m <b>040:</b> 4 m <b>050:</b> 5 m<br><b>070:</b> 7 m <b>100:</b> 10 m <b>150:</b> 15 m <b>200:</b> 20 m |
| ③ | Reference Number      |  |
| ④ | Applicable Models     | <b>Z:</b> AZ Series  |
| ⑤ | Cable Type            | <b>F:</b> Connection Cable Sets<br><b>R:</b> Flexible Connection Cable Sets  |
| ⑥ | Electromagnetic Brake | Blank: Without Electromagnetic Brake<br><b>B:</b> With Electromagnetic Brake   |

\*WARNING: Connecting the AZ to three-phase 400 VAC will damage the product



## Product Line

For the single-phase 100-120 VAC models and three-phase 200-240 VAC models, please contact the nearest Oriental Motor sales office.

### Motor

#### ◇ Standard Type



| Frame Size | Product Name                        | List Price |
|------------|-------------------------------------|------------|
| 42 mm      | <b>AZM46AC</b><br><b>AZM46AOC</b>   | €246.00    |
|            | <b>AZM48AC</b><br><b>AZM48AOC</b>   | €255.00    |
|            | <b>AZM48A1C</b>                     | €265.00    |
| 60 mm      | <b>AZM66AC</b><br><b>AZM66AOC</b>   | €290.00    |
|            | <b>AZM66A1C</b>                     | 290.00     |
|            | <b>AZM69AC</b><br><b>AZM69AOC</b>   | €295.00    |
|            | <b>AZM69A1C</b>                     | €304.00    |
| 85 mm      | <b>AZM98AC</b><br><b>AZM98AOC</b>   | €315.00    |
|            | <b>AZM98A1C</b>                     | € 324.00   |
|            | <b>AZM911AC</b><br><b>AZM911AOC</b> | €333.00    |
|            | <b>AZM911A1C</b>                    | € 342.00   |

#### ◇ Standard Type with Electromagnetic Brake



| Frame Size | Product Name                      | List Price |
|------------|-----------------------------------|------------|
| 42 mm      | <b>AZM46MC</b><br><b>AZM46MOC</b> | €368.00    |
| 60 mm      | <b>AZM66MC</b><br><b>AZM66MOC</b> | €447.00    |
|            | <b>AZM66M1C</b>                   | € 447.00   |
|            | <b>AZM69MC</b><br><b>AZM69MOC</b> | €452.00    |
| 85 mm      | <b>AZM69M1C</b>                   | € 460.00   |
|            | <b>AZM98MC</b><br><b>AZM98MOC</b> | €489.00    |
|            | <b>AZM98M1C</b>                   | € 497.00   |

#### ◇ TS Geared Type



| Frame Size | Product Name                                 | Gear Ratio                                   | List Price             |
|------------|--|--|------------------------|
| 42 mm      | <b>AZM46AC-TS</b> □◇<br><b>AZM46AC-TS</b> □◇ | 3.6, 7.2<br>10, 20, 30                       | €341.00<br>€351.00     |
|            | 60 mm  | <b>AZM66AC-TS</b> □◇<br><b>AZM66AC-TS</b> □◇ | 3.6, 7.2<br>10, 20, 30 |
| 90 mm      |  | <b>AZM98AC-TS</b> □◇<br><b>AZM98AC-TS</b> □◇ | 3.6, 7.2<br>10, 20, 30 |

#### ◇ TS Geared Type with Electromagnetic Brake



| Frame Size | Product Name                                 | Gear Ratio                                   | List Price             |
|------------|--|--|------------------------|
| 42 mm      | <b>AZM46MC-TS</b> □◇<br><b>AZM46MC-TS</b> □◇ | 3.6, 7.2<br>10, 20, 30                       | €463.00<br>€473.00     |
|            | 60 mm  | <b>AZM66MC-TS</b> □◇<br><b>AZM66MC-TS</b> □◇ | 3.6, 7.2<br>10, 20, 30 |
| 90 mm      |  | <b>AZM98MC-TS</b> □◇<br><b>AZM98MC-TS</b> □◇ | 3.6, 7.2<br>10, 20, 30 |

#### ◇ FC Geared Type



| Frame Size | Product Name                                   | Gear Ratio                                     | List Price         |
|------------|--|--|--------------------|
| 42 mm      | <b>AZM46AC-FC</b> □UA<br><b>AZM46AC-FC</b> □DA | 7.2, 10,<br>20, 30                             | € 451,00           |
|            | 60 mm  | <b>AZM66AC-FC</b> □UA<br><b>AZM66AC-FC</b> □DA | 7.2, 10,<br>20, 30 |

#### ◇ FC Geared Type with Electromagnetic Brake



| Frame Size | Product Name                                   | Gear Ratio                                     | List Price         |
|------------|--|--|--------------------|
| 42 mm      | <b>AZM46MC-FC</b> □UA<br><b>AZM46MC-FC</b> □DA | 7.2, 10,<br>20, 30                             | € 573,00           |
|            | 60 mm  | <b>AZM66MC-FC</b> □UA<br><b>AZM66MC-FC</b> □DA | 7.2, 10,<br>20, 30 |

#### ◇ PS Geared Type



| Frame Size | Product Name                               | Gear Ratio                                 | List Price               |
|------------|--|--|--------------------------|
| 42 mm      | <b>AZM46AC-PS</b> □<br><b>AZM46AC-PS</b> □ | 5, 7.2, 10<br>25, 36, 50                   | €413.00<br>€450.00       |
|            | 60 mm                                      | <b>AZM66AC-PS</b> □<br><b>AZM66AC-PS</b> □ | 5, 7.2, 10<br>25, 36, 50 |
| 90 mm      |  | <b>AZM98AC-PS</b> □<br><b>AZM98AC-PS</b> □ | 5, 7.2, 10<br>25, 36, 50 |

#### ◇ PS Geared Type with Electromagnetic Brake



| Frame Size | Product Name                               | Gear Ratio                                 | List Price               |
|------------|--|--|--------------------------|
| 42 mm      | <b>AZM46MC-PS</b> □<br><b>AZM46MC-PS</b> □ | 5, 7.2, 10<br>25, 36, 50                   | €535.00<br>€572.00       |
|            | 60 mm                                      | <b>AZM66MC-PS</b> □<br><b>AZM66MC-PS</b> □ | 5, 7.2, 10<br>25, 36, 50 |
| 90 mm      |  | <b>AZM98MC-PS</b> □<br><b>AZM98MC-PS</b> □ | 5, 7.2, 10<br>25, 36, 50 |

● A number indicating the gear ratio is entered where the box □ is located in the product name.  
● Either **R** (right), **L** (left) or **U** (up) is entered for the cable withdrawing direction in ◇ in the product name.



◇ **HPG Geared Type**

| Frame Size | Product Name         | List Price |
|------------|----------------------|------------|
| 40 mm      | <b>AZM46AC-HP5</b>   | €526.00    |
|            | <b>AZM46AC-HP5F</b>  | €516.00    |
|            | <b>AZM46AC-HP9</b>   | €526.00    |
|            | <b>AZM46AC-HP9F</b>  | €516.00    |
| 60 mm      | <b>AZM66AC-HP5</b>   | €710.00    |
|            | <b>AZM66AC-HP5F</b>  | €695.00    |
|            | <b>AZM66AC-HP15</b>  | €835.00    |
|            | <b>AZM66AC-HP15F</b> | €820.00    |
| 90 mm      | <b>AZM98AC-HP5</b>   | €895.00    |
|            | <b>AZM98AC-HP5F</b>  | €875.00    |
|            | <b>AZM98AC-HP15</b>  | €990.00    |
|            | <b>AZM98AC-HP15F</b> | €970.00    |



◇ **HPG Geared Type with Electromagnetic Brake**

| Frame Size | Product Name         | List Price |
|------------|----------------------|------------|
| 40 mm      | <b>AZM46MC-HP5</b>   | €648.00    |
|            | <b>AZM46MC-HP5F</b>  | €638.00    |
|            | <b>AZM46MC-HP9</b>   | €648.00    |
|            | <b>AZM46MC-HP9F</b>  | €638.00    |
| 60 mm      | <b>AZM66MC-HP5</b>   | €867.00    |
|            | <b>AZM66MC-HP5F</b>  | €852.00    |
|            | <b>AZM66MC-HP15</b>  | €992.00    |
|            | <b>AZM66MC-HP15F</b> | €977.00    |
| 90 mm      | <b>AZM98MC-HP5</b>   | €1,069.00  |
|            | <b>AZM98MC-HP5F</b>  | €1,049.00  |
|            | <b>AZM98MC-HP15</b>  | €1,164.00  |
|            | <b>AZM98MC-HP15F</b> | €1,144.00  |



◇ **Harmonic Geared Type**

| Frame Size | Product Name        | Gear Ratio | List Price |
|------------|---------------------|------------|------------|
| 42 mm      | <b>AZM46AC-HS</b> □ | 50, 100    | €701.00    |
| 60 mm      | <b>AZM66AC-HS</b> □ |            | €945.00    |
| 90 mm      | <b>AZM98AC-HS</b> □ |            | €1,135.00  |



◇ **Harmonic Geared Type with Electromagnetic Brake**

| Frame Size | Product Name        | Gear Ratio | List Price |
|------------|---------------------|------------|------------|
| 42 mm      | <b>AZM46MC-HS50</b> | 50, 100    | €823.00    |
| 60 mm      | <b>AZM66MC-HS50</b> |            | €1,102.00  |
| 90 mm      | <b>AZM98MC-HS50</b> |            | €1,309.00  |

● **Driver**

◇ **Built-in Controller Type**

| Power Supply Input       | Product Name  | List Price |
|--------------------------|---------------|------------|
| Single-Phase 200-240 VAC | <b>AZD-CD</b> | €480.00    |



◇ **Pulse-Input Type with RS-485 Communication**

| Power Supply Input       | Product Name  | List Price |
|--------------------------|---------------|------------|
| Single-Phase 200-240 VAC | <b>AZD-CX</b> | €480.00    |



◇ **Pulse Input Type**

| Power Supply Input       | Product Name | List Price |
|--------------------------|--------------|------------|
| Single-Phase 200-240 VAC | <b>AZD-C</b> | €430.00    |



## ● Connection Cable Sets/Flexible Connection Cable Sets

Use the flexible connection cable in applications where the cable is bent and flexed repeatedly. To extend the connection cables extension cables and flexible extension cables are provided. Please see page 116.

The motor cable and electromagnetic brake cable from the motor cannot be connected directly to the driver. Use a connection cable to connect the driver.



For Motor For Encoder

### ◇ Without Electromagnetic Brake

| Product Line                   | Length L (m) | Product Name    | List Price |
|--------------------------------|--------------|-----------------|------------|
| Connection Cable Sets          | 0.5          | <b>CC005VZF</b> | €29.00     |
|                                | 1            | <b>CC010VZF</b> | €29.00     |
|                                | 1.5          | <b>CC015VZF</b> | €33.00     |
|                                | 2            | <b>CC020VZF</b> | €38.00     |
|                                | 2.5          | <b>CC025VZF</b> | €43.00     |
|                                | 3            | <b>CC030VZF</b> | €48.00     |
|                                | 4            | <b>CC040VZF</b> | €75.00     |
|                                | 5            | <b>CC050VZF</b> | €84.00     |
|                                | 7            | <b>CC070VZF</b> | €104.00    |
|                                | 10           | <b>CC100VZF</b> | €135.00    |
|                                | 15           | <b>CC150VZF</b> | €187.00    |
|                                | 20           | <b>CC200VZF</b> | €237.00    |
| Flexible Connection Cable Sets | 0.5          | <b>CC005VZR</b> | €65.00     |
|                                | 1            | <b>CC010VZR</b> | €65.00     |
|                                | 1.5          | <b>CC015VZR</b> | €70.00     |
|                                | 2            | <b>CC020VZR</b> | €76.00     |
|                                | 2.5          | <b>CC025VZR</b> | €80.00     |
|                                | 3            | <b>CC030VZR</b> | €85.00     |
|                                | 4            | <b>CC040VZR</b> | €97.00     |
|                                | 5            | <b>CC050VZR</b> | €108.00    |
|                                | 7            | <b>CC070VZR</b> | €137.00    |
|                                | 10           | <b>CC100VZR</b> | €181.00    |
|                                | 15           | <b>CC150VZR</b> | €262.00    |
|                                | 20           | <b>CC200VZR</b> | €326.00    |



For Motor For Encoder For Electromagnetic Brake

### ◇ Type with an Electromagnetic Brake

| Product Line                   | Length L (m) | Product Name     | List Price |
|--------------------------------|--------------|------------------|------------|
| Connection Cable Sets          | 0.5          | <b>CC005VZFB</b> | €40.00     |
|                                | 1            | <b>CC010VZFB</b> | €40.00     |
|                                | 1.5          | <b>CC015VZFB</b> | €46.00     |
|                                | 2            | <b>CC020VZFB</b> | €52.00     |
|                                | 2.5          | <b>CC025VZFB</b> | €57.00     |
|                                | 3            | <b>CC030VZFB</b> | €63.00     |
|                                | 4            | <b>CC040VZFB</b> | €93.00     |
|                                | 5            | <b>CC050VZFB</b> | €103.00    |
|                                | 7            | <b>CC070VZFB</b> | €127.00    |
|                                | 10           | <b>CC100VZFB</b> | €163.00    |
|                                | 15           | <b>CC150VZFB</b> | €225.00    |
|                                | 20           | <b>CC200VZFB</b> | €285.00    |
| Flexible Connection Cable Sets | 0.5          | <b>CC005VZRB</b> | €87.00     |
|                                | 1            | <b>CC010VZRB</b> | €87.00     |
|                                | 1.5          | <b>CC015VZRB</b> | €95.00     |
|                                | 2            | <b>CC020VZRB</b> | €103.00    |
|                                | 2.5          | <b>CC025VZRB</b> | €109.00    |
|                                | 3            | <b>CC030VZRB</b> | €115.00    |
|                                | 4            | <b>CC040VZRB</b> | €131.00    |
|                                | 5            | <b>CC050VZRB</b> | €146.00    |
|                                | 7            | <b>CC070VZRB</b> | €184.00    |
|                                | 10           | <b>CC100VZRB</b> | €237.00    |
|                                | 15           | <b>CC150VZRB</b> | €331.00    |
|                                | 20           | <b>CC200VZRB</b> | €422.00    |

## ■ Included

### ● Motor

| Type              | Included         | Parallel Key | Motor Installation Screw | Operating Manual |
|-------------------|------------------|--------------|--------------------------|------------------|
| Standard          | —                | —            | —                        | 1 Copy           |
| <b>TS</b> Geared  | Frame Size 42 mm | —            | —                        |                  |
|                   | Frame Size 60 mm | 1 Piece      | M4×60 P0.7 (4 Screws)    |                  |
|                   | Frame Size 90 mm | 1 Piece      | M8×90 P1.25 (4 Screws)   |                  |
| <b>FC</b> Geared  | 1 Piece          | —            | —                        |                  |
| <b>PS</b> Geared  | 1 Piece          | —            | —                        |                  |
| <b>HPG</b> Geared | Shaft Output     | 1 Piece      | —                        |                  |
|                   | Flange Output    | —            | —                        |                  |
| Harmonic Geared   | 1 Piece          | —            | —                        |                  |

● For the functions and operation of the product please refer to the operating manual (function edition). The function edition is not included in the product, please contact the nearest sales office or download it from the website.

### ● Driver

| Type   | Included | Connector   | Operating Manual |
|--|----------|---|------------------|
| Built-in Controller Type<br>Pulse Input Type | —        | <ul style="list-style-type: none"> <li>• Connector for CN4 (1 Piece)</li> <li>• Connector for CN1 (1 Piece)</li> <li>• Connector for CN5 (1 Piece)</li> <li>• Connector Wiring Lever (1 Piece)</li> </ul> | 1 Copy           |

### ● Connection Cable Sets / Flexible Connection Cable Sets

| Type  | Included | Operating Manual |
|---|----------|------------------|
| Connection Cable Sets<br>Flexible Connection Cable Sets | —        | 1 Copy           |

## Output Power of Stepper Motors (Reference Values)

The output power (W) of AC servomotors is displayed as rated torque, i.e. the output power (W) when rotating at rated speed.

On the other hand, as stepper motors featuring with high positioning accuracy and high torque at low and medium speeds don't have a rated speed, the rated output power cannot be displayed. For reference it is shown below which torque of the **AZ** Series Standard Type is equivalent to which rated torque of the servomotor.

| AZ Series (Standard Type) |               |               | Equivalent Rated Torque of Servomotor (Reference Value) |
|---------------------------|---------------|---------------|---|
| Frame Size                | Product Name  | Price         |   |
| 42mm                      | <b>AZM46</b>  | from € 706.00 | Equivalent to Rated Torque of 50-100 W                  |
|                           | <b>AZM48</b>  | from € 714.00 |   |
| 60mm                      | <b>AZM66</b>  | from € 750.00 | Equivalent to Rated Torque of 100-200 W                 |
|                           | <b>AZM69</b>  | from € 755.00 | Equivalent to Rated Torque of 200-400 W                 |
| 85mm                      | <b>AZM98</b>  | from € 775.00 | Equivalent to Rated Torque of 400-750 W                 |
|                           | <b>AZM911</b> | from € 793.00 |   |

\*Total price for motor, driver and 1 m connection cable.

### ● Frame Size 42mm

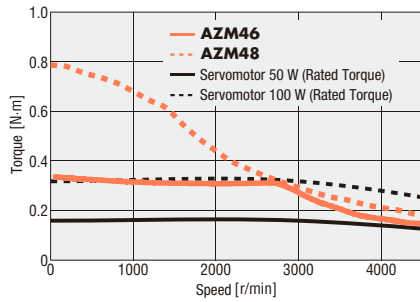

### ● Frame Size 60mm

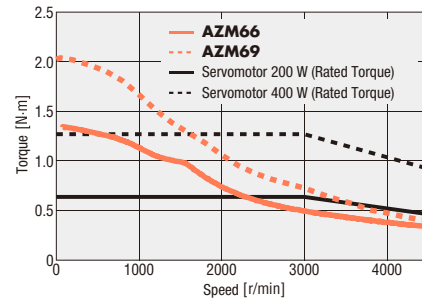

### ● Frame Size 85mm

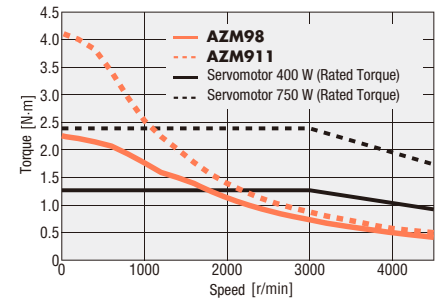

● Data for the speed-torque characteristics is based on Oriental Motor's internal measurement conditions. If the conditions are changed, the characteristics may also change as a result.

# Standard Type Frame Size 42 mm, 60 mm, 85 mm

## Specifications



| Motor Product Name                 | Single Shaft                               | AZM46A□C   | AZM48A□C             | AZM66A□C   | AZM69A□C   | AZM98A□C   | AZM911A□C             |
|------------------------------------|--|--|----------------------|--|--|--|-----------------------|
|                                    | With Electromagnetic Brake                 | AZM46M□C   | —                    | AZM66M□C   | AZM69M□C   | AZM98M□C   | —                     |
| Driver Product Name                | Built-in Controller Type                   | AZD-CD (Single-Phase 200-240 VAC)                |                      |  |  |  |                       |
|                                    | Pulse-Input Type with RS-485 Communication | AZD-CX (Single-Phase 200-240 VAC)                |                      |  |  |  |                       |
|                                    | Pulse Input Type                           | AZD-C (Single-Phase 200-240 VAC)                 |                      |  |  |  |                       |
| Maximum Holding Torque             | N·m  | 0.3  | 0.77                 | 1.2  | 2  | 2  | 4                     |
| Holding Torque at Motor Standstill | Power ON                                   | N·m  | 0.15                 | 0.38   | 0.6  | 1  | 2                     |
|                                    | With Electromagnetic Brake                 | N·m  | 0.15                 | —  | 0.6  | 1  | —                     |
| Rotor Inertia                      | J: kg·m <sup>2</sup>                       | $55 \times 10^{-7}$<br>( $71 \times 10^{-7}$ )*1 | $115 \times 10^{-7}$ | $370 \times 10^{-7}$<br>( $530 \times 10^{-7}$ )*1 | $740 \times 10^{-7}$<br>( $900 \times 10^{-7}$ )*1 | $1090 \times 10^{-7}$<br>( $1250 \times 10^{-7}$ )*1 | $2200 \times 10^{-7}$ |
| Resolution                         | Resolution Setting: 1000 P/R               | 0.36°/Pulse                                      |                      |  |  |  |                       |
| Power Supply Input                 | Voltage and Frequency                      | Single-Phase 200-240 VAC -15~+6% 50/60 Hz        |                      |  |  |  |                       |
|                                    | Input Current                              | A  | 1.7                  | 1.6  | 2.3  | 3.3  | 3.3                   |
| Control Power Supply               |  | 24 VDC ±5%*2<br>0.25 A (0.33 A)*1                | 24 VDC ±5%<br>0.25 A | 24 VDC ±5%*2<br>0.25 A (0.5 A)*1                   |  |  |                       |

● Either **0** (straight) or **1** (with key) indicating the shaft shape is entered where the box □ is located in the product name. (For **AZM46** straight only). For the one side milled shaft shape no number is specified.

\*1 The brackets ( ) indicate the specifications for the product with an electromagnetic brake.

\*2 For the type with an electromagnetic brake, a 24 VDC±4% specification applies if the wiring distance between the motor and driver is extended to 20 m using a cable.

## Speed - Torque Characteristics (Reference Value)

**AZM46**

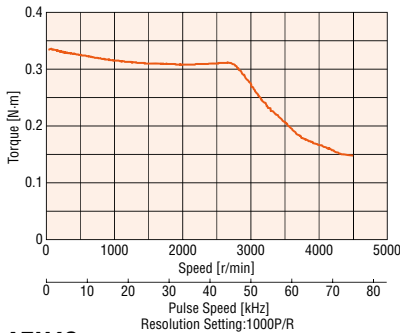

**AZM48**

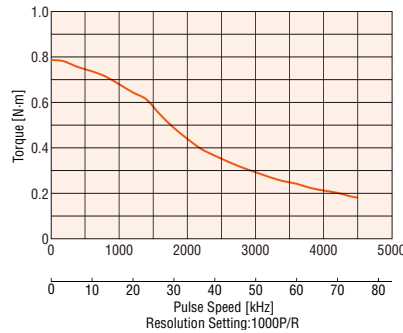

**AZM66**

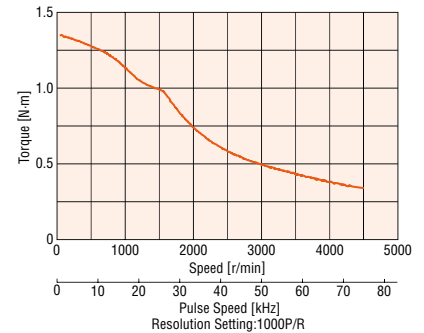

**AZM69**

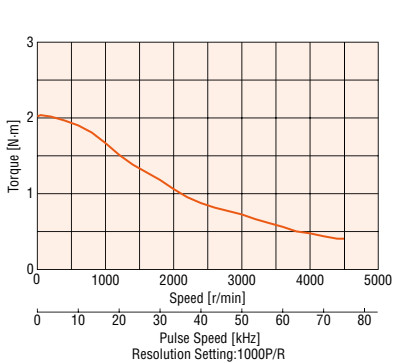

**AZM98**

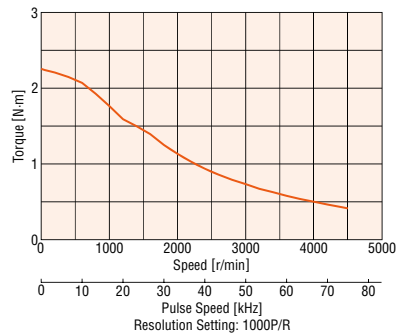

**AZM911**

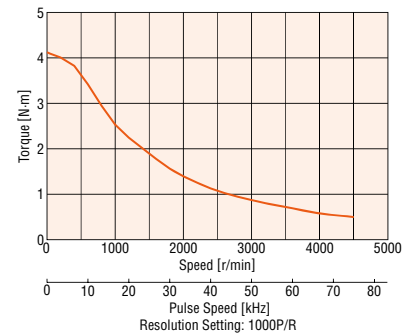

### Notes

- The speed-torque characteristics are data based upon our measurement conditions. When these conditions change, these characteristics may change.
- Depending on the driving conditions, a considerable amount of heat may be generated by the motor. Be sure to keep the motor case temperature at 80°C or less in order to protect the ABZO sensor. (When conforming to the UL standards, it is required to keep the temperature of the motor case at 75°C or less, since the motor is recognized as thermal class A.)

## Explanation of Terms in Specifications Table

|                              |  |  |
|------------------------------|--|--|
| Maximum Holding Torque       | The maximum holding torque (holding force) the motor has when power (rated current) is being supplied but the motor shaft is at standstill. (With geared types, the value of holding torque considers the permissible strength of the gear.) |  |
| Permissible Torque           | This is the maximum torque continuously applied to the gear output shaft.  |  |
| Max. Instantaneous Torque    | This is the maximum torque that can be applied to the gear output shaft during acceleration/deceleration, such as when an inertial load is started and stopped.  |  |
| Holding Torque at Standstill | When Power is ON   | This is the holding torque when the automatic current cutback function is activated.   |
|                              | Electromagnetic Brake  | This is the static friction torque that the electromagnetic brake can generate at rest. (Electromagnetic brake is power off activated type.) |

# TS Geared Type Frame Size 42 mm

## Specifications



| Motor Product Name           | Single Shaft                               | AZM46AC-TS3.6                                | AZM46AC-TS7.2 | AZM46AC-TS10 | AZM46AC-TS20 | AZM46AC-TS30 |     |
|------------------------------|--|--|---------------|--------------|--------------|--------------|-----|
|                              | With Electromagnetic Brake                 | AZM46MC-TS3.6                                | AZM46MC-TS7.2 | AZM46MC-TS10 | AZM46MC-TS20 | AZM46MC-TS30 |     |
| Driver Product Name          | Built-in Controller Type                   | AZD-CD (Single-Phase 200-240 VAC)            |               |              |              |              |     |
|                              | Pulse-Input Type with RS-485 Communication | AZD-CX (Single-Phase 200-240 VAC)            |               |              |              |              |     |
|                              | Pulse Input Type                           | AZD-C (Single-Phase 200-240 VAC)             |               |              |              |              |     |
| Maximum Holding Torque       | N·m  | 0.65   | 1.2           | 1.7          | 2            | 2.3          |     |
| Rotor Inertia                | J: kg·m <sup>2</sup>                       | 55×10 <sup>-7</sup> (71×10 <sup>-7</sup> )*1 |               |              |              |              |     |
| Gear Ratio                   |  | 3.6  | 7.2           | 10           | 20           | 30           |     |
| Resolution                   | Resolution Setting: 1000P/R                | 0.1°/Pulse                                   | 0.05°/Pulse   | 0.036°/Pulse | 0.018°/Pulse | 0.012°/Pulse |     |
| Permissible Torque           | N·m  | 0.65   | 1.2           | 1.7          | 2            | 2.3          |     |
| Maximum Instantaneous Torque | N·m  | 0.85   | 1.6           | 2            | 3            |              |     |
| Holding Torque at            | Power ON                                   | N·m  | 0.54          | 1            | 1.5          | 1.9          | 2.2 |
| Motor Standstill             | With Electromagnetic Brake                 | N·m  | 0.54          | 1            | 1.5          | 1.9          | 2.2 |
| Speed Range                  | r/min                                      | 0~833  | 0~416         | 0~300        | 0~150        | 0~100        |     |
| Backlash                     | arcmin                                     | 45 (0.75)                                    | 25 (0.42)     |              | 15 (0.25)    |              |     |
| Power Supply Input           | Voltage and Frequency                      | Single-Phase 200-240 VAC -15~+6% 50/60 Hz    |               |              |              |              |     |
|                              | Input Current                              | A 1.7  |               |              |              |              |     |
| Control Power Supply         |  | 24 VDC ±5%*2 0.25 A (0.33 A)*1               |               |              |              |              |     |

● Either **R** (right), **U** (up) or **L** (left) indicating the cable withdrawing direction is entered where the box  is located within the product name. For the downward direction no letter is entered in the box .

\*1 The brackets ( ) indicate the specifications for the product with an electromagnetic brake.

\*2 For the type with an electromagnetic brake, a 24 VDC±4% specification applies if the wiring distance between the motor and driver is extended to 20 m using a cable.

## Speed - Torque Characteristics (Reference Value)

**AZM46 Gear Ratio 3.6**

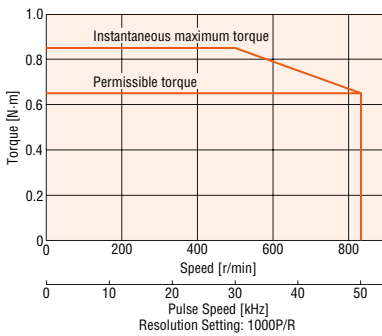

**AZM46 Gear Ratio 7.2**

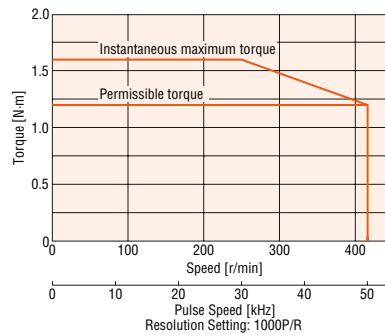

**AZM46 Gear Ratio 10**

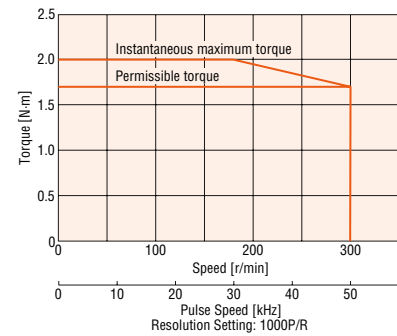

**AZM46 Gear Ratio 20**

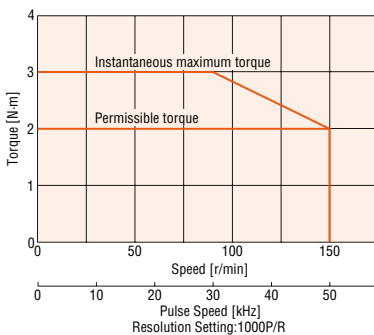

**AZM46 Gear Ratio 30**

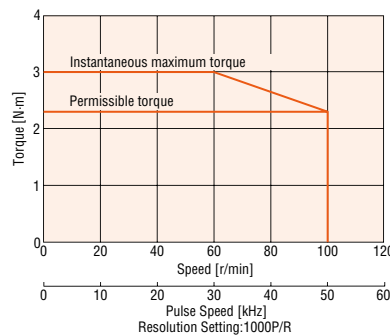

### Notes

- The speed-torque characteristics are data based upon our measurement conditions. When these conditions change, these characteristics may change.
- Depending on the driving conditions, a considerable amount of heat may be generated by the motor. Be sure to keep the motor case temperature at 80°C or less in order to protect the ABZO sensor. (When conforming to the UL standards, it is required to keep the temperature of the motor case at 75°C or less, since the motor is recognized as thermal class A.)

# TS Geared Type Frame Size 60 mm

## Specifications



| Motor Product Name                         | Single Shaft                | AZM66AC-TS3.6                                  | AZM66AC-TS7.2 | AZM66AC-TS10 | AZM66AC-TS20 | AZM66AC-TS30 |   |
|--|-----------------------------|--|---------------|--------------|--------------|--------------|---|
| With Electromagnetic Brake                 |                             | AZM66MC-TS3.6                                  | AZM66MC-TS7.2 | AZM66MC-TS10 | AZM66MC-TS20 | AZM66MC-TS30 |   |
| Driver Product Name                        | Built-in Controller Type    | AZD-CD (Single-Phase 200-240 VAC)              |               |              |              |              |   |
| Pulse-Input Type with RS-485 Communication |                             | AZD-CX (Single-Phase 200-240 VAC)              |               |              |              |              |   |
| Pulse Input Type                           |                             | AZD-C (Single-Phase 200-240 VAC)               |               |              |              |              |   |
| Maximum Holding Torque                     | N·m                         | 1.8  | 3             | 4            | 5            | 6            |   |
| Rotor Inertia                              | J: kg·m <sup>2</sup>        | 370×10 <sup>-7</sup> (530×10 <sup>-7</sup> )*1 |               |              |              |              |   |
| Gear Ratio                                 |                             | 3.6  | 7.2           | 10           | 20           | 30           |   |
| Resolution                                 | Resolution Setting: 1000P/R | 0.1°/Pulse                                     | 0.05°/Pulse   | 0.036°/Pulse | 0.018°/Pulse | 0.012°/Pulse |   |
| Permissible Torque                         | N·m                         | 1.8  | 3             | 4            | 5            | 6            |   |
| Maximum Instantaneous Torque*              | N·m                         | *  | 4.5           | 6            | 8            | 10           |   |
| Holding Torque at Motor Standstill         | Power ON                    | N·m  | 1.3           | 2.6          | 3.7          | 5            | 6 |
| With Electromagnetic Brake                 | N·m                         | 1.3  | 2.6           | 3.7          | 5            | 6            |   |
| Speed Range                                | r/min                       | 0~833  | 0~416         | 0~300        | 0~150        | 0~100        |   |
| Backlash                                   | arcmin                      | 35 (0.59)                                      | 15 (0.25)     |              | 10 (0.17)    |              |   |
| Power Supply Input                         | Voltage and Frequency       | Single-Phase 200-240 VAC -15~+6% 50/60 Hz      |               |              |              |              |   |
| Input Current                              | A                           | 2.3  |               |              |              |              |   |
| Control Power Supply                       |                             | 24 VDC ±5%*2 0.25 A (0.5 A)*1                  |               |              |              |              |   |

\* For the geared motor output torque, refer to the speed – torque characteristics.

● Either **R** (right), **U** (up) or **L** (left) indicating the cable withdrawing direction is entered where the box □ is located within the product name. For the downward direction no letter is entered in the box □.

\*1 The brackets ( ) indicate the specifications for the product with an electromagnetic brake.

\*2 For the type with an electromagnetic brake, a 24 VDC±4% specification applies if the wiring distance between the motor and driver is extended to 20 m using a cable.

## Speed - Torque Characteristics (Reference Value)

**AZM66 Gear Ratio 3.6**

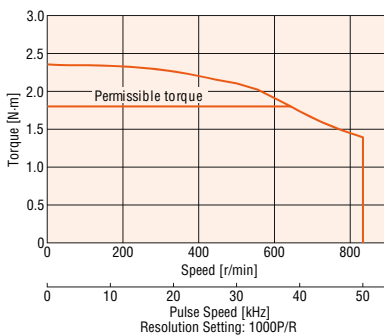

**AZM66 Gear Ratio 7.2**

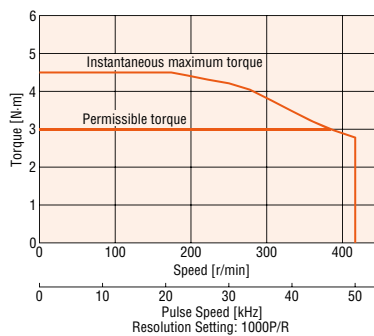

**AZM66 Gear Ratio 10**

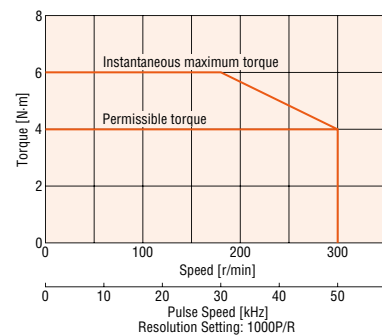

**AZM66 Gear Ratio 20**

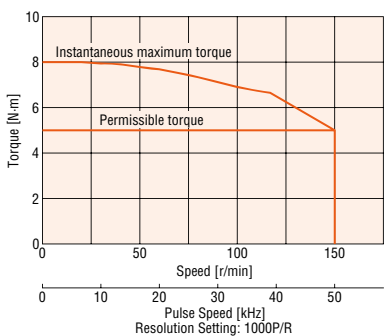

**AZM66 Gear Ratio 30**

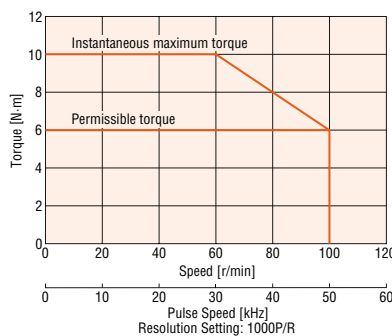

### Notes

- The speed-torque characteristics are data based upon our measurement conditions. When these conditions change, these characteristics may change.
- Depending on the driving conditions, a considerable amount of heat may be generated by the motor. Be sure to keep the motor case temperature at 80°C or less in order to protect the ABZO sensor. (When conforming to the UL standards, it is required to keep the temperature of the motor case at 75°C or less, since the motor is recognized as thermal class A.)

# TS Geared Type Frame Size 90 mm



## Specifications

|                               |  |  |   |  |  |  |    |
|-------------------------------|--|--|---|--|--|--|----|
| Motor Product Name            | Single Shaft                               | <b>AZM98AC-TS3.6</b> <input type="checkbox"/>                | <b>AZM98AC-TS7.2</b> <input type="checkbox"/> | <b>AZM98AC-TS10</b> <input type="checkbox"/> | <b>AZM98AC-TS20</b> <input type="checkbox"/> | <b>AZM98AC-TS30</b> <input type="checkbox"/> |    |
|                               | With Electromagnetic Brake                 | <b>AZM98MC-TS3.6</b> <input type="checkbox"/>                | <b>AZM98MC-TS7.2</b> <input type="checkbox"/> | <b>AZM98MC-TS10</b> <input type="checkbox"/> | <b>AZM98MC-TS20</b> <input type="checkbox"/> | <b>AZM98MC-TS30</b> <input type="checkbox"/> |    |
| Driver Product Name           | Built-in Controller Type                   | <b>AZD-CD</b> (Single-Phase 200-240 VAC)                     |   |  |  |  |    |
|                               | Pulse-Input Type with RS-485 Communication | <b>AZD-CX</b> (Single-Phase 200-240 VAC)                     |   |  |  |  |    |
|                               | Pulse Input Type                           | <b>AZD-C</b> (Single-Phase 200-240 VAC)                      |   |  |  |  |    |
| Maximum Holding Torque        | N·m  | 6  | 10  | 14   | 20   | 25   |    |
| Rotor Inertia                 | J: kg·m <sup>2</sup>                       | 1090×10 <sup>-7</sup> (1250×10 <sup>-7</sup> )* <sup>1</sup> |   |  |  |  |    |
| Gear Ratio                    |  | 3.6  | 7.2   | 10   | 20   | 30   |    |
| Resolution                    | Resolution Setting: 1000 P/R               | 0.1°/Pulse   | 0.05°/Pulse                                   | 0.036°/Pulse                                 | 0.018°/Pulse                                 | 0.012°/Pulse                                 |    |
| Permissible Torque            | N·m  | 6  | 10  | 14   | 20   | 25   |    |
| Maximum Instantaneous Torque* | N·m  | *  | *   | 20   | *  | 45   |    |
| Holding Torque at             | Power ON                                   | N·m  | 3.6   | 7.2  | 10   | 20   | 25 |
| Motor Standstill              | With Electromagnetic Brake                 | N·m  | 3.6   | 7.2  | 10   | 20   | 25 |
| Speed Range                   | r/min                                      | 0~833  | 0~416   | 0~300  | 0~150  | 0~100  |    |
| Backlash                      | arcmin                                     | 25 (0.42)  | 15 (0.25)                                     |  | 10 (0.17)                                    |  |    |
| Power Supply Input            | Voltage and Frequency                      | Single-Phase 200-240 VAC -15~+6% 50/60 Hz                    |   |  |  |  |    |
|                               | Input Current                              | A 3.3  |   |  |  |  |    |
| Control Power Supply          |  | 24 VDC ±5%* <sup>2</sup> 0.25 A (0.5 A)* <sup>1</sup>        |   |  |  |  |    |

\* For the geared motor output torque, refer to the speed – torque characteristics.

● Either **R** (right), **U** (up) or **L** (left) indicating the cable withdrawing direction is entered where the box  is located within the product name. For the downward direction no letter is entered in the box .

\*<sup>1</sup> The brackets ( ) indicate the specifications for the product with an electromagnetic brake.

\*<sup>2</sup> For the type with an electromagnetic brake, a 24 VDC±4% specification applies if the wiring distance between the motor and driver is extended to 20 m using a cable.

## Speed - Torque Characteristics (Reference Value)

**AZM98 Gear Ratio 3.6**

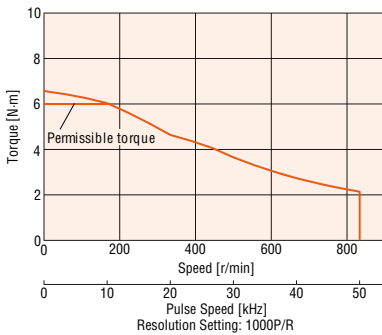

**AZM98 Gear Ratio 7.2**

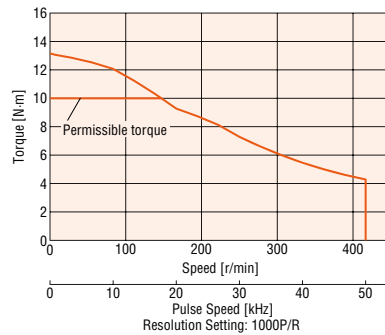

**AZM98 Gear Ratio 10**

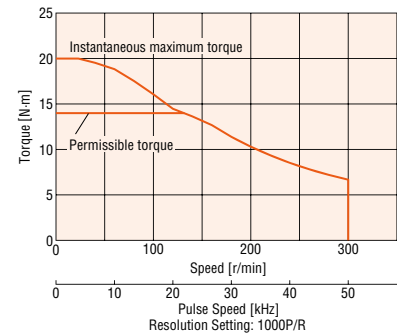

**AZM98 Gear Ratio 20**

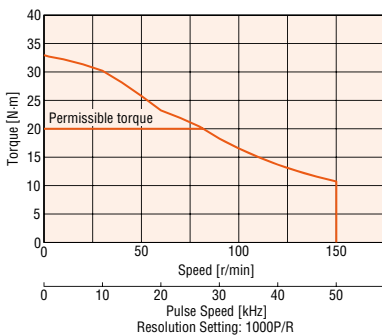

**AZM98 Gear Ratio 30**

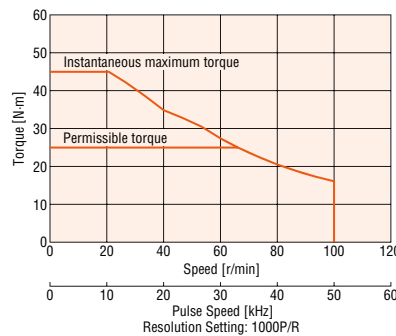

### Notes

- The speed-torque characteristics are data based upon our measurement conditions. When these conditions change, these characteristics may change.
- Depending on the driving conditions, a considerable amount of heat may be generated by the motor. Be sure to keep the motor case temperature at 80°C or less in order to protect the ABZO sensor. (When conforming to the UL standards, it is required to keep the temperature of the motor case at 75°C or less, since the motor is recognized as thermal class A.)



# FC Geared Type Frame Size 42 mm

## Specifications



| Motor Product Name     | Single Shaft                               | AZM46AC-FC7.2□A                              | AZM46AC-FC10□A | AZM46AC-FC20□A | AZM46AC-FC30□A |   |
|------------------------|--|--|----------------|----------------|----------------|---|
|                        | With Electromagnetic Brake                 | AZM46MC-FC7.2□A                              | AZM46MC-FC10□A | AZM46MC-FC20□A | AZM46MC-FC30□A |   |
| Driver Product Name    | Built-in Controller Type                   | AZD-CD (Single-Phase 200-240 VAC)            |                |                |                |   |
|                        | Pulse Input Type with RS-485 Communication | AZD-CX (Single-Phase 200-240 VAC)            |                |                |                |   |
|                        | Pulse Input Type                           | AZD-C (Single-Phase 200-240 VAC)             |                |                |                |   |
| Maximum Holding Torque | N·m  | 0.7  | 1              | 2              | 3              |   |
| Rotor Inertia          | J: kg·m <sup>2</sup>                       | 55×10 <sup>-7</sup> (71×10 <sup>-7</sup> )*1 |                |                |                |   |
| Gear Ratio             |  | 7.2  | 10             | 20             | 30             |   |
| Resolution             | Resolution Setting: 1000P/R                | 0.05°/Pulse                                  | 0.036°/Pulse   | 0.018°/Pulse   | 0.012°/Pulse   |   |
| Permissible Torque     | N·m  | 0.7  | 1              | 2              | 3              |   |
| Holding Torque at      | Power ON                                   | N·m  | 0.7            | 1              | 2              | 3 |
| Motor Standstill       | With Electromagnetic Brake                 | N·m  | 0.7            | 1              | 2              | 3 |
| Speed Range            | r/min                                      | 0~416  | 0~300          | 0~150          | 0~100          |   |
| Backlash               | arcmin                                     | 25 (0.42°)                                   |                | 15 (0.25°)     |                |   |
| Power Supply Input     | Voltage and Frequency                      | Single-Phase 200-240 VAC -15~+6% 50/60 Hz    |                |                |                |   |
|                        | Input Current                              | 1.7  |                |                |                |   |
| Control Power Supply   |  | 24 VDC ±5%*2 0.25 A (0.5 A)*1                |                |                |                |   |

● Either **U** (up) or **D** (down) indicating the cable withdrawing direction is entered where the box □ is located within the product name.

\*1 The brackets ( ) indicate the specifications for the product with an electromagnetic brake.

\*2 For the type with an electromagnetic brake, a 24 VDC ±4% specification applies if the wiring distance between the motor and driver is extended to 20 m using a cable.

## Speed - Torque Characteristics (Reference Value)

**AZM46 Gear Ratio 7.2**

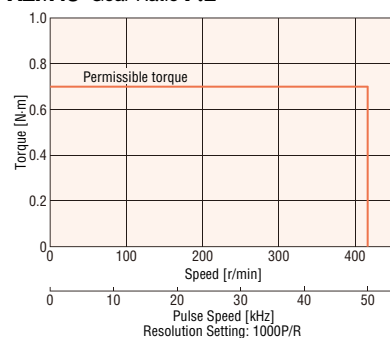

**AZM46 Gear Ratio 10**

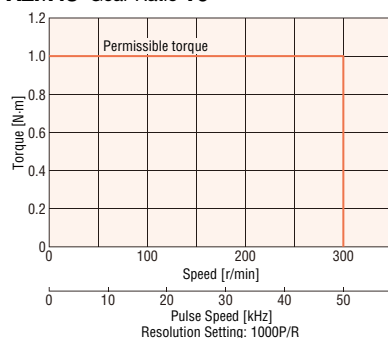

**AZM46 Gear Ratio 20**

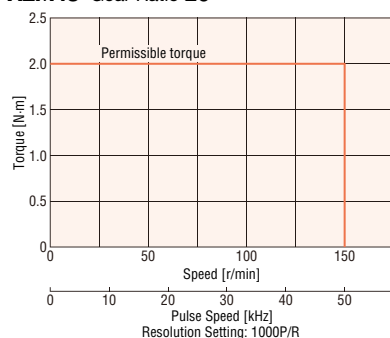

**AZM46 Gear Ratio 30**

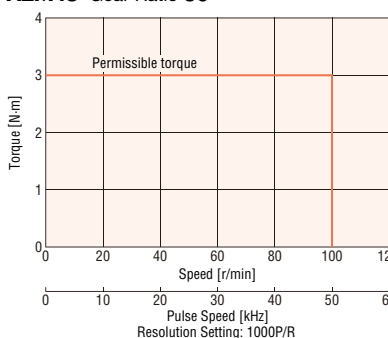

### Notes

● The speed-torque characteristics are data based upon our measurement conditions. When these conditions change, these characteristics may change.

● Depending on the driving conditions, a considerable amount of heat may be generated by the motor. Be sure to keep the motor case temperature at 80°C or less in order to protect the ABZO sensor. (When conforming to the UL standards, it is required to keep the temperature of the motor case at 75°C or less, since the motor is recognized as thermal class A.)

Features

System Configuration

Product Line

Specifications and Features

AC Input

Dimensions

Connection and Operation

System Configuration

Product Line

Specifications and Features

DC Input

Dimensions

Connection and Operation

Multiaxis Driver

Accessories

# FC Geared Type Frame Size 60 mm



## Specifications

|                        |  |  |                        |                        |                        |    |
|------------------------|--|--|------------------------|------------------------|------------------------|----|
| Motor Product Name     | Single Shaft                               | <b>AZM66AC-FC7.2</b> □A                        | <b>AZM66AC-FC10</b> □A | <b>AZM66AC-FC20</b> □A | <b>AZM66AC-FC30</b> □A |    |
|                        | With Electromagnetic Brake                 | <b>AZM66MC-FC7.2</b> □A                        | <b>AZM66MC-FC10</b> □A | <b>AZM66MC-FC20</b> □A | <b>AZM66MC-FC30</b> □A |    |
| Driver Product Name    | Built-in Controller Type                   | <b>AZD-CD</b> (Single-Phase 200-240 VAC)       |                        |                        |                        |    |
|                        | Pulse-Input Type with RS-485 Communication | <b>AZD-CX</b> (Single-Phase 200-240 VAC)       |                        |                        |                        |    |
|                        | Pulse Input Type                           | <b>AZD-C</b> (Single-Phase 200-240 VAC)        |                        |                        |                        |    |
| Maximum Holding Torque | N·m  | 2.5  | 3.5                    | 7                      | 10                     |    |
| Rotor Inertia          | J: kg·m <sup>2</sup>                       | 370×10 <sup>-7</sup> (530×10 <sup>-7</sup> )*1 |                        |                        |                        |    |
| Gear Ratio             |  | 7.2  | 10                     | 20                     | 30                     |    |
| Resolution             | Resolution Setting: 1000P/R                | 0.05°/Pulse                                    | 0.036°/Pulse           | 0.018°/Pulse           | 0.012°/Pulse           |    |
| Permissible Torque     | N·m  | 2.5  | 3.5                    | 7                      | 10                     |    |
| Holding Torque at      | Power ON                                   | N·m  | 2.5                    | 3.5                    | 7                      | 10 |
| Motor Standstill       | With Electromagnetic Brake                 | N·m  | 2.5                    | 3.5                    | 7                      | 10 |
| Speed Range            | r/min                                      | 0~416  | 0~300                  | 0~150                  | 0~100                  |    |
| Backlash               | arcmin                                     | 15 (0.25°)                                     |                        | 10 (0.17°)             |                        |    |
| Power Supply Input     | Voltage and Frequency                      | Single-Phase 200-240 VAC -15~+6% 50/60 Hz      |                        |                        |                        |    |
|                        | Input Current                              | A 2.3  |                        |                        |                        |    |
| Control Power Supply   |  | 24 VDC ±5%*2 0.25 A (0.5 A)*1                  |                        |                        |                        |    |

● Either **U** (up) or **D** (down) indicating the cable withdrawing direction is entered where the box □ is located within the product name.

\*1 The brackets ( ) indicate the specifications for the product with an electromagnetic brake.

\*2 For the type with an electromagnetic brake, a 24 VDC±4% specification applies if the wiring distance between the motor and driver is extended to 20 m using a cable.

## Speed - Torque Characteristics (Reference Value)

**AZM66 Gear Ratio 7.2**

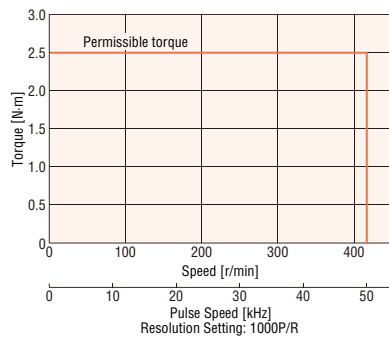

**AZM66 Gear Ratio 10**

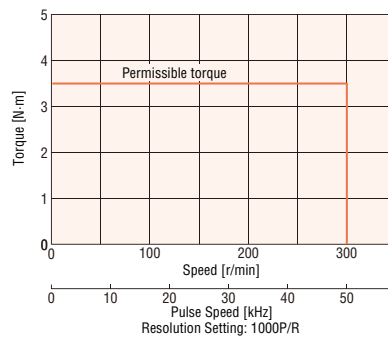

**AZM66 Gear Ratio 20**

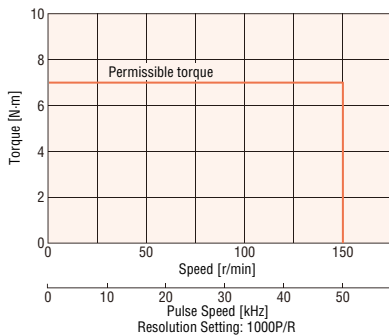

**AZM66 Gear Ratio 30**

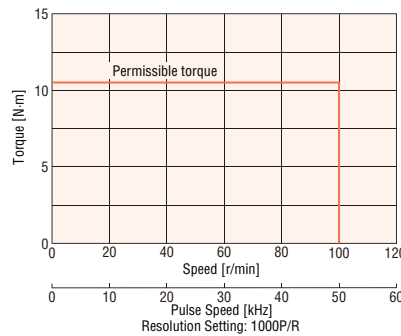

### Notes

● The speed-torque characteristics are data based upon our measurement conditions. When these conditions change, these characteristics may change.

● Depending on the driving conditions, a considerable amount of heat may be generated by the motor. Be sure to keep the motor case temperature at 80°C or less in order to protect the ABZO sensor. (When conforming to the UL standards, it is required to keep the temperature of the motor case at 75°C or less, since the motor is recognized as thermal class A.)

# PS Geared Type Frame Size 42 mm

## Specifications



| Motor Product Name                 | Single Shaft                               | AZM46AC-PS5                                  | AZM46AC-PS7.2 | AZM46AC-PS10 | AZM46AC-PS25  | AZM46AC-PS36 | AZM46AC-PS50  |
|------------------------------------|--|--|---------------|--------------|---------------|--------------|---------------|
|                                    | With Electromagnetic Brake                 | AZM46MC-PS5                                  | AZM46MC-PS7.2 | AZM46MC-PS10 | AZM46MC-PS25  | AZM46MC-PS36 | AZM46MC-PS50  |
| Driver Product Name                | Built-in Controller Type                   | AZD-CD (Single-Phase 200-240 VAC)            |               |              |               |              |               |
|                                    | Pulse-Input Type with RS-485 Communication | AZD-CX (Single-Phase 200-240 VAC)            |               |              |               |              |               |
|                                    | Pulse Input Type                           | AZD-C (Single-Phase 200-240 VAC)             |               |              |               |              |               |
| Maximum Holding Torque             | N·m  | 1  | 1.5           | 2.5          | 3             |              |               |
| Rotor Inertia                      | J: kg·m <sup>2</sup>                       | 55×10 <sup>-7</sup> (71×10 <sup>-7</sup> )*1 |               |              |               |              |               |
| Gear Ratio                         |  | 5  | 7.2           | 10           | 25            | 36           | 50            |
| Resolution                         | Resolution Setting: 1000P/R                | 0.072°/Pulse                                 | 0.05°/Pulse   | 0.036°/Pulse | 0.0144°/Pulse | 0.01°/Pulse  | 0.0072°/Pulse |
| Permissible Torque                 | N·m  | 1  | 1.5           | 2.5          | 3             |              |               |
| Maximum Instantaneous Torque       | N·m  | 1.5  | 2             |              | 6             |              |               |
| Holding Torque at Motor Standstill | Power ON                                   | N·m  | 0.75          | 1            | 1.5           | 2.5          | 3             |
|                                    | With Electromagnetic Brake                 | N·m  | 0.75          | 1            | 1.5           | 2.5          | 3             |
| Speed Range                        | r/min                                      | 0~600  | 0~416         | 0~300        | 0~120         | 0~83         | 0~60          |
| Backlash                           | arcmin                                     | 15 (0.25°)                                   |               |              |               |              |               |
| Power Supply Input                 | Voltage and Frequency                      | Single-Phase 200-240 VAC -15~+6% 50/60 Hz    |               |              |               |              |               |
|                                    | Input Current                              | A  | 1.7           |              |               |              |               |
| Control Power Supply               |  | 24 VDC ±5%*2 0.25 A (0.33 A)*1               |               |              |               |              |               |

\*1 The brackets ( ) indicate the specifications for the product with an electromagnetic brake.

\*2 For the type with an electromagnetic brake, a 24 VDC±4% specification applies if the wiring distance between the motor and driver is extended to 20 m using a cable.

## Speed - Torque Characteristics (Reference Value)

**AZ46 Gear Ratio 5**

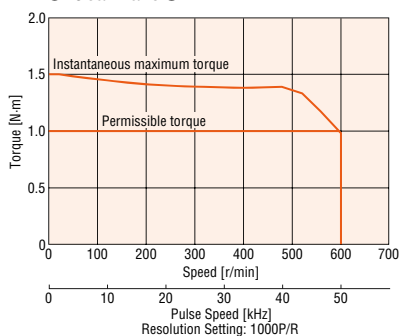

**AZ46 Gear Ratio 7.2**

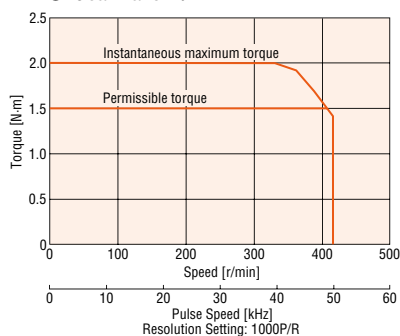

**AZ46 Gear Ratio 10**

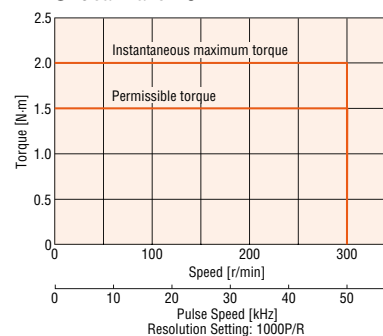

**AZ46 Gear Ratio 25**

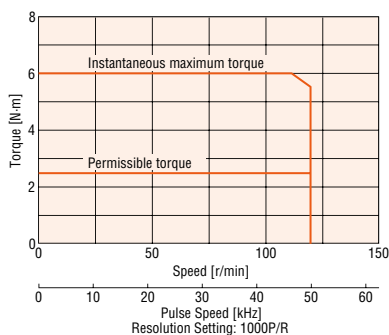

**AZ46 Gear Ratio 36**

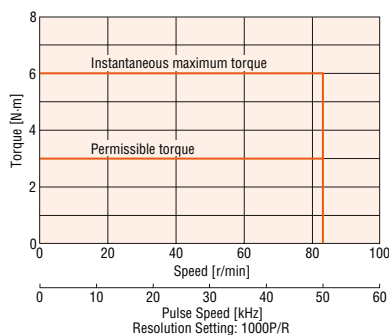

**AZ46 Gear Ratio 50**

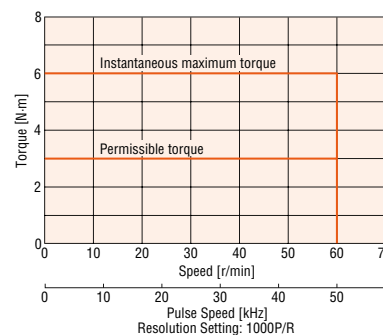

### Notes

- The speed-torque characteristics are data based upon our measurement conditions. When these conditions change, these characteristics may change.
- Depending on the driving conditions, a considerable amount of heat may be generated by the motor. Be sure to keep the motor case temperature at 80°C or less in order to protect the ABZO sensor. (When conforming to the UL standards, it is required to keep the temperature of the motor case at 75°C or less, since the motor is recognized as thermal class A.)

Features

System Configuration

Product Line

Specifications and Features

AC Input

Dimensions

Connection and Operation

System Configuration

Product Line

Specifications and Features

DC Input

Dimensions

Connection and Operation

Multiaxis Driver

Accessories

# PS Geared Type Frame Size 60 mm



## Specifications

| Motor Product Name                         | Single Shaft                | AZM66AC-PS5                                    | AZM66AC-PS7.2 | AZM66AC-PS10 | AZM66AC-PS25  | AZM66AC-PS36 | AZM66AC-PS50  |
|--|-----------------------------|--|---------------|--------------|---------------|--------------|---------------|
| With Electromagnetic Brake                 |                             | AZM66MC-PS5                                    | AZM66MC-PS7.2 | AZM66MC-PS10 | AZM66MC-PS25  | AZM66MC-PS36 | AZM66MC-PS50  |
| Driver Product Name                        | Built-in Controller Type    | AZD-CD (Single-Phase 200-240 VAC)              |               |              |               |              |               |
| Pulse-Input Type with RS-485 Communication |                             | AZD-CX (Single-Phase 200-240 VAC)              |               |              |               |              |               |
| Pulse Input Type                           |                             | AZD-C (Single-Phase 200-240 VAC)               |               |              |               |              |               |
| Maximum Holding Torque                     | N·m                         | 3.5  | 4             | 5            | 8             |              |               |
| Rotor Inertia                              | J: kg·m <sup>2</sup>        | 370×10 <sup>-7</sup> (530×10 <sup>-7</sup> )*1 |               |              |               |              |               |
| Gear Ratio                                 |                             | 5  | 7.2           | 10           | 25            | 36           | 50            |
| Resolution                                 | Resolution Setting: 1000P/R | 0.072°/Pulse                                   | 0.05°/Pulse   | 0.036°/Pulse | 0.0144°/Pulse | 0.01°/Pulse  | 0.0072°/Pulse |
| Permissible Torque                         | N·m                         | 3.5  | 4             | 5            | 8             |              |               |
| Maximum Instantaneous Torque*              | N·m                         | *  | *             | 11           | 16            | 20           |               |
| Holding Torque at Motor Standstill         | Power ON                    | N·m  | 3             | 4            | 5             | 8            |               |
| With Electromagnetic Brake                 | N·m                         | 3  | 4             | 5            | 8             |              |               |
| Speed Range                                | r/min                       | 0~600  | 0~416         | 0~300        | 0~120         | 0~83         | 0~60          |
| Backlash                                   | arcmin                      | 7 (0.12°)                                      |               |              | 9 (0.15°)     |              |               |
| Power Supply Input                         | Voltage and Frequency       | Single-Phase 200-240 VAC -15~+6% 50/60 Hz      |               |              |               |              |               |
| Input Current                              | A                           | 2.3  |               |              |               |              |               |
| Control Power Supply                       |                             | 24 VDC ±5%*2 0.25 A (0.5 A)*1                  |               |              |               |              |               |

\* For the geared motor output torque, refer to the speed – torque characteristics.

\*1 The brackets ( ) indicate the specifications for the product with an electromagnetic brake.

\*2 For the type with an electromagnetic brake, a 24 VDC±4% specification applies if the wiring distance between the motor and driver is extended to 20 m using a cable.

## Speed - Torque Characteristics (Reference Value)

**AZ66 Gear Ratio 5**

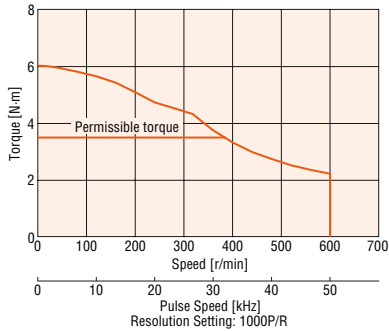

**AZ66 Gear Ratio 7.2**

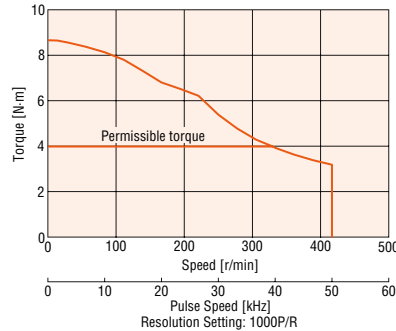

**AZ66 Gear Ratio 10**

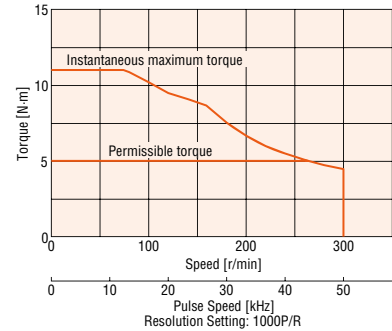

**AZ66 Gear Ratio 25**

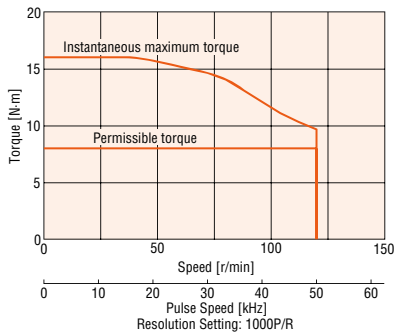

**AZ66 Gear Ratio 36**

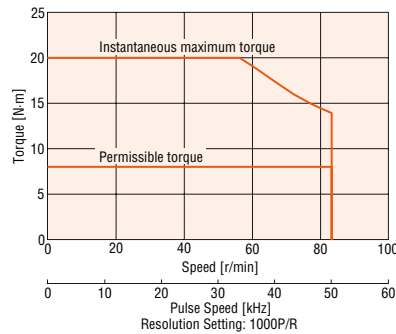

**AZ66 Gear Ratio 50**

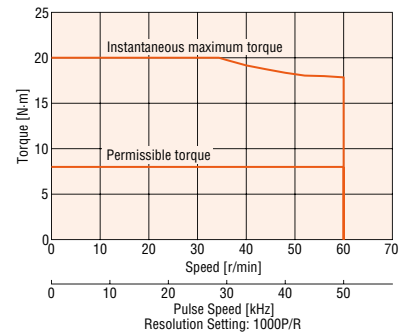

### Notes

- The speed-torque characteristics are data based upon our measurement conditions. When these conditions change, these characteristics may change.
- Depending on the driving conditions, a considerable amount of heat may be generated by the motor. Be sure to keep the motor case temperature at 80°C or less in order to protect the ABZO sensor. (When conforming to the UL standards, it is required to keep the temperature of the motor case at 75°C or less, since the motor is recognized as thermal class A.)

# PS Geared Type Frame Size 90 mm

## Specifications



| Motor Product Name                 | Single Shaft                               | AZM98AC-PS5                                      | AZM98AC-PS7.2 | AZM98AC-PS10 | AZM98AC-PS25  | AZM98AC-PS36 | AZM98AC-PS50  |    |
|------------------------------------|--|--|---------------|--------------|---------------|--------------|---------------|----|
|                                    | With Electromagnetic Brake                 | AZM98MC-PS5                                      | AZM98MC-PS7.2 | AZM98MC-PS10 | AZM98MC-PS25  | AZM98MC-PS36 | AZM98MC-PS50  |    |
| Driver Product Name                | Built-in Controller Type                   | AZD-CD (Single-Phase 200-240 VAC)                |               |              |               |              |               |    |
|                                    | Pulse-Input Type with RS-485 Communication | AZD-CX (Single-Phase 200-240 VAC)                |               |              |               |              |               |    |
|                                    | Pulse Input Type                           | AZD-C (Single-Phase 200-240 VAC)                 |               |              |               |              |               |    |
| Maximum Holding Torque             | N·m  | 10   | 14            | 20           | 37            |              |               |    |
| Rotor Inertia                      | J: kg·m <sup>2</sup>                       | 1090×10 <sup>-7</sup> (1250×10 <sup>-7</sup> )*1 |               |              |               |              |               |    |
| Gear Ratio                         |  | 5  | 7.2           | 10           | 25            | 36           | 50            |    |
| Resolution                         | Resolution Setting: 1000 P/R               | 0.072°/Pulse                                     | 0.05°/Pulse   | 0.036°/Pulse | 0.0144°/Pulse | 0.01°/Pulse  | 0.0072°/Pulse |    |
| Permissible Torque*                | N·m  | *  | *             | 20           | 37            |              |               |    |
| Maximum Instantaneous Torque*      | N·m  | *  | *             | *            | 60            |              |               |    |
| Holding Torque at Motor Standstill | Power ON                                   | N·m  | 5             | 7.2          | 10            | 25           | 36            | 37 |
|                                    | With Electromagnetic Brake                 | N·m  | 5             | 7.2          | 10            | 25           | 36            | 37 |
| Speed Range                        | r/min                                      | 0~600  | 0~416         | 0~300        | 0~120         | 0~83         | 0~60          |    |
| Backlash                           | arcmin                                     | 7 (0.12)   |               |              |               | 9 (0.15)     |               |    |
| Power Supply Input                 | Voltage and Frequency                      | Single-Phase 200-240 VAC -15~+6% 50/60 Hz        |               |              |               |              |               |    |
|                                    | Input Current                              | A 3.3  |               |              |               |              |               |    |
| Control Power Supply               |  | 24 VDC ±5%*2 0.25 A (0.5 A)*1                    |               |              |               |              |               |    |

\* For the geared motor output torque, refer to the speed – torque characteristics.

\*1 The brackets ( ) indicate the specifications for the product with an electromagnetic brake.

\*2 For the type with an electromagnetic brake, a 24 VDC±4% specification applies if the wiring distance between the motor and driver is extended to 20 m using a cable.

## Speed - Torque Characteristics (Reference Value)

**AZ98 Gear Ratio 5**

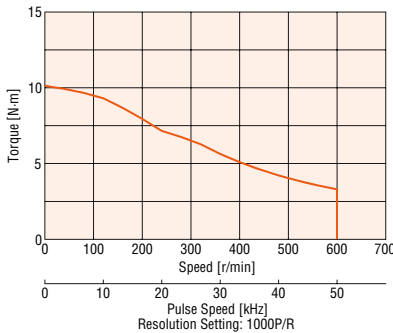

**AZ98 Gear Ratio 7.2**

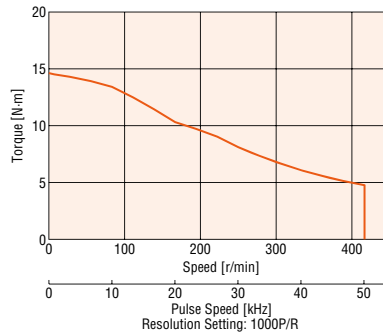

**AZ98 Gear Ratio 10**

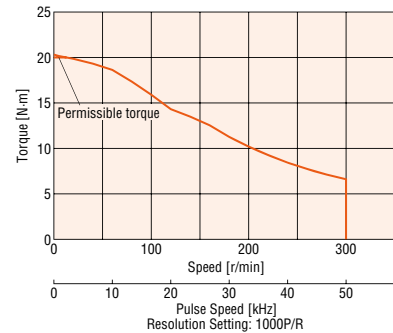

**AZ98 Gear Ratio 25**

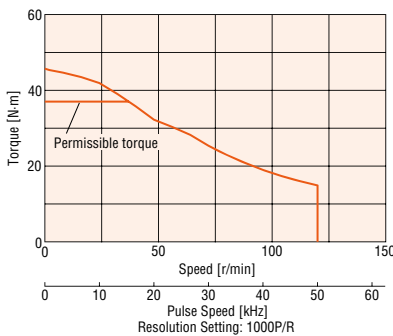

**AZ98 Gear Ratio 36**

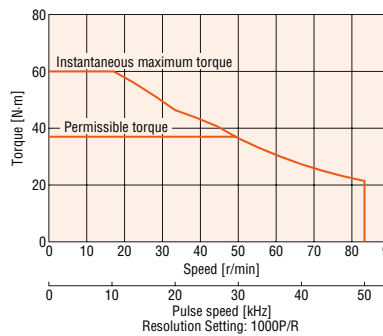

**AZ98 Gear Ratio 50**

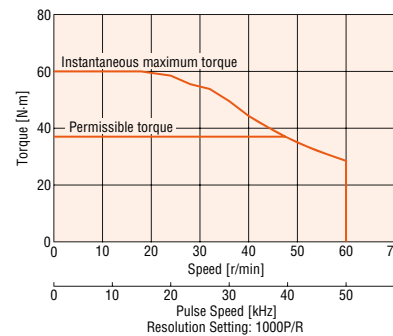

### Notes

- The speed-torque characteristics are data based upon our measurement conditions. When these conditions change, these characteristics may change.
- Depending on the driving conditions, a considerable amount of heat may be generated by the motor. Be sure to keep the motor case temperature at 80°C or less in order to protect the ABZO sensor. (When conforming to the UL standards, it is required to keep the temperature of the motor case at 75°C or less, since the motor is recognized as thermal class A.)

# HPG Geared Type Frame Size 40 mm, 60 mm, 90 mm



## Specifications

|   |  |   |   |  |   |  |   |  |
|---|--|---|---|--|---|--|---|--|
| Motor Product Name                          | Single Shaft                               | <b>AZM46AC-HP5</b> □                            | <b>AZM46AC-HP9</b> □                            | <b>AZM66AC-HP5</b> □                           | <b>AZM66AC-HP15</b> □                         | <b>AZM98AC-HP5</b> □                             | <b>AZM98AC-HP15</b> □                           |  |
|   | With Electromagnetic Brake                 | <b>AZM46MC-HP5</b> □                            | <b>AZM46MC-HP9</b> □                            | <b>AZM66MC-HP5</b> □                           | <b>AZM66MC-HP15</b> □                         | <b>AZM98MC-HP5</b> □                             | <b>AZM98MC-HP15</b> □                           |  |
| Driver Product Name                         | Built-in Controller Type                   | <b>AZD-CD</b> (Single-Phase 200-240 VAC)        |   |  |   |  |   |  |
|   | Pulse-Input Type with RS-485 Communication | <b>AZD-CX</b> (Single-Phase 200-240 VAC)        |   |  |   |  |   |  |
|   | Pulse Input Type                           | <b>AZD-C</b> (Single-Phase 200-240 VAC)         |   |  |   |  |   |  |
| Maximum Holding Torque                      | N·m  | 1.5   | 2.5   | 5.9  | 9   | 10   | 24  |  |
| Rotor Inertia                               | J: kg·m <sup>2</sup>                       | 55×10 <sup>-7</sup> (71×10 <sup>-7</sup> )*1    |   | 370×10 <sup>-7</sup> (530×10 <sup>-7</sup> )*1 |   | 1090×10 <sup>-7</sup> (1250×10 <sup>-7</sup> )*1 |   |  |
| Inertia*2                                   | J: kg·m <sup>2</sup>                       | 5.8×10 <sup>-7</sup><br>(4.2×10 <sup>-7</sup> ) | 3.4×10 <sup>-7</sup><br>(2.9×10 <sup>-7</sup> ) | 92×10 <sup>-7</sup><br>(86×10 <sup>-7</sup> )  | 78×10 <sup>-7</sup><br>(77×10 <sup>-7</sup> ) | 629×10 <sup>-7</sup><br>(589×10 <sup>-7</sup> )  | 488×10 <sup>-7</sup><br>(488×10 <sup>-7</sup> ) |  |
| Gear Ratio                                  |  | 5   | 9   | 5  | 15  | 5  | 15  |  |
| Resolution                                  | Resolution Setting: 1000P/R                | 0.072°/Pulse                                    | 0.04°/Pulse                                     | 0.072°/Pulse                                   | 0.024°/Pulse                                  | 0.072°/Pulse                                     | 0.024°/Pulse                                    |  |
| Permissible Torque*                         | N·m  | *   | 2.5   | 5.9  | 9   | *  | 24  |  |
| Maximum Instantaneous Torque*               | N·m  | *   | *   | *  | *   | *  | *   |  |
| Holding Torque at Power ON                  | N·m  | 0.75  | 1.35  | 3  | 9   | 5  | 15  |  |
| Motor Standstill With Electromagnetic Brake | N·m  | 0.75  | 1.35  | 3  | 9   | 5  | 15  |  |
| Speed Range                                 | r/min                                      | 0~900   | 0~500   | 0~900  | 0~300   | 0~900  | 0~300   |  |
| Backlash                                    | arcmin                                     | 3 (0.05°)                                       |   |  |   |  |   |  |
| Power Supply Input                          | Voltage and Frequency                      | Single-Phase 200-240 VAC -15~+6% 50/60 Hz       |   |  |   |  |   |  |
|   | Input Current                              | A   | 1.7   |  | 2.3   |  | 3.3   |  |
| Control Power Supply                        |  | 24 VDC ±5%*4 0.25 A (0.33 A)*1                  |   | 24 VDC ±5%*4 0.25 A (0.5 A)*1                  |   |  |   |  |
| Output Flange Surface Runout*3              | mm   |   |   |  | 0.02  |  |   |  |
| Output Flange Inner Runout*3                | mm   | 0.03  |   |  | 0.04  |  |   |  |

\* For the geared motor output torque, refer to the speed – torque characteristics.

● For the flange output type, **F** is specified where the box □ is located in the product name.

\*1 The brackets ( ) indicate the specifications for the product with an electromagnetic brake.

\*2 The internal inertia of the gear is the value converted to the motor shaft. ( ) contain values for the flange output type.

\*3 Specifications for the flange output type.

\*4 For the type with an electromagnetic brake, a 24 VDC±4% specification applies if the wiring distance between the motor and driver is extended to 20 m using a cable.

## Speed - Torque Characteristics (Reference Value)

**AZ46 Gear Ratio 5**

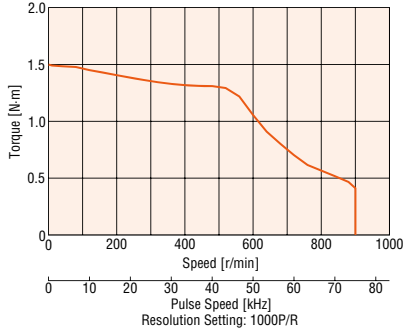

**AZ66 Gear Ratio 5**

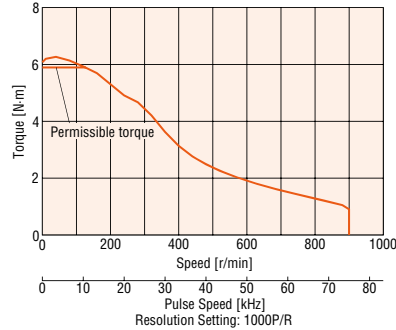

**AZ98 Gear Ratio 5**

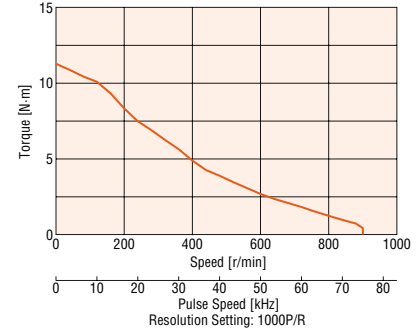

**AZ46 Gear Ratio 9**

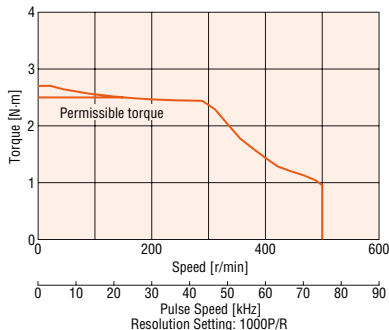

**AZ66 Gear Ratio 15**

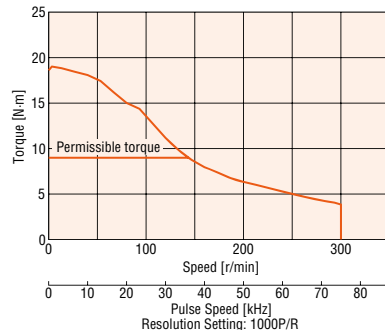

**AZ98 Gear Ratio 15**

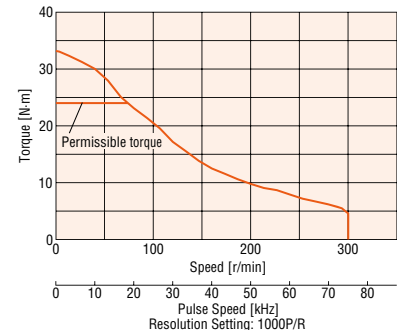

### Notes

● The speed-torque characteristics are data based upon our measurement conditions. When these conditions change, these characteristics may change.

● Depending on the driving conditions, a considerable amount of heat may be generated by the motor. Be sure to keep the motor case temperature at 80°C or less in order to protect the ABZO sensor. (When conforming to the UL standards, it is required to keep the temperature of the motor case at 75°C or less, since the motor is recognized as thermal class A.)

# Harmonic Geared Type Frame Size 42 mm, 60 mm, 90 mm

## Specifications



| Motor Product Name                 | Single Shaft                               | AZM46AC-HS50                                 | AZM46AC-HS100 | AZM66AC-HS50                                   | AZM66AC-HS100 | AZM98AC-HS50                                     | AZM98AC-HS100 |    |
|------------------------------------|--|--|---------------|--|---------------|--|---------------|----|
|                                    | With Electromagnetic Brake                 | AZM46MC-HS50                                 | AZM46MC-HS100 | AZM66MC-HS50                                   | AZM66MC-HS100 | AZM98MC-HS50                                     | AZM98MC-HS100 |    |
| Driver Product Name                | Built-in Controller Type                   | AZD-CD (Single-Phase 200-240 VAC)            |               |  |               |  |               |    |
|                                    | Pulse Input Type with RS-485 Communication | AZD-CX (Single-Phase 200-240 VAC)            |               |  |               |  |               |    |
|                                    | Pulse Input Type                           | AZD-C (Single-Phase 200-240 VAC)             |               |  |               |  |               |    |
| Maximum Holding Torque             | N·m  | 3.5  | 5             | 7  | 10            | 33   | 52            |    |
| Rotor Inertia                      | J: kg·m <sup>2</sup>                       | 72×10 <sup>-7</sup> (88×10 <sup>-7</sup> )*1 |               | 405×10 <sup>-7</sup> (565×10 <sup>-7</sup> )*1 |               | 1290×10 <sup>-7</sup> (1450×10 <sup>-7</sup> )*1 |               |    |
| Gear Ratio                         |  | 50   | 100           | 50   | 100           | 50   | 100           |    |
| Resolution                         | Resolution Setting: 1000P/R                | 0.0072°/Pulse                                | 0.0036°/Pulse | 0.0072°/Pulse                                  | 0.0036°/Pulse | 0.0072°/Pulse                                    | 0.0036°/Pulse |    |
| Permissible Torque                 | N·m  | 3.5  | 5             | 7  | 10            | 33   | 52            |    |
| Maximum Instantaneous Torque*      | N·m  | 8.3  | 11            | 23   | 36            | *  | 107           |    |
| Holding Torque at Motor Standstill | Power ON                                   | N·m  | 3.5           | 5  | 7             | 10   | 33            | 52 |
|                                    | With Electromagnetic Brake                 | N·m  | 3.5           | 5  | 7             | 10   | 33            | 52 |
| Speed Range                        | r/min                                      | 0~70   | 0~35          | 0~70   | 0~35          | 0~70   | 0~35          |    |
| Lost Motion (Load Torque)          |  | arcmin                                       | 1.5 max.      | 1.5 max.                                       | 0.7 max.      | 0.7 max.   | 0.7 max.      |    |
|                                    |  |  | (±0.16 N·m)   | (±0.20 N·m)                                    | (±0.28 N·m)   | (±0.39 N·m)                                      | (±1.2 N·m)    |    |
| Power Supply Input                 | Voltage and Frequency                      | Single-Phase 200-240 VAC -15~+6% 50/60 Hz    |               |  |               |  |               |    |
|                                    | Input Current                              | A  | 1.7           |  | 2.3           |  | 3.3           |    |
| Control Power Supply               |  | 24 VDC ±5%*2 0.25 A (0.33 A)*1               |               | 24 VDC ±5%*2 0.25 A (0.5 A)*1                  |               |  |               |    |

\* For the geared motor output torque, refer to the speed – torque characteristics.

\*1 The brackets ( ) indicate the specifications for the product with an electromagnetic brake.

\*2 For the type with an electromagnetic brake, a 24 VDC±4% specification applies if the wiring distance between the motor and driver is extended to 20 m using a cable.

### Note

● The rotor inertia represents a sum of the inertia of the harmonic gear converted to motor shaft values.

## Speed - Torque Characteristics (Reference Value)

**AZ46 Gear Ratio 50**

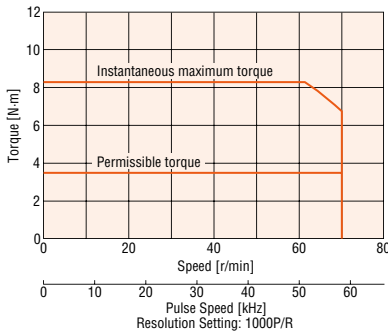

**AZ66 Gear Ratio 50**

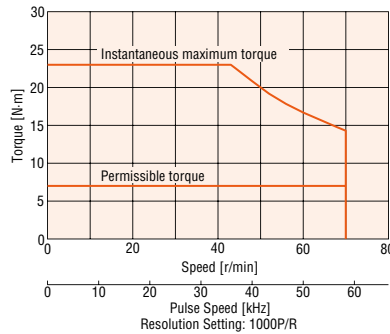

**AZ98 Gear Ratio 50**

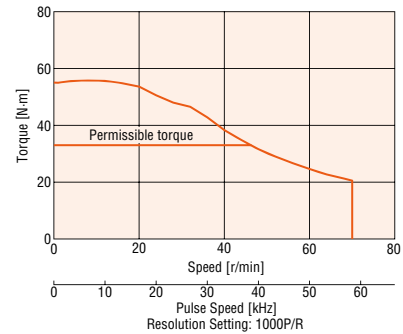

**AZ46 Gear Ratio 100**

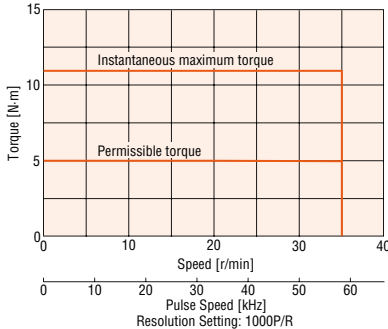

**AZ66 Gear Ratio 100**

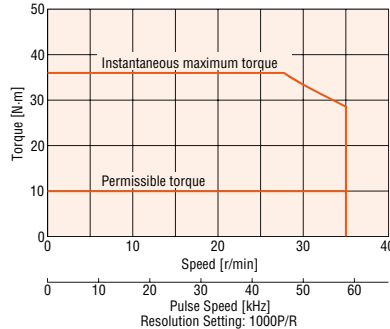

**AZ98 Gear Ratio 100**

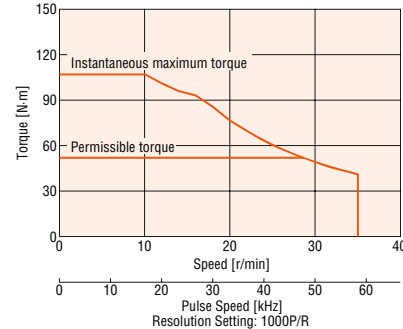

### Notes

● The speed-torque characteristics are data based upon our measurement conditions. When these conditions change, these characteristics may change.

● Depending on the driving conditions, a considerable amount of heat may be generated by the motor. Be sure to keep the motor case temperature at 80°C or less in order to protect the ABZO sensor. (When conforming to the UL standards, it is required to keep the temperature of the motor case at 75°C or less, since the motor is recognized as thermal class A.)

## Driver Specifications

| Driver Type                                     | Built-in Controller Type             | Pulse-Input Type with RS-485 Communication        | Pulse Input Type  |     |     |
|---|--------------------------------------|---|---|-----|-----|
| Driver Product Name                             | <b>AZD-CD</b>                        | <b>AZD-CX</b>                                     | <b>AZD-C</b>  |     |     |
| I/O Function                                    | Maximum Input Pulse Frequency        | –   | Line driver output by programmable controller: 1 MHz (When the pulse duty is 50 %)<br>Open-collector output by programmable controller: 250 kHz (When the pulse duty is 50 %)<br>Negative Logic Pulse Input (Initial Value) |     |     |
|   | Number of Positioning Data Sets      | 256 Points  | 256 Points*1  |     |     |
|   | Direct Input                         | 10 Points   | 6 Points  |     |     |
|   | Direct Output                        | 6 Points  |   |     |     |
|   | RS-485 Communication Network Input   | 16 Points   | –   |     |     |
|   | RS-485 Communication Network Output  | 16 Points   | –   |     |     |
| Setting Tool                                    | Data Setting Software <b>MEXEO2</b>  | ○   |   |     |     |
| Coordinates Management Method                   |                                      | Battery-free Absolute System                      |   |     |     |
| Operation                                       | Positioning Operation Method         | Positioning Operation                             | ○   | ○   | ○*1 |
|   |                                      | Positioning Push-Motion Operation*2               | ○   | ○   | ○*1 |
|   | Positioning Operation Method         | Independent Operation                             | ○   | ○   | ○*1 |
|   |                                      | Sequential Operation                              | ○   | ○   | ○*1 |
|   |                                      | Multistep Speed-Change (Configuration Connection) | ○   | ○   | ○*1 |
|   | Sequence Control                     | Loop Operation (Repeating)                        | ○   | ○   | ○*1 |
|   |                                      | Event Jump Operation                              | ○   | ○   | ○*1 |
|   | Continuous Operation                 | Position Control                                  | ○   | ○   | ○*1 |
|   |                                      | Speed Control                                     | ○   | ○   | ○*1 |
|   |                                      | Torque Control                                    | ○   | ○   | ○*1 |
| Pushing   |                                      | ○   | ○   | ○*1 |     |
| Return-to-home Operation                        | Return-to-home Operation             | ○   | ○   | ○   |     |
|   | High Speed Return-to-Home Operation  | ○   | ○   | ○   |     |
| JOG Operation                                   |                                      | ○   | ○   | ○   |     |
| Monitor/Information                             | Waveform Monitoring                  | ○   | ○   | ○   |     |
|   | Overload Detection                   | ○   | ○   | ○   |     |
|   | Overheat Detection (Motor/Driver)    | ○   | ○   | ○   |     |
|   | Position/Speed Information           | ○   | ○   | ○   |     |
|   | Temperature Detection (Motor/Driver) | ○   | ○   | ○   |     |
|   | Motor Load Factor                    | ○   | ○   | ○   |     |
| Distance Traveled/Integrating Distance Traveled | ○                                    | ○   | ○   |     |     |
| Alarm   |                                      | ○   | ○   | ○   |     |

\*1 This can be used by setting with the data setting software **MEXEO2**

## Built-in Controller Type RS-485 Communication Specification

|                            |  |
|----------------------------|--|
| Protocol                   | Modbus RTU Mode  |
| Electrical Characteristics | EIA-485 Based, Straight Cable<br>Use shielded twisted-pair cables (TIA/EIA-568B CAT5e or better recommended). The max. total extension length is 50 m. |
| Communication Mode         | Half duplex and start-stop synchronization (data: 8 bits, stop bit: 1 bit or 2 bits, parity: none, even, or odd)                                       |
| Baud Rate                  | 9600 bps/19200 bps/38400 bps/57600 bps/115200 bps/230400 bps are available   |
| Connection Type            | Up to 31 units can be connected to a single programmable controller (master equipment).  |



## General Specifications

|   | Motor   | Driver  |                  |
|---|---|---|------------------|
|   |   | Built-in Controller Type<br>Pulse-Input Type with RS-485 Communication  | Pulse Input Type |
| Heat-resistant Class                                  | 130 (B)<br>[UL 105 (A) certified]   | -   |                  |
| Insulation Resistance                                 | 100 MΩ or more when a 500 VDC megger is applied between the following places:<br>· Case – Motor Windings<br>· Case – Electromagnetic Brake Windings*1                         | 100 MΩ or more when a 500 VDC megger is applied between the following places:<br>· Protective Earth Terminal – Power Supply Terminal<br>· Encoder Connector – Power Supply Terminal<br>· I/O Signal Terminal – Power Supply Terminal  |                  |
| Dielectric Voltage                                    | Sufficient to withstand the following for 1 minute:<br>· Case – Motor Windings 1.5 kVAC, 50 Hz or 60 Hz<br>· Case – Electromagnetic Brake Windings*1 1.5 kVAC, 50 Hz or 60 Hz | Sufficient to withstand the following for 1 minute:<br>· Protective Earth Terminal – Power Supply Terminal 1.5 kVAC, 50 Hz or 60 Hz<br>· Encoder Connector – Power Supply Terminal 1.8 kVAC, 50 Hz or 60 Hz<br>· I/O Signal Terminal – Power Supply Terminal 1.8 kVAC, 50 Hz or 60 Hz |                  |
| Operating Environment<br>(In operation)               | Ambient Temperature   | 0~+40°C (Non-freezing) *2   |                  |
|   | Ambient Humidity  | 85% or less (Non-condensing)  |                  |
|   | Atmosphere  | No corrosive gases or dust. The product should not be exposed to water, oil or other liquids.   |                  |
| Degree of Protection                                  | IP66 (excluding installation surfaces and connector locations)  | IP10  | IP20             |
| Stop Position Accuracy                                | <b>AZM46, AZM48</b> : ±4 Minutes (±0.067°)  | <b>AZM66, AZM69, AZM98, AZM911</b> : ±3 Minutes (±0.05°)  |                  |
| Shaft Runout  | 0.05 T.I.R. (mm)*4  | -   |                  |
| Concentricity of Installation Pilot to the Shaft      | 0.075 T.I.R. (mm)*4   | -   |                  |
| Perpendicularity of Installation Surface to the Shaft | 0.075 T.I.R. (mm)*4   | -   |                  |
| Multiple Rotation Detection Range Upon Power OFF      | ±900 Rotation (1,800 Rotations)   |   |                  |

\*1 Only for products with an electromagnetic brake.

\*2 Based on Oriental Motor's measurement conditions.

\*3 When a heat sink of a capacity at least equivalent to an aluminum plate with a size of 200×200 mm and 2 mm thickness.

\*4 T. I. R. (Total Indicator Reading): The total dial gauge reading when the measurement section is rotated once around the reference axis center.

### Note

- Do not measure insulation resistance or perform a dielectric strength test while the motor and driver are connected.  
Also, do not perform these tests on the motor absolute sensor part.

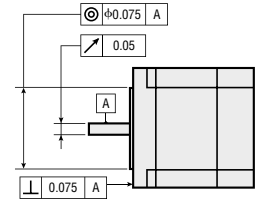

## Electromagnetic Brake Specifications

| Product Name          | AZM46                    | AZM66 | AZM69 | AZM98 |
|-----------------------|--------------------------|-------|-------|-------|
| Type                  | Power Off Activated Type |       |       |       |
| Power Supply Voltage  | 24 VDC ±5%*              |       |       |       |
| Power Supply Current  | A                        | 0.08  | 0.25  | 0.25  |
| Brake Activation Time | ms                       | 20    |       |       |
| Brake Release Time    | ms                       | 30    |       |       |
| Time Rating           | Continuous               |       |       |       |

\*If a 20 m extension cable is used for the electromagnetic brake type, the 24 VDC±4% specification applies.

- The product names are listed such that the product names are distinguishable.

## Rotation Direction

This refers to the direction viewed from the output shaft side.

The rotation direction of the gear output shaft with respect to the standard type motor output shaft differs depending on the type of gear and gear ratio.

Refer to the following table.

| Type   | Gear Ratio          | Rotation Direction with Respect to Motor Output Shaft |
|--|---------------------|---|
| <b>TS</b> Geared Type  | <b>3.6, 7.2, 10</b> | Same direction  |
|  | <b>20, 30</b>       | Opposite direction                                    |
| <b>FC</b> Geared Type<br><b>PS</b> Geared Type<br><b>HPG</b> Geared Type | All gear ratios     | Same direction  |
| Harmonic Geared Type   | All gear ratios     | Opposite direction                                    |

### Standard Type Motor

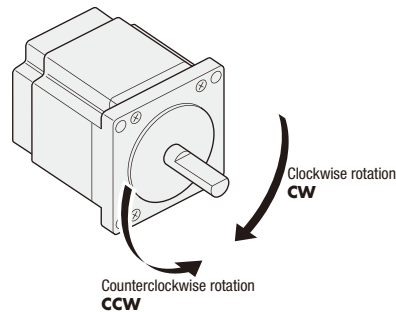

# Permissible Radial Load and Permissible Axial Load

Unit: N

| Type                 | Motor Frame Size | Product              | Gear Ratio             | Permissible Radial Load    |      |      |      |      | Permissible Axial Load |
|----------------------|------------------|----------------------|------------------------|----------------------------|------|------|------|------|------------------------|
|                      |                  |                      |                        | Distance from Shaft End mm |      |      |      |      |                        |
|                      |                  |                      |                        | 0                          | 5    | 10   | 15   | 20   |                        |
| Standard Type        | 42 mm            | <b>AZM46</b>         | -                      | 35                         | 44   | 58   | 85   | -    | 15                     |
|                      |                  | <b>AZM48</b>         |                        | 30                         | 35   | 44   | 58   | 85   |                        |
|                      | 60 mm            | <b>AZM66, AZM69</b>  |                        | 90                         | 100  | 130  | 180  | 270  | 30                     |
|                      | 85 mm            | <b>AZM98, AZM911</b> |                        | 260                        | 290  | 340  | 390  | 480  | 60                     |
| TS Geared Type       | 42 mm            | <b>AZM46</b>         | <b>3.6, 7.2, 10</b>    | 20                         | 30   | 40   | 50   | -    | 15                     |
|                      |                  |                      | <b>20, 30</b>          | 40                         | 50   | 60   | 70   | -    |                        |
|                      | 60 mm            | <b>AZM66</b>         | <b>3.6, 7.2, 10</b>    | 120                        | 135  | 150  | 165  | 180  | 40                     |
|                      |                  |                      | <b>20, 30</b>          | 170                        | 185  | 200  | 215  | 230  |                        |
|                      | 90 mm            | <b>AZM98</b>         | <b>3.6, 7.2, 10</b>    | 300                        | 325  | 350  | 375  | 400  | 150                    |
|                      |                  |                      | <b>20, 30</b>          | 400                        | 450  | 500  | 550  | 600  |                        |
| FC Geared Type       | 42 mm            | <b>AZM46</b>         | <b>7.2, 10, 20, 30</b> | 180                        | 200  | 220  | 250  | -    | 100                    |
|                      | 60 mm            | <b>AZM66</b>         |                        | 270                        | 290  | 310  | 330  | -    | 200                    |
| PS Geared Type       | 42 mm            | <b>AZM46</b>         | <b>5</b>               | 70                         | 80   | 95   | 120  | -    | 100                    |
|                      |                  |                      | <b>7.2</b>             | 80                         | 90   | 110  | 140  | -    |                        |
|                      |                  |                      | <b>10</b>              | 85                         | 100  | 120  | 150  | -    |                        |
|                      |                  |                      | <b>25</b>              | 120                        | 140  | 170  | 210  | -    |                        |
|                      |                  |                      | <b>36</b>              | 130                        | 160  | 190  | 240  | -    |                        |
|                      |                  |                      | <b>50</b>              | 150                        | 170  | 210  | 260  | -    |                        |
|                      | 60 mm            | <b>AZM66</b>         | <b>5</b>               | 170                        | 200  | 230  | 270  | 320  | 200                    |
|                      |                  |                      | <b>7.2</b>             | 200                        | 220  | 260  | 310  | 370  |                        |
|                      |                  |                      | <b>10</b>              | 220                        | 250  | 290  | 350  | 410  |                        |
|                      |                  |                      | <b>25</b>              | 300                        | 340  | 400  | 470  | 560  |                        |
|                      |                  |                      | <b>36</b>              | 340                        | 380  | 450  | 530  | 630  |                        |
|                      |                  |                      | <b>50</b>              | 380                        | 430  | 500  | 600  | 700  |                        |
|                      | 90 mm            | <b>AZM98</b>         | <b>5</b>               | 380                        | 420  | 470  | 540  | 630  | 600                    |
|                      |                  |                      | <b>7.2</b>             | 430                        | 470  | 530  | 610  | 710  |                        |
|                      |                  |                      | <b>10</b>              | 480                        | 530  | 590  | 680  | 790  |                        |
|                      |                  |                      | <b>25</b>              | 650                        | 720  | 810  | 920  | 1070 |                        |
|                      |                  |                      | <b>36</b>              | 730                        | 810  | 910  | 1040 | 1210 |                        |
|                      |                  |                      | <b>50</b>              | 820                        | 910  | 1020 | 1160 | 1350 |                        |
| HPG Geared Type      | 40 mm            | <b>AZM46</b>         | <b>5</b>               | 150                        | 170  | 190  | 230  | 270  | 430                    |
|                      |                  |                      | <b>9</b>               | 180                        | 200  | 230  | 270  | 320  | 510                    |
|                      | 60 mm            | <b>AZM66</b>         | <b>5</b>               | 250                        | 270  | 300  | 330  | 360  | 700                    |
|                      |                  |                      | <b>15</b>              | 360                        | 380  | 420  | 460  | 510  | 980                    |
|                      | 90 mm            | <b>AZM98</b>         | <b>5</b>               | 600                        | 630  | 670  | 710  | 750  | 1460                   |
|                      |                  |                      | <b>15</b>              | 830                        | 880  | 930  | 980  | 1050 | 2030                   |
| Harmonic Geared Type | 42 mm            | <b>AZM46</b>         | <b>50, 100</b>         | 180                        | 220  | 270  | 360  | 510  | 220                    |
|                      | 60 mm            | <b>AZM66</b>         |                        | 320                        | 370  | 440  | 550  | 720  | 450                    |
|                      | 90 mm            | <b>AZM98</b>         |                        | 1090                       | 1150 | 1230 | 1310 | 1410 | 1300                   |

- The products can be identified with the detailed product code.
- **PS** geared type, **HPG** geared type, when either the permissible radial load or permissible axial load are added, shall have a lifespan value satisfying 20,000 hours. For **TS** and Harmonic geared types lifespan please contact the nearest Oriental Motor sales office.

## Radial Load and Axial Load

Distance from Shaft End [mm]

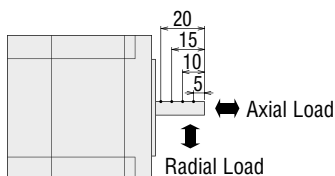

## Permissible Moment Load

If an excentric load is applied when attaching an arm or table to the flange face, calculate the moment load with the following formula. The moment load should not exceed the permissible values shown in the table below.

### HPG Geared Type Flange Output Type

| Product Name | Gear Ratio | Permissible Axial Load (N) | Permissible Moment Load (N·m) | Coefficient a (m) |
|--------------|------------|----------------------------|-------------------------------|-------------------|
| <b>AZM46</b> | <b>5</b>   | 430                        | 4.9                           | 0.006             |
|              | <b>9</b>   | 510                        | 5.9                           |                   |
| <b>AZM66</b> | <b>5</b>   | 700                        | 12.0                          | 0.011             |
|              | <b>15</b>  | 980                        | 17.2                          |                   |
| <b>AZM98</b> | <b>5</b>   | 1460                       | 38.7                          | 0.0115            |
|              | <b>15</b>  | 2030                       | 53.5                          |                   |

m : Work mass (kg)  
 g : Gravitational acceleration (m/s<sup>2</sup>)  
 F : External force (N)  
 L : Distance from center of output flange  
 a : Coefficient (m)  
 ΔF : Load on output flange side (N)  
 F<sub>s</sub> : Permissible axial load (N)  
 ΔM : Moment load (N·m)  
 M : Permissible moment load (N·m)

The required moment load can be calculated according to the following formula.

**Example 1: When external force F (N) is applied at a distance of L (m) from the centre of the output flange**

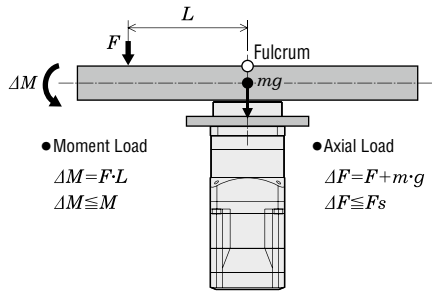

**Example 2: When external force F (N) is applied at a distance of L (m) from the surface mounting of the output flange**

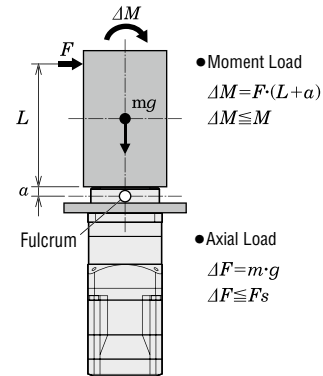

### Harmonic Geared Type

| Product Name | Permissible Axial Load (N) | Permissible Moment Load (N·m) | Coefficient a (m) |
|--------------|----------------------------|-------------------------------|-------------------|
| <b>AZM46</b> | 220                        | 5.6                           | 0.009             |
| <b>AZM66</b> | 450                        | 11.6                          | 0.0114            |

The required moment load can be calculated according to the following formula.

**Example 1: When external force F (N) is applied at a distance of L (m) from the centre of the output flange**

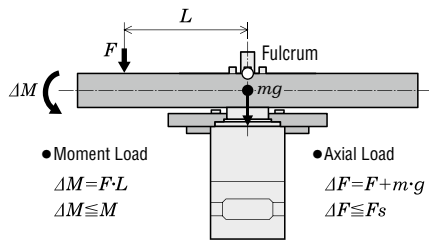

**Example 2: When external force F (N) is applied at a distance of L (m) from the surface mounting of the output flange**

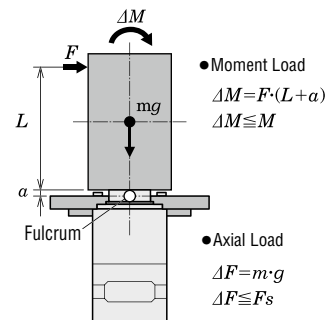

## Load Torque - Driver Input Current Characteristics

The following are the relationships between the load torque and driver input current at each speed when the motor is operated. From these characteristics, it is possible to estimate the current capacity actually required when used with multiple axes. For geared motors, convert to torque and speed at the motor shaft.

$$\text{Motor shaft speed} = \text{Gear output shaft speed} \times \text{Gear ratio [r/min]}$$

$$\text{Motor shaft torque} = \frac{\text{Gear output shaft torque}}{\text{Gear Ratio}} \text{ [N}\cdot\text{m]}$$

### Single-Phase 100-120 VAC

#### AZM46□C

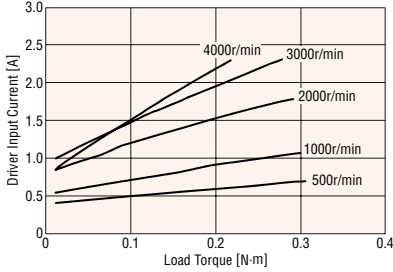

### Single Phase 200-240 VAC

#### AZM46□C

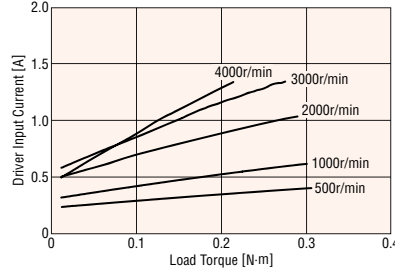

### Three Phase 200-240 VAC

#### AZM46□C

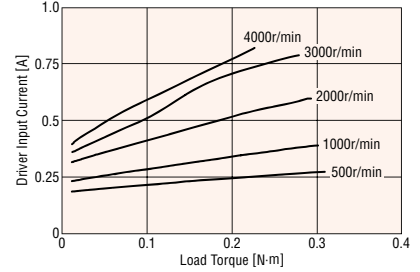

#### AZM48□C

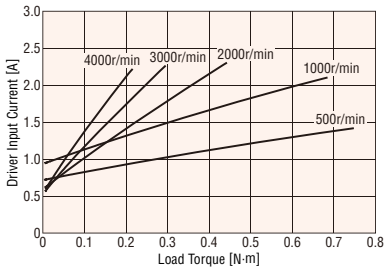

#### AZM48□C

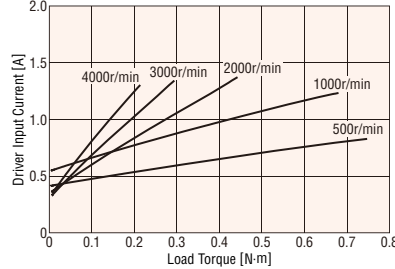

#### AZM48□C

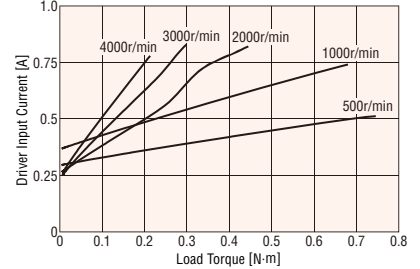

#### AZM66□C

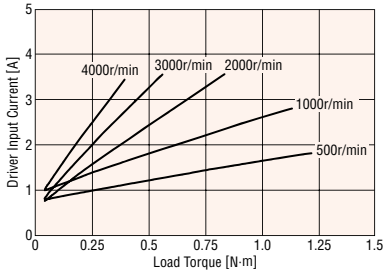

#### AZM66□C

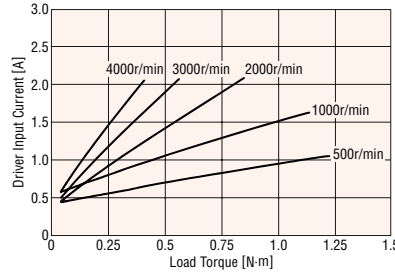

#### AZM66□C

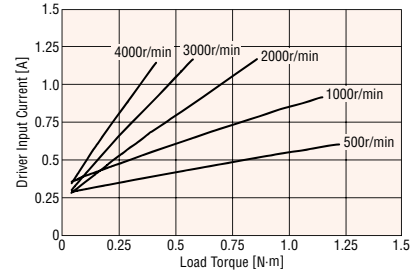

#### AZM69□C

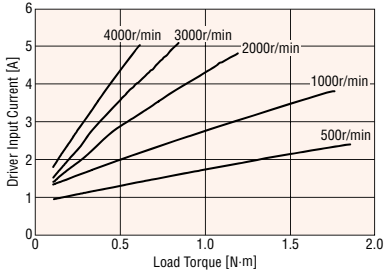

#### AZM69□C

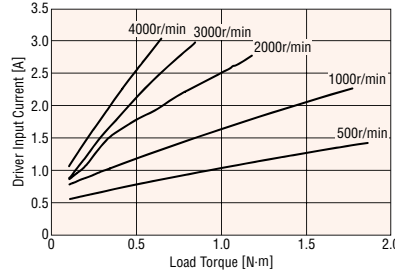

#### AZM69□C

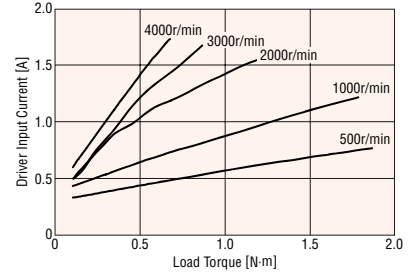

● Single-Phase 100-120 VAC

**AZM98□A**

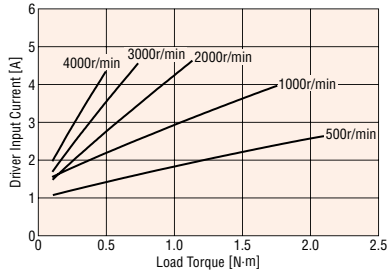

● Single Phase 200-240 VAC

**AZM98□C**

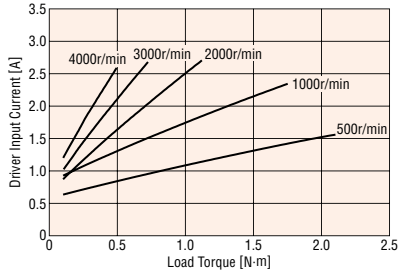

● Three Phase 200-240 VAC

**AZM98□C**

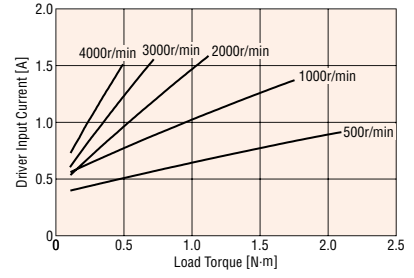

**AZM911□A**

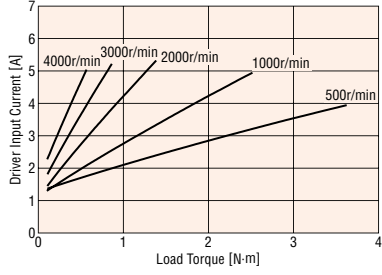

**AZM911□C**

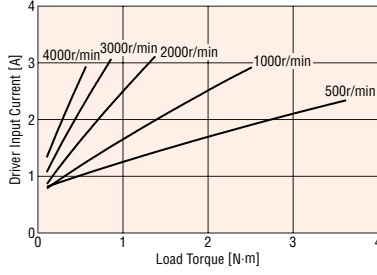

**AZM911□C**

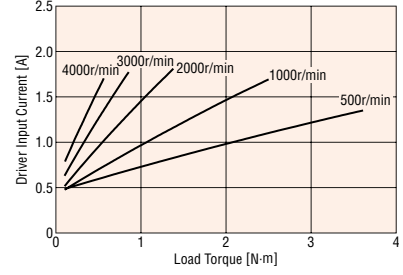

|          |                      |              |                             |            |                          |                      |              |                             |            |                          |                  |             |
|----------|----------------------|--------------|-----------------------------|------------|--------------------------|----------------------|--------------|-----------------------------|------------|--------------------------|------------------|-------------|
| Features | System Configuration | Product Line | Specifications and Features | Dimensions | Connection and Operation | System Configuration | Product Line | Specifications and Features | Dimensions | Connection and Operation | Multiaxis Driver | Accessories |
|          | AC Input             |              |                             |            |                          | DC Input             |              |                             |            |                          |                  |             |

## Dimensions (Unit = mm)

### Motors

#### Standard Type

#### Frame Size 42 mm

| Product Name    | Mass kg |
|-----------------|---------|
| <b>AZM46A□C</b> | 0.44    |

One Side Milled

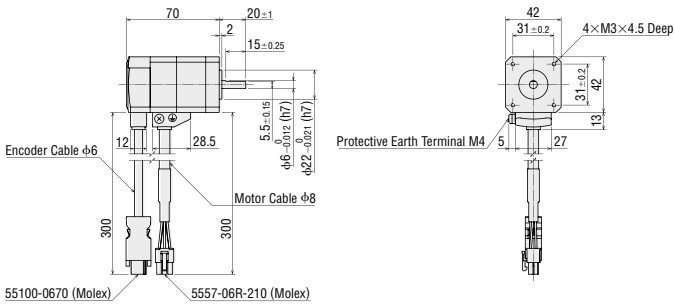

Straight



#### Frame Size 42 mm

| Product Name    | Mass kg |
|-----------------|---------|
| <b>AZM48A□C</b> | 0.68    |

One Side Milled

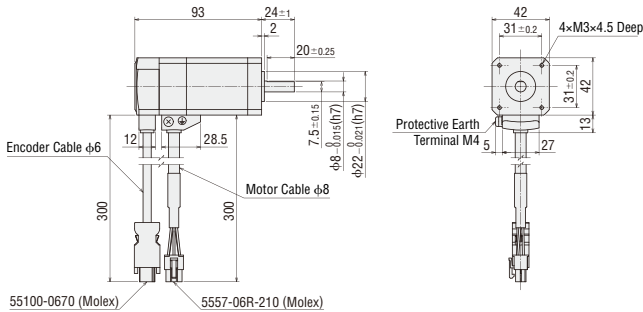

Straight

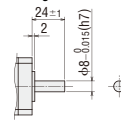

With Key

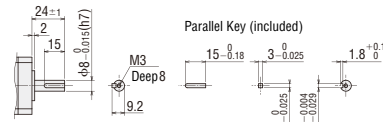

#### Frame Size 60 mm

| Product Name    | L    | Mass kg |
|-----------------|------|---------|
| <b>AZM66A□C</b> | 72   | 0.91    |
| <b>AZM69A□C</b> | 97.5 | 1.4     |

One Side Milled

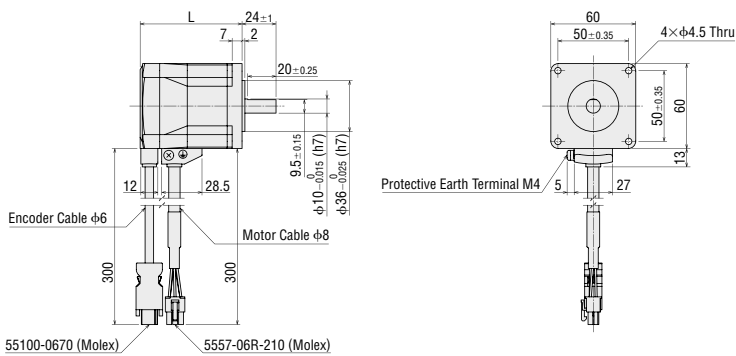

Straight

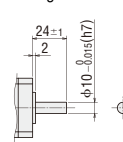

With Key

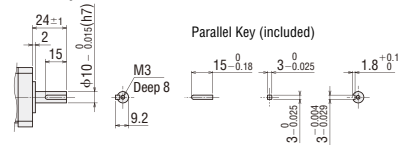

● Either 0 (straight) or 1 (with key) indicating the shaft shape is entered where the box □ is located within the product name. (For AZM46 straight only).

Frame Size 85 mm

| Product Name      | L   | Mass kg |
|-------------------|-----|---------|
| <b>AZM98A</b> □C  | 84  | 1.9     |
| <b>AZM911A</b> □C | 114 | 3       |

One Side Milled

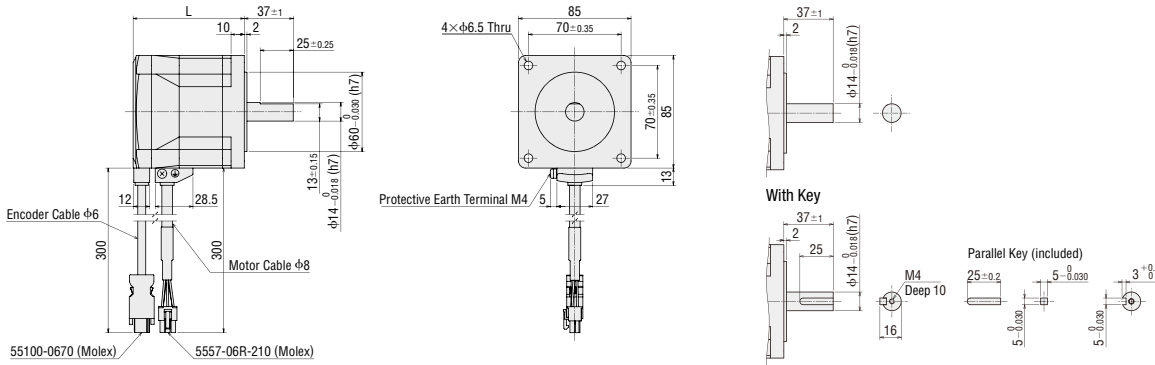

◇ Standard Type with Electromagnetic Brake  
Frame Size 42 mm

| Product Name     | Mass kg |
|------------------|---------|
| <b>AZM46M</b> □C | 0.61    |

One Side Milled

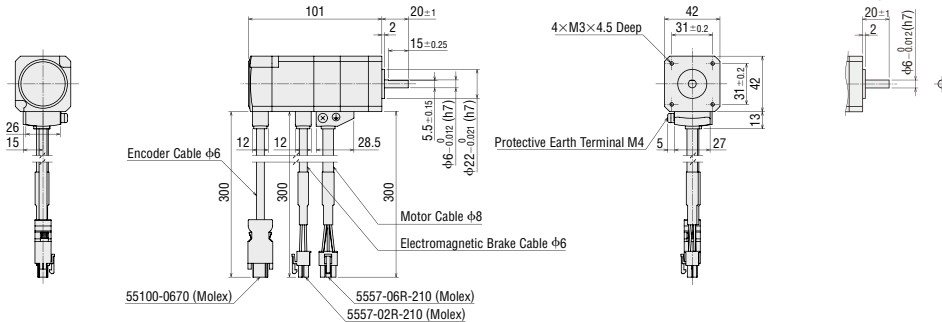

Frame Size 60 mm

| Product Name     | L     | Mass kg |
|------------------|-------|---------|
| <b>AZM66M</b> □C | 118   | 1.3     |
| <b>AZM69M</b> □C | 143.5 | 1.8     |

One Side Milled

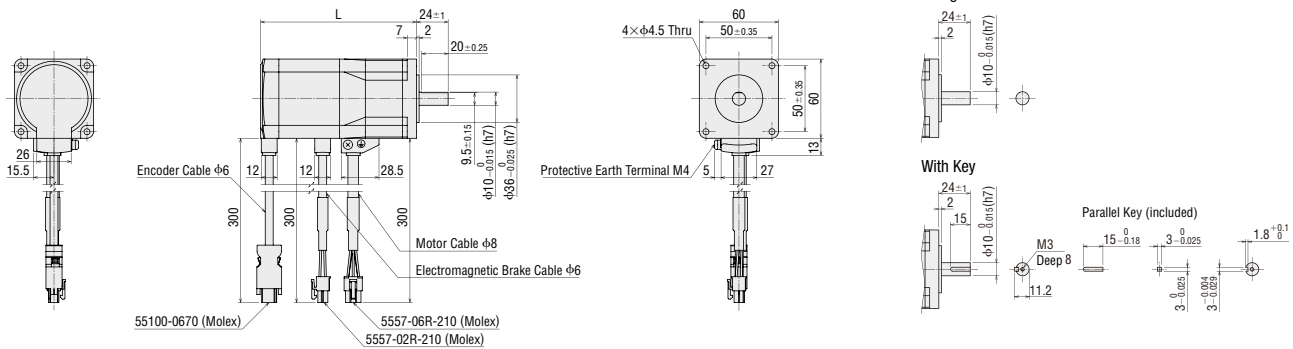

● Either 0 (straight) or 1 (with key) indicating the shaft shape is entered where the box □ is located within the product name. (For AZM46 straight only).

### Frame Size 85 mm

| Product Name     | Mass kg |
|------------------|---------|
| <b>AZM98M</b> □C | 2.5     |

One Side Milled

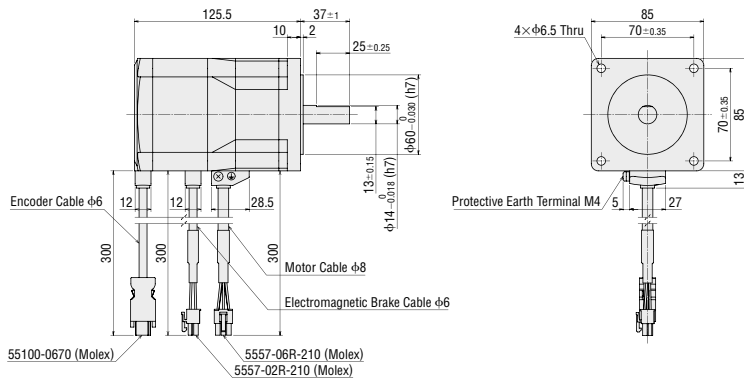

Straight

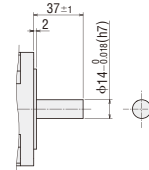

With Key

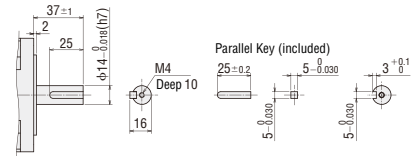

### ◇TS Geared Type

#### Frame Size 42 mm

| Product Name        | Gear Ratio                  | Mass kg |
|---------------------|-----------------------------|---------|
| <b>AZM46AC-TS</b> ◇ | <b>3.6, 7.2, 10, 20, 30</b> | 0.59    |

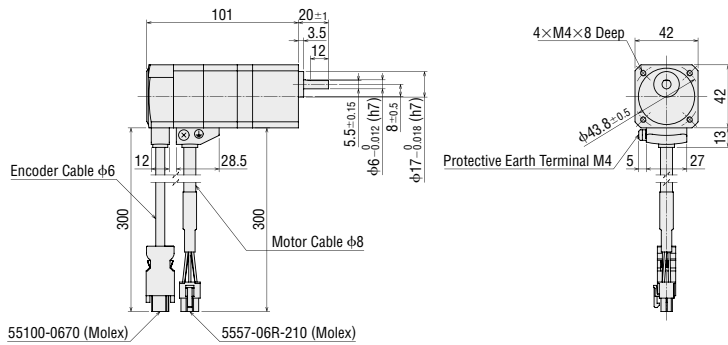

#### ● Cable Direction

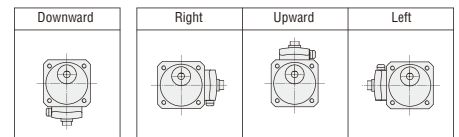

### Frame Size 60 mm

| Product Name        | Gear Ratio                  | Mass kg |
|---------------------|-----------------------------|---------|
| <b>AZM66AC-TS</b> ◇ | <b>3.6, 7.2, 10, 20, 30</b> | 1.3     |

● Installation screw: M4×60 P0.7 (4 screws included)

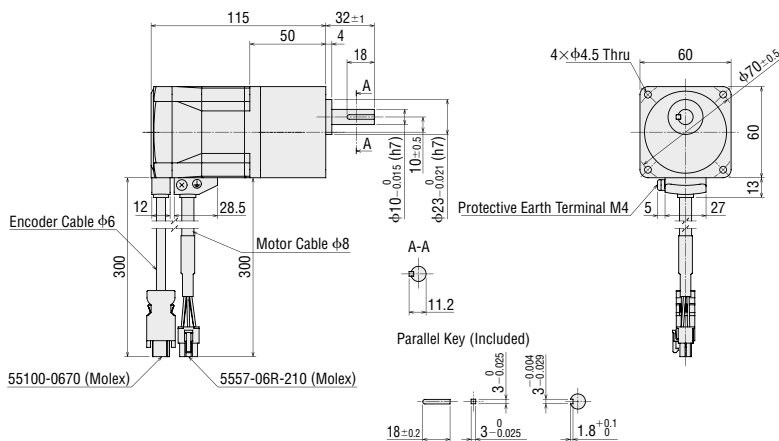

#### ● Cable Direction

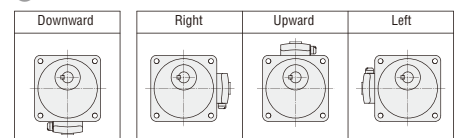

● The ■ within the product name includes a number expressing the gear ratio.

● Either R (right), U (up) or L (left) indicating the cable withdrawing direction is entered where the box ◇ is located within the product name. For downward direction no letter is entered in the box ◇.





### Frame Size 90 mm

| Product Name        | Gear Ratio                  | Mass kg |
|---------------------|-----------------------------|---------|
| <b>AZM98MC-TS</b> ◊ | <b>3.6, 7.2, 10, 20, 30</b> | 3.7     |

● Installation screw: M8×90 P1.25 (4 screws included)

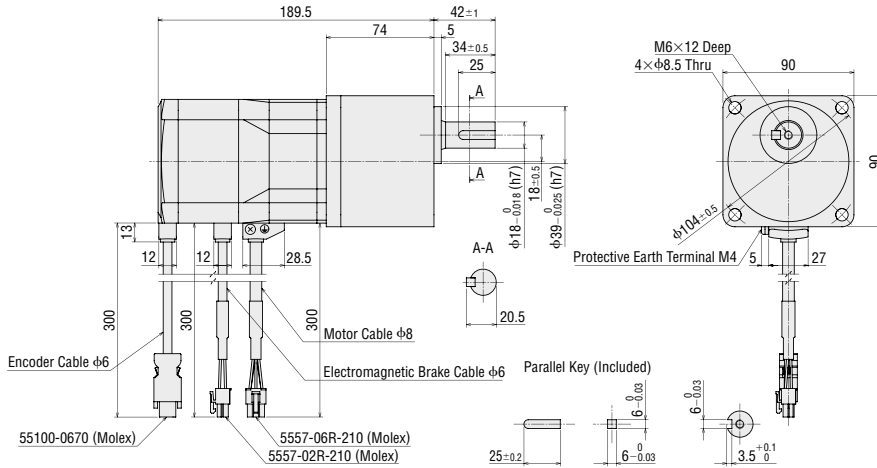

### ● Cable Direction

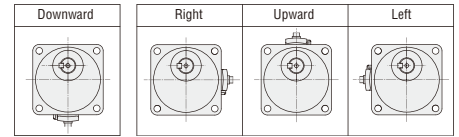

### ◊ FC Geared Type

#### Frame Size 42 mm Cable Withdrawing Direction Up

| Product Name          | Gear Ratio             | Mass kg |
|-----------------------|------------------------|---------|
| <b>AZM46AC-FC</b> ◻UA | <b>7.2, 10, 20, 30</b> | 0.79    |

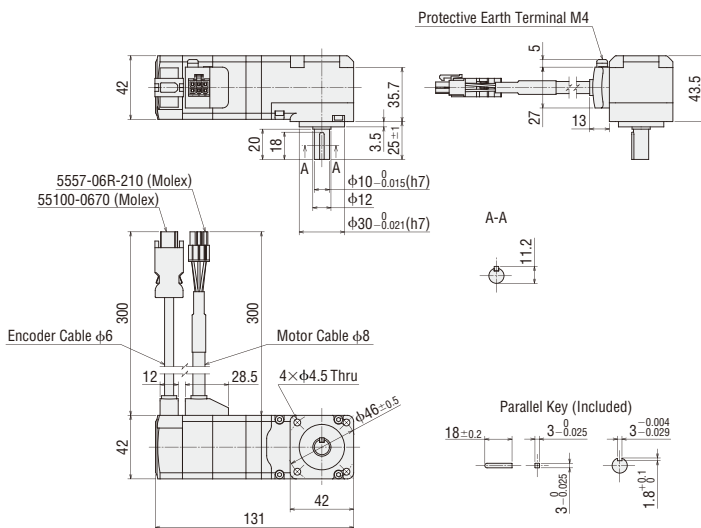

#### Frame Size 42 mm Cable Withdrawing Direction Down

| Product Name          | Gear Ratio             | Mass kg |
|-----------------------|------------------------|---------|
| <b>AZM46AC-FC</b> ◻DA | <b>7.2, 10, 20, 30</b> | 0.79    |

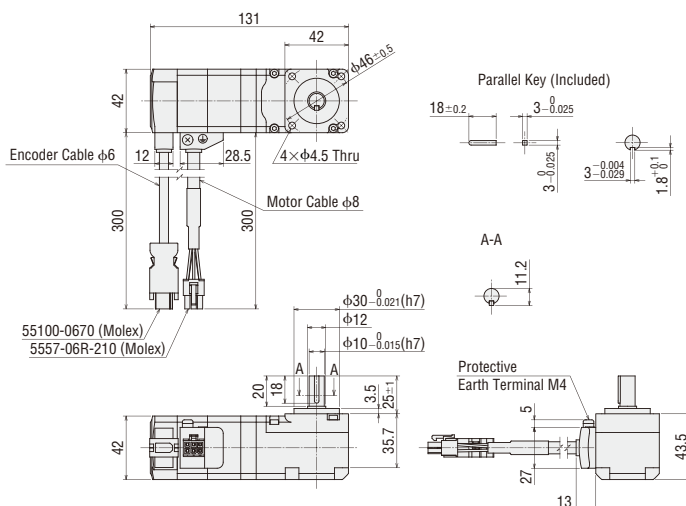

● The ◻ within the product name includes a number expressing the gear ratio.

● Either R (right), U (up) or L (left) indicating the cable withdrawing direction is entered where the box ◊ is located within the product name. For downward direction no letter is entered in the box ◊.

### Frame Size 60 mm Cable Withdrawing Direction Up

| Product Name                  | Gear Ratio             | Mass kg |
|-------------------------------|------------------------|---------|
| <b>AZM66AC-FC</b> ■ <b>UA</b> | <b>7.2, 10, 20, 30</b> | 1.8     |

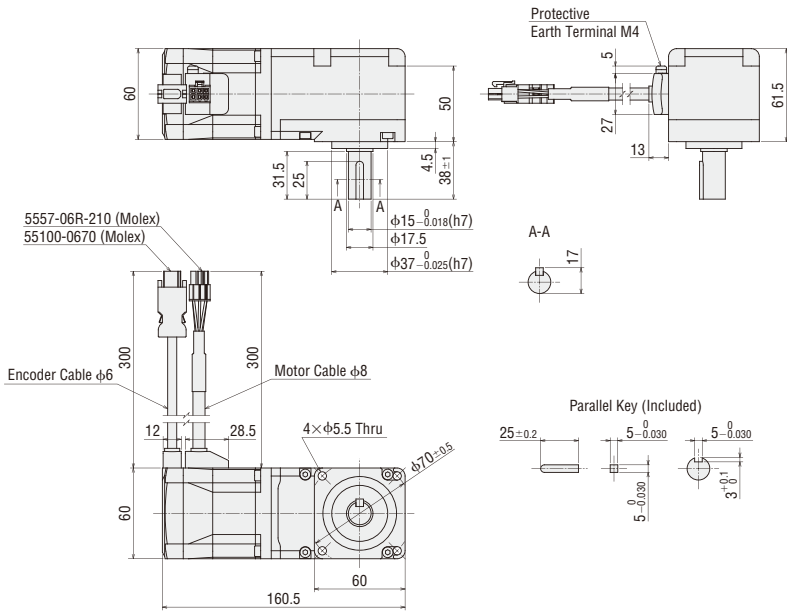

### Frame Size 60 mm Cable Withdrawing Direction Down

| Product Name                  | Gear Ratio             | Mass kg |
|-------------------------------|------------------------|---------|
| <b>AZM66AC-FC</b> ■ <b>DA</b> | <b>7.2, 10, 20, 30</b> | 1.8     |

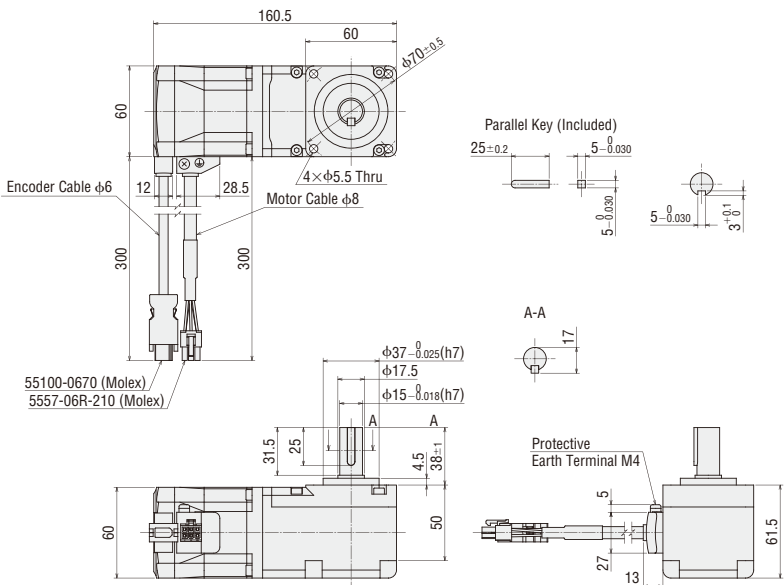

● The ■ within the product name includes a number expressing the gear ratio.

Features

System Configuration

Product Line

AC Input

Specifications and Features

Dimensions

Connection and Operation

System Configuration

Product Line

DC Input

Specifications and Features

Dimensions and Operation

Multi-axis Driver

Accessories

◇ FC Geared Type with Electromagnetic Brake  
 Frame Size 42 mm Cable Withdrawing Direction Up

| Product Name                  | Gear Ratio             | Mass kg |
|-------------------------------|------------------------|---------|
| <b>AZM46MC-FC</b> ■ <b>UA</b> | <b>7.2, 10, 20, 30</b> | 0.96    |

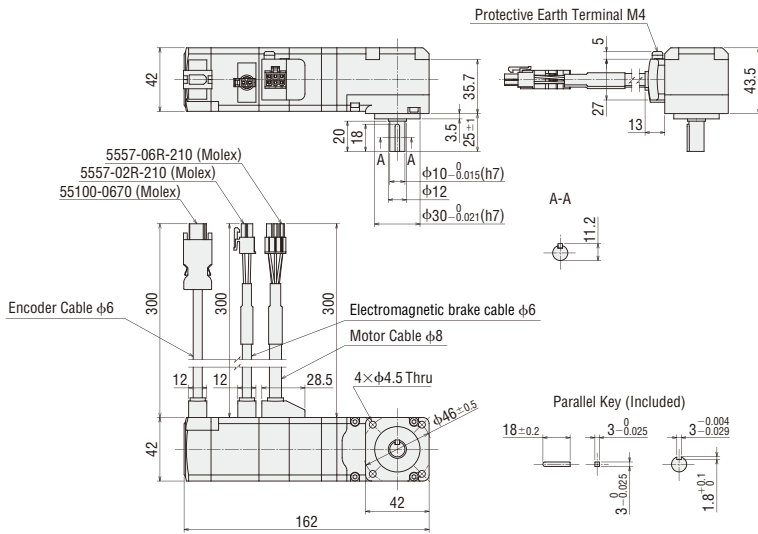

Frame Size 42 mm Cable Withdrawing Direction Down

| Product Name                  | Gear Ratio             | Mass kg |
|-------------------------------|------------------------|---------|
| <b>AZM46MC-FC</b> ■ <b>DA</b> | <b>7.2, 10, 20, 30</b> | 0.96    |

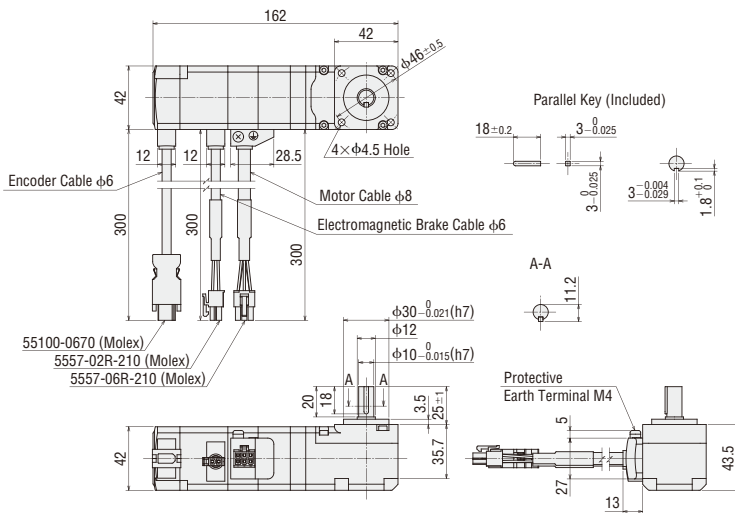

● The ■ within the product name includes a number expressing the gear ratio.

Frame Size 60 mm Cable Withdrawing Direction Up

| Product Name          | Gear Ratio             | Mass kg |
|-----------------------|------------------------|---------|
| <b>AZM66MC-FC</b> ■UA | <b>7.2, 10, 20, 30</b> | 2.2     |

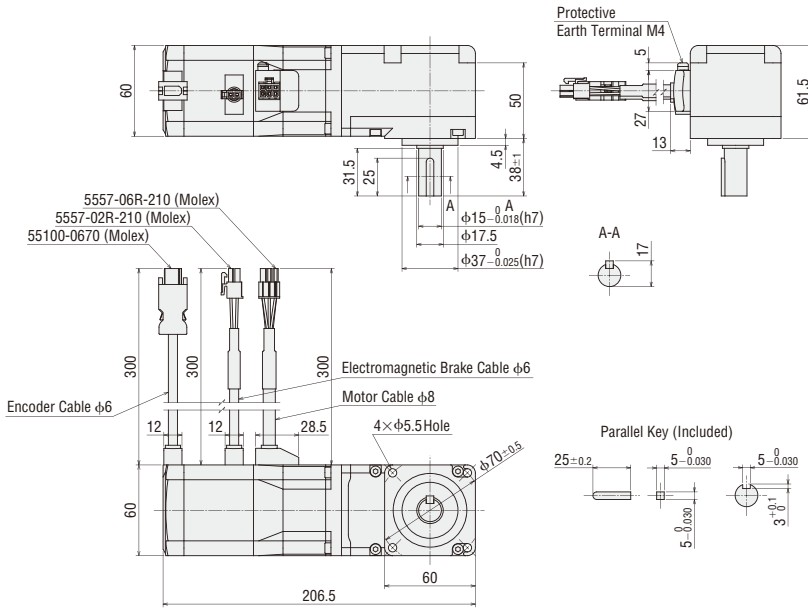

Frame Size 60 mm Cable Withdrawing Direction Down

| Product Name          | Gear Ratio             | Mass kg |
|-----------------------|------------------------|---------|
| <b>AZM66AC-MC</b> ■DA | <b>7.2, 10, 20, 30</b> | 2.2     |

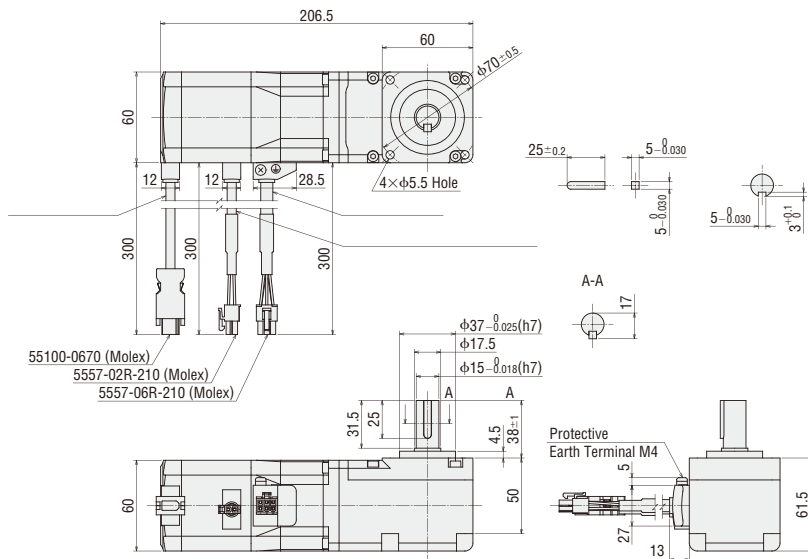

● The ■ within the product name includes a number expressing the gear ratio.

|          |                      |              |                             |            |                          |                      |              |                             |            |                          |                   |             |
|----------|----------------------|--------------|-----------------------------|------------|--------------------------|----------------------|--------------|-----------------------------|------------|--------------------------|-------------------|-------------|
| Features | System Configuration | Product Line | Specifications and Features | Dimensions | Connection and Operation | System Configuration | Product Line | Specifications and Features | Dimensions | Connection and Operation | Multi-axis Driver | Accessories |
|          |                      |              | AC Input                    |            |                          |                      |              |                             | DC Input   |                          |                   |             |

◆ **PS Geared Type**

**Frame Size 42 mm**

| Product Name        | Gear Ratio        | L     | Mass kg |
|---------------------|-------------------|-------|---------|
| <b>AZM46AC-PS</b> ■ | <b>5, 7.2, 10</b> | 98    | 0.64    |
|                     | <b>25, 36, 50</b> | 121.5 | 0.79    |

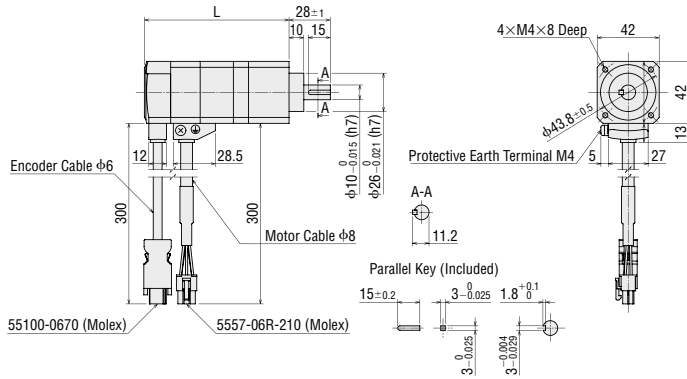

**Frame Size 60 mm**

| Product Name        | Gear Ratio        | L   | Mass kg |
|---------------------|-------------------|-----|---------|
| <b>AZM66AC-PS</b> ■ | <b>5, 7.2, 10</b> | 104 | 1.3     |
|                     | <b>25, 36, 50</b> | 124 | 1.6     |

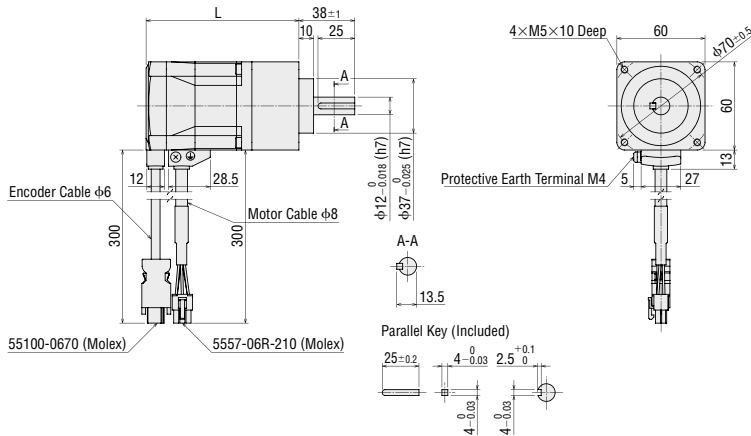

**Frame Size 90 mm**

| Product Name        | Gear Ratio        | L     | Mass kg |
|---------------------|-------------------|-------|---------|
| <b>AZM98AC-PS</b> ■ | <b>5, 7.2, 10</b> | 131   | 3.3     |
|                     | <b>25, 36, 50</b> | 158.5 | 4.1     |

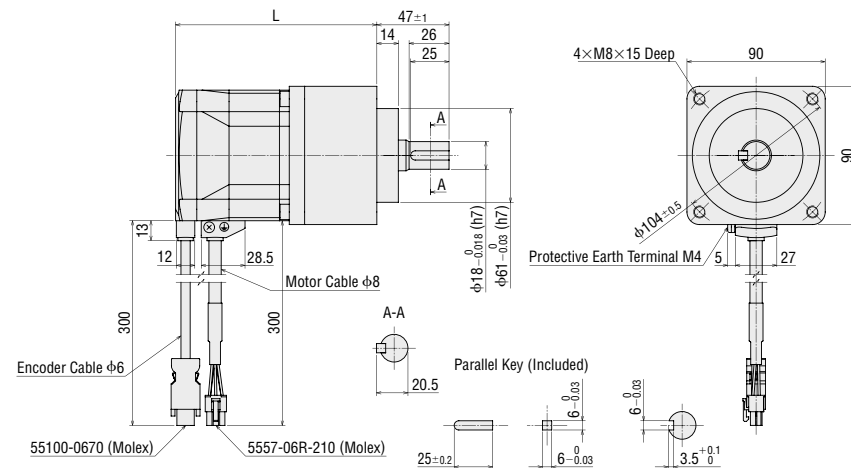

● The ■ within the product name includes a number expressing the gear ratio.

◆ PS Geared Type with Electromagnetic Brake

Frame Size 42 mm

| Product Name        | Gear Ratio        | L   | Mass kg |
|---------------------|-------------------|-----|---------|
| <b>AZM46MC-PS</b> ■ | <b>5, 7.2, 10</b> | 129 | 0.81    |
|                     | <b>25, 36, 50</b> | 152 | 0.96    |

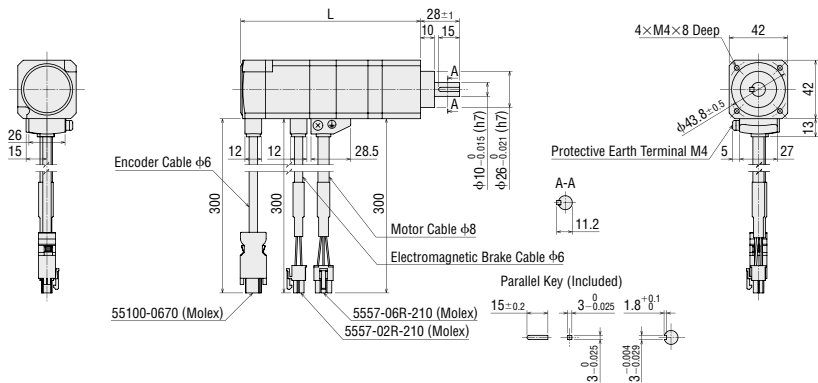

Frame Size 60 mm

| Product Name        | Gear Ratio        | L   | Mass kg |
|---------------------|-------------------|-----|---------|
| <b>AZM66MC-PS</b> ■ | <b>5, 7.2, 10</b> | 150 | 1.7     |
|                     | <b>25, 36, 50</b> | 170 | 2.0     |

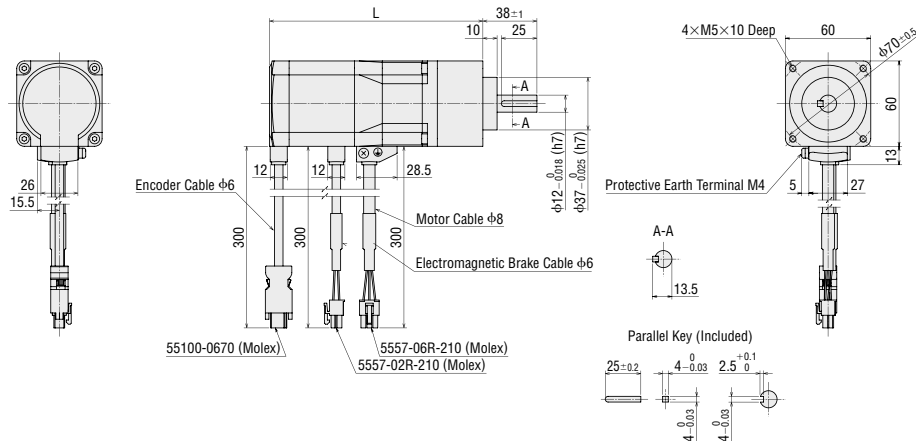

Frame Size 90 mm

| Product Name        | Gear Ratio        | L     | Mass kg |
|---------------------|-------------------|-------|---------|
| <b>AZM98MC-PS</b> ■ | <b>5, 7.2, 10</b> | 172.5 | 3.9     |
|                     | <b>25, 36, 50</b> | 200   | 4.7     |

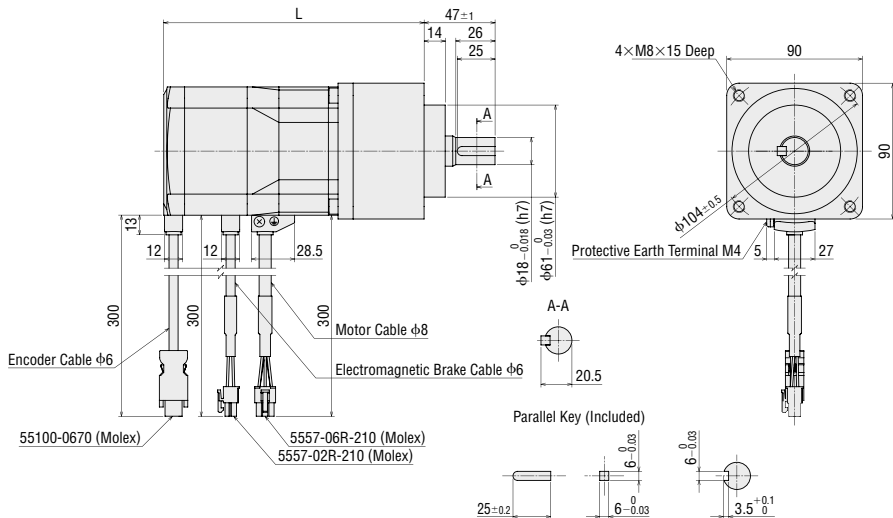

● The ■ within the product name includes a number expressing the gear ratio.

◇ **HPG Geared Type Shaft Output Type**  
**Frame Size 40 mm**

| Product Name        | Gear Ratio  | Mass kg |
|---------------------|-------------|---------|
| <b>AZM46AC-HP</b> ■ | <b>5, 9</b> | 0.71    |

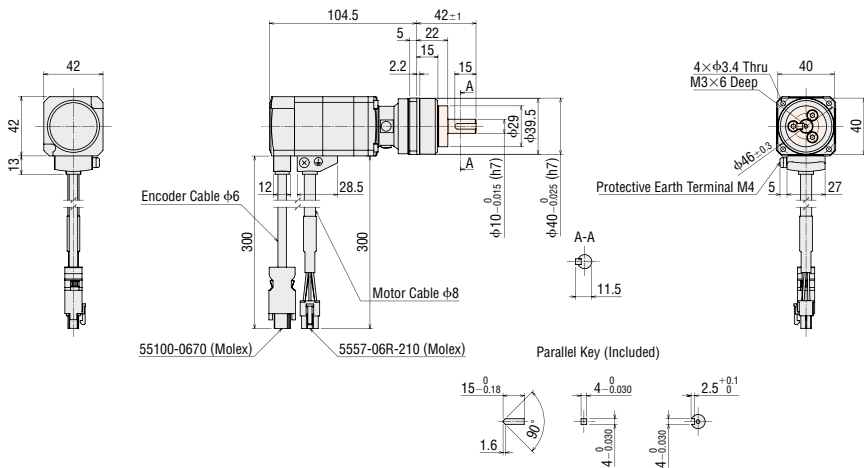

**Frame Size 60 mm**

| Product Name        | Gear Ratio   | Mass kg |
|---------------------|--------------|---------|
| <b>AZM66AC-HP</b> ■ | <b>5, 15</b> | 1.9     |

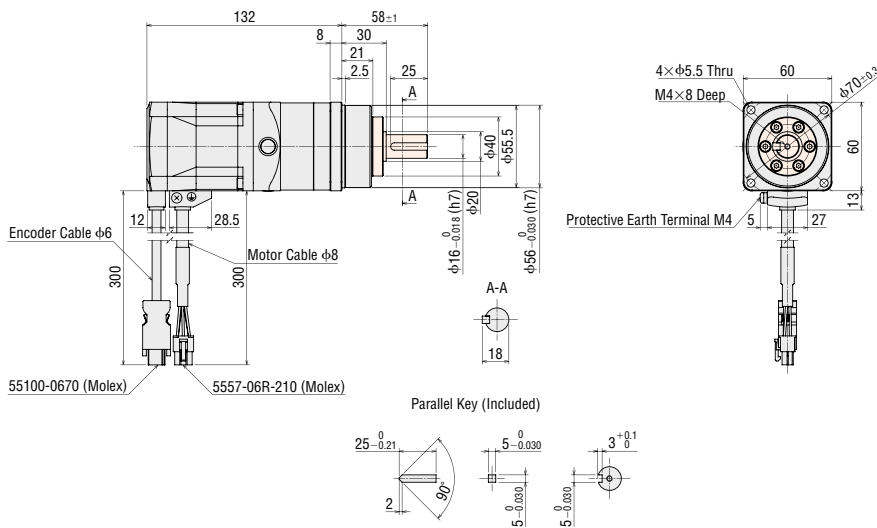

**Frame Size 90 mm**

| Product Name        | Gear Ratio   | Mass kg |
|---------------------|--------------|---------|
| <b>AZM98AC-HP</b> ■ | <b>5, 15</b> | 4.8     |

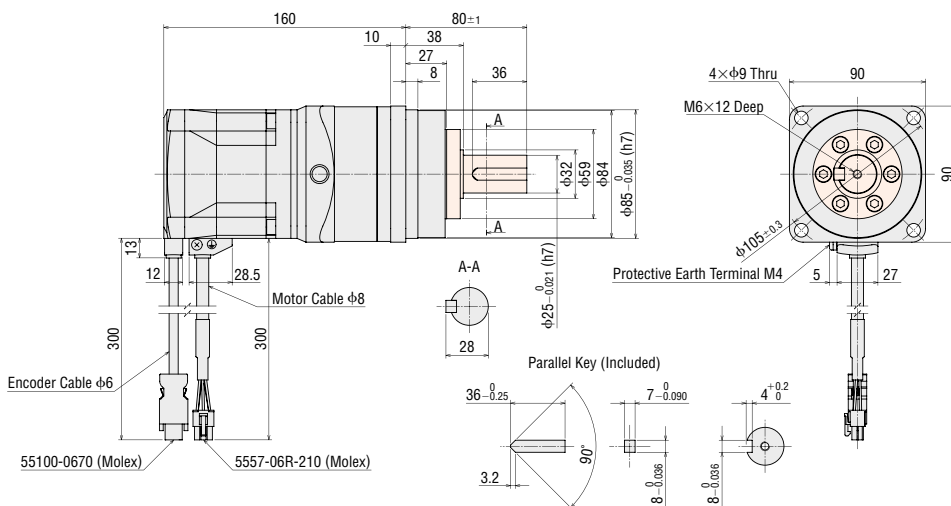

- The coloured part ■ of the outline drawing is the rotation section.
- The ■ within the product name includes a number expressing the gear ratio.



◆ **HPG Geared Type Flange Output Type**  
**Frame Size 40 mm**

| Product Name         | Gear Ratio  | Mass kg |
|----------------------|-------------|---------|
| <b>AZM46AC-HP</b> ■F | <b>5, 9</b> | 0.66    |

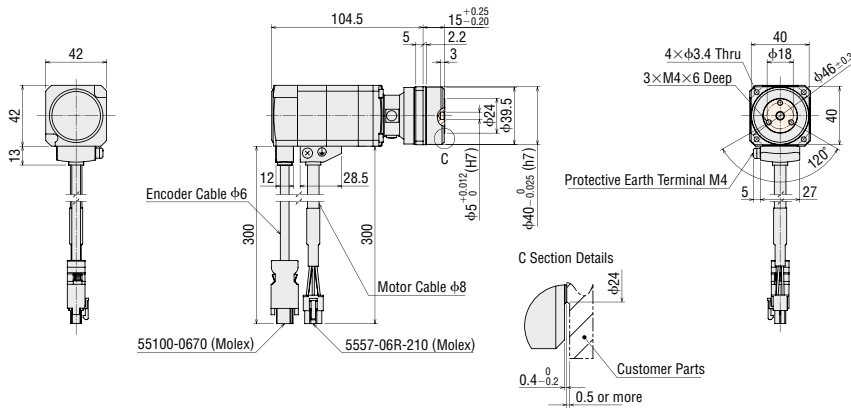

**Frame Size 60 mm**

| Product Name         | Gear Ratio   | Mass kg |
|----------------------|--------------|---------|
| <b>AZM66AC-HP</b> ■F | <b>5, 15</b> | 1.8     |

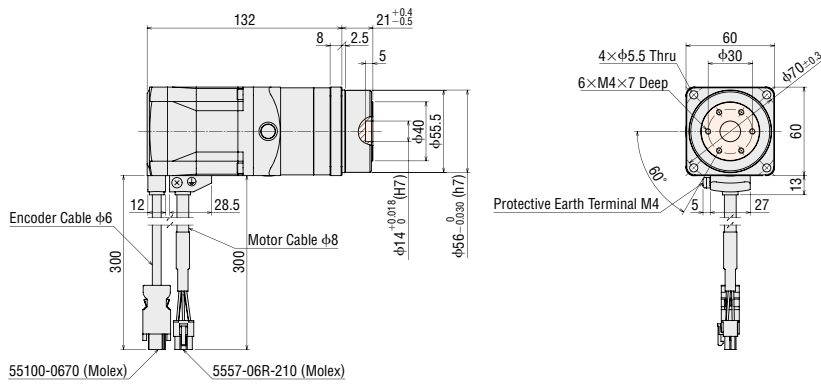

**Frame Size 90 mm**

| Product Name         | Gear Ratio | Mass kg |
|----------------------|------------|---------|
| <b>AZM98AC-HP</b> ■F | <b>5</b>   | 4.5     |
|                      | <b>15</b>  | 4.4     |

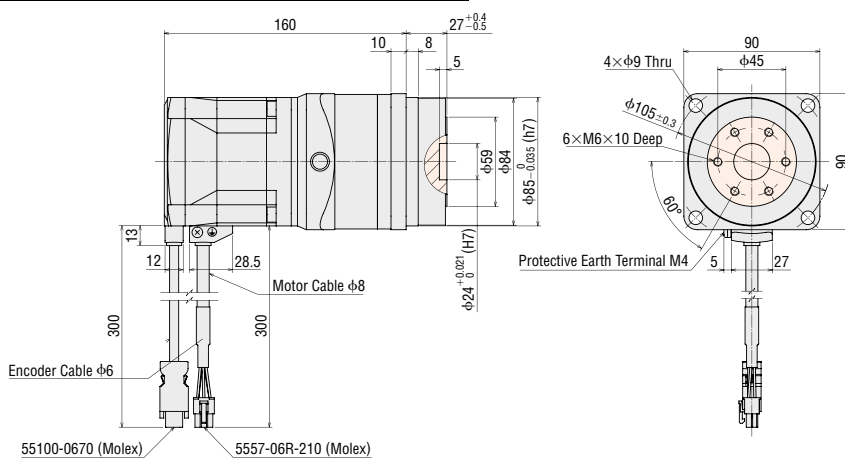

- The coloured part  of the outline drawing is the rotation section.
- The ■ within the product name includes a number expressing the gear ratio.

|          |                      |              |                             |            |                          |                      |              |                             |            |                          |                  |             |
|----------|----------------------|--------------|-----------------------------|------------|--------------------------|----------------------|--------------|-----------------------------|------------|--------------------------|------------------|-------------|
| Features | System Configuration | Product Line | Specifications and Features | Dimensions | Connection and Operation | System Configuration | Product Line | Specifications and Features | Dimensions | Connection and Operation | Multiaxis Driver | Accessories |
|----------|----------------------|--------------|-----------------------------|------------|--------------------------|----------------------|--------------|-----------------------------|------------|--------------------------|------------------|-------------|

◇ **HPG Geared Type with Electromagnetic Brake Shaft Output Type**  
**Frame Size 40 mm**

| Product Name      | Gear Ratio  | Mass kg |
|-------------------|-------------|---------|
| <b>AZM46MC-HP</b> | <b>5, 9</b> | 0.88    |

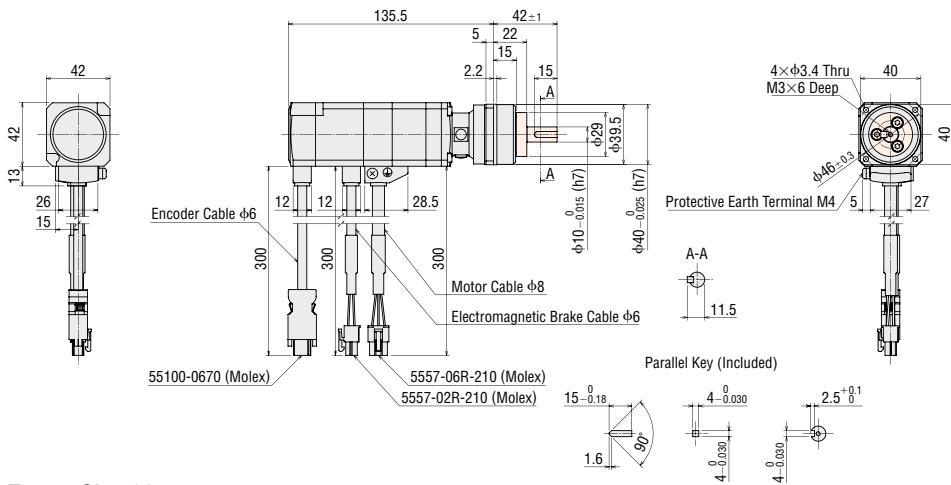

**Frame Size 60 mm**

| Product Name      | Gear Ratio   | Mass kg |
|-------------------|--------------|---------|
| <b>AZM66MC-HP</b> | <b>5, 15</b> | 2.3     |

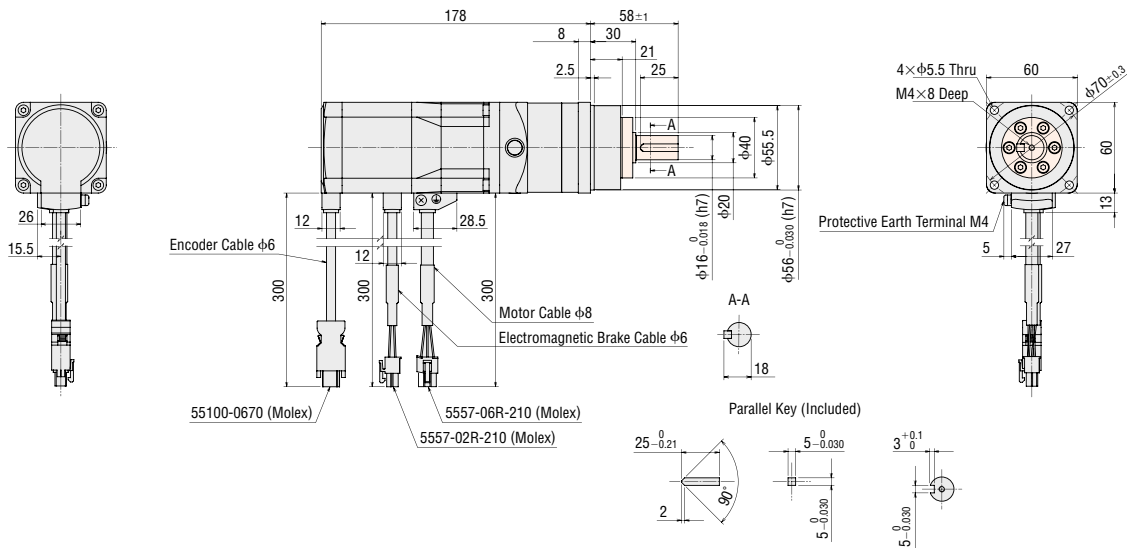

**Frame Size 90 mm**

| Product Name      | Gear Ratio   | Mass kg |
|-------------------|--------------|---------|
| <b>AZM98MC-HP</b> | <b>5, 15</b> | 5.4     |

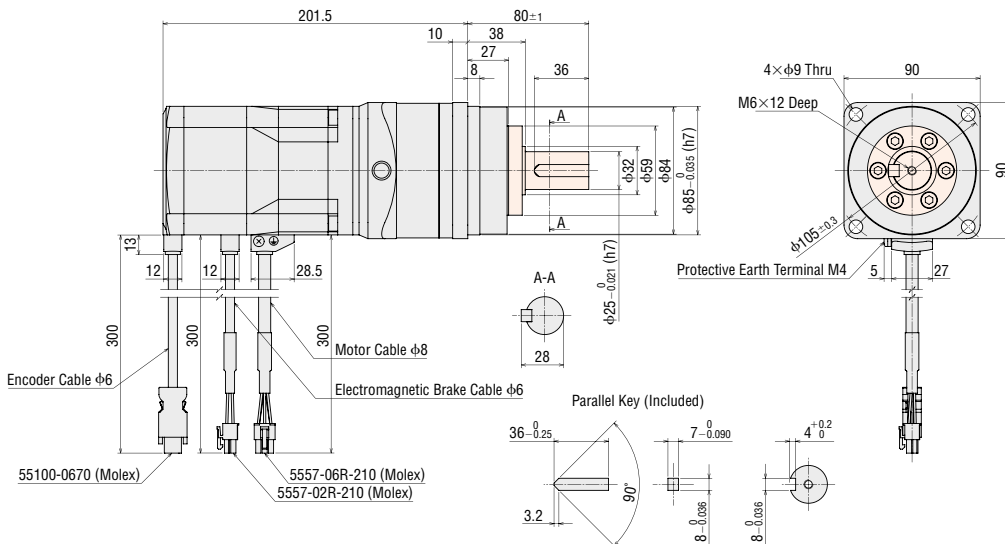

- The coloured part  of the outline drawing is the rotation section.
- The  within the product name includes a number expressing the gear ratio.

◆ **HPG Geared Type with Electromagnetic Brake Flange Output Type**  
**Frame Size 40 mm**

| Product Name         | Gear Ratio  | Mass kg |
|----------------------|-------------|---------|
| <b>AZM46MC-HP</b> ■F | <b>5, 9</b> | 0.83    |

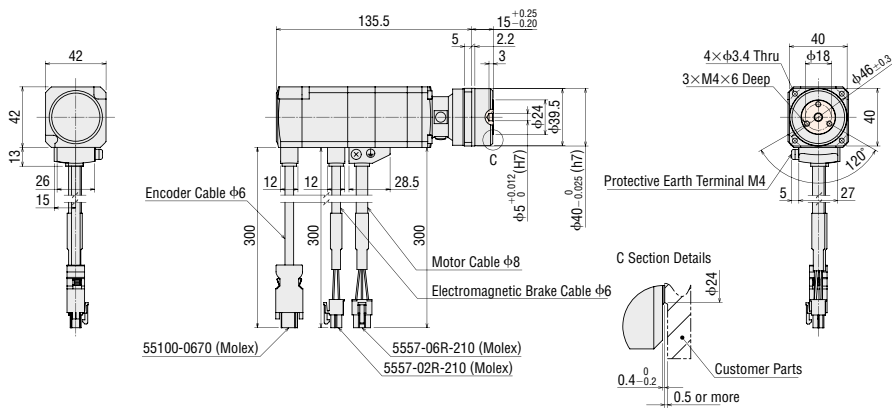

**Frame Size 60 mm**

| Product Name         | Gear Ratio   | Mass kg |
|----------------------|--------------|---------|
| <b>AZM66MC-HP</b> ■F | <b>5, 15</b> | 2.2     |

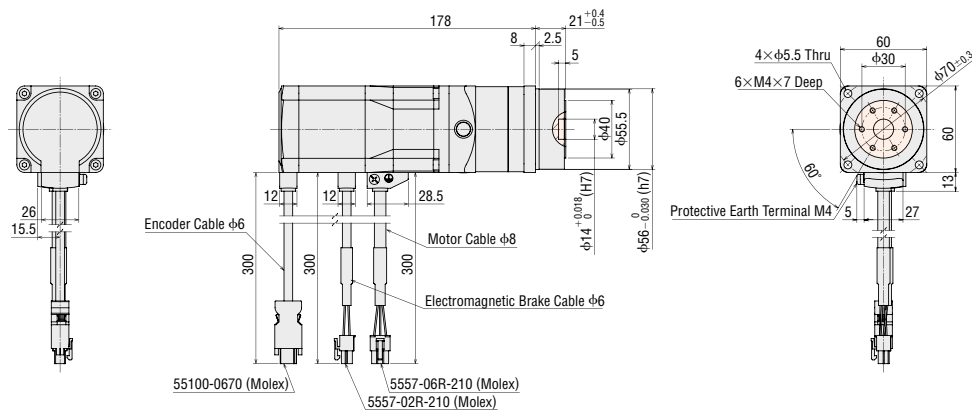

**Frame Size 90 mm**

| Product Name         | Gear Ratio | Mass kg |
|----------------------|------------|---------|
| <b>AZM98MC-HP</b> ■F | <b>5</b>   | 5.1     |
|                      | <b>15</b>  | 5       |

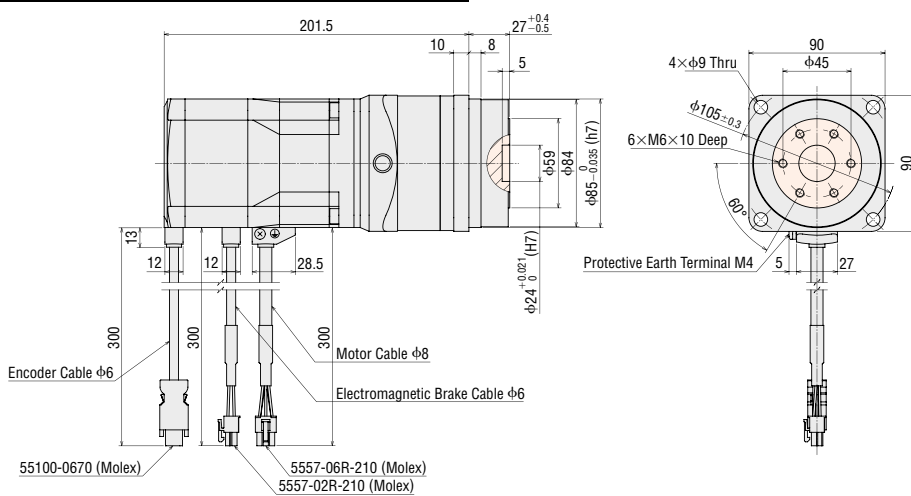

- The coloured part  of the outline drawing is the rotation section.
- The ■ within the product name includes a number expressing the gear ratio.

**Features**  
**System Configuration**  
**Product Line**  
**Specifications and Features**  
**AC Input**  
**Dimensions**  
**Connection and Operation**  
**System Configuration**  
**Product Line**  
**Specifications and Features**  
**DC Input**  
**Dimensions**  
**Connection and Operation**  
**Multiaxis Driver**  
**Accessories**

## ◇ Harmonic Geared Type

### Frame Size 42 mm

| Product Name   | Gear Ratio     | Mass kg |
|--|----------------|---------|
| <b>AZM46AC-HS</b> <span style="background-color: #e0e0e0; border: 1px solid black; padding: 0 2px;"> </span> | <b>50, 100</b> | 0.65    |

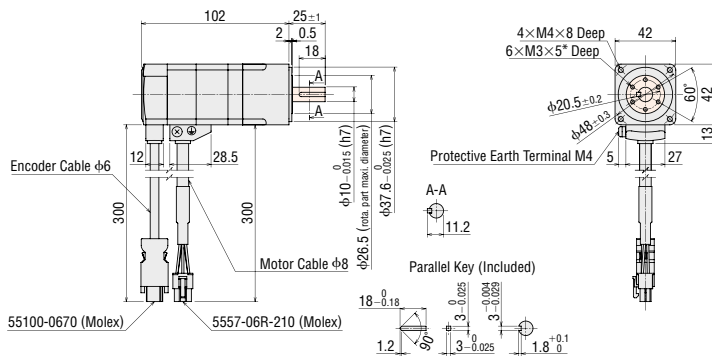

\*The position of the output shaft relative to the screw holes on the rotating part cannot be specified. Adjust the position via the size of the screw holes on the load installation surface.

### Frame Size 60 mm

| Product Name   | Gear Ratio     | Mass kg |
|--|----------------|---------|
| <b>AZM66AC-HS</b> <span style="background-color: #e0e0e0; border: 1px solid black; padding: 0 2px;"> </span> | <b>50, 100</b> | 1.4     |

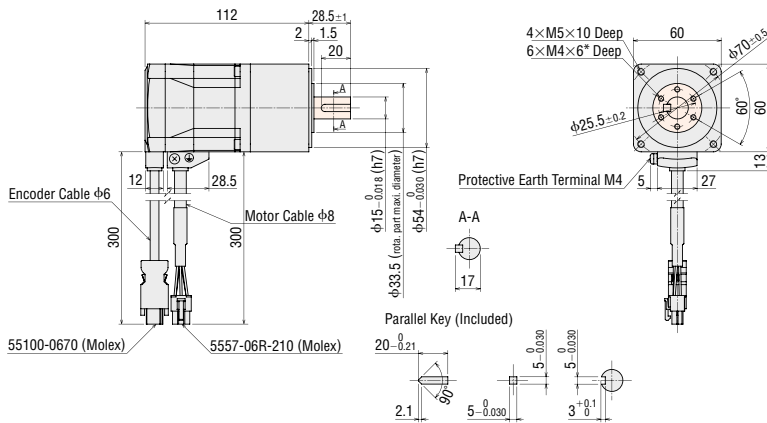

\*The position of the output shaft relative to the screw holes on the rotating part cannot be specified. Adjust the position via the size of the screw holes on the load installation surface.

### Frame Size 90 mm

| Product Name   | Gear Ratio     | Mass kg |
|--|----------------|---------|
| <b>AZM98AC-HS</b> <span style="background-color: #e0e0e0; border: 1px solid black; padding: 0 2px;"> </span> | <b>50, 100</b> | 3.9     |

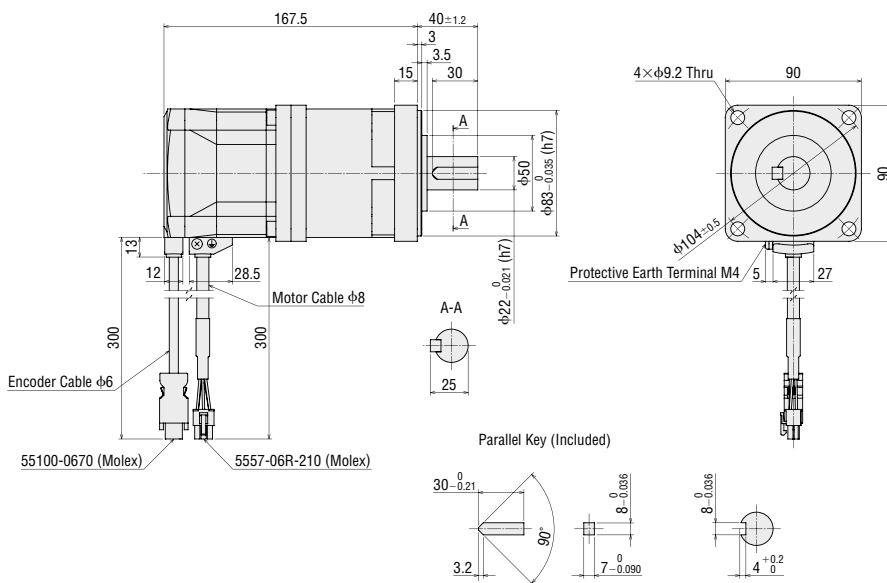

- The coloured part   of the outline drawing is the rotation section.
- The   within the product name includes a number expressing the gear ratio.

### ◇ Harmonic Geared Type with Electromagnetic Brake

#### Frame Size 42 mm

| Product Name      | Gear Ratio     | Mass kg |
|-------------------|----------------|---------|
| <b>AZM46MC-HS</b> | <b>50, 100</b> | 0.82    |

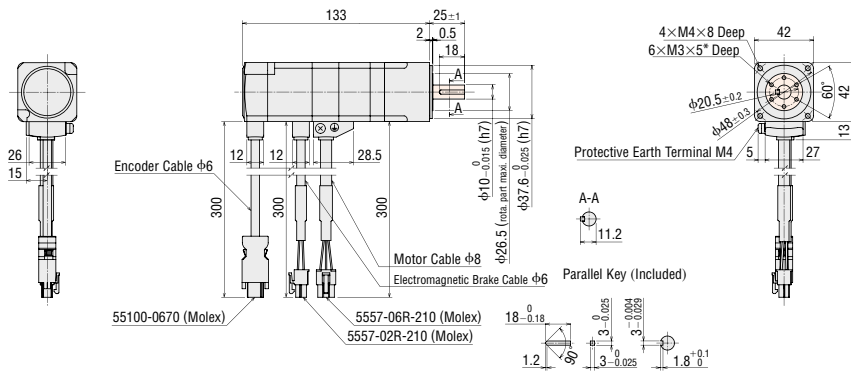

\*The position of the output shaft relative to the screw holes on the rotating part cannot be specified. Adjust the position via the size of the screw holes on the load installation surface.

#### Frame Size 60 mm

| Product Name      | Gear Ratio     | Mass kg |
|-------------------|----------------|---------|
| <b>AZM66MC-HS</b> | <b>50, 100</b> | 1.8     |

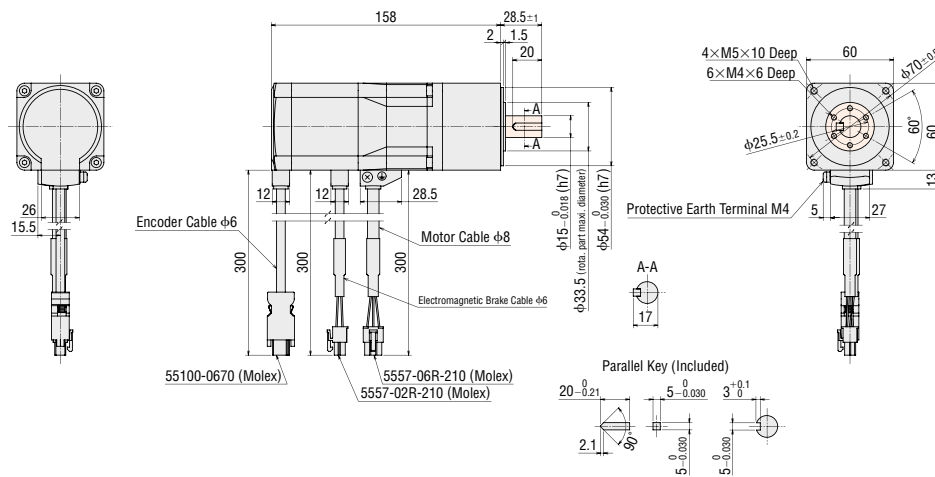

\*The position of the output shaft relative to the screw holes on the rotating part cannot be specified. Adjust the position via the size of the screw holes on the load installation surface.

#### Frame Size 90 mm

| Product Name      | Gear Ratio     | Mass kg |
|-------------------|----------------|---------|
| <b>AZM98MC-HS</b> | <b>50, 100</b> | 4.5     |

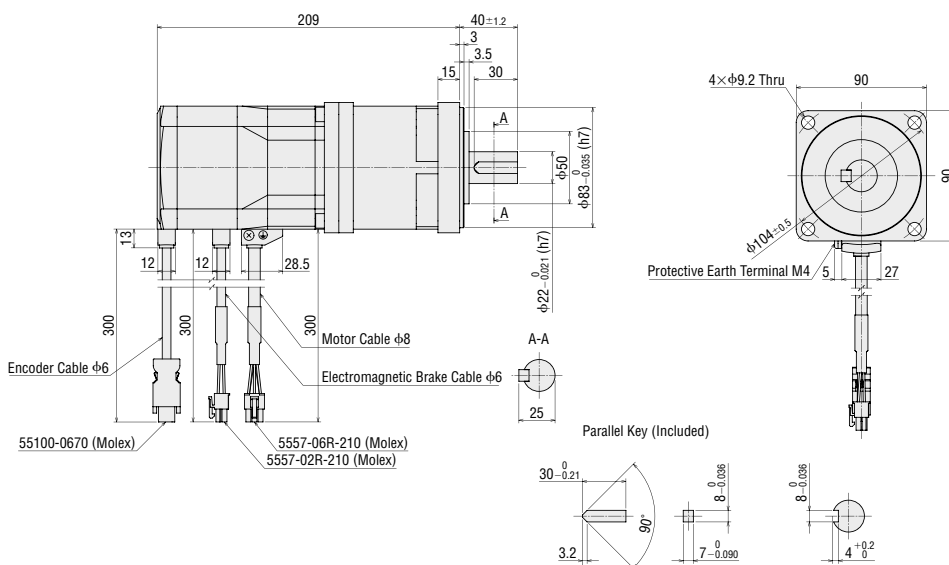

- The coloured part  of the outline drawing is the rotation section.
- The  within the product name includes a number expressing the gear ratio.

● Drivers

◇ Built-in Controller Type, Pulse-Input Type with RS-485 Communication

Driver Product Name: **AZD-CD, AZD-CX**

Mass: 0.65 kg

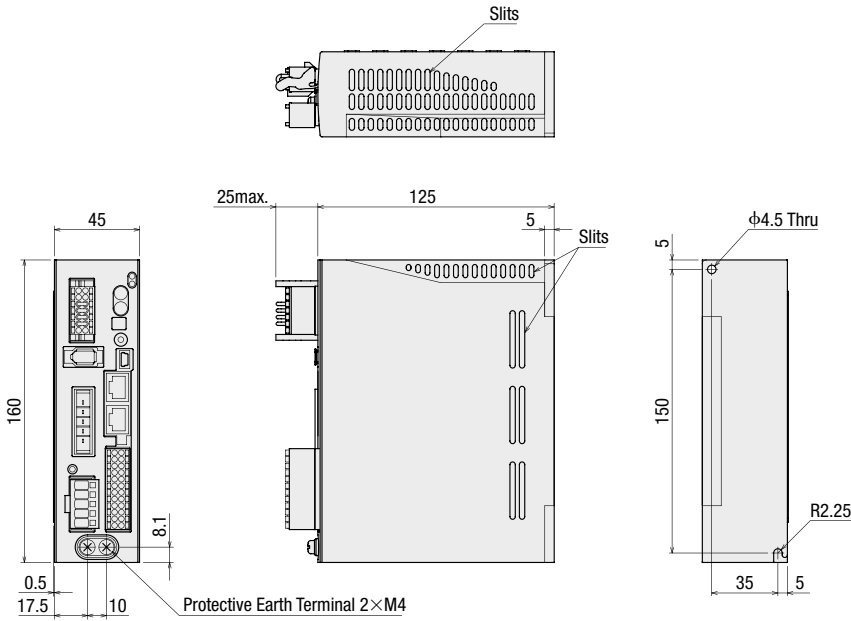

● Accessories

Connector for Main Power Supply/Regeneration Unit (CN4)

Connector: 05JFAT-SAXGDK-H5.0  
(JST Mfg. Co., Ltd.)

Connector for Input/Output Signal (CN5)

Connector: DFMC1,5/12-ST-3,5  
(PHOENIX CONTACT GmbH & Co. KG)

Connector for 24 VDC Power Supply Input/Regeneration Unit Thermal Input/Electromagnetic Brake Output Terminal (CN1)

Connector: DFMC1,5/7-ST-3,5-LR  
(PHOENIX CONTACT GmbH & Co. KG)

Lever for Connector: J-FAT-0T  
(JST Mfg. Co., Ltd.)

◇ Pulse-Input Type

Driver Product Name: **AZD-C**

Mass: 0.65 kg

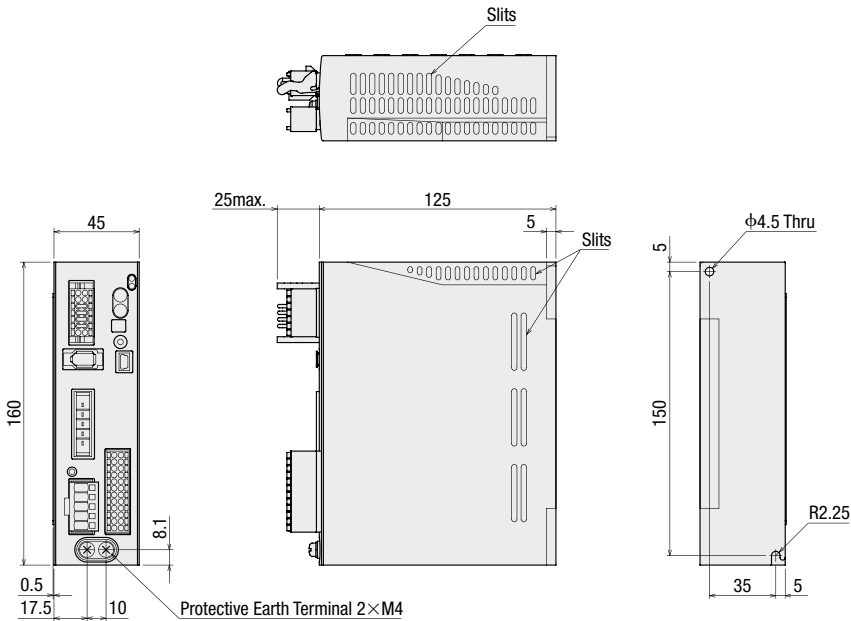

● Accessories

Connector for Main Power Supply/Regeneration Unit (CN4)

Connector: 05JFAT-SAXGDK-H5.0  
(JST Mfg. Co., Ltd.)

Connector for Input/Output Signal (CN5)

Connector: DFMC1,5/12-ST-3,5  
(PHOENIX CONTACT GmbH & Co. KG)

Connector for 24 VDC Power Supply Input/Regeneration Unit Thermal Input/Electromagnetic Brake Output Terminal (CN1)

Connector: DFMC1,5/7-ST-3,5-LR  
(PHOENIX CONTACT GmbH & Co. KG)

Lever for Connector: J-FAT-0T  
(JST Mfg. Co., Ltd.)

● Cable for Motor (sold separately), Cable for Encoder (sold separately), Cable for Electromagnetic Brake (sold separately)

● Only products with included connection cables

◇ Cable for Motor

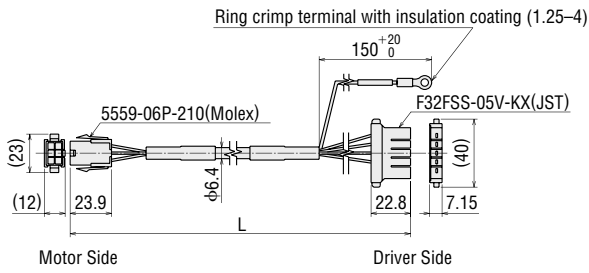

◇ Cable for Electromagnetic Brake (Only for electromagnetic brake products)

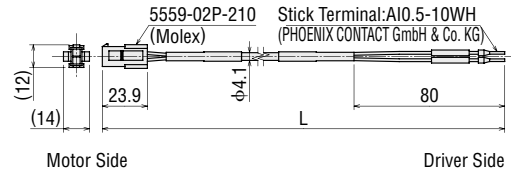

◇ Cable for Encoder

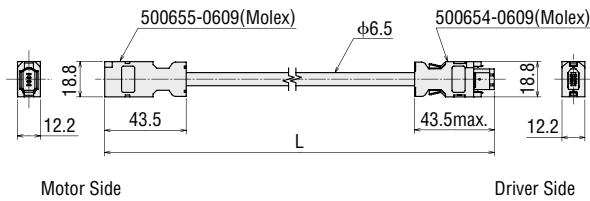

\*The length L (m) is specified where L is located in the dimensions in "Product Line" on page 19.

**Notes**

● The motor cable and the electromagnetic brake cable coming out of the motor cannot be connected directly to the driver. For connection to the driver use the accessory connection cable (sold separately) or the connection cable which is included to the product (for products with included cable).

|             |                             |
|-------------|-----------------------------|
| AC Input    | Features                    |
|             | System Configuration        |
|             | Product Line                |
|             | Specifications and Features |
| DC Input    | Dimensions                  |
|             | Connection and Operation    |
|             | System Configuration        |
|             | Product Line                |
| Accessories | Specifications and Features |
|             | Dimensions                  |
|             | Connection and Operation    |
|             | Multiaxis Driver            |

# Connection and Operation (Built-in Controller Type / Pulse-Input Type with RS-485 Communication)

## Name and Functions of Driver Parts

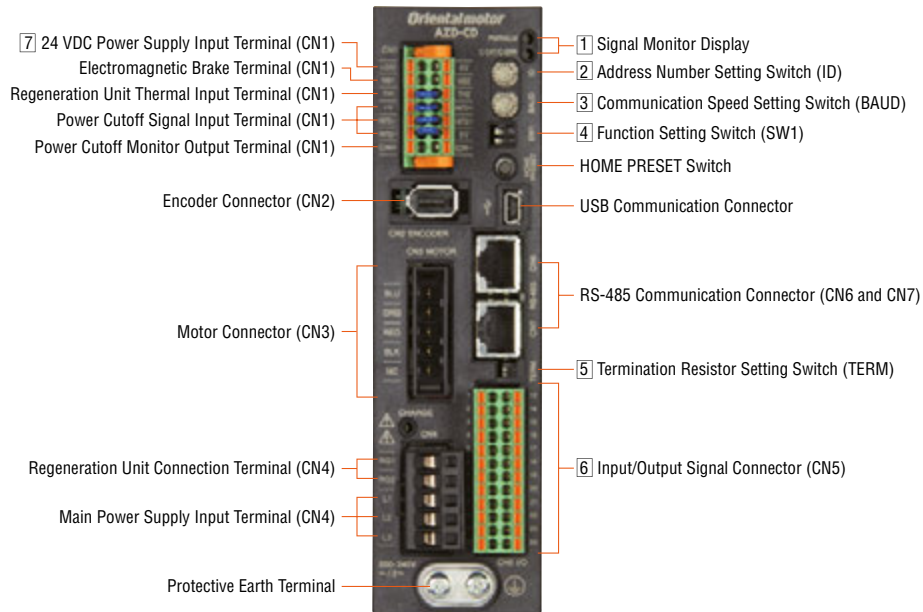

### 1 Signal Monitor Displays

#### ◇ LED Displays

| Display | Colour | Function                    | When Activated                                  |
|---------|--------|-----------------------------|---|
| PWR     | Green  | Power Display               | When 24 VDC power is on.                        |
| ALM     | Red    | Alarm Display               | Blinks when protective functions are activated. |
| C-DAT   | Green  | Communication Display       | When communication data is received or sent.    |
| C-ERR   | Red    | Communication Error Display | When there is an error with communication data. |

### 2 Address Number Setting Switch (ID)

| Display | Function   |
|---------|--|
| ID      | Set the address number for RS-485 communication<br>(Factory Setting:<br>Built-in controller type : 0.<br>Pulse input with RS-485 communication type : 1) |

### 3 Communication Speed Setting Switch

| Display | Function  |
|---------|---|
| BAUD    | Set this when using RS-485 communications. Set the communication speed<br>(Factory Setting:<br>Built-in controller type : 7.<br>Pulse input with RS-485 communication type : 4) |

### 4 Function Setting Switch

| Display | No. | Function  |
|---------|-----|---|
| SW1     | 1   | This sets the address number in combination with the address number setting switch (ID)<br>(Factory Setting: OFF).                                  |
|         | 2   | Set the protocol of RS-485 communication<br>(Factory Setting:<br>Built-in controller type: OFF.<br>Pulse input with RS-485 communication type : ON) |

#### ◇ Settings of the RS-485 Communication Speed

| No. | Baud Rate (bps)   |
|-----|-------------------|
| 0   | 9600              |
| 1   | 19200             |
| 2   | 38400             |
| 3   | 57600             |
| 4   | 115200            |
| 5   | 230400            |
| 6   | Not used          |
| 7   | Network Converter |
| 8-F | Not used          |



## 5 Termination Resistor Setting Switch

| Display | No. | Function  |
|---------|-----|---|
| TERM    | 1   | Set the RS-485 communication terminal resistor (120Ω) (Factory Setting: OFF) .<br>OFF: no terminal resistor, ON: terminal resistor connected. |
|         | 2   |   |

● Please use the same settings for both No. 1 and No. 2.

## 6 Input/Output Signal Connector (CN5)

For the Pulse-Input Type with RS-485 Communication pin No. 1, 2, 13 and 14 are for pulse input. For connecting to a programmable controller refer to page 63-64 of the Pulse-Input Type.

| Display | Pin Number | Driver Type                                | Signal Name            | Content   |   |
|---------|------------|--|------------------------|---|---|
| CN5     | 1          | Built-In Controller Type                   | IN0                    | START   | This signal is used to start positioning operation.   |
|         |            | Pulse-Input Type with RS-485 Communication | CW+*<br>[PLS+]         | CW Pulse Input+<br>[Pulse Input+]               | Pulse signal for motor operation in CW direction with 2 pulse input method. The brackets [ ] show the content when using 1 pulse input method.  |
|         | 2          | Built-In Controller Type                   | IN2                    | M1  | Use the 3 bits of M0, M1, M2, to select the drive data No.  |
|         |            | Pulse-Input Type with RS-485 Communication | CCW+*<br>[DIR+]        | CCW Pulse Input+<br>[Rotation Direction Input+] | Pulse signal for motor operation in CCW direction with 2 pulse input method. The brackets [ ] show the content when using 1 pulse input method. |
|         | 3          | Common                                     | IN4                    | ZHOME   | Move to the home position set with the HOME PRESET switch.  |
|         | 4          | Common                                     | IN6                    | STOP  | Stop the motor.   |
|         | 5          | Common                                     | IN-COM [0-7]*          | IN0-IN7 input common                            |   |
|         | 6          | Common                                     | IN8                    | FW-JOG  | Start JOG operation.  |
|         | 7          | Common                                     | OUT0                   | HOME-END  | Output when determining the home position or completing high speed return-to-home operation.  |
|         | 8          | Common                                     | OUT2                   | PLS-RDY   | Not used  |
|         | 9          | Common                                     | OUT4                   | MOVE  | Output while operating the motor.   |
|         | 10         | Common                                     | OUT-COM*               | Output common                                   |   |
|         | 11         | Common                                     | ASG+                   | A phase pulse output+                           |   |
|         | 12         | Common                                     | BSG+                   | B phase pulse output+                           |   |
|         | 13         | Built-In Controller Type                   | IN1                    | M0  | Use the 3 bits of M0, M1, M2, to select the drive data No.  |
|         |            | Pulse-Input Type with RS-485 Communication | CW-*<br>[PLS-]         | CW-*<br>[PLS-]                                  | Pulse signal for motor operation in CW direction with 2 pulse input method. The brackets [ ] show the content when using 1 pulse input method.  |
|         | 14         | Built-In Controller Type                   | IN3                    | M2  | Use the 3 bits of M0, M1, M2, to select the drive data No.  |
|         |            | Pulse-Input Type with RS-485 Communication | CCW-*<br>[DIR-]        | CCW Pulse Input+<br>[Rotation Direction Input+] | Pulse signal for motor operation in CCW direction with 2 pulse input method. The brackets [ ] show the content when using 1 pulse input method. |
|         | 15         | Common                                     | IN5                    | FREE  | The motor is set to non-excitation.   |
|         | 16         | Common                                     | IN7                    | ALM-RST   | Reset the alarm.  |
|         | 17         | Common                                     | IN-COM [8-9]*          | IN8, IN9 input common                           |   |
|         | 18         | Common                                     | IN9                    | RV-JOG  | Start JOG operation.  |
|         | 19         | Common                                     | OUT1                   | IN-POS  | Output when the motor operation is complete.  |
|         | 20         | Common                                     | OUT3                   | READY   | Output when the driver is ready for operation.  |
| 21      | Common     | OUT5                                       | ALM-B                  | Output the driver alarm state (normal close).   |   |
| 22      | Common     | GND* <sup>1)</sup>                         | Ground                 |   |   |
| 23      | Common     | ASG-                                       | A phase pulse output - |   |   |
| 24      | Common     | BSG-                                       | B phase pulse output - |   |   |

● Assigned functions are set by means of the parameter settings. The above is the initial value. For details, refer to the User's Manual.

\* The initial value setting cannot be changed.

## 7 24 VDC Input/Electromagnetic Brake Connection Terminal/Regeneration Unit Thermal Input/Power Cutoff Signal Input Terminal/Power Cutoff Monitor Output Terminal (CN1)

| Display | Input/Output | Terminal Name                              | Content  |
|---------|--------------|--|--|
| +24 V   | Input        | 24 VDC Power Input Terminal+               | This is the driver control circuit power. Be sure to connect this.   |
| 0 V     |              | 24 VDC Power Input Terminal-               |  |
| MB1     | Output       | Electromagnetic Brake Connection Terminal- | Connect the cable for Electromagnetic Brake Connection Terminal.   |
| MB2     |              | Electromagnetic Brake Connection Terminal+ |  |
| TH1     | Input        | Regeneration Unit Thermal Input Terminal   | Connect the optional regenerative resistance ( <b>RGB100</b> ) (sold separately).<br>When not connecting the regenerative resistance, short circuit between the terminals ( <b>RGB100</b> ). |
| TH2     |              | Regeneration Unit Thermal Input Terminal   |  |
| HWT01+  | Input        | Drive Cutoff Signal Input Terminal 1+      | Connect the switch and programmable controller.<br>When either HWT01 input or HWT02 input is OFF, the electricity to the motor is cut directly by hardware without the CPU.                  |
| HWT01-  |              | Drive Cutoff Signal Input Terminal 1-      |  |
| HWT02+  |              | Drive Cutoff Signal Input Terminal 2+      |  |
| HWT02-  |              | Drive Cutoff Signal Input Terminal 2-      |  |
| EDM+    | Output       | Drive Cutoff Signal Input Terminal+        | Connect the programmable controller.<br>When both HWT01 input and HWT02 input are OFF, EDM output becomes ON.  |
| EDM-    |              | Drive Cutoff Signal Input Terminal-        |  |

## ● Connection Diagram

### ◇ Connection to Peripheral Equipment

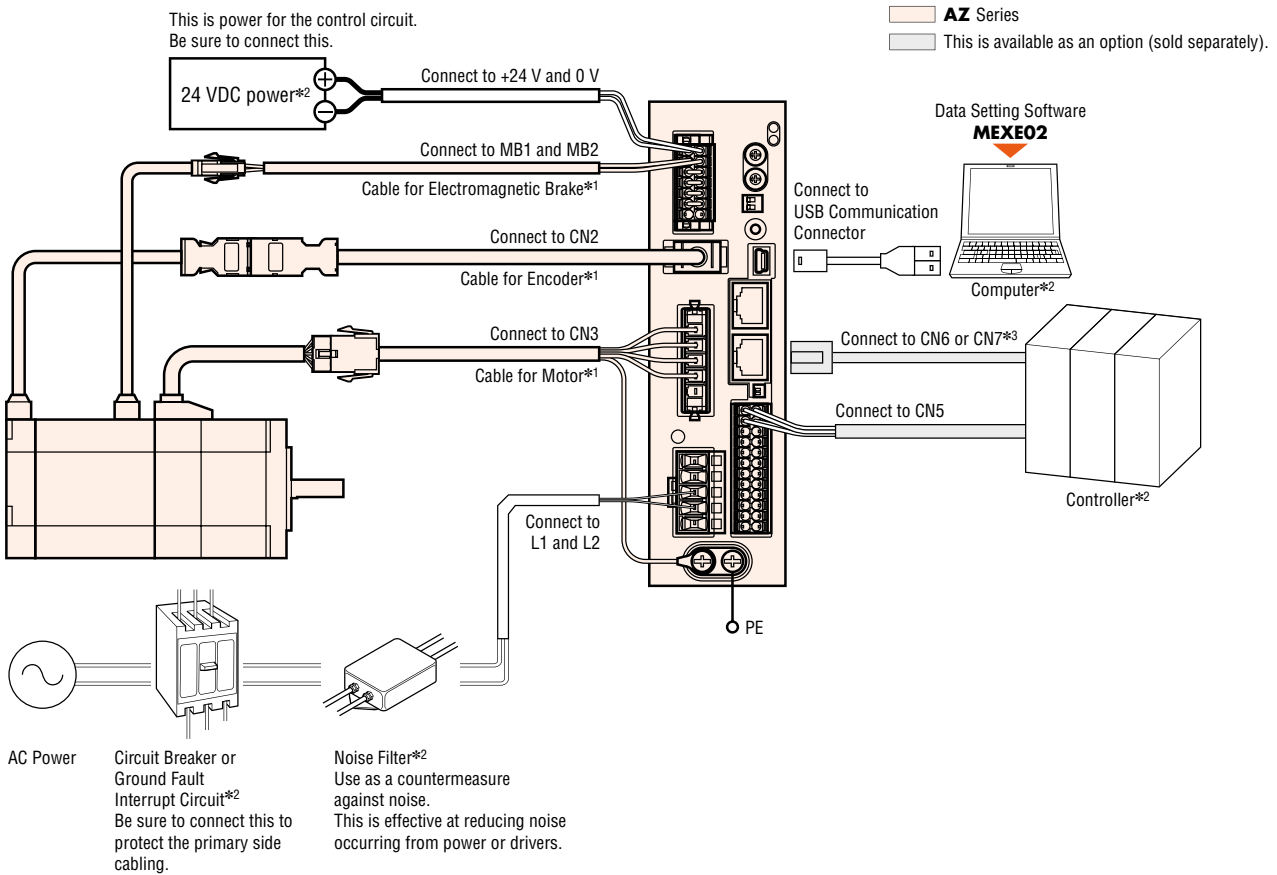

\*1 Make sure a cabling distance between the motor and the driver is 20 m or less.

\*2 Prepared by the customer.

\*3 When controlling with RS-485 communications, connect to the controller.

### ◇ Connecting a Main Power Supply

The connection method differs according to the power supply specification.

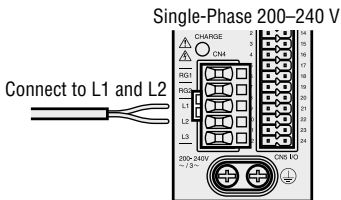

### ◇ USB Cable Connection

The computer on which the data setting software **MEXE02** is installed and driver are connected with a USB cable.

Use the following specifications for the USB cable.

|               |                       |
|---------------|-----------------------|
| Specification | USB2.0 (full speed)   |
| Cable         | Length: 3 m (or less) |
|               | Format: A-mini-B      |

◇ Connecting to a Host Controller

● Connecting to a Current Sink Output Circuit

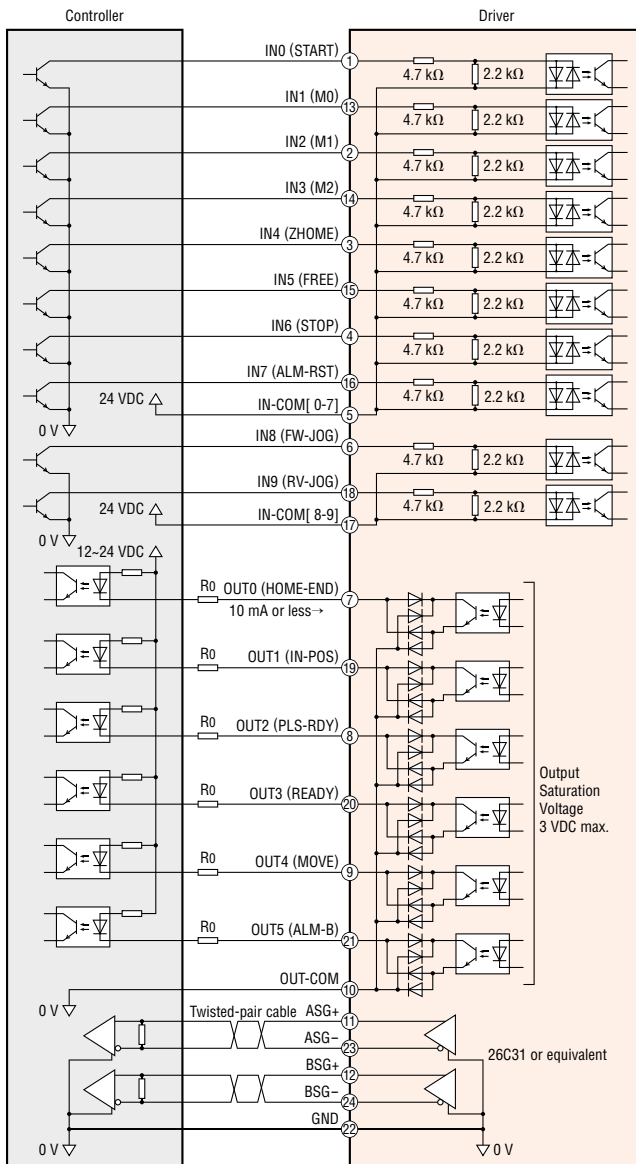

**Notes**

- For the input signal, use 24 VDC.
- For the output signal, use 12~24 VDC 10 mA or less. Where the current value exceeds 10 mA, connect an external resistor  $R_0$  to reduce the current to 10 mA or less.
- Make sure the signal line is wired at a distance of 200 mm or longer from the power lines (power supply line and motor line). Further, do not insert the signal line in the same pipe as the power lines or bundle them together.
- When noise is emitted from the motor cable or power cable due to wiring or allocation and it cause a problem, use shields or ferrite cores.

● Connecting to a Current Source Output Circuit

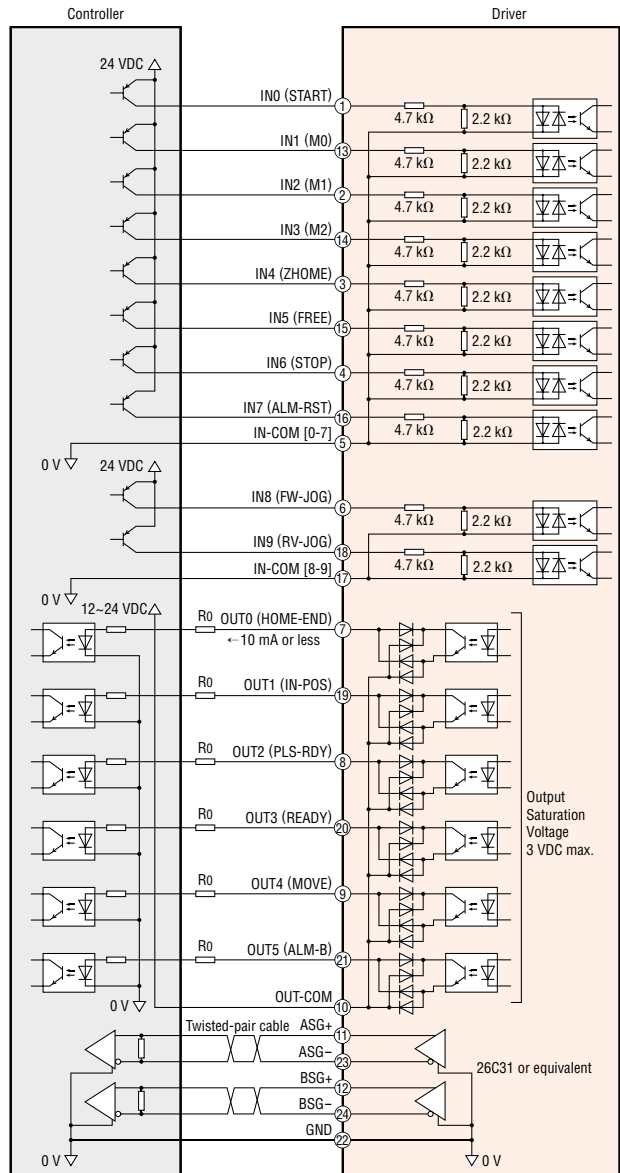

**Notes**

- For the input signal, use 24 VDC.
- For the output signal, use 12~24 VDC 10 mA or less. Where the current value exceeds 10 mA, connect an external resistor  $R_0$  to reduce the current to 10 mA or less.
- Make sure the signal line is wired at a distance of 200 mm or longer from the power line (power supply line and motor line). Further, do not insert the signal line in the same pipe as the power lines or bundle them together.
- When noise is emitted from the motor cable or power cable due to wiring or allocation and it cause a problem, use shields or ferrite cores.

◇ Connecting to a Programmable Controller (Pulse-Input Type with RS-485 Communication)

The connection diagram is the same like that of the Pulse-Input Type. See page 63-64

|                             |
|-----------------------------|
| Features                    |
| System Configuration        |
| Product Line                |
| Specifications and Features |
| AC Input                    |
| Dimensions                  |
| Connection and Operation    |
| System Configuration        |
| Product Line                |
| Specifications and Features |
| DC Input                    |
| Dimensions                  |
| Connection and Operation    |
| Multiaxis Driver            |
| Accessories                 |

## Connection and Operation (Pulse-Input Type)

### Names and Functions of Driver Parts

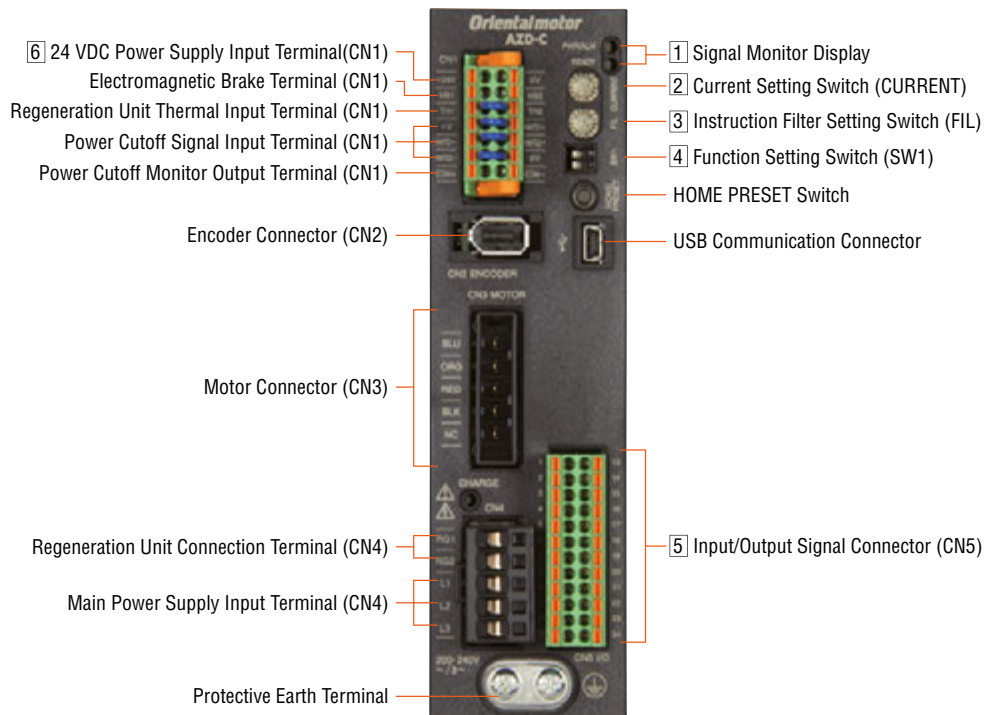

#### 1 Signal Monitor Displays

##### ◇ LED Display

| Display | Colour | Function      | When Activated                                  |
|---------|--------|---------------|---|
| PWR     | Green  | Power Display | When 24 VDC power is on.                        |
| ALM     | Red    | Alarm Display | Blinks when protective functions are activated. |
| READY   | Green  | READY Output  | When READY output is set to ON.                 |

#### 2 Current Setting Switch

| Display | Function  |
|---------|---|
| CURRENT | Set basic current that is the base for the operation current and stop current (Factory Setting: F). |

#### 3 Command Filter Setting Switch

| Display | Function   |
|---------|--|
| FIL     | Adjust the responsiveness of the motor (Factory Setting: 1). |

#### 4 Function Setting Switch

| Display | No. | Function  |
|---------|-----|---|
| SW1     | 1   | Sets the resolution per one rotation of the motor output shaft: OFF [1000 p/r] (Factory Setting); ON [10000 p/r]    |
|         | 2   | Sets the pulse input format to 1 pulse input mode or 2 pulse input mode. (Factory Setting: OFF[2 pulse input mode]) |

## 5 Input/Output Signal Connector (CN4)

| Display | Pin Number | Signal Name    | Content  |
|---------|------------|----------------|--|
| CN4     | 1          | CW+[PLS+]*1    | CW pulse input+[pulse input+] Pulse signal for motor operation in CW direction with 2 pulse input method. The brackets [ ] show the content when using 1 pulse input method.                 |
|         | 2          | CCW+[DIR+]*1   | CCW pulse input+[rotation direction input+] Pulse signal for motor operation in CCW direction with 2 pulse input method. The brackets [ ] show the content when using 1 pulse input method.  |
|         | 3          | IN4            | ZHOME Move to the home position set with the HOME PRESET switch.   |
|         | 4          | IN6            | STOP Stop the motor.   |
|         | 5          | IN-COM [4-7]*1 | IN4-IN7 input common   |
|         | 6          | IN8            | FW-JOG Start JOG operation.  |
|         | 7          | OUT0           | HOME-END Output when determining the home position or completing high speed return-to-home operation.  |
|         | 8          | OUT2           | PLS-RDY Output when the pulse input preparation is complete.   |
|         | 9          | OUT4           | MOVE Output while operating the motor.   |
|         | 10         | OUT-COM*1      | Output common  |
|         | 11         | ASG+           | A phase pulse output+  |
|         | 12         | BSG+           | B phase pulse output+  |
|         | 13         | CW-[PLS-]*1    | CW pulse input-[pulse input-] Pulse signal for motor operation in CW direction with 2 pulse input method. The brackets [ ] show the content when using 1 pulse input method.                 |
|         | 14         | CCW-[DIR-]*1   | CCW pulse input-[rotation direction input -] Pulse signal for motor operation in CCW direction with 2 pulse input method. The brackets [ ] show the content when using 1 pulse input method. |
|         | 15         | IN5            | FREE The motor is set to non-excitation.   |
|         | 16         | IN7            | ALM-RST Reset the alarm.   |
|         | 17         | IN-COM [8-9]*1 | IN8, IN9 input common  |
|         | 18         | IN9            | RV-JOG Start JOG operation.  |
|         | 19         | OUT1           | IN-POS Output when the motor operation is complete.  |
|         | 20         | OUT3           | READY Outputs when the driver is ready for operation.  |
|         | 21         | OUT5           | ALM-B Output the driver alarm state (normal close).  |
|         | 22         | GND*1          | Ground   |
|         | 23         | ASG-           | A phase pulse output-  |
|         | 24         | BSG-           | B phase pulse output-  |

● Assigned functions are set by means of the parameter settings. The above is the initial value. For details, refer to the User's Manual.

\*1 The initial value setting cannot be changed.

## 6 24 VDC Assigned functions are set by means of the parameter settings. The above is the initial value. For details, refer to the User's Manual. (CN1)

| Display | Input/Output | Terminal Name                            | Content   |
|---------|--------------|--|---|
| +24 V   | Input        | 24 VDC Power Input Terminal +            | This is the driver control circuit power. Be sure to connect this.  |
| 0 V     |              | 24 VDC Power Input Terminal -            |   |
| MB1     | Output       | Electromagnetic Brake Terminal -         | Connect the cable for electromagnetic brake of the electromagnetic brake type motor.  |
| MB2     |              | Electromagnetic Brake Terminal +         |   |
| TH1     | Input        | Regeneration Unit Thermal Input Terminal | Connect the optional regenerative resistance ( <b>RGB100</b> ) (sold separately). When not connecting the regenerative resistance, short circuit between the terminals ( <b>RGB100</b> ). |
| TH2     |              | Regeneration Unit Thermal Input Terminal |   |
| HWT01 + | Input        | Drive Cutoff Signal Input Terminal 1 +   | Connect the switch and programmable controller. When either HWT01 input or HWT02 input is OFF, the electricity to the motor is cut directly by hardware without the CPU.                  |
| HWT01 - |              | Drive Cutoff Signal Input Terminal 1 -   |   |
| HWT02 + |              | Drive Cutoff Signal Input Terminal 2 +   |   |
| HWT02 - |              | Drive Cutoff Signal Input Terminal 2 -   |   |
| EDM +   | Output       | Drive Cutoff Monitor Output Terminal +   | Connect the programmable controller. When both HWT01 input and HWT02 input are OFF, EDM output becomes ON.  |
| EDM -   |              | Drive Cutoff Monitor Output Terminal -   |   |

## ● Connection Diagram

### ◇ Connection to Peripheral Equipment

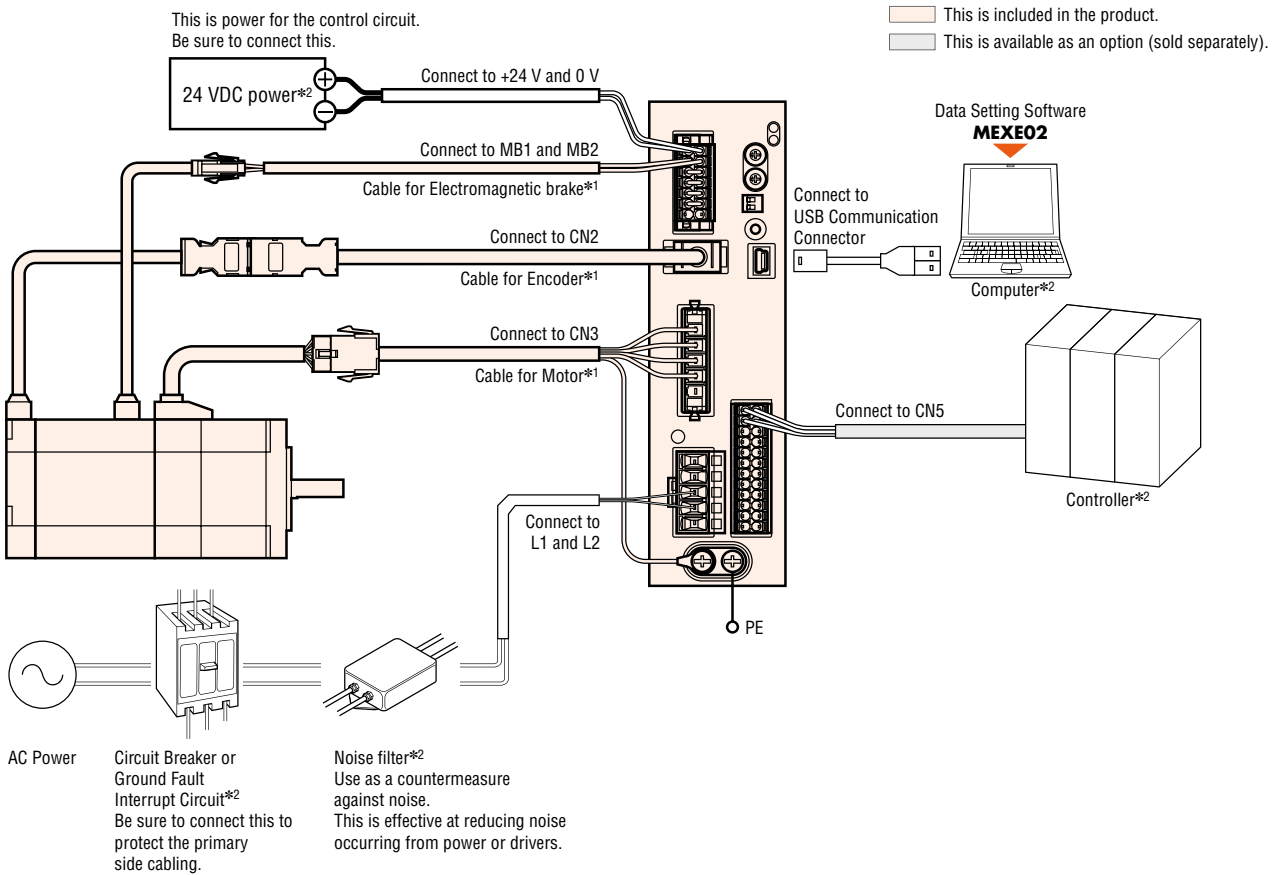

\*1 Make sure a cabling distance between the motor and the driver is 20 m or less.

\*2 Prepared by the customer.

### ◇ Connecting a Main Power Supply

The connection method differs according to the power supply specification.

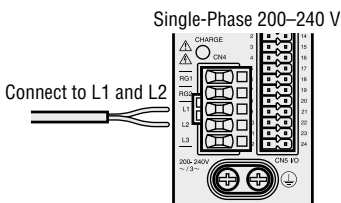

### ◇ USB Cable Connection

The computer on which the data setting software **MEXE02** is installed and driver are connected with a USB cable.

Use the following specifications for the USB cable.

|               |                       |
|---------------|-----------------------|
| Specification | USB2.0 (full speed)   |
| Cable         | Length: 3 m (or less) |
|               | Format: A-mini-B      |

## ◇ Connecting to a Host Controller

### ● Connecting to a Current Sink Output Circuit

When the pulse input is a line driver

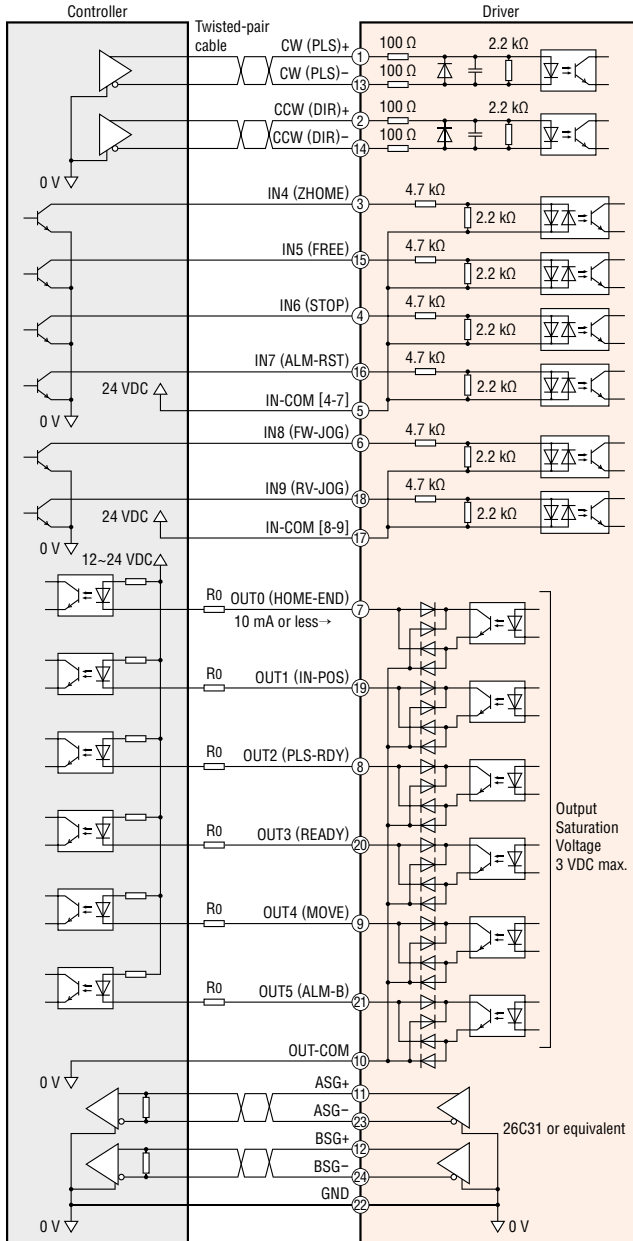

#### Notes

- For the input signal, use 24 VDC.
- For the output signal, use 12~24 VDC 10 mA or less. Where the current value exceeds 10 mA, connect the external resistance  $R_0$  to reduce the current to 10 mA or less.
- Make sure the signal line is wired at a distance of 200 mm or longer from the power line (power supply line and motor line). Furthermore, do not insert the signal line in the same pipe as the power lines or bundle them together.
- When noise is emitted from the motor cable or power cable due to wiring or allocation and it cause a problem, use shields or ferrite cores.

When the pulse input is an open collector

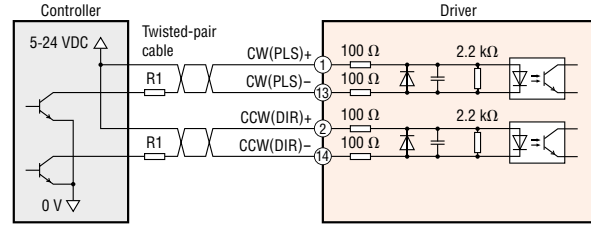

#### Notes

- For CW (PLS) input and CCW (DIR) input, use 5~24 VDC. Where the voltage exceeds 5 VDC, connect the external resistance  $R_1$  to adjust the input current to be 7~20 mA.

|                             |
|-----------------------------|
| Features                    |
| System Configuration        |
| Product Line                |
| Specifications and Features |
| AC Input                    |
| Dimensions                  |
| Connection and Operation    |
| System Configuration        |
| Product Line                |
| Specifications and Features |
| DC Input                    |
| Dimensions                  |
| Connection and Operation    |
| Multiaxis Driver            |
| Accessories                 |

## ◇ Connecting to a Host Controller

### ● Connecting to a Current Source Output Circuit

When the pulse input is a line driver

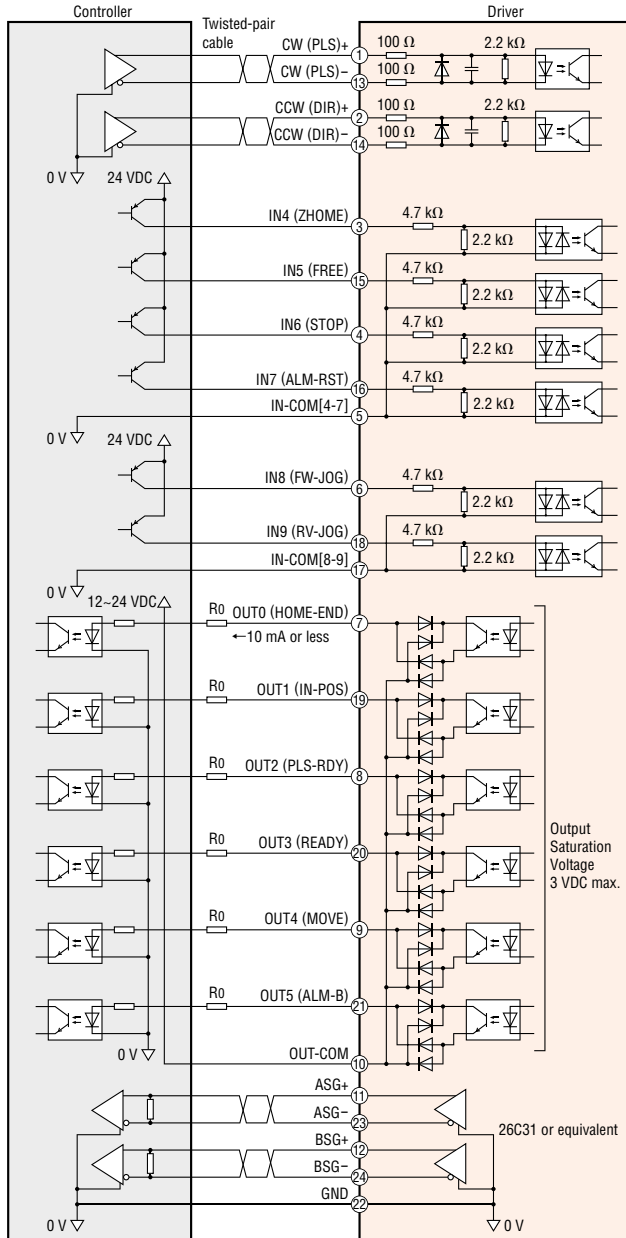

#### Notes

- For the input signal, use 24 VDC.
- For the output signal, use 12~24 VDC 10 mA or less. Where the current value exceeds 10 mA, connect to external resistance  $R_0$  to reduce the current to 10 mA or less.
- Make sure the signal line is wired at a distance of 200 mm or longer from the power line (power supply line and motor line). Furthermore, do not insert the signal line in the same pipe as the power lines or bundle them together.
- When noise is emitted from the motor cable or power cable due to wiring or allocation and it cause a problem, use shields or ferrite cores.

When the pulse input is an open collector

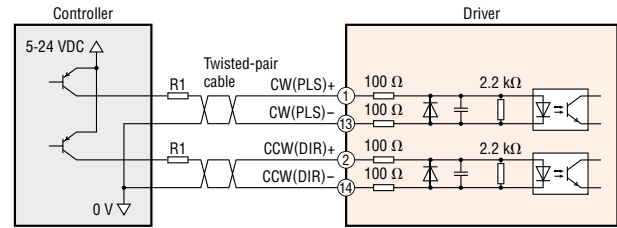

#### Notes

- For CW (PLS) input and CCW (DIR) input, use 5~24 VDC. Where the voltage exceeds 5 VDC, connect the external resistance  $R_1$  to adjust the input current to be 7~20 mA.



|          |                      |              |                             |            |                          |                      |              |                             |            |                          |                  |             |
|----------|----------------------|--------------|-----------------------------|------------|--------------------------|----------------------|--------------|-----------------------------|------------|--------------------------|------------------|-------------|
| Features | System Configuration | Product Line | Specifications and Features | Dimensions | Connection and Operation | System Configuration | Product Line | Specifications and Features | Dimensions | Connection and Operation | Multiaxis Driver | Accessories |
|          | AC Input             |              |                             |            |                          | DC Input             |              |                             |            |                          |                  |             |

## System Configuration

### Combination of Standard Type Motor with Electromagnetic Brake and Built-in Controller Type Driver or Pulse-Input Type Driver with RS-485 Communication

An example of a configuration using I/O control or RS-485 communication is shown below.  
Motors, drivers, and cables must be ordered individually.

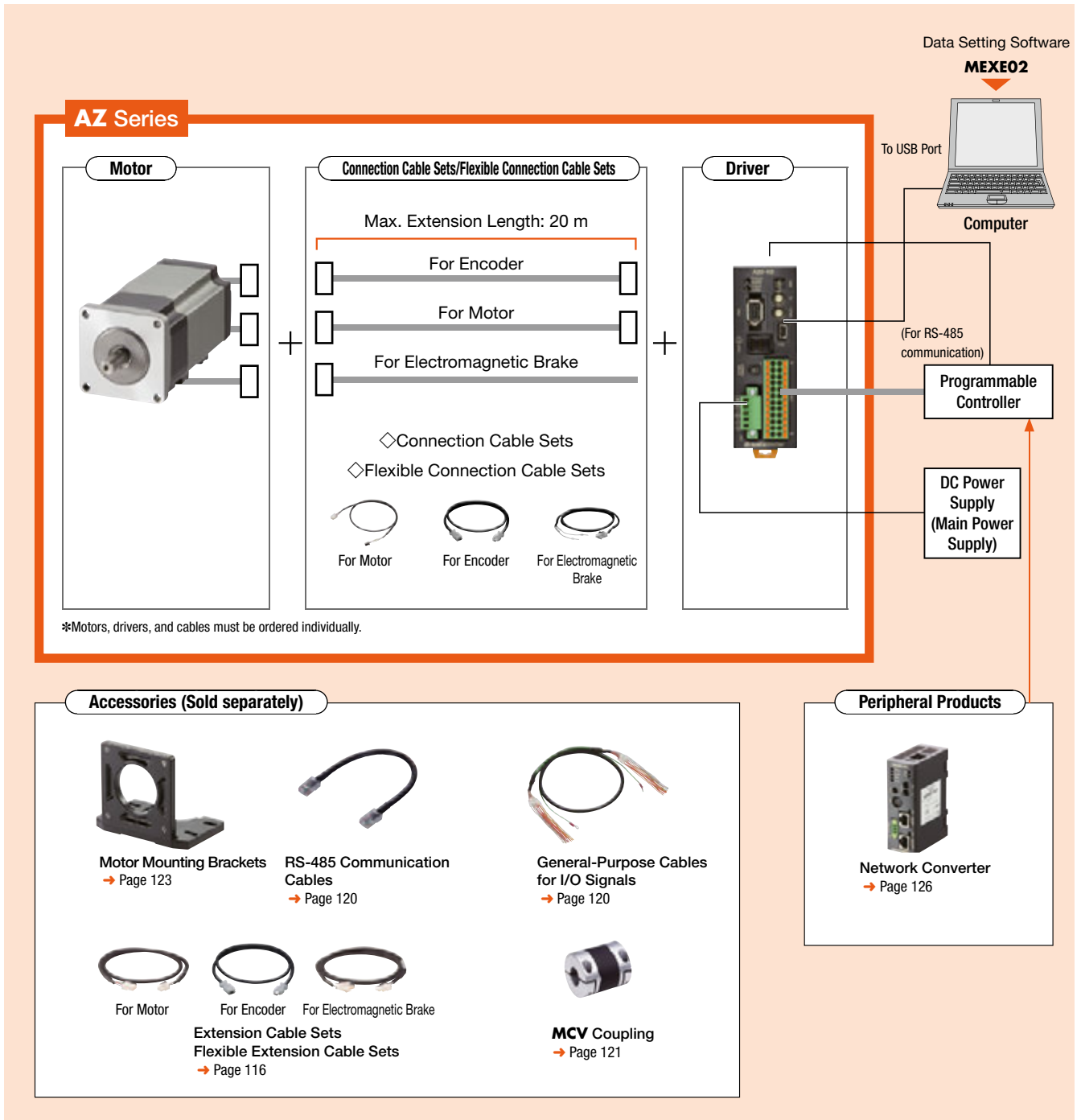

### System Configuration Example

| AZ Series      |               |                       | Accessory              |                   |  |
|----------------|---------------|-----------------------|------------------------|-------------------|--|
| Motor          | Driver        | Connection Cable Sets | Sold Separately        |                   |  |
| <b>AZM66MK</b> | <b>AZD-KD</b> | <b>CC030VZFB2</b>     | Motor Mounting Bracket | Flexible Coupling | General-Purpose Cables for I/O Signals (1 m) |
| €447.00        | €360.00       | €63.00                | <b>PAL2P-5</b>         | <b>MCV251010</b>  | <b>CC16D010B-1</b>                           |
|                |               |                       | €13.00                 | €53.00            | €21.00                                       |

The system configuration shown above is an example. Other combinations are also available.

#### Note

The motor cable and electromagnetic brake cable from the motor cannot be connected directly to the driver. When connecting to a driver, use a connection cable.

● **Combination of Standard Type Motor with Electromagnetic Brake and Pulse Input Type Driver**

An example of a single-axis system configuration with the **SCX11** controller is shown below.

Motors, drivers, and cables must be ordered individually.

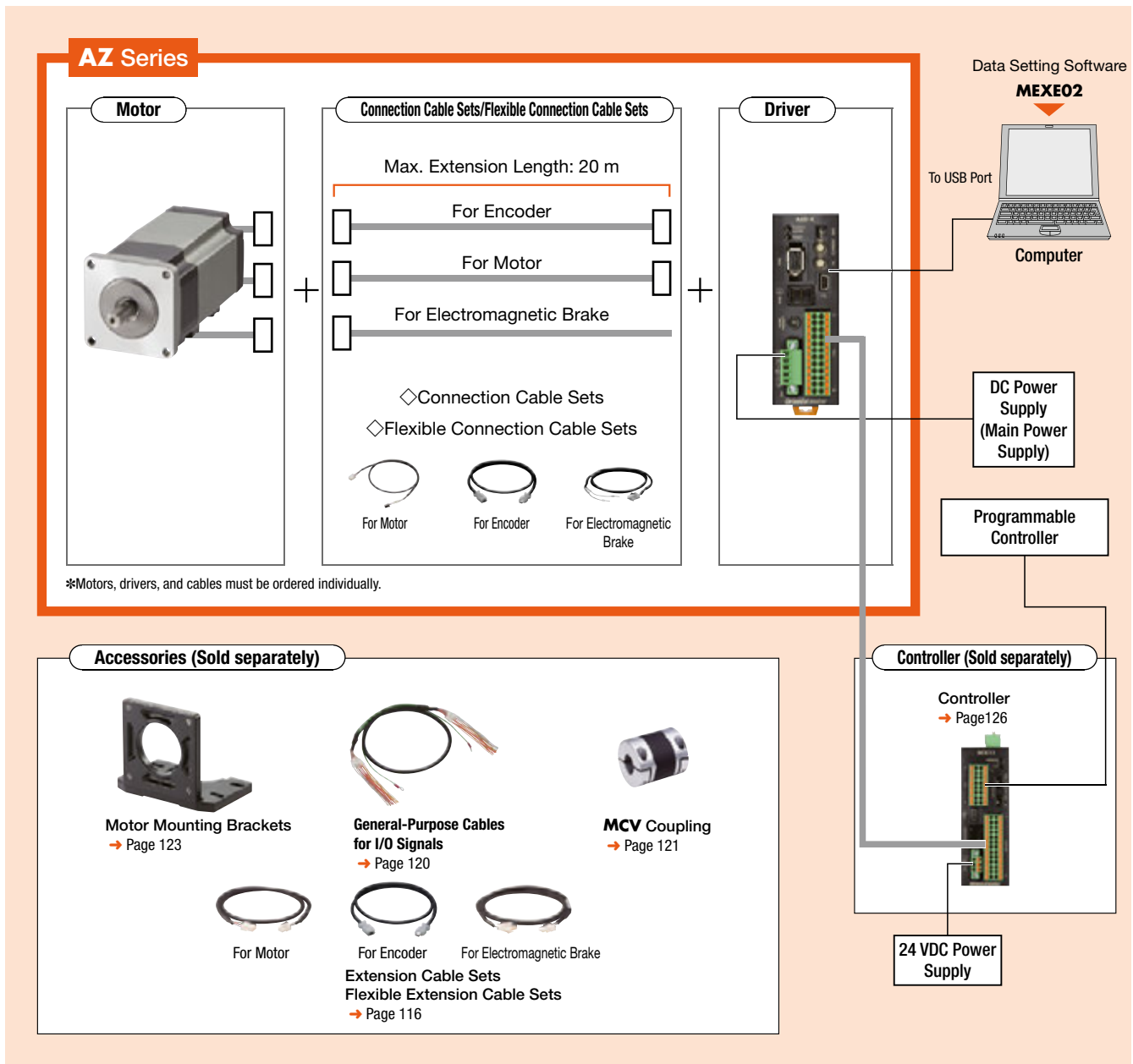

● **System Configuration Example**

| AZ Series      |              |                       | Accessory       |                         |                   |  |
|----------------|--------------|-----------------------|-----------------|-------------------------|-------------------|--|
| Motor          | Driver       | Connection Cable Sets | Sold Separately |                         |                   |  |
| <b>AZM66MK</b> | <b>AZD-K</b> | <b>CC030VZFB2</b>     | Controller      | Motor Mounting Brackets | Flexible Coupling | General-Purpose Cables for I/O Signals (1 m) |
| €447.00        | €310.00      | €63.00                | <b>SCX11</b>    | <b>PAL2P-5</b>          | <b>MCV251010</b>  | <b>CC16D010B-1</b>                           |
|                |              |                       | €215.00         | €13.00                  | €53.00            | €21.00                                       |

● The system configuration shown above is an example. Other combinations are also available.

**Note**

● The motor cable and electromagnetic brake cable from the motor cannot be connected directly to the driver. When connecting to a driver, use a connection cable.

## Product Number Code

### Motor

#### ◇ Standard Type

**AZM 6 6 A 0 K**

① ② ③ ④ ⑤ ⑥

#### ◇ PS, HPG, Harmonic Geared Type

**AZM 6 6 A K - HP 15 F**

① ② ③ ④ ⑥ ⑦ ⑧ ⑨

#### ◇ TS Geared Type

**AZM 6 6 A K - TS 10 U**

① ② ③ ④ ⑤ ⑥ ⑦ ⑧

#### ◇ FC Geared Type

**AZM 6 6 A K - FC 10 U A**

① ② ③ ④ ⑤ ⑥ ⑦ ⑧ ⑨

### Driver

**AZD - K D**

① ② ③

### Connection Cable Sets/Flexible Connection Cable Sets

**CC 050 V Z □ F B 2**

① ② ③ ④ ⑤ ⑥ ⑦ ⑧

|   |                     |   |
|---|---------------------|---|
| ① | Motor Type          | <b>AZM: AZ</b> Series Motor   |
| ② | Motor Frame Size    | <b>1:</b> 20 mm<br><b>2:</b> 28 mm<br><b>4:</b> 42 mm ( <b>HPG</b> Geared Type is 40 mm)<br><b>6:</b> 60 mm             |
|   | Motor Case Length   |   |
|   | Configuration       | <b>A:</b> Single Shaft <b>M:</b> With Electromagnetic Brake   |
| ⑤ | Shaft Shape         | <b>0:</b> Straight Type <b>1:</b> With Key  |
| ⑥ | Motor Specification | <b>K:</b> DC Power Supply Input   |
| ⑦ | Geared Type         | <b>TS: TS</b> Geared Type<br><b>PS: PS</b> Geared Type<br><b>HP: HPG</b> Geared Type<br><b>HS:</b> Harmonic Geared Type |
|   | Gear Ratio          |   |
|   | Output Shaft Type   | <b>HPG</b> Geared Type<br>Blank: Shaft Output <b>F:</b> Flange Output   |
|   |                     |   |

\*For standard types without specified shaft shape one shaft side is milled.

|   |                     |   |
|---|---------------------|---|
| ① | Motor Type          | <b>AZM: AZ</b> Series Motor                                 |
| ② | Motor Frame Size    | <b>4:</b> 42 mm<br><b>6:</b> 60 mm                          |
|   | Motor Case Length   |   |
| ④ | Configuration       | <b>A:</b> Single Shaft <b>M:</b> With Electromagnetic Brake |
| ⑤ | Motor Specification | <b>K:</b> DC Power Supply Input                             |
| ⑥ | Geared Type         | <b>TS: TS</b> Geared Type                                   |
| ⑦ | Gear Ratio          |   |
| ⑧ | Cable Direction     | <b>U:</b> Up <b>L:</b> Left <b>R:</b> Right                 |

|   |                     |   |
|---|---------------------|---|
| ① | Motor Type          | <b>AZM: AZ</b> Series Motor                                 |
| ② | Motor Frame Size    | <b>4:</b> 42 mm<br><b>6:</b> 60 mm                          |
|   | Motor Case Length   |   |
| ④ | Configuration       | <b>A:</b> Single Shaft <b>M:</b> With Electromagnetic Brake |
| ⑤ | Motor Specification | <b>K:</b> DC Power Supply Input                             |
| ⑥ | Geared Type         | <b>FC: FC</b> Geared Type                                   |
| ⑦ | Gear Ratio          |   |
| ⑧ | Cable Direction     | <b>D:</b> Down <b>U:</b> Up                                 |
| ⑨ | Identification      | <b>A:</b> Solid shaft                                       |

\*With the output shaft pointing to the left the cable direction is defined by looking from the gearhead side.

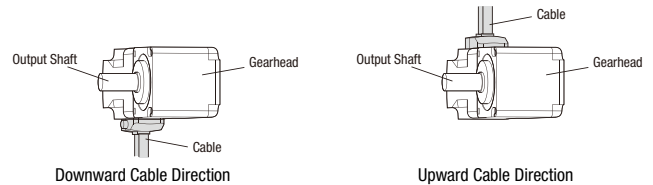

|   |                    |   |
|---|--------------------|---|
| ① | Driver Type        | <b>AZD: AZ</b> Series Driver  |
| ② | Power Supply Input | <b>K:</b> 24/48 VDC   |
| ③ | Type               | <b>D:</b> Built-in Controller Type<br><b>X:</b> Pulse-Input Type with RS-485 Communication<br>Blank: Pulse Input Type |
|   |                    |   |
|   |                    |   |

|   |                       |  |
|---|-----------------------|--|
| ① |                       | <b>CC:</b> Cable   |
| ② | Length                | <b>005:</b> 0.5 m <b>010:</b> 1 m <b>015:</b> 1.5 m <b>020:</b> 2 m<br><b>025:</b> 2.5 m <b>030:</b> 3 m <b>040:</b> 4 m <b>050:</b> 5 m<br><b>070:</b> 7 m <b>100:</b> 10 m <b>150:</b> 15 m <b>200:</b> 20 m |
|   | Reference Number      |  |
|   | Applicable Models     | <b>Z: AZ</b> Series  |
| ⑤ | Reference Number      | Blank: Frame Size 42 mm ( <b>HPG</b> Geared Type is 40 mm),<br>60 mm<br><b>2:</b> Frame Size 20 mm, 28 mm  |
|   | Cable Type            | <b>F:</b> Connection Cable Sets<br><b>R:</b> Flexible Connection Cable Sets  |
| ⑦ | Electromagnetic Brake | Blank: Without Electromagnetic Brake<br><b>B:</b> With Electromagnetic Brake   |
|   | Cable Specifications  | <b>2:</b> DC Power Supply Input  |

## Product Line

### Motor

#### Standard Type



| Frame Size | Product Name    | List Price |
|------------|-----------------|------------|
| 20 mm      | <b>AZM14AK</b>  | €230.00    |
|            | <b>AZM15AK</b>  |            |
| 28 mm      | <b>AZM24AK</b>  | €230.00    |
|            | <b>AZM26AK</b>  |            |
|            | <b>AZM46AK</b>  |            |
| 42 mm      | <b>AZM46A0K</b> | €246.00    |
|            | <b>AZM48AK</b>  |            |
|            | <b>AZM48A0K</b> | €255.00    |
|            | <b>AZM48A1K</b> |            |
|            | <b>AZM66AK</b>  | €290.00    |
|            | <b>AZM66A0K</b> |            |
| 60 mm      | <b>AZM66A1K</b> | €290.00    |
|            | <b>AZM69AK</b>  |            |
|            | <b>AZM69A0K</b> | €295.00    |
|            | <b>AZM69A1K</b> |            |

#### Standard Type with Electromagnetic Brake



| Frame Size      | Product Name    | List Price |
|-----------------|-----------------|------------|
| 42 mm           | <b>AZM46MK</b>  | €368.00    |
|                 | <b>AZM46M0K</b> |            |
| 60 mm           | <b>AZM66MK</b>  | €447.00    |
|                 | <b>AZM66M0K</b> |            |
|                 | <b>AZM66M1K</b> | €447.00    |
|                 | <b>AZM69MK</b>  | €452.00    |
|                 | <b>AZM69M0K</b> |            |
| <b>AZM69M1K</b> | €460.00         |            |

#### TS Geared Type



| Frame Size | Product Name         | Gear Ratio | List Price |
|------------|----------------------|------------|------------|
| 42 mm      | <b>AZM46AK-TS□UA</b> | 3.6, 7.2   | €341.00    |
|            | <b>AZM46AK-TS□UA</b> | 10, 20, 30 | €351.00    |
|            | <b>AZM66AK-TS□UA</b> | 3.6, 7.2   | €400.00    |
| 60 mm      | <b>AZM66AK-TS□UA</b> | 10, 20, 30 | €410.00    |

#### TS Geared Type with Electromagnetic Brake



| Frame Size | Product Name         | Gear Ratio | List Price |
|------------|----------------------|------------|------------|
| 42 mm      | <b>AZM46MK-TS□UA</b> | 3.6, 7.2   | €463.00    |
|            | <b>AZM46MK-TS□UA</b> | 10, 20, 30 | €473.00    |
|            | <b>AZM66MK-TS□UA</b> | 3.6, 7.2   | €557.00    |
| 60 mm      | <b>AZM66MK-TS□UA</b> | 10, 20, 30 | €567.00    |

#### FC Geared Type



| Frame Size | Product Name         | Gear Ratio      | List Price |
|------------|----------------------|-----------------|------------|
| 42 mm      | <b>AZM46AK-FC□UA</b> | 7.2, 10, 20, 30 | €451.00    |
|            | <b>AZM46AK-FC□DA</b> |                 |            |
| 60 mm      | <b>AZM66AK-FC□UA</b> | 7.2, 10, 20, 30 | €510.00    |
|            | <b>AZM66AK-FC□DA</b> |                 |            |

#### FC Geared Type with Electromagnetic Brake



| Frame Size | Product Name         | Gear Ratio      | List Price |
|------------|----------------------|-----------------|------------|
| 42 mm      | <b>AZM46MK-FC□UA</b> | 7.2, 10, 20, 30 | €573.00    |
|            | <b>AZM46MK-FC□DA</b> |                 |            |
| 60 mm      | <b>AZM66MK-FC□UA</b> | 7.2, 10, 20, 30 | €667.00    |
|            | <b>AZM66MK-FC□DA</b> |                 |            |

#### PS Geared Type



| Frame Size | Product Name       | Gear Ratio | List Price |
|------------|--------------------|------------|------------|
| 42 mm      | <b>AZM46AK-PS□</b> | 5, 7.2, 10 | €413.00    |
|            | <b>AZM46AK-PS□</b> | 25, 36, 50 | €450.00    |
| 60 mm      | <b>AZM66AK-PS□</b> | 5, 7.2, 10 | €494.00    |
|            | <b>AZM66AK-PS□</b> | 25, 36, 50 | €546.00    |

#### PS Geared Type with Electromagnetic Brake



| Frame Size | Product Name       | Gear Ratio | List Price |
|------------|--------------------|------------|------------|
| 42 mm      | <b>AZM46MK-PS□</b> | 5, 7.2, 10 | €535.00    |
|            | <b>AZM46MK-PS□</b> | 25, 36, 50 | €572.00    |
| 60 mm      | <b>AZM66MK-PS□</b> | 5, 7.2, 10 | €651.00    |
|            | <b>AZM66MK-PS□</b> | 25, 36, 50 | €703.00    |

● A number indicating the gear ratio is entered where the box □ is located in the product name.  
 ● Either **R** (right), **L** (left) or **U** (up) is entered for the cable withdrawing direction in ◇ in the product name.



◇ **HPG Geared Type**

| Frame Size | Product Name         | List Price |
|------------|----------------------|------------|
| 40 mm      | <b>AZM46AK-HP5</b>   | €526.00    |
|            | <b>AZM46AK-HP5F</b>  | €516.00    |
|            | <b>AZM46AK-HP9</b>   | €526.00    |
|            | <b>AZM46AK-HP9F</b>  | €516.00    |
| 60 mm      | <b>AZM66AK-HP5</b>   | €710.00    |
|            | <b>AZM66AK-HP5F</b>  | €695.00    |
|            | <b>AZM66AK-HP15</b>  | €835.00    |
|            | <b>AZM66AK-HP15F</b> | €820.00    |



◇ **HPG Geared Type with Electromagnetic Brake**

| Frame Size | Product Name         | List Price |
|------------|----------------------|------------|
| 40 mm      | <b>AZM46MK-HP5</b>   | €648.00    |
|            | <b>AZM46MK-HP5F</b>  | €638.00    |
|            | <b>AZM46MK-HP9</b>   | €648.00    |
|            | <b>AZM46MK-HP9F</b>  | €638.00    |
|            | <b>AZM46MK-HP9F</b>  | €638.00    |
| 60 mm      | <b>AZM66MK-HP5</b>   | €867.00    |
|            | <b>AZM66MK-HP5F</b>  | €852.00    |
|            | <b>AZM66MK-HP15</b>  | €992.00    |
|            | <b>AZM66MK-HP15F</b> | €977.00    |



◇ **Harmonic Geared Type**

| Frame Size | Product Name        | Gear Ratio | List Price |
|------------|---------------------|------------|------------|
| 42 mm      | <b>AZM46AK-HS</b> □ | 50, 100    | €701.00    |
| 60 mm      | <b>AZM66AK-HS</b> □ |            | €945.00    |



◇ **Harmonic Geared Type with Electromagnetic Brake**

| Frame Size | Product Name        | Gear Ratio | List Price |
|------------|---------------------|------------|------------|
| 42 mm      | <b>AZM46MK-HS</b> □ | 50, 100    | €823.00    |
| 60 mm      | <b>AZM66MK-HS</b> □ |            | €1,102.00  |

● **Driver**

◇ **Built-in Controller Type**

| Power Supply Input | Product Name  | List Price |
|--------------------|---------------|------------|
| 24/48 VDC          | <b>AZD-KD</b> | €360.00    |



◇ **Pulse-Input Type with RS-485 Communication**

| Power Supply Input | Product Name  | List Price |
|--------------------|---------------|------------|
| 24/48 VDC          | <b>AZD-KX</b> | €360.00    |



◇ **Pulse Input Type**

| Power supply input | Product Name | List Price |
|--------------------|--------------|------------|
| 24/48 VDC          | <b>AZD-K</b> | €310.00    |



## ● Connection Cable Sets/Flexible Connection Cable Sets

Use the flexible connection cable in applications where the cable is bent and flexed repeatedly. To extend the connection cables extension cables and flexible extension cables are provided. Please see page 116-117.

The motor cable and electromagnetic brake cable from the motor cannot be connected directly to the driver. Use a connection cable to connect the driver.

[For **AZM14, AZM15, AZM24, AZM26**]



### ◇ Without Electromagnetic Brake

| Product Line          | Length L (m)      | Product Name      | List Price |
|-----------------------|-------------------|-------------------|------------|
| Connection Cable Sets | 0.5               | <b>CC005VZ2F2</b> | €29.00     |
|                       | 1                 | <b>CC010VZ2F2</b> | €29.00     |
|                       | 1.5               | <b>CC015VZ2F2</b> | €33.00     |
|                       | 2                 | <b>CC020VZ2F2</b> | €38.00     |
|                       | 2.5               | <b>CC025VZ2F2</b> | €43.00     |
|                       | 3                 | <b>CC030VZ2F2</b> | €48.00     |
|                       | 4                 | <b>CC040VZ2F2</b> | €75.00     |
|                       | 5                 | <b>CC050VZ2F2</b> | €84.00     |
|                       | 7                 | <b>CC070VZ2F2</b> | €104.00    |
|                       | 10                | <b>CC100VZ2F2</b> | €135.00    |
| 15                    | <b>CC150VZ2F2</b> | €187.00           |            |
| 20                    | <b>CC200VZ2F2</b> | €237.00           |            |

| Product Line                   | Length L (m)      | Product Name      | List Price |
|--------------------------------|-------------------|-------------------|------------|
| Flexible Connection Cable Sets | 0.5               | <b>CC005VZ2R2</b> | €65.00     |
|                                | 1                 | <b>CC010VZ2R2</b> | €65.00     |
|                                | 1.5               | <b>CC015VZ2R2</b> | €70.00     |
|                                | 2                 | <b>CC020VZ2R2</b> | €76.00     |
|                                | 2.5               | <b>CC025VZ2R2</b> | €76.00     |
|                                | 3                 | <b>CC030VZ2R2</b> | €85.00     |
|                                | 4                 | <b>CC040VZ2R2</b> | €85.00     |
|                                | 5                 | <b>CC050VZ2R2</b> | €108.00    |
|                                | 7                 | <b>CC070VZ2R2</b> | €138.00    |
|                                | 10                | <b>CC100VZ2R2</b> | €181.00    |
| 15                             | <b>CC150VZ2R2</b> | €254.00           |            |
| 20                             | <b>CC200VZ2R2</b> | €326.00           |            |

[For **AZM46, AZM66, AZM69**]



### ◇ Without Electromagnetic Brake

| Product Line                   | Length L (m)     | Product Name     | List Price |
|--------------------------------|------------------|------------------|------------|
| Connection Cable Sets          | 0.5              | <b>CC005VZF2</b> | €29.00     |
|                                | 1                | <b>CC010VZF2</b> | €29.00     |
|                                | 1.5              | <b>CC015VZF2</b> | €33.00     |
|                                | 2                | <b>CC020VZF2</b> | €38.00     |
|                                | 2.5              | <b>CC025VZF2</b> | €43.00     |
|                                | 3                | <b>CC030VZF2</b> | €48.00     |
|                                | 4                | <b>CC040VZF2</b> | €75.00     |
|                                | 5                | <b>CC050VZF2</b> | €84.00     |
|                                | 7                | <b>CC070VZF2</b> | €104.00    |
|                                | 10               | <b>CC100VZF2</b> | €135.00    |
| 15                             | <b>CC150VZF2</b> | €187.00          |            |
| 20                             | <b>CC200VZF2</b> | €237.00          |            |
| Flexible Connection Cable Sets | 0.5              | <b>CC005VZR2</b> | €65.00     |
|                                | 1                | <b>CC010VZR2</b> | €65.00     |
|                                | 1.5              | <b>CC015VZR2</b> | €70.00     |
|                                | 2                | <b>CC020VZR2</b> | €76.00     |
|                                | 2.5              | <b>CC025VZR2</b> | €80.00     |
|                                | 3                | <b>CC030VZR2</b> | €85.00     |
|                                | 4                | <b>CC040VZR2</b> | €97.00     |
|                                | 5                | <b>CC050VZR2</b> | €108.00    |
|                                | 7                | <b>CC070VZR2</b> | €137.00    |
|                                | 10               | <b>CC100VZR2</b> | €181.00    |
| 15                             | <b>CC150VZR2</b> | €262.00          |            |
| 20                             | <b>CC200VZR2</b> | €326.00          |            |



| Product Line                   | Length L (m)      | Product Name      | List Price |
|--------------------------------|-------------------|-------------------|------------|
| Connection Cable Sets          | 0.5               | <b>CC005VZFB2</b> | €40.00     |
|                                | 1                 | <b>CC010VZFB2</b> | €40.00     |
|                                | 1.5               | <b>CC015VZFB2</b> | €46.00     |
|                                | 2                 | <b>CC020VZFB2</b> | €52.00     |
|                                | 2.5               | <b>CC025VZFB2</b> | €57.00     |
|                                | 3                 | <b>CC030VZFB2</b> | €63.00     |
|                                | 4                 | <b>CC040VZFB2</b> | €93.00     |
|                                | 5                 | <b>CC050VZFB2</b> | €103.00    |
|                                | 7                 | <b>CC070VZFB2</b> | €127.00    |
|                                | 10                | <b>CC100VZFB2</b> | €163.00    |
| 15                             | <b>CC150VZFB2</b> | €225.00           |            |
| 20                             | <b>CC200VZFB2</b> | €285.00           |            |
| Flexible Connection Cable Sets | 0.5               | <b>CC005VZRB2</b> | €87.00     |
|                                | 1                 | <b>CC010VZRB2</b> | €87.00     |
|                                | 1.5               | <b>CC015VZRB2</b> | €95.00     |
|                                | 2                 | <b>CC020VZRB2</b> | €103.00    |
|                                | 2.5               | <b>CC025VZRB2</b> | €109.00    |
|                                | 3                 | <b>CC030VZRB2</b> | €115.00    |
|                                | 4                 | <b>CC040VZRB2</b> | €131.00    |
|                                | 5                 | <b>CC050VZRB2</b> | €146.00    |
|                                | 7                 | <b>CC070VZRB2</b> | €184.00    |
|                                | 10                | <b>CC100VZRB2</b> | €237.00    |
| 15                             | <b>CC150VZRB2</b> | €331.00           |            |
| 20                             | <b>CC200VZRB2</b> | €422.00           |            |

## ■ Included

### ● Motor

| Type              | Included         | Parallel Key | Motor Installation Screw | Operating Manual |
|-------------------|------------------|--------------|--------------------------|------------------|
| Standard          | —                | —            | —                        | 1 Copy           |
| <b>TS</b> Geared  | Frame Size 42 mm | —            | —                        |                  |
|                   | Frame Size 60 mm | 1 Piece      | M4×60 P0.7 (4 Screws)    |                  |
| <b>FC</b> Geared  | —                | 1 Piece      | —                        |                  |
| <b>PS</b> Geared  | —                | 1 Piece      | —                        |                  |
| <b>HPG</b> Geared | Shaft Output     | 1 Piece      | —                        |                  |
|                   | Flange Output    | —            | —                        |                  |
| Harmonic Geared   | —                | 1 Piece      | —                        |                  |

### ● Driver

| Type   | Included | Connector  | Operating Manual |
|--|----------|--|------------------|
| Built-in Controller Type<br>Pulse Input Type | —        | • Connector for CN4 (1 Piece)<br>• Connector for CN1 (1 Piece) | 1 Copy           |

### ● Connection Cable Sets / Flexible Connection Cable Sets

| Type                           | Included | Operating Manual |
|--------------------------------|----------|------------------|
| Connection Cable Sets          | —        | —                |
| Flexible Connection Cable Sets | —        | 1 Copy           |

● For the functions and operation of the product please refer to the operating manual (function edition). The function edition is not included in the product, please contact the nearest sales office or download it from the website.

# Standard Type Frame Size 20 mm, 28 mm



## Specifications

| Motor Product Name                 | Single Shaft                               | AZM14AK              | AZM15AK              | AZM24AK              | AZM26AK             |
|------------------------------------|--|----------------------|----------------------|----------------------|---------------------|
| Driver Product Name                | Built-in Controller Type                   | AZD-KD               |                      |                      |                     |
|                                    | Pulse-Input Type with RS-485 Communication | AZD-KX               |                      |                      |                     |
|                                    | Pulse Input Type                           | AZD-K                |                      |                      |                     |
| Maximum Holding Torque             | N·m  | 0.02                 | 0.036                | 0.095                | 0.19                |
| Holding Torque at Motor Standstill | N·m  | 0.01                 | 0.018                | 0.047                | 0.095               |
| Rotor Inertia                      | J: kg·m <sup>2</sup>                       | $2.7 \times 10^{-7}$ | $3.9 \times 10^{-7}$ | $9.2 \times 10^{-7}$ | $17 \times 10^{-7}$ |
| Resolution                         | Resolution Setting: 1000 P/R               | 0.36°/Pulse          |                      |                      |                     |
| Power Supply Input                 | Voltage                                    | 24 VDC ± 5%          |                      |                      |                     |
|                                    | Input Current                              | A                    | 0.5                  | 0.6                  | 1.6                 |

## Speed - Torque Characteristics (Reference Value)

**AZM14**

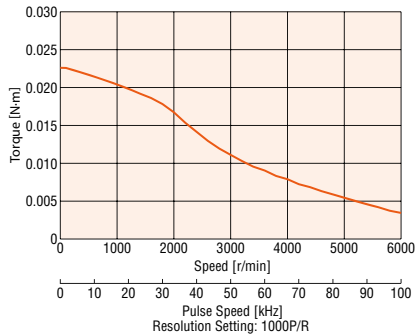

**AZM15**

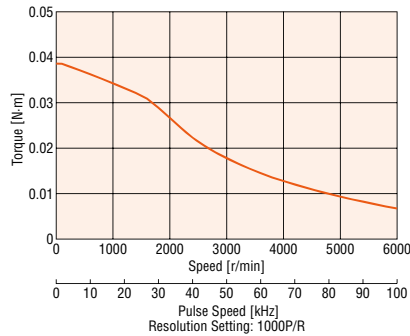

**AZM24**

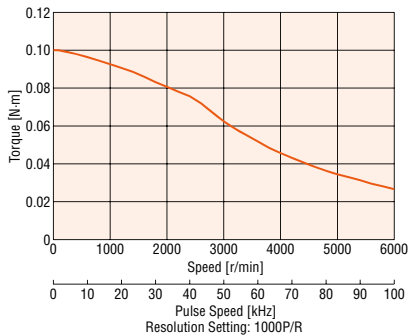

**AZM26**

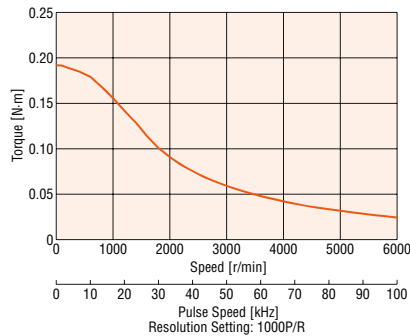

### Notes

- The speed-torque characteristics are data based upon our measurement conditions. When these conditions change, these characteristics may change.
- Depending on the driving conditions, a considerable amount of heat may be generated by the motor. Be sure to keep the motor case temperature at 80°C or less in order to protect the ABZO sensor.

## Explanation of Terms in Specifications Table

|                              |  |  |
|------------------------------|--|--|
| Maximum Holding Torque       | The maximum holding torque (holding force) the motor has when power (rated current) is being supplied but the motor shaft is at standstill. (With geared types, the value of holding torque considers the permissible strength of the gear.) |  |
| Permissible Torque           | This is the maximum torque continuously applied to the gear output shaft.  |  |
| Max. Instantaneous Torque    | This is the maximum torque that can be applied to the gear output shaft during acceleration/deceleration, such as when an inertial load is started and stopped.  |  |
| Holding Torque at Standstill | When Power is ON   | This is the holding torque when the automatic current cutback function is activated.   |
|                              | Electromagnetic Brake  | This is the static friction torque that the electromagnetic brake can generate at rest. (Electromagnetic brake is power off activated type.) |



# Standard Type Frame Size 42mm, 60 mm

## Specifications



|                                    |  |  |                      |  |  |              |
|------------------------------------|--|--|----------------------|--|--|--------------|
| Motor Product Name                 | Single Shaft                               | <b>AZM46A□K</b>                                  | <b>AZM48A□K</b>      | <b>AZM66A□K</b>                                    | <b>AZM69A□K</b>                                    |              |
|                                    | With Electromagnetic Brake                 | <b>AZM46M□K</b>                                  | —                    | <b>AZM66M□K</b>                                    | <b>AZM69M□K</b>                                    |              |
| Driver Product Name                | Built-in Controller Type                   | <b>AZD-KD</b>                                    |                      |  |  |              |
|                                    | Pulse-Input Type with RS-485 Communication | <b>AZD-KX</b>                                    |                      |  |  |              |
|                                    | Pulse Input Type                           | <b>AZD-K</b>                                     |                      |  |  |              |
| Maximum Holding Torque             | N·m  | 0.3  | 0.72                 | 1  | 2  |              |
| Holding Torque at Motor Standstill | Power ON                                   | N·m  | 0.15                 | 0.36   | 0.5  | 1            |
|                                    | Electromagnetic Brake                      | N·m  | 0.15                 | —  | 0.5  | 1            |
| Rotor Inertia                      | J: kg·m <sup>2</sup>                       | $55 \times 10^{-7}$<br>( $71 \times 10^{-7}$ )*1 | $115 \times 10^{-7}$ | $370 \times 10^{-7}$<br>( $530 \times 10^{-7}$ )*1 | $740 \times 10^{-7}$<br>( $900 \times 10^{-7}$ )*1 |              |
| Resolution                         | Resolution Setting: 1000 P/R               | 0.36°/Pulse                                      |                      |  |  |              |
| Power Supply Input                 | Voltage                                    | 24 VDC ± 5%*2 / 48 VDC ± 5%*3                    |                      |  |  |              |
|                                    | Input Current                              | A  | 1.72 (1.8)*1         | 2.2  | 3.55 (3.8)*1                                       | 3.45 (3.7)*1 |

● Either **0** (straight) or **1** (with key) indicating the shaft shape is entered where the box □ is located in the product name. (For **AZM46** straight only). For the one side milled shaft shape no number is specified.

\*1 The brackets ( ) indicate the specifications for the product with an electromagnetic brake.

\*2 For the type with an electromagnetic brake, a 24 VDC ± 4% specification applies if the wiring distance between the motor and driver is extended to 20 m using a cable.

\*3 When the motor is operated from 48 VDC input, as a reference, use an inertial load 10 times the rotor inertial ratio or less and twice the safety factor or more when calculating the acceleration torque (excluding **AZM46**).

\*4 Only for the Motor.

## Speed - Torque Characteristics (Reference Value)

**AZM46**

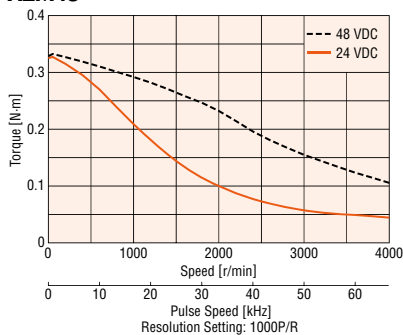

**AZM48**

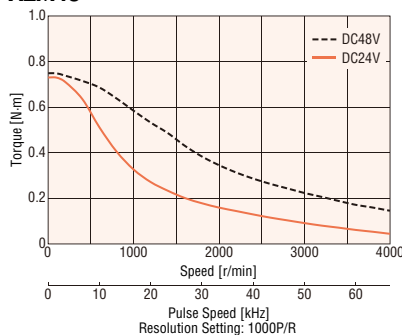

**AZM66**

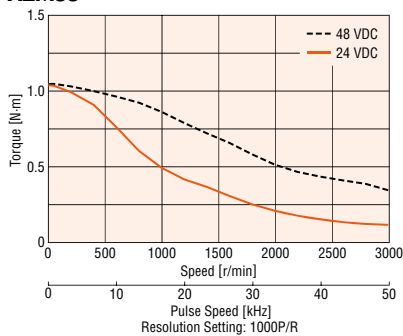

**AZM69**

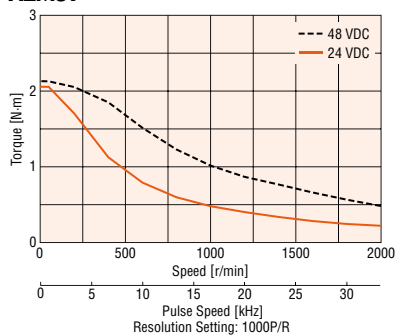

### Notes

● The speed-torque characteristics are data based upon our measurement conditions. When these conditions change, these characteristics may change.

● Depending on the driving conditions, a considerable amount of heat may be generated by the motor. Be sure to keep the motor case temperature at 80°C or less in order to protect the ABZO sensor. (When conforming to the UL standards, it is required to keep the temperature of the motor case at 75°C or less, since the motor is recognized as thermal class A.)

Features

System Configuration

Product Line

Specifications and Features

Dimensions

Connection and Operation

System Configuration

Product Line

Specifications and Features

Dimensions

Connection and Operation

Multiaxis Driver

Accessories

AC Input

DC Input

# TS Geared Type Frame Size 42mm

## Specifications



|                                    |  |   |   |  |  |  |     |
|------------------------------------|--|---|---|--|--|--|-----|
| Motor Product Name                 | Single Shaft                               | <b>AZM46AK-TS3.6</b> <input type="checkbox"/> | <b>AZM46AK-TS7.2</b> <input type="checkbox"/> | <b>AZM46AK-TS10</b> <input type="checkbox"/> | <b>AZM46AK-TS20</b> <input type="checkbox"/> | <b>AZM46AK-TS30</b> <input type="checkbox"/> |     |
|                                    | With Electromagnetic Brake                 | <b>AZM46MK-TS3.6</b> <input type="checkbox"/> | <b>AZM46MK-TS7.2</b> <input type="checkbox"/> | <b>AZM46MK-TS10</b> <input type="checkbox"/> | <b>AZM46MK-TS20</b> <input type="checkbox"/> | <b>AZM46MK-TS30</b> <input type="checkbox"/> |     |
| Driver Product Name                | Built-in Controller Type                   | <b>AZD-KD</b>                                 |   |  |  |  |     |
|                                    | Pulse Input Type with RS-485 Communication | <b>AZD-KX</b>                                 |   |  |  |  |     |
|                                    | Pulse Input Type                           | <b>AZD-K</b>                                  |   |  |  |  |     |
| Maximum Holding Torque             | N·m  | 0.65  | 1.2   | 1.7  | 2  | 2.3  |     |
| Rotor Inertia                      | J: kg·m <sup>2</sup>                       | 55×10 <sup>-7</sup> (71×10 <sup>-7</sup> )*1  |   |  |  |  |     |
| Gear Ratio                         |  | 3.6   | 7.2   | 10   | 20   | 30   |     |
| Resolution                         | Resolution Setting: 1000P/R                | 0.1°/Pulse                                    | 0.05°/Pulse                                   | 0.036°/Pulse                                 | 0.018°/Pulse                                 | 0.012°/Pulse                                 |     |
| Permissible Torque                 | N·m  | 0.65  | 1.2   | 1.7  | 2  | 2.3  |     |
| Max. Instantaneous Torque*         | N·m  | 0.85  | 1.6   | 2  | *  | 3  |     |
| Holding Torque at Motor Standstill | Power ON                                   | N·m   | 0.54  | 1  | 1.5  | 1.8  | 2.3 |
|                                    | Electromagnetic Brake                      | N·m   | 0.54  | 1  | 1.5  | 1.8  | 2.3 |
| Speed Range                        | r/min                                      | 0~833   | 0~416   | 0~300  | 0~150  | 0~100  |     |
| Backlash                           | arcmin                                     | 45 (0.75)                                     | 25 (0.42)                                     |  | 15 (0.25)                                    |  |     |
| Power Supply Input                 | Voltage                                    | 24 VDC±5%*2/48 VDC±5%                         |   |  |  |  |     |
|                                    | Input Current                              | 1.72 (1.8)*1                                  |   |  |  |  |     |

\*For the geared motor output torque, refer to the speed – torque characteristics.

● Either **R** (right), **U** (up) or **L** (left) indicating the cable withdrawing direction is entered where the box  is located within the product name. For the downward direction no letter is entered in the box .

\*1 The brackets ( ) indicate the specifications for the product with an electromagnetic brake.

\*2 For the type with an electromagnetic brake, a 24 VDC±4% specification applies if the wiring distance between the motor and driver is extended to 20 m using a cable.

\*3 Only for the Motor.

## Speed - Torque Characteristics (Reference Value)

**AZM46 Gear Ratio 3.6**

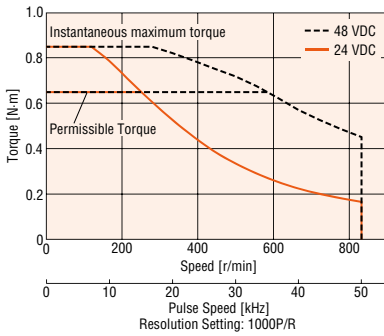

**AZM46 Gear Ratio 7.2**

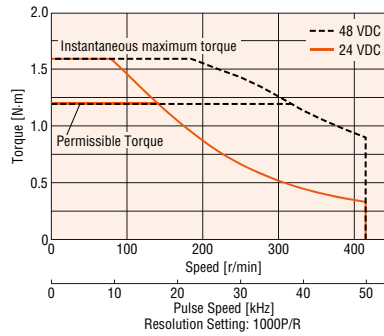

**AZM46 Gear Ratio 10**

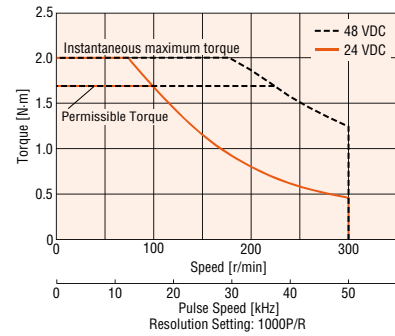

**AZM46 Gear Ratio 20**

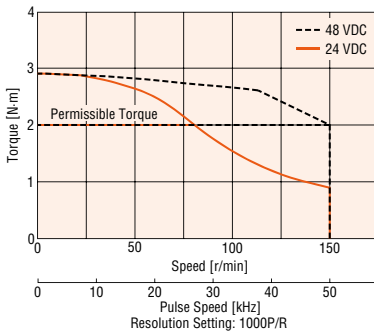

**AZM46 Gear Ratio 30**

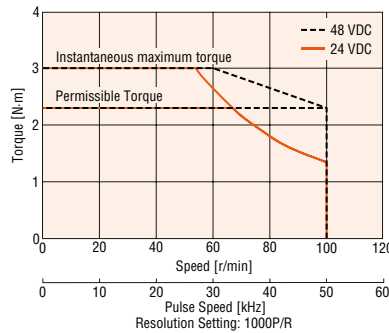

### Notes

- The speed-torque characteristics are data based upon our measurement conditions. When these conditions change, these characteristics may change.
- Depending on the driving conditions, a considerable amount of heat may be generated by the motor. Be sure to keep the motor case temperature at 80°C or less in order to protect the ABZO sensor. (When conforming to the UL standards, it is required to keep the temperature of the motor case at 75°C or less, since the motor is recognized as thermal class A.)

# TS Geared Type Frame Size 60 mm

## Specifications



| Motor Product Name                 | Single Shaft                               | <input type="checkbox"/> AZM66AK-TS3.6         | <input type="checkbox"/> AZM66AK-TS7.2 | <input type="checkbox"/> AZM66AK-TS10 | <input type="checkbox"/> AZM66AK-TS20 | <input type="checkbox"/> AZM66AK-TS30 |   |
|------------------------------------|--|--|--|---------------------------------------|---------------------------------------|---------------------------------------|---|
|                                    | With Electromagnetic Brake                 | <input type="checkbox"/> AZM66MK-TS3.6         | <input type="checkbox"/> AZM66MK-TS7.2 | <input type="checkbox"/> AZM66MK-TS10 | <input type="checkbox"/> AZM66MK-TS20 | <input type="checkbox"/> AZM66MK-TS30 |   |
| Driver Product Name                | Built-in Controller Type                   | AZD-KD   |  |                                       |                                       |                                       |   |
|                                    | Pulse-Input Type with RS-485 Communication | AZD-KX   |  |                                       |                                       |                                       |   |
|                                    | Pulse Input Type                           | AZD-K  |  |                                       |                                       |                                       |   |
| Maximum Holding Torque             | N·m  | 1.8  | 3                                      | 4                                     | 5                                     | 6                                     |   |
| Rotor Inertia                      | J: kg·m <sup>2</sup>                       | 370×10 <sup>-7</sup> (530×10 <sup>-7</sup> )*1 |  |                                       |                                       |                                       |   |
| Gear Ratio                         |  | 3.6  | 7.2                                    | 10                                    | 20                                    | 30                                    |   |
| Resolution                         | Resolution Setting: 1000P/R                | 0.1°/Pulse                                     | 0.05°/Pulse                            | 0.036°/Pulse                          | 0.018°/Pulse                          | 0.012°/Pulse                          |   |
| Permissible Torque                 | N·m  | 1.8  | 3                                      | 4                                     | 5                                     | 6                                     |   |
| Max. Instantaneous Torque*         | N·m  | *  | *                                      | *                                     | 8                                     | 10                                    |   |
| Holding Torque at Motor Standstill | Power ON                                   | N·m  | 1.1                                    | 2.2                                   | 3                                     | 5                                     | 6 |
|                                    | Electromagnetic Brake                      | N·m  | 1.1                                    | 2.2                                   | 3                                     | 5                                     | 6 |
| Speed Range                        | r/min                                      | 0~833  | 0~416                                  | 0~300                                 | 0~150                                 | 0~100                                 |   |
| Backlash                           | arcmin                                     | 35 (0.59)                                      | 15 (0.25)                              |                                       | 10 (0.17)                             |                                       |   |
| Power Supply Input                 | Voltage                                    | 24 VDC±5%*2/48 VDC±5%*3                        |  |                                       |                                       |                                       |   |
|                                    | Input Current                              | A  |  |                                       |                                       |                                       |   |
|                                    |  | 3.55 (3.8)*1                                   |  |                                       |                                       |                                       |   |

\*For the geared motor output torque, refer to the speed – torque characteristics.

● Either **R** (right), **U** (up) or **L** (left) indicating the cable withdrawing direction is entered where the box  is located within the product name. For the downward direction no letter is entered in the box .

\*1 The brackets ( ) indicate the specifications for the product with an electromagnetic brake.

\*2 For the type with an electromagnetic brake, a 24 VDC±4% specification applies if the wiring distance between the motor and driver is extended to 20 m using a cable.

\*3 When operating with 48 VDC input, set inertia load to approximately 10 times or less that of the rotor inertia ratio, and twice that of the safety rate when calculating accelerator torque.

\*4 Only for the Motor.

## Speed - Torque Characteristics (Reference Value)

**AZM66 Gear Ratio 3.6**

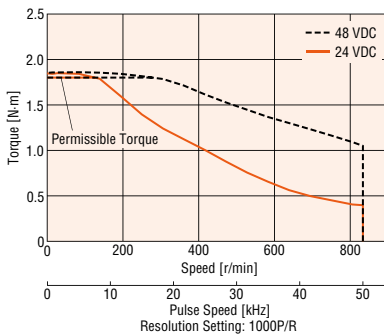

**AZM66 Gear Ratio 7.2**

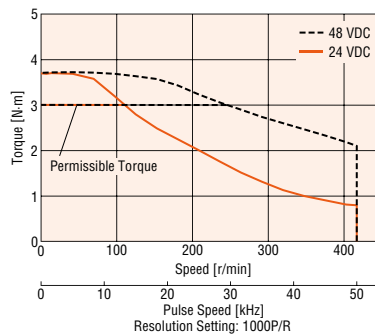

**AZM66 Gear Ratio 10**

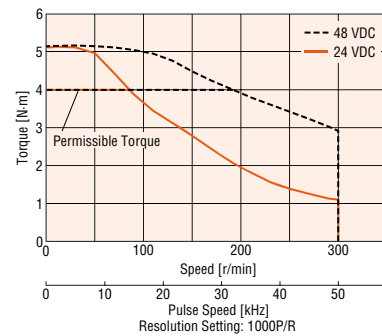

**AZM66 Gear Ratio 20**

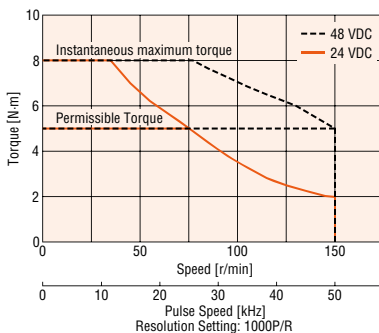

**AZM66 Gear Ratio 30**

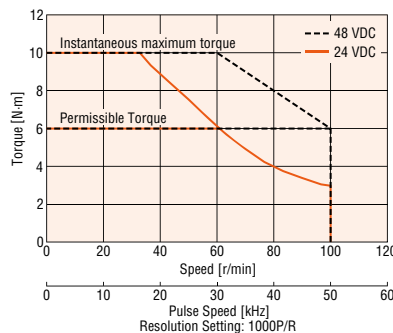

### Notes

● The speed-torque characteristics are data based upon our measurement conditions. When these conditions change, these characteristics may change.

● Depending on the driving conditions, a considerable amount of heat may be generated by the motor. Be sure to keep the motor case temperature at 80°C or less in order to protect the ABZO sensor. (When conforming to the UL standards, it is required to keep the temperature of the motor case at 75°C or less, since the motor is recognized as thermal class A.)

Features  
 System Configuration  
 Product Line  
 Specifications and Features  
 Dimensions  
 Connection and Operation  
 System Configuration  
 Product Line  
 Specifications and Features  
 DC Input  
 Dimensions  
 Connection and Operation  
 MultiAxis Driver  
 Accessories

# FC Geared Type Frame Size 42 mm

## Specifications



| Motor Product Name                          | Single Shaft                               | AZM46AK-FC7.2□A                              | AZM46AK-FC10□A | AZM46AK-FC20□A | AZM46AK-FC30□A |
|---|--|--|----------------|----------------|----------------|
| With Electromagnetic Brake                  |  | AZM46MK-FC7.2□A                              | AZM46MK-FC10□A | AZM46MK-FC20□A | AZM46MK-FC30□A |
| Driver Product Name                         | Built-in Controller Type                   | AZD-KD                                       |                |                |                |
|   | Pulse Input Type with RS-485 Communication | AZD-KX                                       |                |                |                |
|   | Pulse Input Type                           | AZD-K  |                |                |                |
| Maximum Holding Torque                      | N·m  | 0.7  | 1              | 2              | 3              |
| Rotor Inertia                               | J: kg·m <sup>2</sup>                       | 55×10 <sup>-7</sup> (71×10 <sup>-7</sup> )*1 |                |                |                |
| Gear Ratio                                  |  | 7.2  | 10             | 20             | 30             |
| Resolution                                  | Resolution Setting: 1000P/R                | 0.05°/Pulse                                  | 0.036°/Pulse   | 0.018°/Pulse   | 0.012°/Pulse   |
| Permissible Torque                          | N·m  | 0.7  | 1              | 2              | 3              |
| Holding Torque at Power ON                  | N·m  | 0.7  | 1              | 2              | 3              |
| Motor Standstill With Electromagnetic Brake | N·m  | 0.7  | 1              | 2              | 3              |
| Speed Range                                 | r/min                                      | 0~416  | 0~300          | 0~150          | 0~100          |
| Backlash                                    | arcmin                                     | 25 (0.42°)                                   |                | 15 (0.25°)     |                |
| Power Supply Input Voltage                  |  | 24 VDC±5%*2/48 VDC±5%                        |                |                |                |
| Power Supply Input Input Current            | A  | 1.72 (1.8)*1                                 |                |                |                |

● Either **U** (up) or **D** (down) indicating the cable withdrawing direction is entered where the box □ is located within the product name.

\*1 The brackets ( ) indicate the specifications for the product with an electromagnetic brake.

\*2 For the type with an electromagnetic brake, a 24 VDC±4% specification applies if the wiring distance between the motor and driver is extended to 20 m using a cable.

\*3 Only for the Motor.

## Speed - Torque Characteristics (Reference Value)

**AZM46 Gear Ratio 7.2**

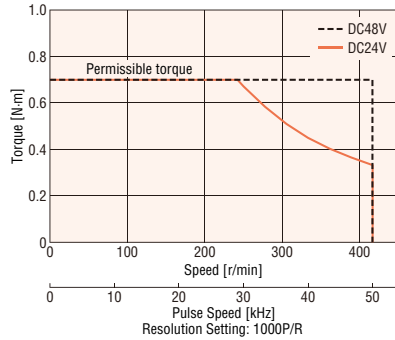

**AZM46 Gear Ratio 10**

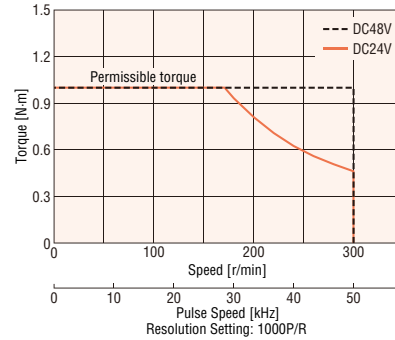

**AZM46 Gear Ratio 20**

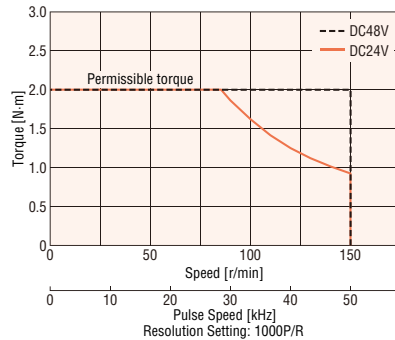

**AZM46 Gear Ratio 30**

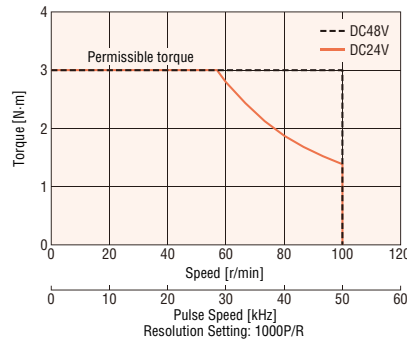

### Notes

● The speed-torque characteristics are data based upon our measurement conditions. When these conditions change, these characteristics may change.

● Depending on the driving conditions, a considerable amount of heat may be generated by the motor. Be sure to keep the motor case temperature at 80°C or less in order to protect the ABZO sensor. (When conforming to the UL standards, it is required to keep the temperature of the motor case at 75°C or less, since the motor is recognized as thermal class A.)

# FC Geared Type Frame Size 60 mm

## Specifications



| Motor Product Name                          | Single Shaft                               | AZM66AK-FC7.2□A                                | AZM66AC-FC10□A | AZM66AK-FC20□A | AZM66AK-FC30□A |
|---|--|--|----------------|----------------|----------------|
|   | With Electromagnetic Brake                 | AZM66MK-FC7.2□A                                | AZM66MC-FC10□A | AZM66MK-FC20□A | AZM66MK-FC30□A |
| Driver Product Name                         | Built-in Controller Type                   | AZD-KD   |                |                |                |
|   | Pulse-Input Type with RS-485 Communication | AZD-KX   |                |                |                |
|   | Pulse Input Type                           | AZD-K  |                |                |                |
| Maximum Holding Torque                      | N·m  | 2.5  | 3.5            | 7              | 10             |
| Rotor Inertia                               | J: kg·m <sup>2</sup>                       | 370×10 <sup>-7</sup> (530×10 <sup>-7</sup> )*1 |                |                |                |
| Gear Ratio                                  |  | 7.2  | 10             | 20             | 30             |
| Resolution                                  | Resolution Setting: 1000P/R                | 0.05°/Pulse                                    | 0.036°/Pulse   | 0.018°/Pulse   | 0.012°/Pulse   |
| Permissible Torque                          | N·m  | 2.5  | 3.5            | 7              | 10             |
| Holding Torque at Power ON                  | N·m  | 2.5  | 3.5            | 7              | 10             |
| Motor Standstill With Electromagnetic Brake | N·m  | 2.5  | 3.5            | 7              | 10             |
| Speed Range                                 | r/min                                      | 0~416  | 0~300          | 0~150          | 0~100          |
| Backlash                                    | arcmin                                     | 15 (0.25°)                                     |                | 10 (0.17°)     |                |
| Power Supply Input Voltage                  |  | 24 VDC±5%*2/48 VDC±5%*3                        |                |                |                |
| Power Supply Input Input Current            | A  | 3.35 (3.8)*1                                   |                |                |                |

● Either **U** (up) or **D** (down) indicating the cable withdrawing direction is entered where the box □ is located within the product name.

\*1 The brackets ( ) indicate the specifications for the product with an electromagnetic brake.

\*2 For the type with an electromagnetic brake, a 24 VDC±4% specification applies if the wiring distance between the motor and driver is extended to 20 m using a cable.

\*3 When operating with 48 VDC input, set inertia load to approximately 10 times or less that of the rotor inertia ratio, and twice that of the safety rate when calculating accelerator torque.

\*4 Only for the Motor.

## Speed - Torque Characteristics (Reference Value)

**AZM66 Gear Ratio 7.2**

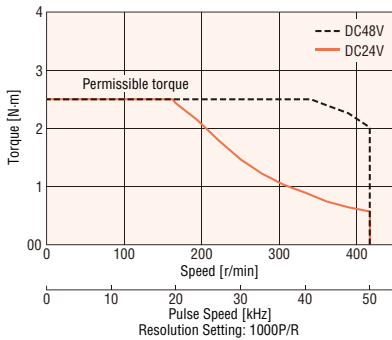

**AZM66 Gear Ratio 10**

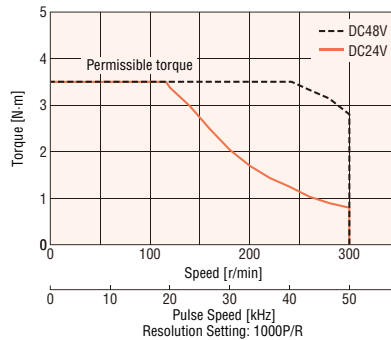

**AZM66 Gear Ratio 20**

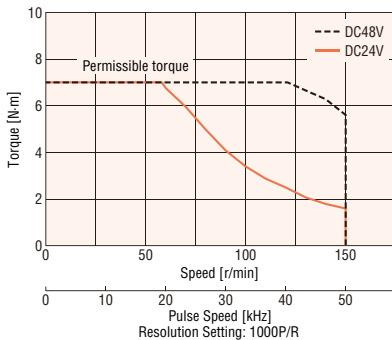

**AZM66 Gear Ratio 30**

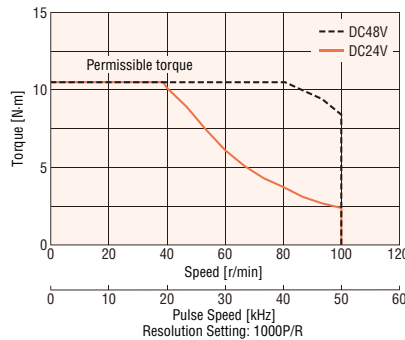

### Notes

● The speed-torque characteristics are data based upon our measurement conditions. When these conditions change, these characteristics may change.

● Depending on the driving conditions, a considerable amount of heat may be generated by the motor. Be sure to keep the motor case temperature at 80°C or less in order to protect the ABZO sensor. (When conforming to the UL standards, it is required to keep the temperature of the motor case at 75°C or less, since the motor is recognized as thermal class A.)

# PS Geared Type Frame Size 42mm

## Specifications



| Motor Product Name                     | Single Shaft                               | <b>AZM46AK-PS5</b>                            | <b>AZM46AK-PS7.2</b> | <b>AZM46AK-PS10</b> | <b>AZM46AK-PS25</b> | <b>AZM46AK-PS36</b> | <b>AZM46AK-PS50</b> |
|--|--|---|----------------------|---------------------|---------------------|---------------------|---------------------|
|  | With Electromagnetic Brake                 | <b>AZM46MK-PS5</b>                            | <b>AZM46MK-PS7.2</b> | <b>AZM46MK-PS10</b> | <b>AZM46MK-PS25</b> | <b>AZM46MK-PS36</b> | <b>AZM46MK-PS50</b> |
| Driver Product Name                    | Built-in Controller Type                   | <b>AZD-KD</b>                                 |                      |                     |                     |                     |                     |
|  | Pulse-Input Type with RS-485 Communication | <b>AZD-KX</b>                                 |                      |                     |                     |                     |                     |
|  | Pulse Input Type                           | <b>AZD-K</b>                                  |                      |                     |                     |                     |                     |
| Maximum Holding Torque                 | N·m  | 1   | 1.5                  | 2.5                 | 3                   |                     |                     |
| Rotor Inertia                          | J: kg·m <sup>2</sup>                       | $55 \times 10^{-7}$ ( $71 \times 10^{-7}$ )*1 |                      |                     |                     |                     |                     |
| Gear Ratio                             |  | 5   | 7.2                  | 10                  | 25                  | 36                  | 50                  |
| Resolution                             | Resolution Setting: 1000P/R                | 0.072°/Pulse                                  | 0.05°/Pulse          | 0.036°/Pulse        | 0.0144°/Pulse       | 0.01°/Pulse         | 0.0072°/Pulse       |
| Permissible Torque                     | N·m  | 1   | 1.5                  | 2.5                 | 3                   |                     |                     |
| Max. Instantaneous Torque*             | N·m  | *   | 2                    | 6                   | *                   | 6                   |                     |
| Holding Torque at Power ON             | N·m  | 0.75  | 1                    | 1.5                 | 2.5                 | 3                   |                     |
| Motor Standstill Electromagnetic Brake | N·m  | 0.75  | 1                    | 1.5                 | 2.5                 | 3                   |                     |
| Speed Range                            | r/min                                      | 0~600   | 0~416                | 0~300               | 0~120               | 0~83                | 0~60                |
| Backlash                               | arcmin                                     | 15 (0.25°)                                    |                      |                     |                     |                     |                     |
| Power Supply Input                     | Voltage                                    | 24 VDC ± 5%*2 / 48 VDC ± 5%                   |                      |                     |                     |                     |                     |
|  | Input Current                              | A   | 1.72 (1.8)*1         |                     |                     |                     |                     |

\*For the geared motor output torque, refer to the speed – torque characteristics.

\*1 The brackets ( ) indicate the specifications for the product with an electromagnetic brake.

\*2 For the type with an electromagnetic brake, a 24 VDC ± 4% specification applies if the wiring distance between the motor and driver is extended to 20 m using a cable.

\*3 Only for the Motor.

## Speed - Torque Characteristics (Reference Value)

**AZM46 Gear Ratio 5**

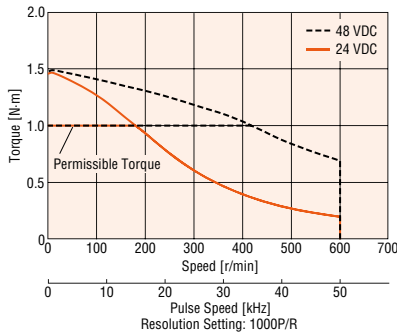

**AZM46 Gear Ratio 7.2**

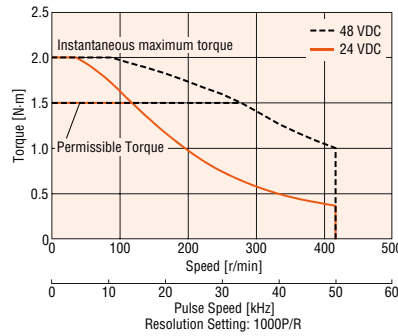

**AZM46 Gear Ratio 10**

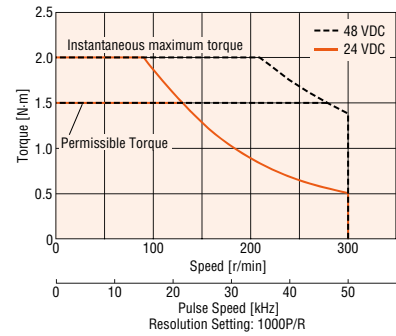

**AZM46 Gear Ratio 25**

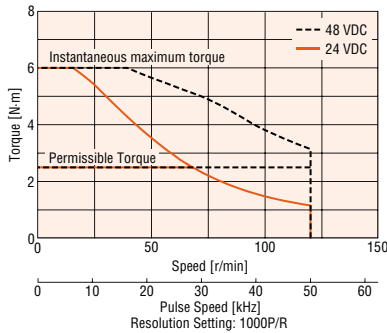

**AZM46 Gear Ratio 36**

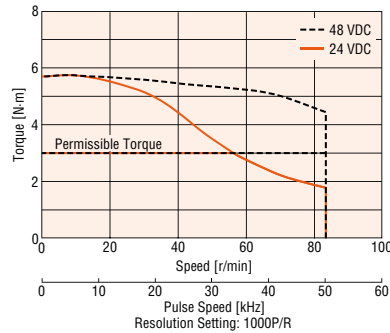

**AZM46 Gear Ratio 50**

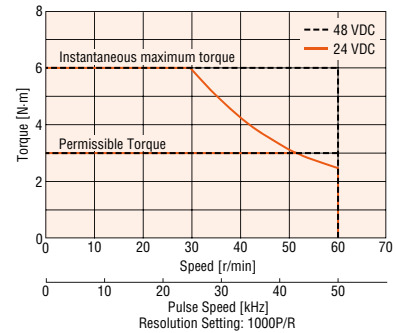

### Notes

- The speed-torque characteristics are data based upon our measurement conditions. When these conditions change, these characteristics may change.
- Depending on the driving conditions, a considerable amount of heat may be generated by the motor. Be sure to keep the motor case temperature at 80°C or less in order to protect the ABZO sensor. (When conforming to the UL standards, it is required to keep the temperature of the motor case at 75°C or less, since the motor is recognized as thermal class A.)

# PS Geared Type Frame Size 60 mm

## Specifications



| Motor Product Name         | Single Shaft                               | AZM66AK-PS5                                    | AZM66AK-PS7.2 | AZM66AK-PS10 | AZM66AK-PS25  | AZM66AK-PS36 | AZM66AK-PS50  |
|----------------------------|--|--|---------------|--------------|---------------|--------------|---------------|
|                            | With Electromagnetic Brake                 | AZM66MK-PS5                                    | AZM66MK-PS7.2 | AZM66MK-PS10 | AZM66MK-PS25  | AZM66MK-PS36 | AZM66MK-PS50  |
| Driver Product Name        | Built-in Controller Type                   | AZD-KD   |               |              |               |              |               |
|                            | Pulse-Input Type with RS-485 Communication | AZD-KX   |               |              |               |              |               |
|                            | Pulse Input Type                           | AZD-K  |               |              |               |              |               |
| Maximum Holding Torque     | N·m  | 3.5  | 4             | 5            | 8             |              |               |
| Rotor Inertia              | J: kg·m <sup>2</sup>                       | 370×10 <sup>-7</sup> (530×10 <sup>-7</sup> )*1 |               |              |               |              |               |
| Gear Ratio                 |  | 5  | 7.2           | 10           | 25            | 36           | 50            |
| Resolution                 | Resolution Setting: 1000P/R                | 0.072°/Pulse                                   | 0.05°/Pulse   | 0.036°/Pulse | 0.0144°/Pulse | 0.01°/Pulse  | 0.0072°/Pulse |
| Permissible Torque         | N·m  | 3.5  | 4             | 5            | 8             |              |               |
| Max. Instantaneous Torque* | N·m  | *  | *             | *            | *             | *            | 20            |
| Holding Torque at          | Power ON                                   | 2.5  | 3.6           | 5            | 7.6           | 8            |               |
|                            | Electromagnetic Brake                      | 2.5  | 3.6           | 5            | 7.6           | 8            |               |
| Speed Range                | r/min                                      | 0~600  | 0~416         | 0~300        | 0~120         | 0~83         | 0~60          |
| Backlash                   | arcmin                                     | 7 (0.12°)                                      |               |              |               | 9 (0.15°)    |               |
| Power Supply Input         | Voltage                                    | 24 VDC±5%*2/48 VDC±5%*3                        |               |              |               |              |               |
|                            | Input Current                              | 3.55 (3.8)*1                                   |               |              |               |              |               |

\*For the geared motor output torque, refer to the speed – torque characteristics.

\*1 The brackets ( ) indicate the specifications for the product with an electromagnetic brake.

\*2 For the type with an electromagnetic brake, a 24 VDC±4% specification applies if the wiring distance between the motor and driver is extended to 20 m using a cable.

\*3 When operating with 48 VDC input, set inertia load to approximately 10 times or less that of the rotor inertia ratio, and twice that of the safety rate when calculating accelerator torque.

\*4 Only for the Motor.

## Speed - Torque Characteristics (Reference Value)

**AZM66 Gear Ratio 5**

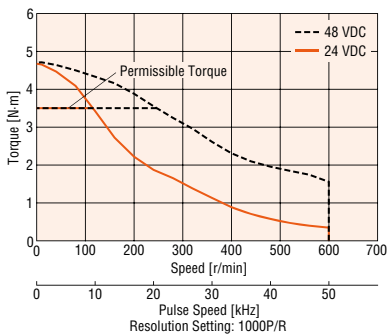

**AZM66 Gear Ratio 7.2**

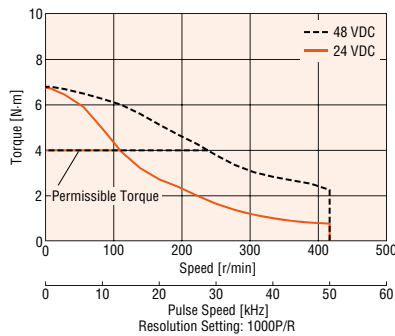

**AZM66 Gear Ratio 10**

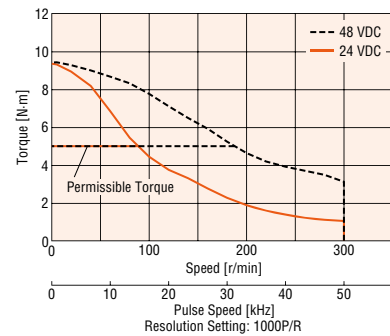

**AZM66 Gear Ratio 25**

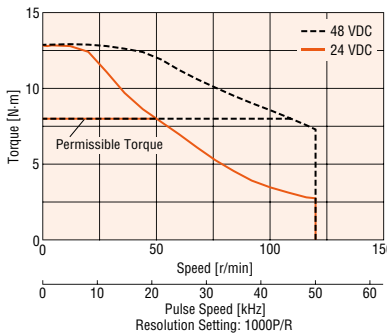

**AZM66 Gear Ratio 36**

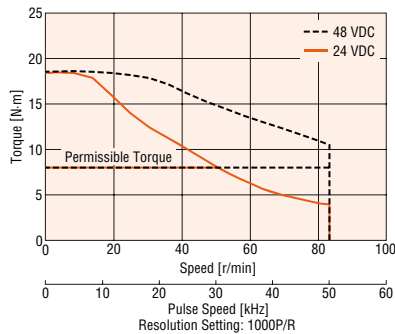

**AZM66 Gear Ratio 50**

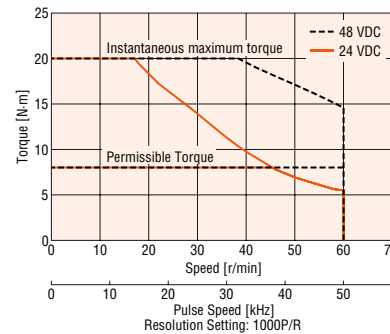

### Notes

- The speed-torque characteristics are data based upon our measurement conditions. When these conditions change, these characteristics may change.
- Depending on the driving conditions, a considerable amount of heat may be generated by the motor. Be sure to keep the motor case temperature at 80°C or less in order to protect the ABZO sensor. (When conforming to the UL standards, it is required to keep the temperature of the motor case at 75°C or less, since the motor is recognized as thermal class A.)

Features

System Configuration

Product Line

AC Input

Specifications and Features

Dimensions

Connection and Operation

System Configuration

Product Line

Specifications and Features

DC Input

Dimensions and Operation

Connection and Operation

Multiaxis Driver

Accessories

# HPG Geared Type Frame Size 40 mm, 60 mm

## Specifications



| Motor Product Name                         | Single Shaft                | AZM46AK-HP5□   | AZM46AK-HP9□                                 | AZM66AK-HP5□   | AZM66AK-HP15□                              |
|--|-----------------------------|--|--|--|--|
| With Electromagnetic Brake                 |                             | AZM46MK-HP5□   | AZM46MK-HP9□                                 | AZM66MK-HP5□   | AZM66MK-HP15□                              |
| Driver Product Name                        | Built-in Controller Type    | AZD-KD   |  |  |  |
| Pulse-Input Type with RS-485 Communication |                             | AZD-KX   |  |  |  |
| Pulse Input Type                           |                             | AZD-K  |  |  |  |
| Maximum Holding Torque                     | N·m                         | 1.5  | 2.5  | 5  | 9  |
| Rotor Inertia                              | J: kg·m <sup>2</sup>        | 55×10 <sup>-7</sup> (71×10 <sup>-7</sup> )* <sup>1</sup> |  | 370×10 <sup>-7</sup> (530×10 <sup>-7</sup> )* <sup>1</sup> |  |
| Inertia* <sup>2</sup>                      | J: kg·m <sup>2</sup>        | 5.8×10 <sup>-7</sup> (4.2×10 <sup>-7</sup> )             | 3.4×10 <sup>-7</sup> (2.9×10 <sup>-7</sup> ) | 92×10 <sup>-7</sup> (86×10 <sup>-7</sup> )                 | 78×10 <sup>-7</sup> (77×10 <sup>-7</sup> ) |
| Gear Ratio                                 |                             | 5  | 9  | 5  | 15   |
| Resolution                                 | Resolution Setting: 1000P/R | 0.072°/Pulse   | 0.04°/Pulse                                  | 0.072°/Pulse   | 0.024°/Pulse                               |
| Permissible Torque*                        | N·m                         | *  | 2.5  | *  | 9  |
| Max. Instantaneous Torque*                 | N·m                         | *  | *  | *  | *  |
| Holding Torque at Power ON                 | N·m                         | 0.75   | 1.35   | 2.5  | 7.5  |
| Holding Torque at Motor Standstill         | Electromagnetic Brake N·m   | 0.75   | 1.35   | 2.5  | 7.5  |
| Speed Range                                | r/min                       | 0~800  | 0~444  | 0~600  | 0~200                                      |
| Backlash                                   | arcmin                      | 3 (0.05°)  |  |  |  |
| Power Supply Input                         | Voltage                     | 24 VDC±5%* <sup>4</sup> /48 VDC±5%* <sup>5</sup>         |  |  |  |
|  | Input Current               | 1.72 (1.8)* <sup>1</sup>                                 |  | 3.55 (3.8)* <sup>1</sup>                                   |  |
| Output Flange Surface Runout* <sup>3</sup> | mm                          | 0.02   |  |  | 0.04                                       |
| Output Flange Inner Runout* <sup>3</sup>   | mm                          | 0.03   |  |  | 0.04                                       |

\*For the output torque as a geared motor, see the speed-torque characteristics.

● For the flange output type, **F** is specified where the box □ is located in the product name.

\*<sup>1</sup> The values inside the brackets ( ) represent the specification for the electromagnetic brake type.

\*<sup>2</sup> This is the value with the inertia moment inside the gear section converted into the motor shaft. The value within ( ) is the flange output type.

\*<sup>3</sup> This is the flange output type value.

\*<sup>4</sup> If the wiring distance between the electromagnetic brake type motor and driver is extended to 20 m using an accessory cable (sold separately), the 24 VDC±4% specification applies.

\*<sup>5</sup> When operating with 48 VDC input, set inertia load to approximately 10 times or less that of the rotor inertia ratio, and twice that of the safety rate when calculating accelerator torque. (excluding

### AZM46)

\*<sup>6</sup> Only for the Motor.

## Speed - Torque Characteristics (Reference Value)

**AZM46 Gear Ratio 5**

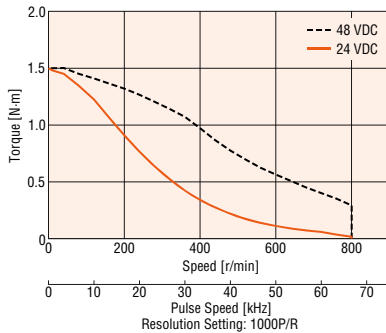

**AZM46 Gear Ratio 9**

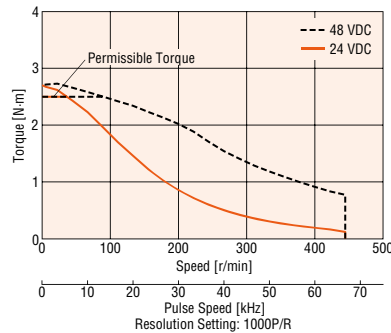

**AZM66 Gear Ratio 5**

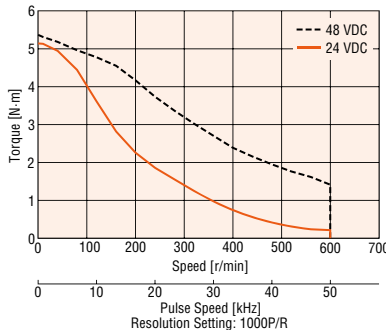

**AZM66 Gear Ratio 15**

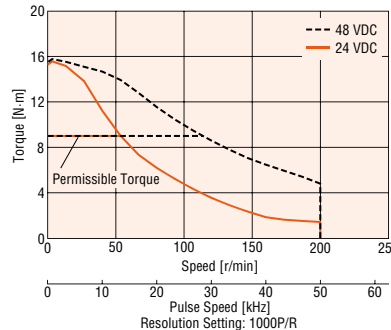

### Notes

● The speed-torque characteristics are data based upon our measurement conditions. When these conditions change, these characteristics may change.

● Depending on the driving conditions, a considerable amount of heat may be generated by the motor. Be sure to keep the motor case temperature at 80°C or less in order to protect the ABZO sensor. (When conforming to the UL standards, it is required to keep the temperature of the motor case at 75°C or less, since the motor is recognized as thermal class A.)



# Harmonic Geared Type Frame Size 42mm, 60 mm

## Specifications



| Motor Product Name                     | Single Shaft                               | <b>AZM46AK-HS50</b>                           | <b>AZM46AK-HS100</b>       | <b>AZM66AK-HS50</b>                             | <b>AZM66AK-HS100</b>       |
|--|--|---|----------------------------|---|----------------------------|
|  | With Electromagnetic Brake                 | <b>AZM46MK-HS50</b>                           | <b>AZM46MK-HS100</b>       | <b>AZM66MK-HS50</b>                             | <b>AZM66MK-HS100</b>       |
| Driver Product Name                    | Built-in Controller Type                   | <b>AZD-KD</b>                                 |                            |   |                            |
|  | Pulse-Input Type with RS-485 Communication | <b>AZD-KX</b>                                 |                            |   |                            |
|  | Pulse Input Type                           | <b>AZD-K</b>                                  |                            |   |                            |
| Maximum Holding Torque                 | N·m  | 3.5   | 5                          | 7   | 10                         |
| Rotor Inertia                          | J: kg·m <sup>2</sup>                       | $72 \times 10^{-7}$ ( $88 \times 10^{-7}$ )*1 |                            | $405 \times 10^{-7}$ ( $565 \times 10^{-7}$ )*1 |                            |
| Gear Ratio                             |  | 50  | 100                        | 50  | 100                        |
| Resolution                             | Resolution Setting: 1000P/R                | 0.0072°/Pulse                                 | 0.0036°/Pulse              | 0.0072°/Pulse                                   | 0.0036°/Pulse              |
| Permissible Torque                     | N·m  | 3.5   | 5                          | 7   | 10                         |
| Max. Instantaneous Torque*             | N·m  | 8.3   | 11                         | *   | 36                         |
| Holding Torque at Power ON             | N·m  | 3.5   | 5                          | 7   | 10                         |
| Motor Standstill Electromagnetic Brake | N·m  | 3.5   | 5                          | 7   | 10                         |
| Speed Range                            | r/min                                      | 0~70  | 0~35                       | 0~60  | 0~30                       |
| Lost Motion (Load Torque)              | arcmin                                     | 1.5 Max. ( $\pm 0.16$ N·m)                    | 1.5 Max. ( $\pm 0.20$ N·m) | 0.7 Max. ( $\pm 0.28$ N·m)                      | 0.7 Max. ( $\pm 0.39$ N·m) |
| Power Supply Input                     | Voltage                                    | 24 VDC $\pm 5\%$ *2/48 VDC $\pm 5\%$ *3       |                            |   |                            |
|  | Input Current                              | A   | 1.72 (1.8)*1               |   | 3.55 (3.8)*1               |

\*For the output torque as a geared motor, see the speed-torque characteristics.

\*1 The values inside the brackets ( ) represent the specification for the electromagnetic brake type.

\*2 If the wiring distance between the electromagnetic brake type motor and driver is extended to 20 m using an accessory cable (sold separately), the 24 VDC  $\pm 4\%$  specification applies.

\*3 When operating with 48 VDC input, set inertia load to approximately 10 times or less that of the rotor inertia ratio, and twice that of the safety rate when calculating accelerator torque. (excluding

### AZM46

\*4 Only for the Motor.

### Notes

● The rotor inertia represents a sum of the moments of inertia of the harmonic gear converted to motor shaft values.

## Speed - Torque Characteristics (Reference Value)

**AZM46 Gear Ratio 50**

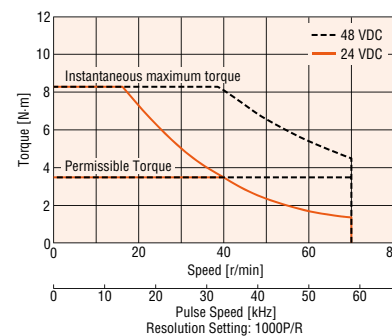

**AZM46 Gear Ratio 100**

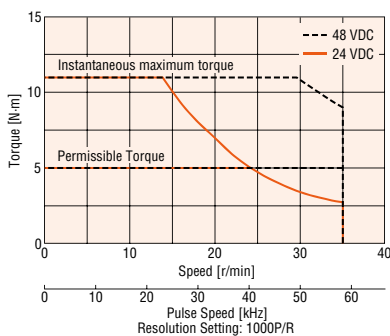

**AZM66 Gear Ratio 50**

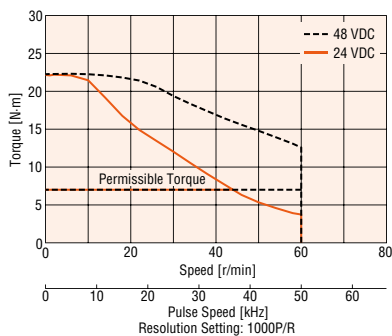

**AZM66 Gear Ratio 100**

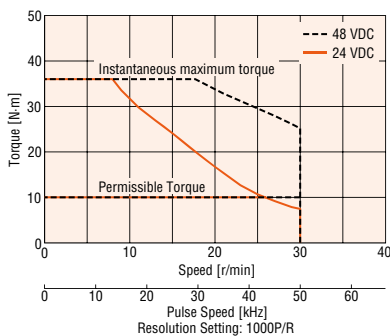

### Notes

● The speed-torque characteristics are data based upon our measurement conditions. When these conditions change, these characteristics may change.

● Depending on the driving conditions, a considerable amount of heat may be generated by the motor. Be sure to keep the motor case temperature at 80°C or less in order to protect the ABZO sensor. (When conforming to the UL standards, it is required to keep the temperature of the motor case at 75°C or less, since the motor is recognized as thermal class A.)

Features

System Configuration

Product Line

Specifications and Features

Dimensions

Connection and Operation

System Configuration

Product Line

Specifications and Features

DC Input

Dimensions

Connection and Operation

Multiaxis Driver

Accessories

## Driver Specifications

| Driver Type                   | Built-in Controller Type                          | Pulse-Input Type with RS-485 Communication        | Pulse Input Type  |     |     |
|-------------------------------|---|---|---|-----|-----|
| Driver Product Name           | <b>AZD-KD</b>                                     | <b>AZD-KX</b>                                     | <b>AZD-K</b>  |     |     |
| I/O Function                  | Max. Input Pulse Frequency                        | —   | Line driver output by programmable controller: 1 MHz (When the pulse duty is 50%)<br>Open-collector output by programmable controller: 250 kHz (When the pulse duty is 50%)<br>Negative Logic Pulse Input (Initial value) |     |     |
|                               | Number of Positioning Data Sets                   | 256 Points  | 256 Points*1  |     |     |
|                               | Direct Input                                      | 10 Points   | 6 Points  |     |     |
|                               | Direct Output                                     | 6 Points  |   |     |     |
|                               | RS-485 Communication Network Input                | 16 Points   | —   |     |     |
|                               | RS-485 Communication Network Output               | 16 Points   | —   |     |     |
| Setting Tool                  | Data Setting Software <b>MEXE02</b>               | ○   |   |     |     |
| Coordinates Management Method | Battery-free Absolute System                      |   |   |     |     |
| Operation                     | Operating Method                                  | Positioning operation                             | ○   | ○*1 |     |
|                               |   | Positioning Push-Motion Operation*2               | ○   | ○*1 |     |
|                               | Positioning Operation                             | Connecting Method                                 | Independent Operation   | ○   | ○*1 |
|                               |   |   | Sequential Operation  | ○   | ○*1 |
|                               |   | Multistep Speed-Change (Configuration Connection) | ○   | ○*1 |     |
|                               | Sequence Control                                  | Loop Operation (Repeating)                        | ○   | ○*1 |     |
|                               |   | Event Jump Operation                              | ○   | ○*1 |     |
|                               | Continuous Operation                              | Pushing   | Position Control  | ○   | ○*1 |
|                               |   |   | Speed Control   | ○   | ○*1 |
|                               |   |   | Torque Control  | ○   | ○*1 |
|                               |   |   | Pushing   | ○   | ○*1 |
|                               | Return-to-Home Operation                          | Return-to-Home Operation                          | ○   | ○   |     |
|                               |   | High Speed Return-to-Home Operation               | ○   | ○   |     |
|                               | JOG Operation                                     |   | ○   | ○   |     |
| Monitor/Information           | Waveform Monitoring                               | ○   | ○   |     |     |
|                               | Overload Detection                                | ○   | ○   |     |     |
|                               | Overheat Detection (Motor · Driver)               | ○   | ○   |     |     |
|                               | Position · Speed Information                      | ○   | ○   |     |     |
|                               | Temperature Detection (Motor · Driver)            | ○   | ○   |     |     |
|                               | Motor Load Factor                                 | ○   | ○   |     |     |
| Alarm                         | Distance Traveled · Integrating Distance Traveled | ○   | ○   |     |     |

\*1 This can be used by setting with the data setting software **MEXE02**.

## Built-in Controller Type RS-485 Communication Specifications

|                            |  |
|----------------------------|--|
| Protocol                   | Modbus RTU Mode  |
| Electrical Characteristics | EIA-485 Based, Straight Cable<br>Use shielded twisted-pair cables (TIA/EIA-568B CAT5e or better recommended). The max. total extension length is 50 m. |
| Communication Mode         | Half duplex and start-stop synchronization (data: 8 bits, stop bit: 1 bit or 2 bits, parity: none, even, or odd)                                       |
| Baud Rate                  | 9600 bps/19200 bps/38400 bps/57600 bps/115200 bps/230400 bps are available   |
| Connection Type            | Up to 31 units can be connected to a single programmable controller (master equipment).  |

## Electromagnetic Brake Specifications

| Product Name          | <b>AZM46</b>             | <b>AZM66</b> | <b>AZM69</b> |
|-----------------------|--------------------------|--------------|--------------|
| Type                  | Power Off Activated Type |              |              |
| Power Supply Voltage  | 24 VDC ±5%*              |              |              |
| Power Supply Current  | A                        | 0.08         | 0.25         |
| Brake Activation Time | ms                       | 20           |              |
| Brake Release Time    | ms                       | 30           |              |
| Time Rating           | Continuous               |              |              |

\*If a 20 m extension cable is used for the electromagnetic brake type, the 24 VDC±4% specification applies.

● The product names are listed such that the product names are distinguishable.

## General Specifications

|   |                     | Motor  | Driver   |
|---|---------------------|--|--|
| Thermal Class   |                     | [UL 105 (A) certified]   | —  |
| Insulation Resistance                                 |                     | 100 MΩ or more when a 500 VDC megger is applied between the following places:<br>• Case – Motor Windings<br>• Case – Electromagnetic Brake Windings*1  | 100 MΩ or more when a 500 VDC megger is applied between the following places:<br>• Protective Earth Terminal – Power Supply Terminal |
| Dielectric Voltage                                    |                     | Sufficient to withstand the following for 1 minute:<br><b>AZM14, AZM15, AZM24, AZM26</b><br>• Case – Motor Windings 0.5 kVAC, 50 Hz or 60 Hz<br><b>AZM46, AZM48, AZM66, AZM69</b><br>• Case – Motor Windings 1.0 kVAC, 50 Hz or 60 Hz<br>• Case – Electromagnetic Brake Windings*1 1.0 kVAC 50 Hz or 60 Hz | —  |
| Operating Environment (In operation)                  | Ambient Temperature | 0~+40°C (Non-freezing)   | 0~+50°C (Non-freezing)   |
|   | Ambient Humidity    | 85% or less (Non-condensing)   |  |
|   | Atmosphere          | No corrosive gases or dust. The product should not be exposed to water, oil or other liquids.  |  |
| Degree of Protection                                  |                     | <b>AZM14, AZM15, AZM24, AZM26:</b><br>IP40 (excluding installation surfaces and connector locations)<br><b>AZM46, AZM48, AZM66, AZM69:</b><br>IP66 (excluding installation surfaces and connector locations)   | IP10   |
| Stop Position Accuracy                                |                     | <b>AZM14, AZM15, AZM24, AZM26:</b> ±5 minutes (±0.083°) <b>AZM46, AZM48:</b> ±4 minutes (±0.067°)<br><b>AZM66, AZM69:</b> ±3 minutes (±0.05°)  |  |
| Shaft Runout  |                     | 0.05 T.I.R. (mm)*2   | —  |
| Concentricity of Installation Pilot to the Shaft      |                     | 0.075 T.I.R. (mm)*2  | —  |
| Perpendicularity of Installation Surface to the Shaft |                     | 0.075 T.I.R. (mm)*2  | —  |
| Multiple Rotation Detection Range Upon Power OFF      |                     | <b>AZM14, AZM15, AZM24, AZM26:</b> ±450 rotations (900 rotations)<br><b>AZM46, AZM48, AZM66, AZM69:</b> ±900 rotations (1,800 rotations)   |  |

\*1 Only for products with an electromagnetic brake.

\*2 T. I. R. (Total Indicator Reading): The total dial gauge reading when the measurement section is rotated once around the reference axis center.

### Note

- Do not measure insulation resistance or perform a dielectric strength test while the motor and driver are connected. Also, do not perform these tests on the motor absolute sensor part.

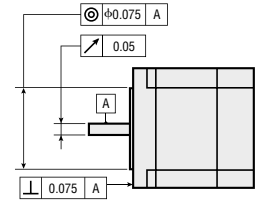

## Rotation Direction

This refers to the direction viewed from the output shaft side.

The rotation direction of the gear output shaft with respect to the standard type motor output shaft differs depending on the type of gear and gear ratio.

Refer to the following table.

| Type   | Gear Ratio          | Rotation Direction with Respect to Motor Output Shaft |
|--|---------------------|---|
| <b>TS</b> Geared Type                          | <b>3.6, 7.2, 10</b> | Same direction  |
|  | <b>20, 30</b>       | Opposite direction                                    |
| <b>FC</b> Geared Type<br><b>PS</b> Geared Type | All gear ratios     | Same direction  |
| <b>HPG</b> Geared Type<br>Harmonic Geared Type | All gear ratios     | Opposite direction                                    |

### Standard Type Motor

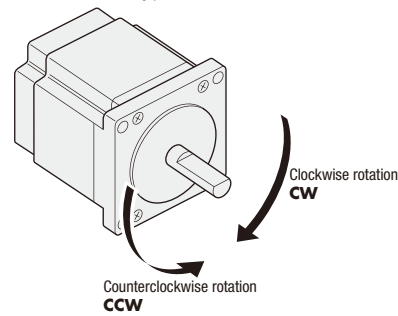

## Motor Installation

Since the ABZO sensor is easily affected by a magnetic field, make sure the installation location.

### Motor installation of frame size 28 mm or smaller

When motors are installed side by side, ensure the distance among motors or more than the frame size in horizontal and vertical directions.

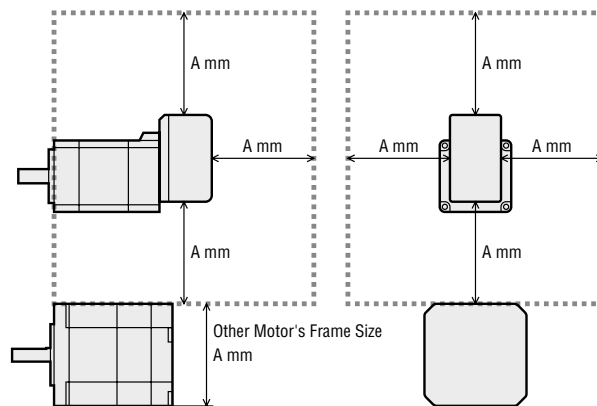

### Reference

| The other motor  | A     |
|------------------|-------|
| Frame Size 20 mm | 20 mm |
| Frame Size 28 mm | 28 mm |
| Frame Size 42 mm | 42 mm |
| Frame Size 60 mm | 60 mm |

- Leave a minimum distance of the other motor's frame size (A mm) or larger.

● Motor Installation within an Magnetic Field Ensure that the magnetic flux density of the ABZO sensor surface does not exceed the values shown in the overview.

| Motor Frame Size | Magnetic Flux Density |
|------------------|-----------------------|
| 28 mm or smaller | 2mT*                  |
| 42 mm or larger  | 10mT                  |

\*Between 1-2 mT ensure that the ambient temperature is between 20-40°C.

## Permissible Radial Load and Permissible Axial Load

Unit: N

| Type                 | Motor Frame Size | Product             | Gear Ratio             | Permissible Radial Load    |     |     |     |     | Permissible Axial Load |
|----------------------|------------------|---------------------|------------------------|----------------------------|-----|-----|-----|-----|------------------------|
|                      |                  |                     |                        | Distance from Shaft End mm |     |     |     |     |                        |
|                      |                  |                     |                        | 0                          | 5   | 10  | 15  | 20  |                        |
| Standard Type        | 20 mm            | <b>AZM14, AZM15</b> | -                      | 12                         | 15  | -   | -   | -   | 3                      |
|                      | 28 mm            | <b>AZM24, AZM26</b> |                        | 25                         | 34  | 52  | -   | -   | 5                      |
|                      | 42 mm            | <b>AZM46</b>        |                        | 35                         | 44  | 58  | 85  | -   | 15                     |
|                      |                  | <b>AZM48</b>        |                        | 30                         | 35  | 44  | 58  | 85  |                        |
|                      | 60 mm            | <b>AZM66, AZM69</b> |                        | 90                         | 100 | 130 | 180 | 270 | 30                     |
| TS Geared Type       | 42 mm            | <b>AZM46</b>        | <b>3.6, 7.2, 10</b>    | 20                         | 30  | 40  | 50  | -   | 15                     |
|                      |                  |                     | <b>20, 30</b>          | 40                         | 50  | 60  | 70  | -   |                        |
|                      | 60 mm            | <b>AZM66</b>        | <b>3.6, 7.2, 10</b>    | 120                        | 135 | 150 | 165 | 180 | 40                     |
|                      |                  | <b>20, 30</b>       | 170                    | 185                        | 200 | 215 | 230 |     |                        |
| FC Geared Type       | 42 mm            | <b>AZM46</b>        | <b>7.2, 10, 20, 30</b> | 180                        | 200 | 220 | 250 | -   | 100                    |
|                      | 60 mm            | <b>AZM66</b>        |                        | 270                        | 290 | 310 | 330 | -   | 200                    |
| PS Geared Type       | 42 mm            | <b>AZM46</b>        | <b>5</b>               | 70                         | 80  | 95  | 120 | -   | 100                    |
|                      |                  |                     | <b>7.2</b>             | 80                         | 90  | 110 | 140 | -   |                        |
|                      |                  |                     | <b>10</b>              | 85                         | 100 | 120 | 150 | -   |                        |
|                      |                  |                     | <b>25</b>              | 120                        | 140 | 170 | 210 | -   |                        |
|                      |                  |                     | <b>36</b>              | 130                        | 160 | 190 | 240 | -   |                        |
|                      | 60 mm            | <b>AZM66</b>        | <b>5</b>               | 170                        | 200 | 230 | 270 | 320 | 200                    |
|                      |                  |                     | <b>7.2</b>             | 200                        | 220 | 260 | 310 | 370 |                        |
|                      |                  |                     | <b>10</b>              | 220                        | 250 | 290 | 350 | 410 |                        |
|                      |                  |                     | <b>25</b>              | 300                        | 340 | 400 | 470 | 560 |                        |
|                      |                  |                     | <b>36</b>              | 340                        | 380 | 450 | 530 | 630 |                        |
| HPG Geared Type      | 40 mm            | <b>AZM46</b>        | <b>5</b>               | 150                        | 170 | 190 | 230 | 270 | 430                    |
|                      |                  |                     | <b>9</b>               | 180                        | 200 | 230 | 270 | 320 | 510                    |
|                      | 60 mm            | <b>AZM66</b>        | <b>5</b>               | 250                        | 270 | 300 | 330 | 360 | 700                    |
|                      |                  |                     | <b>15</b>              | 360                        | 380 | 420 | 460 | 510 | 980                    |
| Harmonic Geared Type | 42 mm            | <b>AZM46</b>        | <b>50, 100</b>         | 180                        | 220 | 270 | 360 | 510 | 220                    |
|                      | 60 mm            | <b>AZM66</b>        |                        | 320                        | 370 | 440 | 550 | 720 | 450                    |

● The products can be identified with the detailed product code.

● PS geared type, HPG geared type, when either the permissible radial load or permissible axial load are added, shall have a lifespan value satisfying 20,000 hours. For TS and Harmonic geared types lifespan please contact the nearest Oriental Motor sales office.

## Radial Load and Axial Load

Distance from Shaft End [mm]

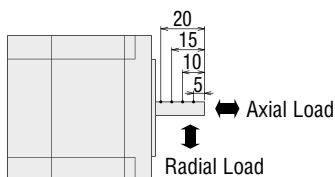

## Permissible Moment Load

If an excentric load is applied when attaching an arm or table to the flange face, calculate the moment load with the following formula. The moment load should not exceed the permissible values shown in the table below.

### HPG Geared Type Flange Output Type

| Product Name | Gear Ratio | Permissible Axial Load (N) | Permissible Moment Load (N·m) | Coefficient a (m) |
|--------------|------------|----------------------------|-------------------------------|-------------------|
| <b>AZM46</b> | <b>5</b>   | 430                        | 4.9                           | 0.006             |
|              | <b>9</b>   | 510                        | 5.9                           |                   |
| <b>AZM66</b> | <b>5</b>   | 700                        | 12.0                          | 0.011             |
|              | <b>15</b>  | 980                        | 17.2                          |                   |

m : Work mass (kg)  
 g : Gravitational acceleration (m/s<sup>2</sup>)  
 F : External force (N)  
 L : Distance from center of output flange  
 a : Coefficient (m)  
 deltaF : Load on output flange side (N)  
 Fs : Permissible axial load (N)  
 deltaM : Moment load (N·m)  
 M : Permissible moment load (N·m)

The required moment load can be calculated according to the following formula.

**Example 1: When external force F (N) is applied at a distance of L (m) from the centre of the output flange**

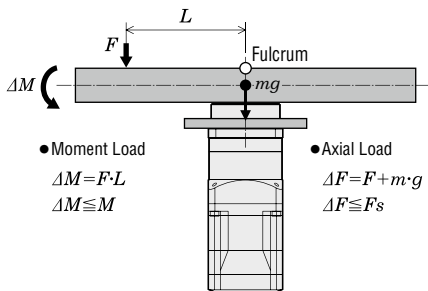

**Example 2: When external force F (N) is applied at a distance of L (m) from the surface mounting of the output flange**

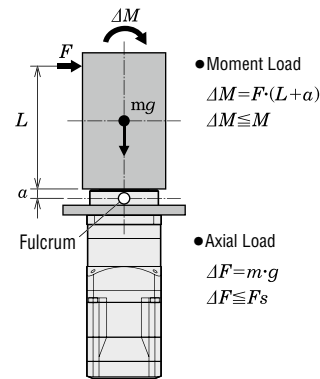

### Harmonic Geared Type

| Product Name | Permissible Axial Load (N) | Permissible Moment Load (N·m) | Coefficient a (m) |
|--------------|----------------------------|-------------------------------|-------------------|
| <b>AZM46</b> | 220                        | 5.6                           | 0.009             |
| <b>AZM66</b> | 450                        | 11.6                          | 0.0114            |

The required moment load can be calculated according to the following formula.

**Example 1: When external force F (N) is applied at a distance of L (m) from the centre of the output flange**

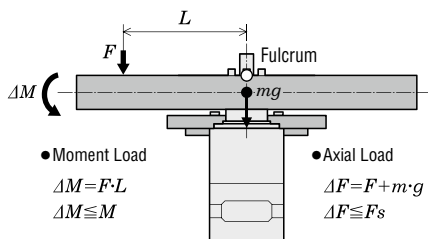

**Example 2: When external force F (N) is applied at a distance of L (m) from the surface mounting of the output flange**

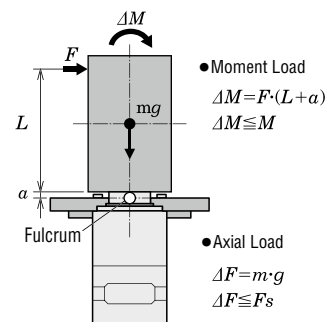

## Load Torque - Driver Input Current Characteristics

The following are the relationships between the load torque and driver input current at each speed when the motor is operated. From these characteristics, it is possible to estimate the current capacity actually required when used with multiple axes. For geared motors, convert to torque and speed at the motor shaft.

$$\text{Motor shaft speed} = \text{Gear output shaft speed} \times \text{Gear ratio} \text{ [r/min]}$$

$$\text{Motor shaft torque} = \frac{\text{Gear output shaft torque}}{\text{Gear Ratio}} \text{ [N}\cdot\text{m]}$$

### 24 VDC

#### AZM14

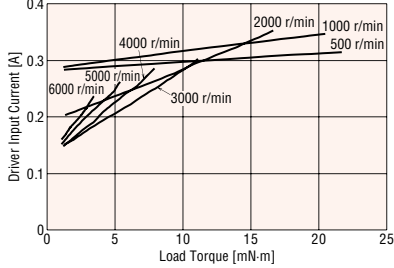

#### AZM15

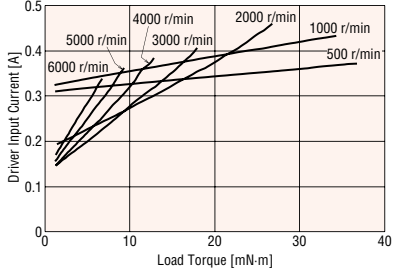

#### AZM24

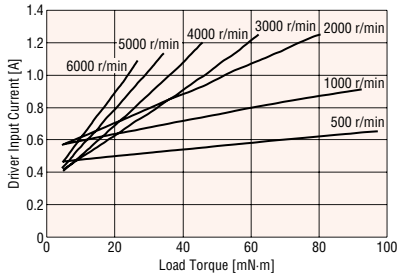

#### AZM26

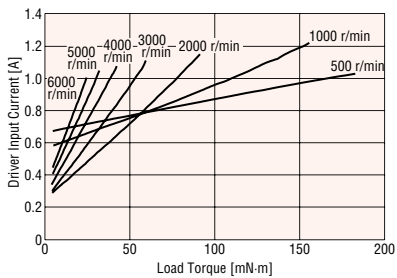

#### AZM46

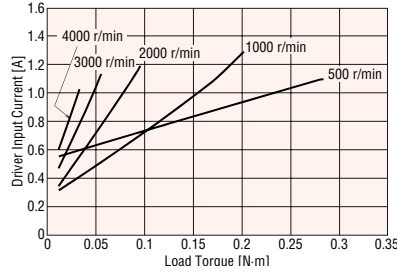

#### AZM48

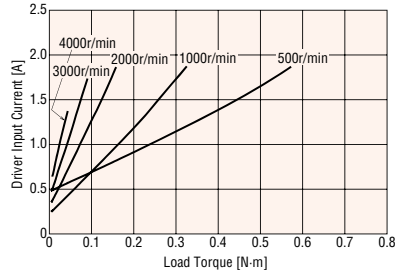

#### AZM66

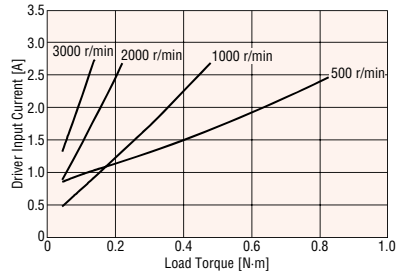

#### AZM69

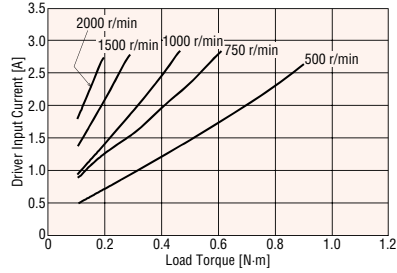

### 48 VDC

#### AZM46

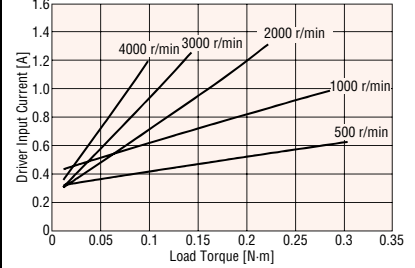

#### AZM48

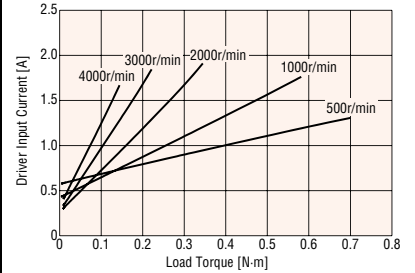

#### AZM66

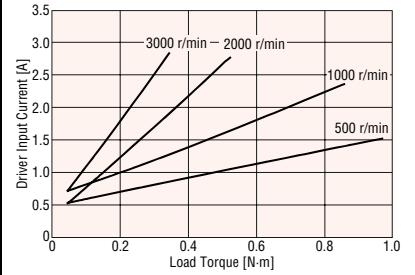

#### AZM69

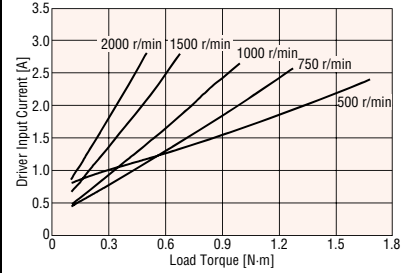

## Dimensions (Unit = mm)

### Motors

#### ◇ Standard Type

#### Frame Size 20 mm

| Product Name   | L  | Mass<br>kg |
|----------------|----|------------|
| <b>AZM14AK</b> | 50 | 0.08       |
| <b>AZM15AK</b> | 60 | 0.1        |

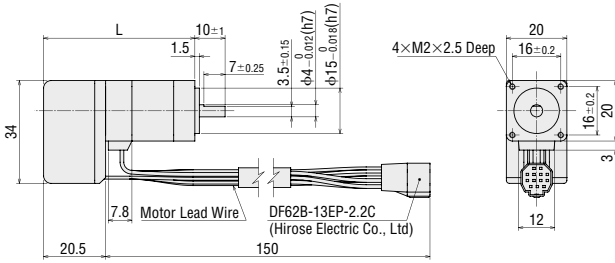

#### Frame Size 28 mm

| Product Name   | L    | Mass<br>kg |
|----------------|------|------------|
| <b>AZM24AK</b> | 54.5 | 0.15       |
| <b>AZM26AK</b> | 74   | 0.24       |

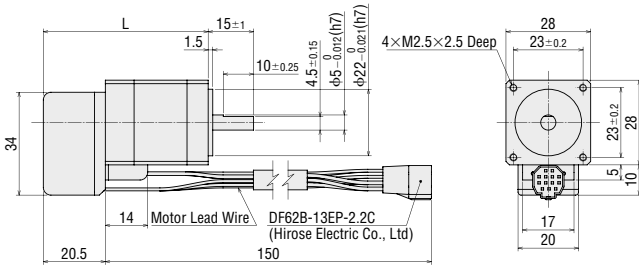

#### Frame Size 42 mm

| Product Name   | Mass<br>kg |
|----------------|------------|
| <b>AZM46□K</b> | 0.44       |

One Side Milled

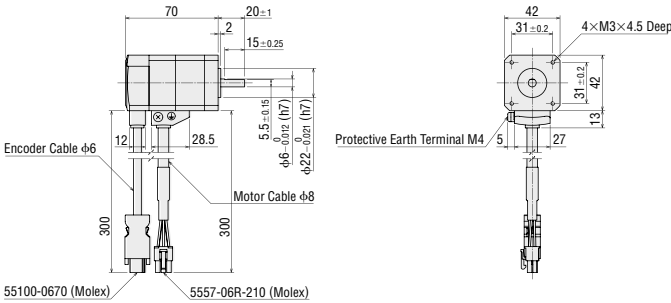

Straight



#### Frame Size 42 mm

| Product Name   | Mass<br>kg |
|----------------|------------|
| <b>AZM48□K</b> | 0.68       |

One Side Milled

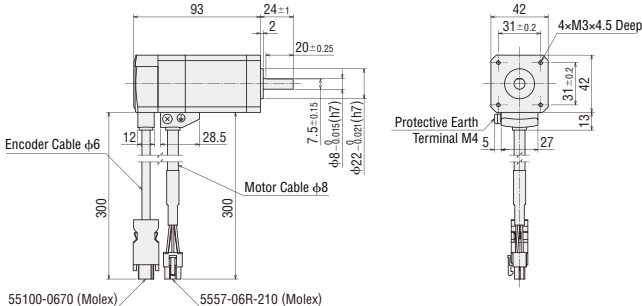

Straight

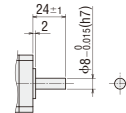

With Key

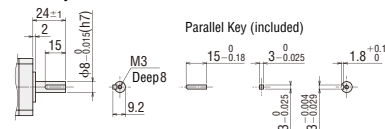

● Either **0** (straight) or **1** (with key) indicating the shaft shape is entered where the box □ is located within the product name. (For **AZM46** straight only).

### Frame Size 60 mm

| Product Name     | L    | Mass kg |
|------------------|------|---------|
| <b>AZM66A</b> □K | 72   | 0.91    |
| <b>AZM69A</b> □K | 97.5 | 1.4     |

One Side Milled

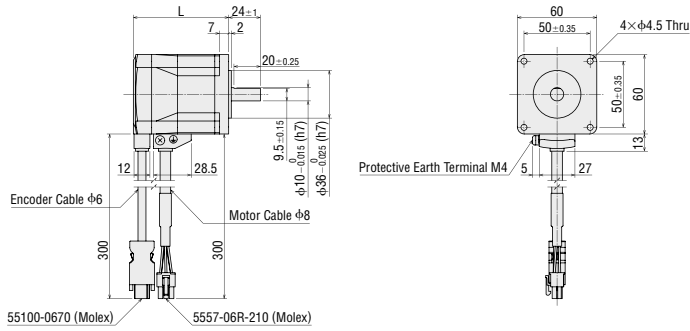

Straight

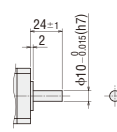

With Key

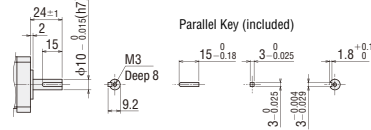

### ◇ Standard Type with Electromagnetic Brake

### Frame Size 42 mm

| Product Name     | Mass kg |
|------------------|---------|
| <b>AZM46M</b> □K | 0.61    |

One Side Milled

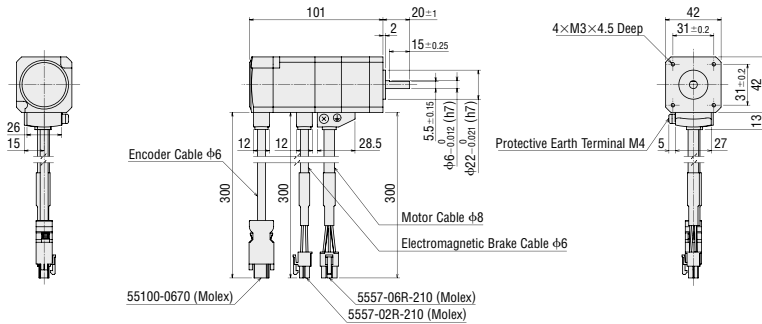

Straight

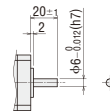

### Frame Size 60 mm

| Product Name     | L     | Mass kg |
|------------------|-------|---------|
| <b>AZM66M</b> □K | 118   | 1.3     |
| <b>AZM69M</b> □K | 143.5 | 1.8     |

One Side Milled

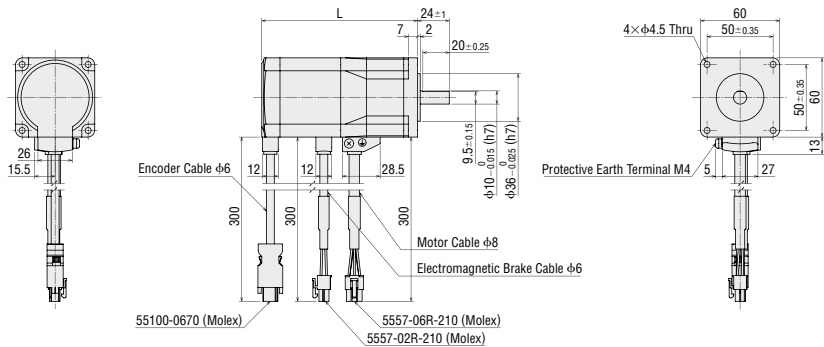

Straight

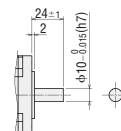

With Key

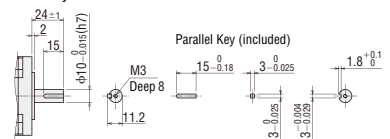

● Either 0 (straight) or 1 (with key) indicating the shaft shape is entered where the box □ is located within the product name. (For **AZM46** straight only).



◆ **TS Geared Type**  
Frame Size 42 mm

| Product Name          | Gear Ratio                  | Mass kg |
|-----------------------|-----------------------------|---------|
| <b>AZM46AK-TS</b> ◻ ◊ | <b>3.6, 7.2, 10, 20, 30</b> | 0.59    |

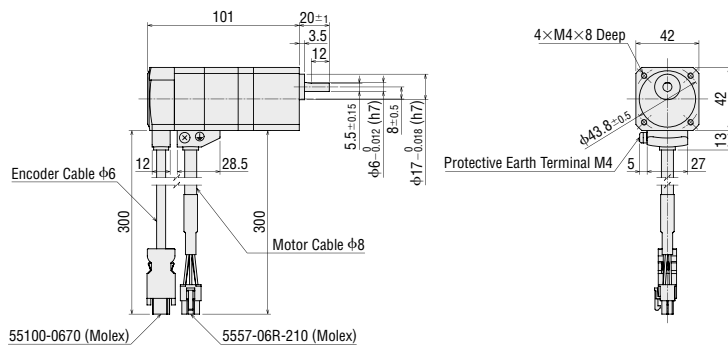

● Cable Direction

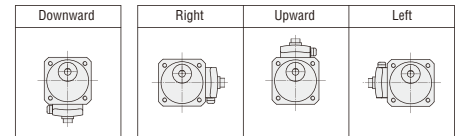

Frame Size 60 mm

| Product Name          | Gear Ratio                  | Mass kg |
|-----------------------|-----------------------------|---------|
| <b>AZM66AK-TS</b> ◻ ◊ | <b>3.6, 7.2, 10, 20, 30</b> | 1.3     |

● Installation screw: M4×60 P0.7 (4 screws included)

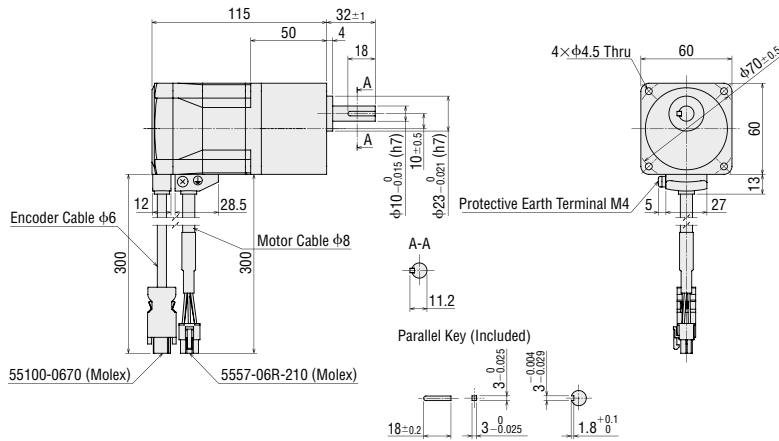

● Cable Direction

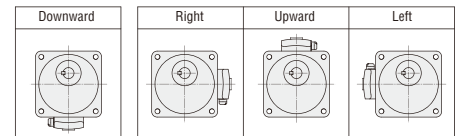

◆ **TS Geared Type with Electromagnetic Brake**  
Frame Size 42 mm

| Product Name          | Gear Ratio                  | Mass kg |
|-----------------------|-----------------------------|---------|
| <b>AZM46MK-TS</b> ◻ ◊ | <b>3.6, 7.2, 10, 20, 30</b> | 0.76    |

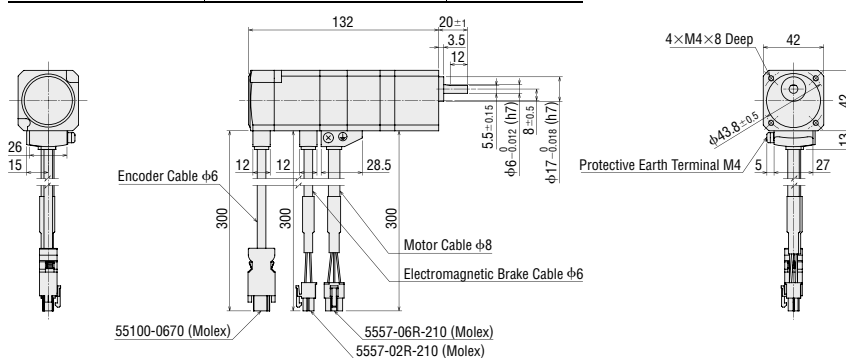

● Cable Direction

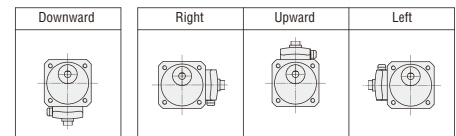

● The ◻ within the product name includes a number expressing the gear ratio.

● Either **R** (right), **U** (up) or **L** (left) indicating the cable withdrawing direction is entered where the box ◊ is located within the product name. For downward direction no letter is entered in the box ◊.

### Frame Size 60 mm

| Product Name        | Gear Ratio                  | Mass kg |
|---------------------|-----------------------------|---------|
| <b>AZM66MK-TS</b> ◊ | <b>3.6, 7.2, 10, 20, 30</b> | 1.7     |

● Installation screw: M4×60 P0.7 (4 screws included)

### ● Cable Direction

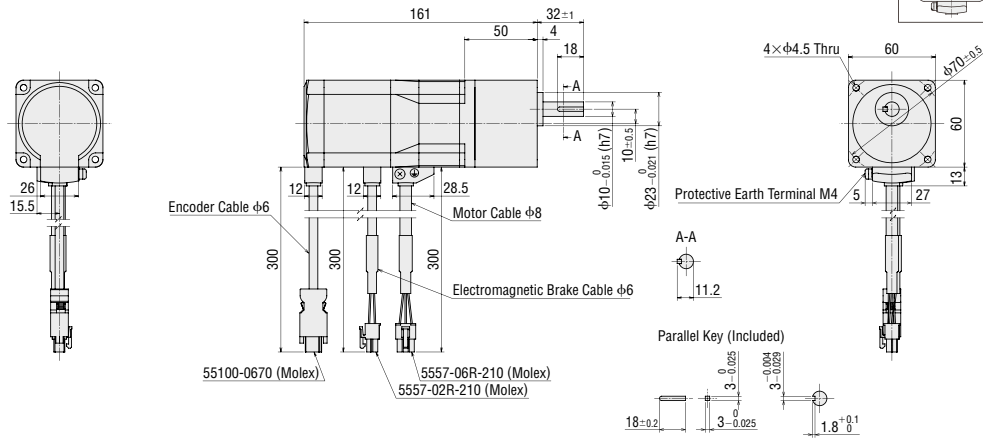
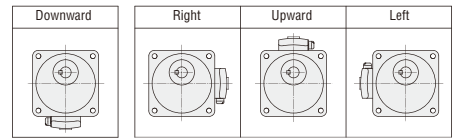

### ◊ FC Geared Type

#### Frame Size 42 mm Cable Withdrawing Direction Up

| Product Name          | Gear Ratio             | Mass kg |
|-----------------------|------------------------|---------|
| <b>AZM46AK-FC</b> ◻UA | <b>7.2, 10, 20, 30</b> | 0.79    |

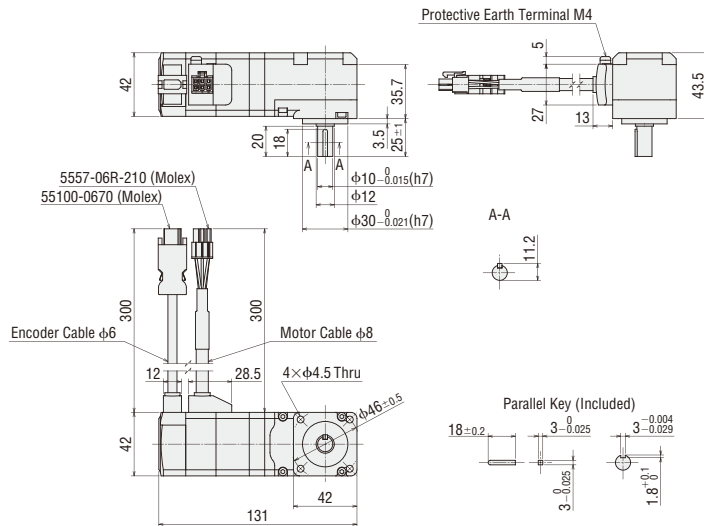

#### Frame Size 42 mm Cable Withdrawing Direction Down

| Product Name          | Gear Ratio             | Mass kg |
|-----------------------|------------------------|---------|
| <b>AZM46AK-FC</b> ◻DA | <b>7.2, 10, 20, 30</b> | 0.79    |

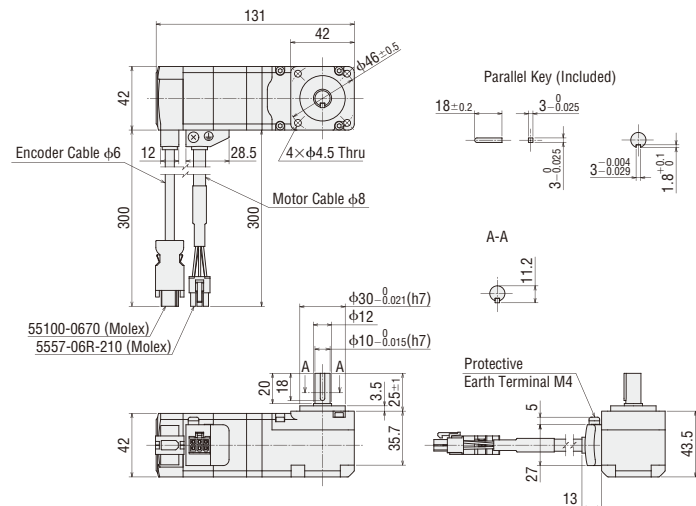

● The ◻ within the product name includes a number expressing the gear ratio.

● Either R (right), U (up) or L (left) indicating the cable withdrawing direction is entered where the box ◊ is located within the product name. For downward direction no letter is entered in the box ◊

### Frame Size 60 mm Cable Withdrawing Direction Up

| Product Name                  | Gear Ratio             | Mass kg |
|-------------------------------|------------------------|---------|
| <b>AZM66AK-FC</b> ■ <b>UA</b> | <b>7.2, 10, 20, 30</b> | 1.8     |

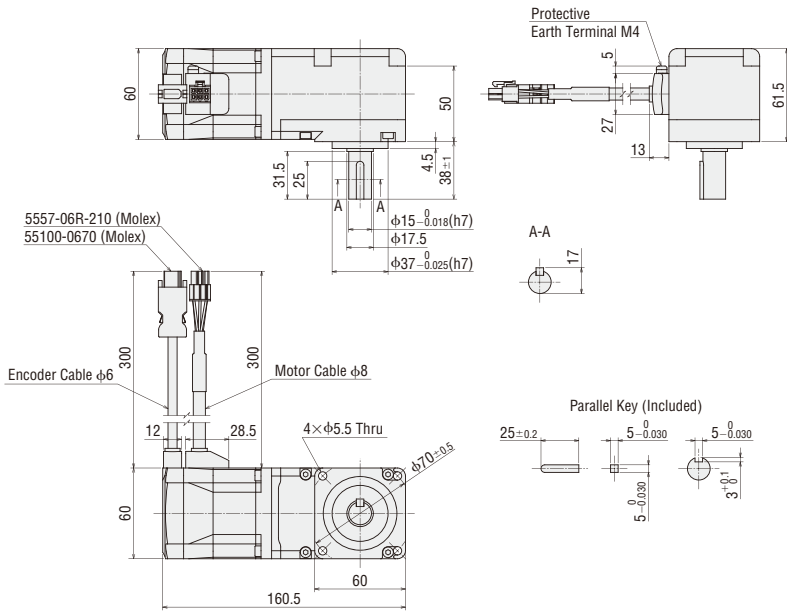

### Frame Size 60 mm Cable Withdrawing Direction Down

| Product Name                  | Gear Ratio             | Mass kg |
|-------------------------------|------------------------|---------|
| <b>AZM66AK-FC</b> ■ <b>DA</b> | <b>7.2, 10, 20, 30</b> | 1.8     |

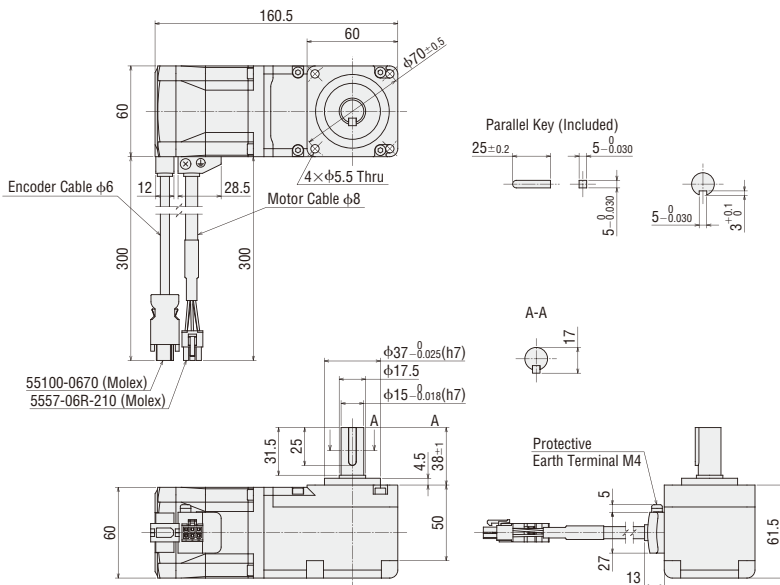

● The ■ within the product name includes a number expressing the gear ratio.

Features

System Configuration

Product Line

Specifications and Features

Dimensions

Connection and Operation

System Configuration

Product Line

Specifications and Features

DC Input

Dimensions

Connection and Operation

Multiaxis Driver

Accessories

◇ FC Geared Type with Electromagnetic Brake  
 Frame Size 42 mm Cable Withdrawing Direction Up

| Product Name                  | Gear Ratio             | Mass kg |
|-------------------------------|------------------------|---------|
| <b>AZM46MK-FC</b> ■ <b>UA</b> | <b>7.2, 10, 20, 30</b> | 0.96    |

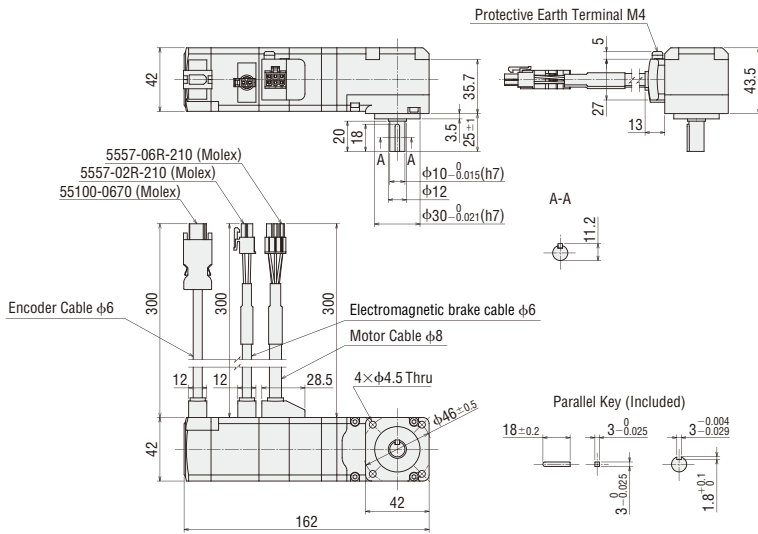

Frame Size 42 mm Cable Withdrawing Direction Down

| Product Name                  | Gear Ratio             | Mass kg |
|-------------------------------|------------------------|---------|
| <b>AZM46MK-FC</b> ■ <b>DA</b> | <b>7.2, 10, 20, 30</b> | 0.96    |

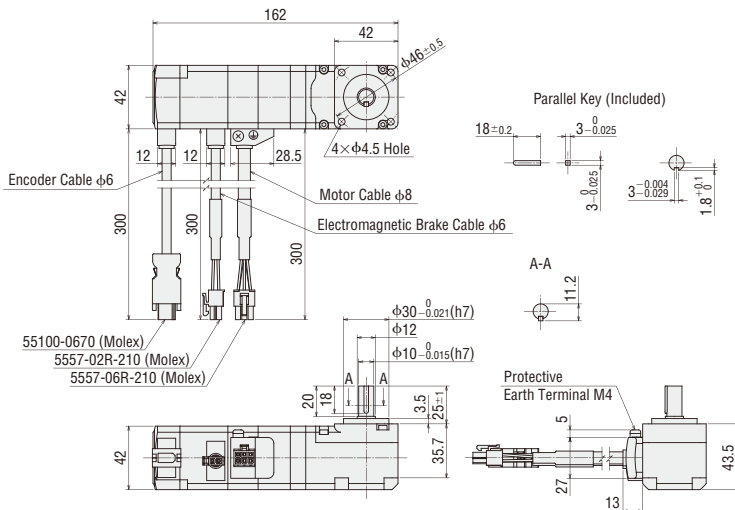

● The ■ within the product name includes a number expressing the gear ratio.

### Frame Size 60 mm Cable Withdrawing Direction Up

| Product Name        | Gear Ratio             | Mass kg |
|---------------------|------------------------|---------|
| <b>AZM66MK-FCUA</b> | <b>7.2, 10, 20, 30</b> | 2.2     |

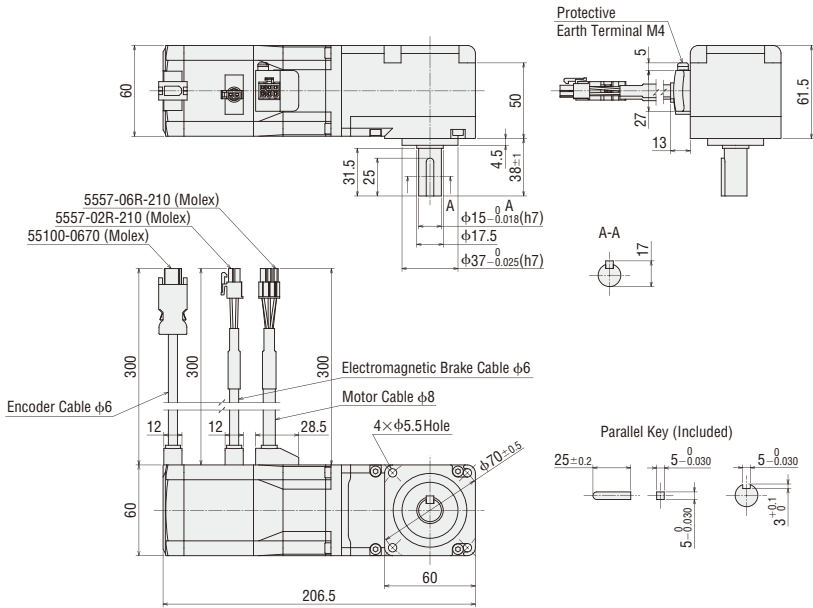

### Frame Size 60 mm Cable Withdrawing Direction Down

| Product Name        | Gear Ratio             | Mass kg |
|---------------------|------------------------|---------|
| <b>AZM66AK-MCDA</b> | <b>7.2, 10, 20, 30</b> | 2.2     |

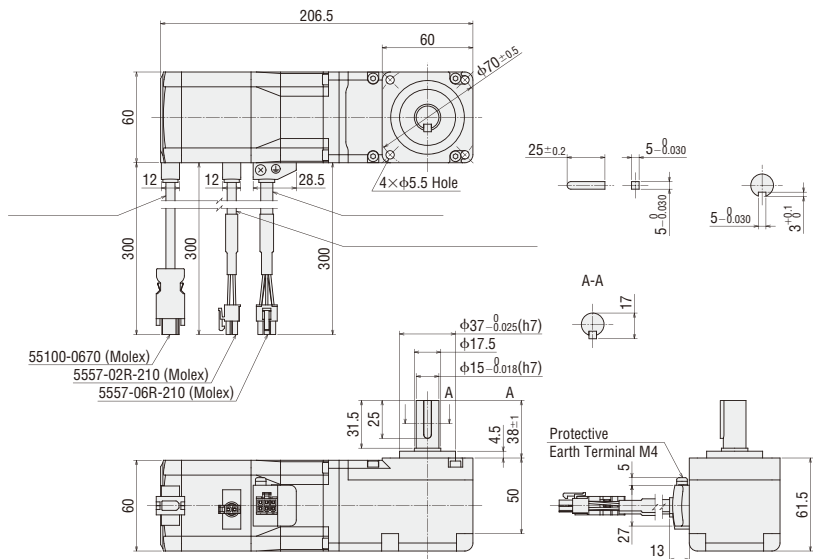

|          |                      |              |                             |            |                          |                      |              |                             |            |                          |                   |             |
|----------|----------------------|--------------|-----------------------------|------------|--------------------------|----------------------|--------------|-----------------------------|------------|--------------------------|-------------------|-------------|
| Features | System Configuration | Product Line | Specifications and Features | Dimensions | Connection and Operation | System Configuration | Product Line | Specifications and Features | Dimensions | Connection and Operation | Multi-axis Driver | Accessories |
|          |                      |              | AC Input                    |            |                          |                      |              |                             | DC Input   |                          |                   |             |

◆ **PS Geared Type**

Frame Size 42 mm

| Product Name        | Gear Ratio        | L     | Mass kg |
|---------------------|-------------------|-------|---------|
| <b>AZM46AK-PS</b> ■ | <b>5, 7.2, 10</b> | 98    | 0.64    |
|                     | <b>25, 36, 50</b> | 121.5 | 0.79    |

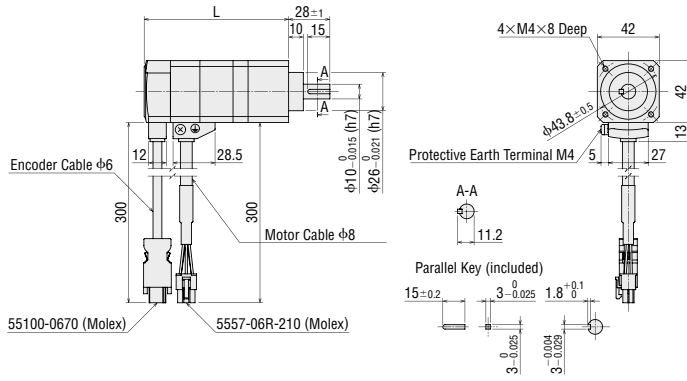

Frame Size 60 mm

| Product Name        | Gear Ratio        | L   | Mass kg |
|---------------------|-------------------|-----|---------|
| <b>AZM66AK-PS</b> ■ | <b>5, 7.2, 10</b> | 104 | 1.3     |
|                     | <b>25, 36, 50</b> | 124 | 1.6     |

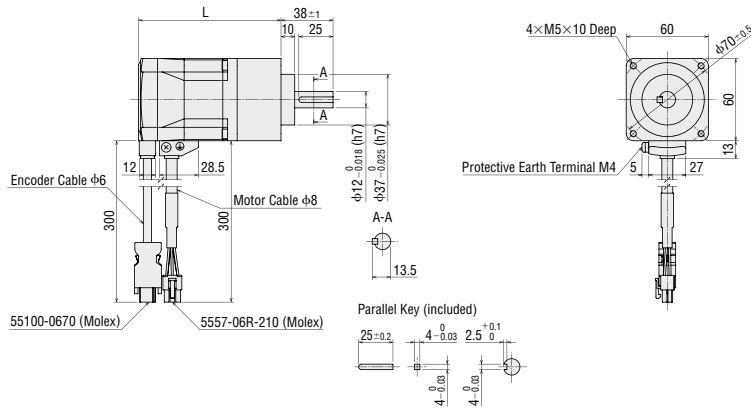

◆ **PS Geared Type with Electromagnetic Brake**

Frame Size 42 mm

| Product Name        | Gear Ratio        | L   | Mass kg |
|---------------------|-------------------|-----|---------|
| <b>AZM46MK-PS</b> ■ | <b>5, 7.2, 10</b> | 129 | 0.81    |
|                     | <b>25, 36, 50</b> | 152 | 0.96    |

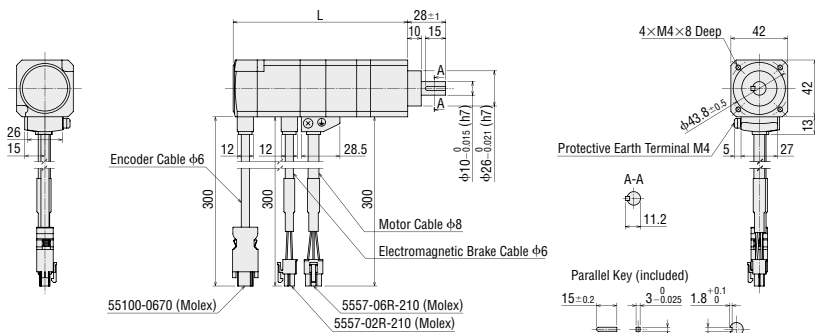

● The ■ within the product name includes a number expressing the gear ratio.

Frame Size 60 mm

| Product Name      | Gear Ratio        | L   | Mass kg |
|-------------------|-------------------|-----|---------|
| <b>AZM66MK-PS</b> | <b>5, 7.2, 10</b> | 150 | 1.7     |
|                   | <b>25, 36, 50</b> | 170 | 2.0     |

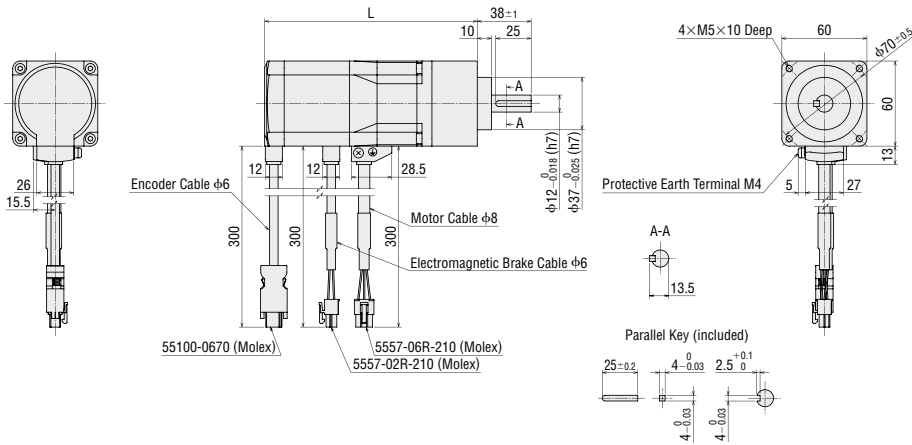

◆ HPG Geared Type Shaft Output Type  
Frame Size 40 mm

| Product Name      | Gear Ratio  | Mass kg |
|-------------------|-------------|---------|
| <b>AZM46AK-HP</b> | <b>5, 9</b> | 0.71    |

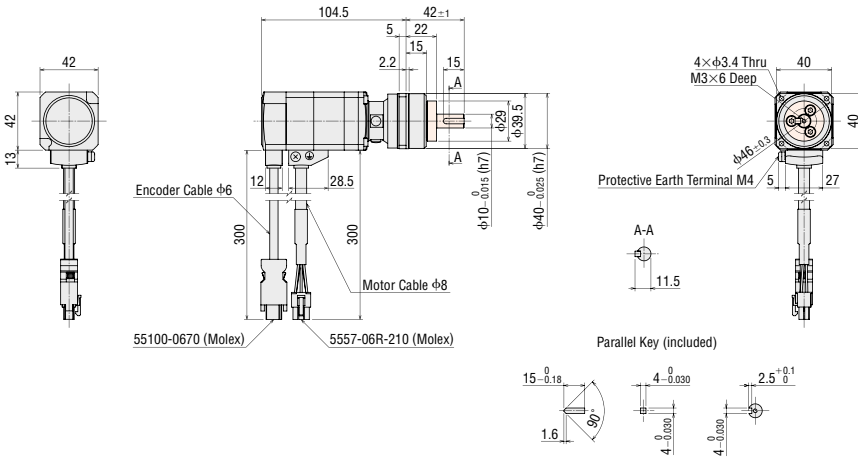

Frame Size 60 mm

| Product Name      | Gear Ratio   | Mass kg |
|-------------------|--------------|---------|
| <b>AZM66AK-HP</b> | <b>5, 15</b> | 1.9     |

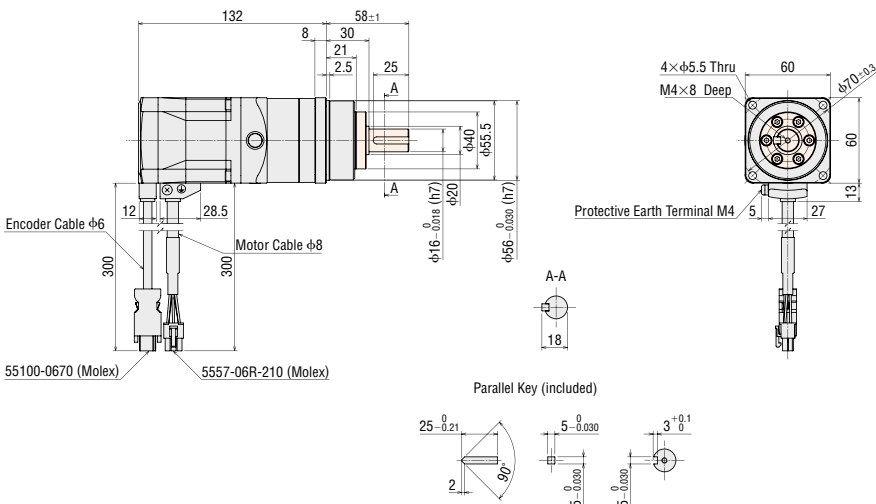

- The coloured part  of the outline drawing is the rotation section.
- The  within the product name includes a number expressing the gear ratio.

◇ **HPG Geared Type Flange Output Type**  
**Frame Size 40 mm**

| Product Name         | Gear Ratio  | Mass kg |
|----------------------|-------------|---------|
| <b>AZM46AK-HP</b> ■F | <b>5, 9</b> | 0.66    |

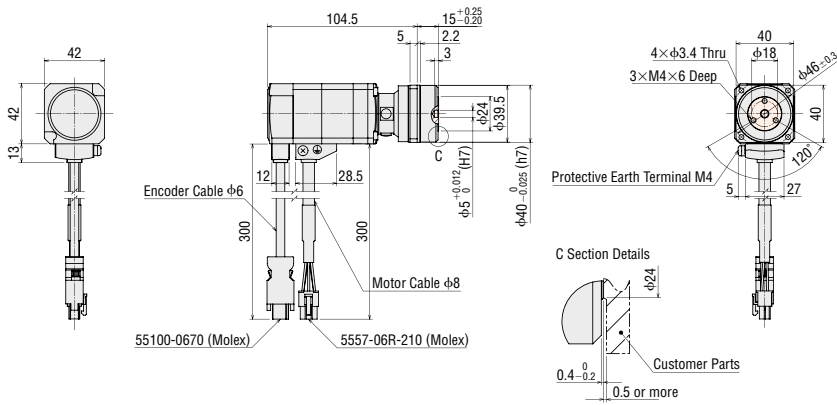

**Frame Size 60 mm**

| Product Name         | Gear Ratio   | Mass kg |
|----------------------|--------------|---------|
| <b>AZM66AK-HP</b> ■F | <b>5, 15</b> | 1.8     |

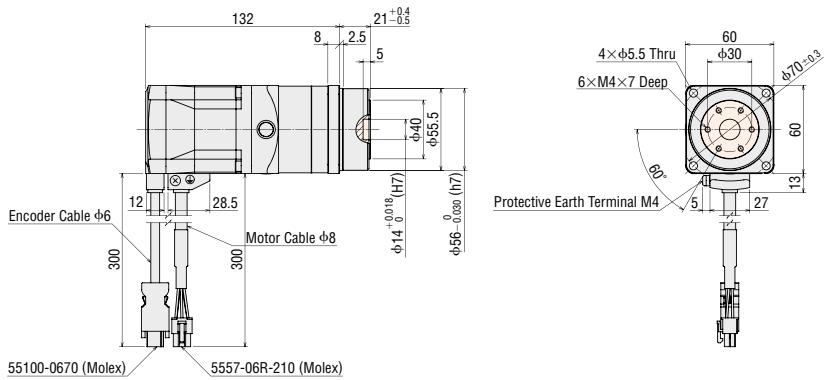

◇ **HPG Geared Type with Electromagnetic Brake Shaft Output Type**  
**Frame Size 40 mm**

| Product Name        | Gear Ratio  | Mass kg |
|---------------------|-------------|---------|
| <b>AZM46MK-HP</b> ■ | <b>5, 9</b> | 0.88    |

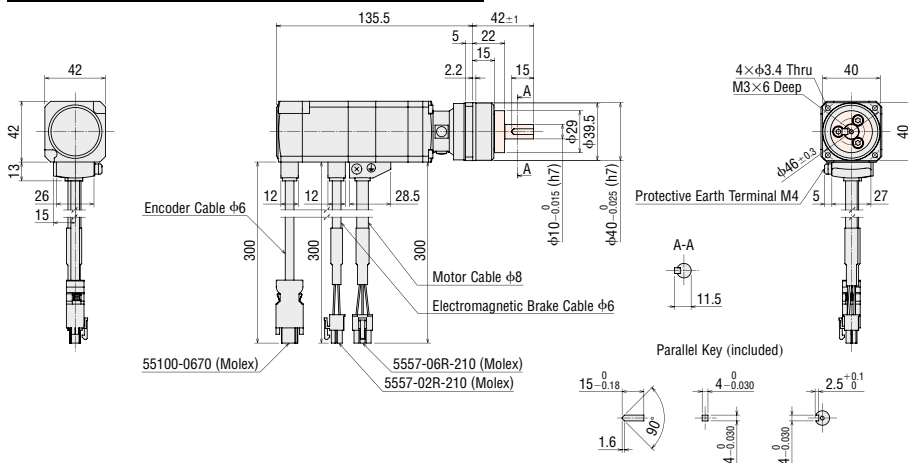

- The coloured part ■ of the outline drawing is the rotation section.
- The ■ within the product name includes a number expressing the gear ratio.



Frame Size 60 mm

| Product Name      | Gear Ratio   | Mass kg |
|-------------------|--------------|---------|
| <b>AZM66MK-HP</b> | <b>5, 15</b> | 2.3     |

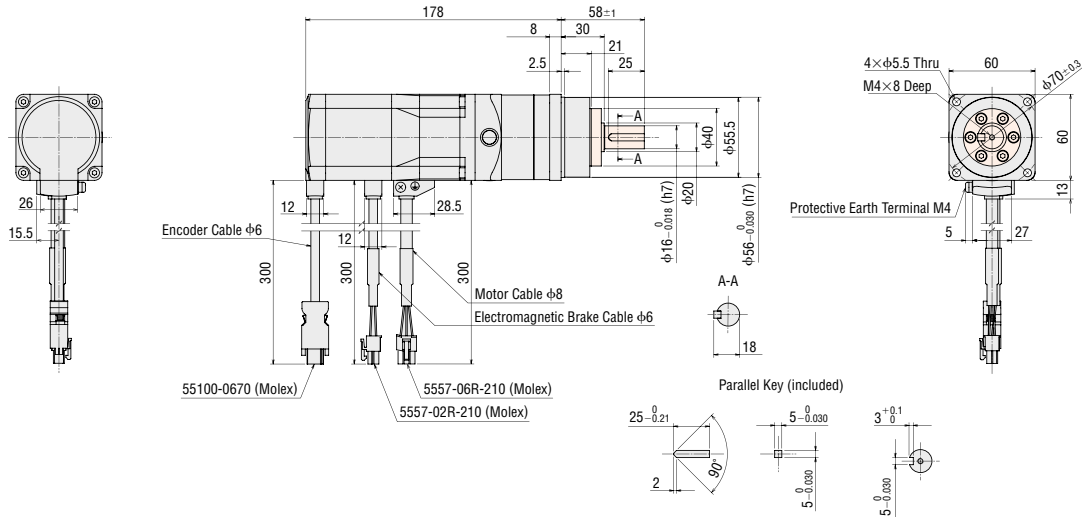

◆ HPG Geared Type with Electromagnetic Brake Flange Output Type  
Frame Size 40 mm

| Product Name        | Gear Ratio  | Mass kg |
|---------------------|-------------|---------|
| <b>AZM46MK-HP</b> F | <b>5, 9</b> | 0.83    |

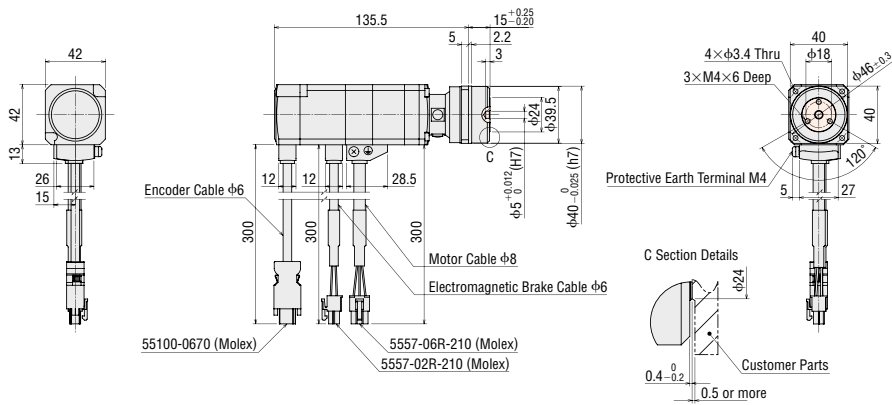

Frame Size 60 mm

| Product Name        | Gear Ratio   | Mass kg |
|---------------------|--------------|---------|
| <b>AZM66MK-HP</b> F | <b>5, 15</b> | 2.2     |

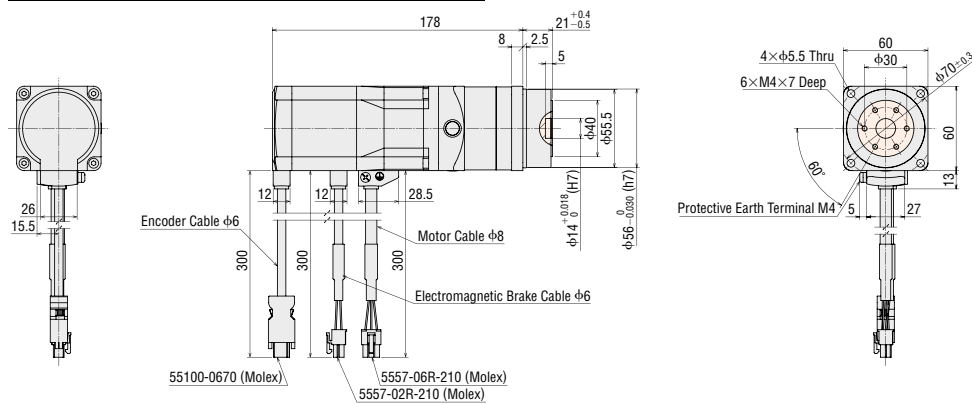

● The coloured part  of the outline drawing is the rotation section.  
● The    within the product name includes a number expressing the gear ratio.

### ◇ Harmonic Geared Type

#### Frame Size 42 mm

| Product Name   | Gear Ratio     | Mass kg |
|--|----------------|---------|
| <b>AZM46AK-HS</b> <span style="background-color: #e0e0e0; border: 1px solid black; padding: 0 2px;"> </span> | <b>50, 100</b> | 0.65    |

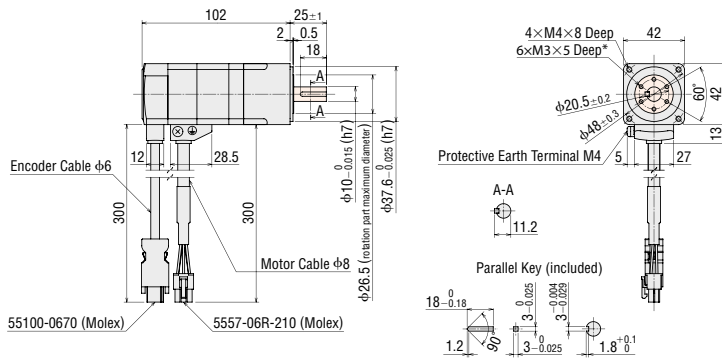

\*The position of the output shaft relative to the screw holes on the rotating part cannot be specified. Adjust the position via the size of the screw holes on the load installation surface.

#### Frame Size 60 mm

| Product Name   | Gear Ratio     | Mass kg |
|--|----------------|---------|
| <b>AZM66AK-HS</b> <span style="background-color: #e0e0e0; border: 1px solid black; padding: 0 2px;"> </span> | <b>50, 100</b> | 1.4     |

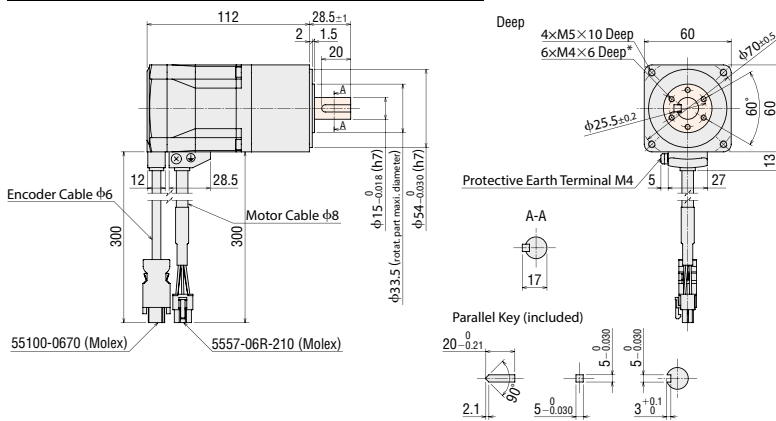

\*The position of the output shaft relative to the screw holes on the rotating part cannot be specified. Adjust the position via the size of the screw holes on the load installation surface.

- The coloured part   of the outline drawing is the rotation section.
- The   within the product name includes a number expressing the gear ratio.

## ◇ Harmonic Geared Type with Electromagnetic Brake

### Frame Size 42 mm

| Product Name      | Gear Ratio     | Mass kg |
|-------------------|----------------|---------|
| <b>AZM46MK-HS</b> | <b>50, 100</b> | 0.82    |

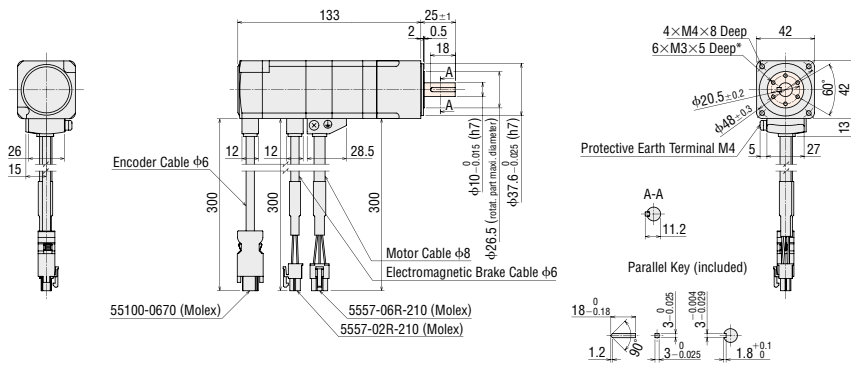

\*The position of the output shaft relative to the screw holes on the rotating part cannot be specified. Adjust the position via the size of the screw holes on the load installation surface.

### Frame Size 60 mm

| Product Name      | Gear Ratio     | Mass kg |
|-------------------|----------------|---------|
| <b>AZM66MK-HS</b> | <b>50, 100</b> | 1.8     |

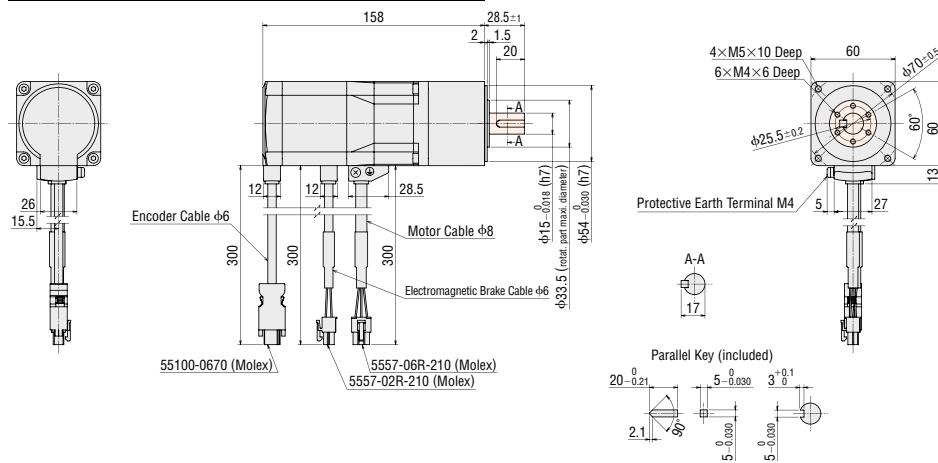

\*The position of the output shaft relative to the screw holes on the rotating part cannot be specified. Adjust the position via the size of the screw holes on the load installation surface.

- The coloured part  of the outline drawing is the rotation section.
- The  within the product name includes a number expressing the gear ratio.

● Drivers

◇ Built-in Controller Type, Pulse-Input Type with RS-485 Communication

Driver Product Name: **AZD-KD, AZD-KX**

Mass: 0.15kg

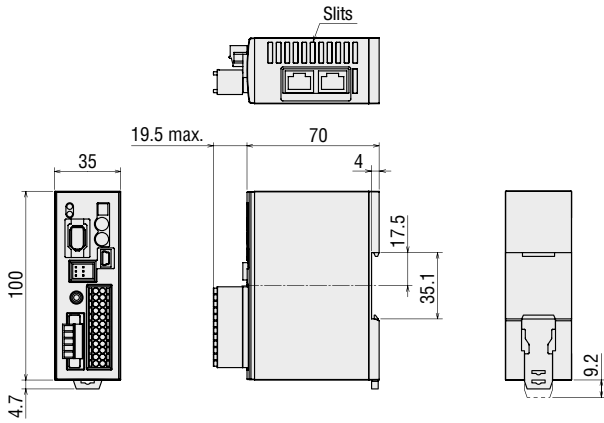

● Accessories

Connector form in power/electromagnetic brake connections (CN1)

Connector: MC1,5/5-STF-3,5  
(PHOENIX CONTACT GmbH & Co. KG)

Connector for Input/Output Signal (CN4)

Connector: DFMC1,5/12-ST-3,5  
(PHOENIX CONTACT GmbH & Co. KG)

◇ Pulse-Input Type

Driver Product Name: **AZD-K**

Mass: 0.15kg

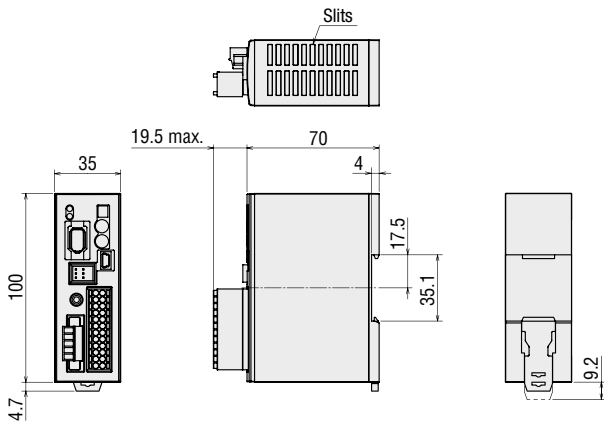

● Accessories

Connector form in power/electromagnetic brake connections (CN1)

Connector: MC1,5/5-STF-3,5  
(PHOENIX CONTACT GmbH & Co. KG)

Connector for Input/Output Signal (CN4)

Connector: DFMC1,5/12-ST-3,5  
(PHOENIX CONTACT GmbH & Co. KG)

● Cable for Motor (sold separately), Cable for Encoder (sold separately), Cable for Electromagnetic Brake (sold separately)

● Only products with included connection cables

[AZ14, AZ15, AZ24, AZ26 use]

◇ Cable for Motor

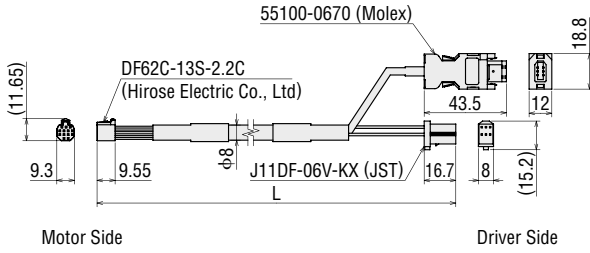

[AZ46, AZ48, AZ66, AZ69 use]

◇ Cable for Motor

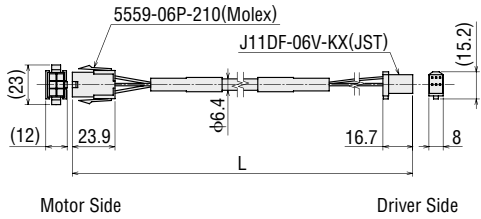

◇ Cable for Encoder

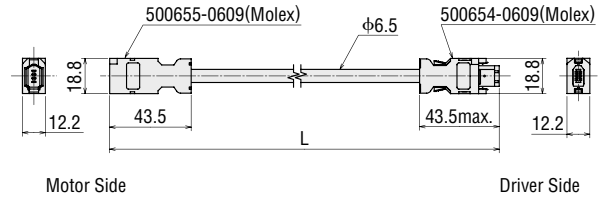

◇ Cable for Electromagnetic Brake (Only for electromagnetic brake products)

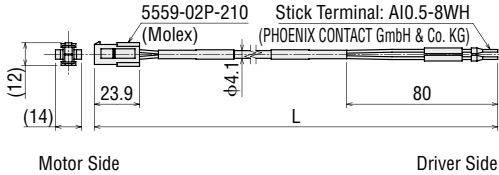

\*The length L (m) is specified where L is located in the dimensions in "Product Line" on page 71.

Notes

● The motor cable and the electromagnetic brake cable coming out of the motor cannot be connected directly to the driver. For connection to the driver use the accessory connection cable (sold separately) or the connection cable which is included to the product (for products with included cable).

|          |                      |              |                             |            |                          |                      |              |                             |            |                          |                  |             |
|----------|----------------------|--------------|-----------------------------|------------|--------------------------|----------------------|--------------|-----------------------------|------------|--------------------------|------------------|-------------|
| Features | System Configuration | Product Line | Specifications and Features | Dimensions | Connection and Operation | System Configuration | Product Line | Specifications and Features | Dimensions | Connection and Operation | Multiaxis Driver | Accessories |
|          |                      |              | AC Input                    |            |                          |                      |              |                             | DC Input   |                          |                  |             |

## Connection and Operation (Built-in Controller Type)

### Name and Functions of Driver Parts

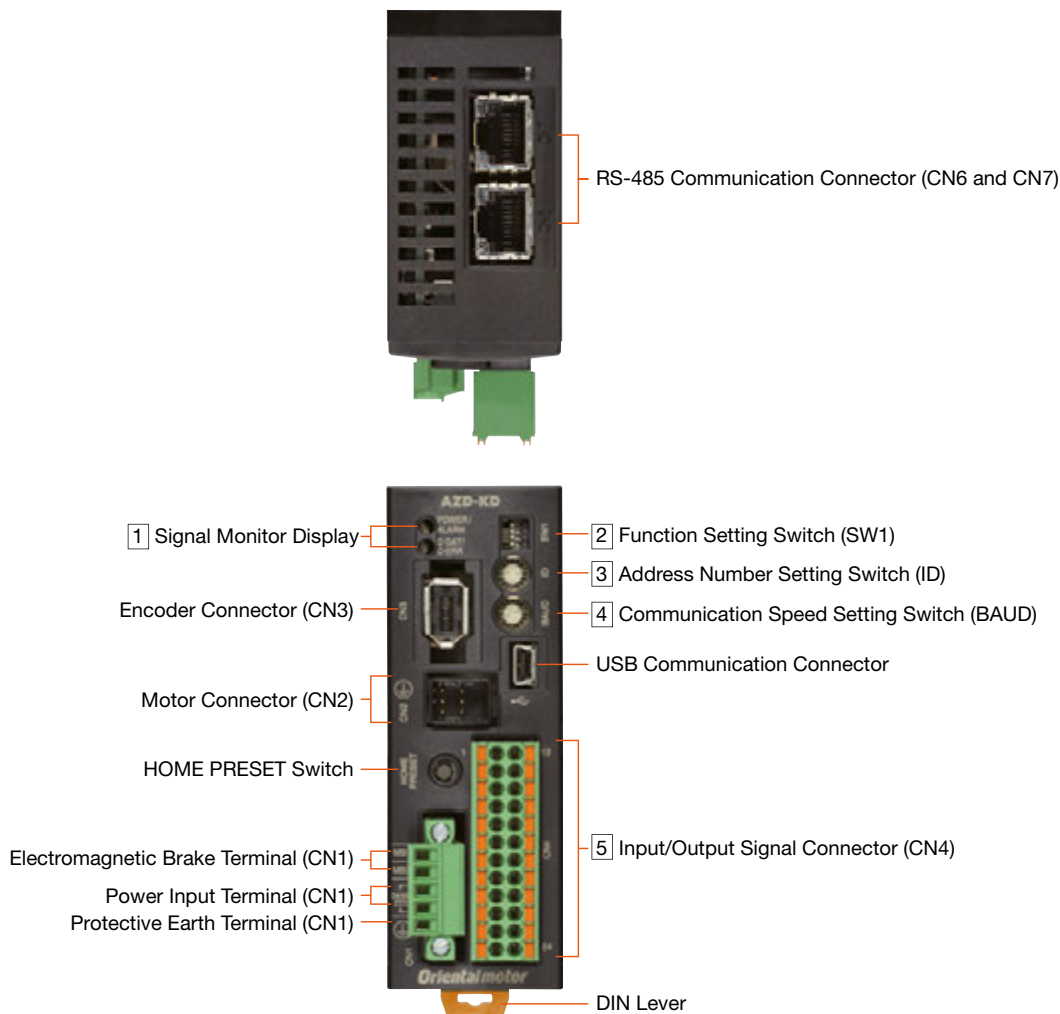

#### 1 Signal Monitor Display

##### ◇ LED Display

| Display | Colour | Function                    | When Activated                                  |
|---------|--------|-----------------------------|---|
| POWER   | Green  | Power Display               | When power is on.                               |
| ALARM   | Red    | Alarm Display               | Blinks when protective functions are activated. |
| C-DAT   | Green  | Communication Display       | When communication data is received or sent.    |
| C-ERR   | Red    | Communication Error Display | When there is an error with communication data. |

#### 2 Function Setting Switch

| Display | No. | Function  |
|---------|-----|---|
| SW1     | 1   | This sets the address number in combination with the address number setting switch (ID) (Factory Setting: OFF).                               |
|         | 2   | Set the RS-485 communication protocol.<br>Factory setting:<br>Built-in Controller Type: OFF<br>Pulse-Input Type with RS-485 Communication: ON |
|         | 3   | Set the RS-485 communication terminal resistor (120Ω) (Factory Setting: OFF).   |
|         | 4   | OFF: no terminal resistor,<br>ON: terminal resistor connected.  |

\*Please use the same settings for both No. 3 and No. 4.

#### 3 Address Number Setting Switch (ID)

| Display | Function   |
|---------|--|
| ID      | Set this when RS-485 communication is used. Set the axis number.<br>Factory setting:<br>Built-in Controller Type: 0<br>Pulse-Input Type with RS-485 Communication: 1 |

#### 4 Communication Speed Setting Switch

| Display | Function   |
|---------|--|
| BAUD    | Set this when RS-485 communication is used. Set the baud rate.<br>Factory setting:<br>Built-in Controller Type: 7<br>Pulse Input Type with RS-485 Communication: 4 |

#### ◇ Settings of the RS-485 Communication Speed

| No. | Baud Rate (bps)   |
|-----|-------------------|
| 0   | 9600              |
| 1   | 19200             |
| 2   | 38400             |
| 3   | 57600             |
| 4   | 115200            |
| 5   | 230400            |
| 6   | Not used          |
| 7   | Network Converter |
| 8-F | Not used          |

#### 5 Input/Output Signal Connector (CN4)

For the Pulse-Input Type with RS-485 Communication pin No. 1, 2, 13 and 14 are for pulse input. For connecting to a programmable controller refer to page 108-109 of the Pulse-Input Type.

| Display | Pin Number | Driver Type                                | Signal Name     | Content  |   |
|---------|------------|--|-----------------|--|---|
| CN4     | 1          | Built-In Controller Type                   | IN0             | START  | This signal is used to start positioning operation.   |
|         |            | Pulse-Input Type with RS-485 Communication | CW+*<br>[PLS+]  | CW Pulse Input+<br>[Pulse Input+]                          | Pulse signal for motor operation in CW direction with 2 pulse input method. The brackets [ ] show the content when using 1 pulse input method.  |
|         | 2          | Built-In Controller Type                   | IN2             | M1   | Use 3 bits (M0, M1 and M2) to select the operating data number.   |
|         |            | Pulse-Input Type with RS-485 Communication | CCW+*<br>[DIR+] | CCW Pulse Input+<br>[Rotation Direction Input+]            | Pulse signal for motor operation in CCW direction with 2 pulse input method. The brackets [ ] show the content when using 1 pulse input method. |
|         | 3          | Common                                     | IN4             | ZHOME  | Move to the home position set by the HOME PRESET switch.  |
|         | 4          | Common                                     | IN6             | STOP   | Stop the motor.   |
|         | 5          | Common                                     | IN-COM [0-7]*   | IN0-IN7 Input Common                                       |   |
|         | 6          | Common                                     | IN8             | FW-JOG   | Start the JOG operation.  |
|         | 7          | Common                                     | OUT0            | HOME-END   | Output when the home position is fixed and the high speed return-to-home operation is complete.   |
|         | 8          | Common                                     | OUT2            | PLS-RDY  | Not used.   |
|         | 9          | Common                                     | OUT4            | MOVE   | Output when the motor is operating.   |
|         | 10         | Common                                     | OUT-COM*        | Output Common  |   |
|         | 11         | Common                                     | ASG+            | A-Phase Output+  |   |
|         | 12         | Common                                     | BSG+            | B-Phase Output+  |   |
|         | 13         | Built-In Controller Type                   | IN1             | M0   | Use 3 bits (M0, M1 and M2) to select the operating data number.   |
|         |            | Pulse-Input Type with RS-485 Communication | CW-*<br>[PLS-]  | CW Pulse Input-<br>[Pulse Input-]                          | Pulse signal for motor operation in CW direction with 2 pulse input method. The brackets [ ] show the content when using 1 pulse input method.  |
|         | 14         | Built-In Controller Type                   | IN3             | M2   | Use 3 bits (M0, M1 and M2) to select the operating data number.   |
|         |            | Pulse-Input Type with RS-485 Communication | CCW-*<br>[DIR-] | CCW Pulse Input+<br>[Rotation Direction Input+]            | Pulse signal for motor operation in CCW direction with 2 pulse input method. The brackets [ ] show the content when using 1 pulse input method. |
|         | 15         | Common                                     | IN5             | FREE   | Stop motor excitation.  |
|         | 16         | Common                                     | IN7             | ALM-RST  | Reset the alarm.  |
|         | 17         | Common                                     | IN-COM [8-9]*   | IN8, IN9 Input Common                                      |   |
|         | 18         | Common                                     | IN9             | RV-JOG   | Start the JOG operation.  |
|         | 19         | Common                                     | OUT1            | IN-POS   | Output when the motor operation is complete.  |
|         | 20         | Common                                     | OUT3            | READY  | Output when the driver is prepared for operation.   |
| 21      | Common     | OUT5                                       | ALM-B           | Outputs the alarm status for the driver (normally closed). |   |
| 22      | Common     | GND*1                                      | Ground          |  |   |
| 23      | Common     | ASG-                                       | A-Phase Output- |  |   |
| 24      | Common     | BSG-                                       | B-Phase Output- |  |   |

● Functions to assign can be set by specifying parameters. Initial values are shown above. Refer to the AZ Series Function Edition operating manual.

\*1 The initial value setting cannot be changed.

## ● Connection Diagram

### ◇ Connection to Peripheral Equipment

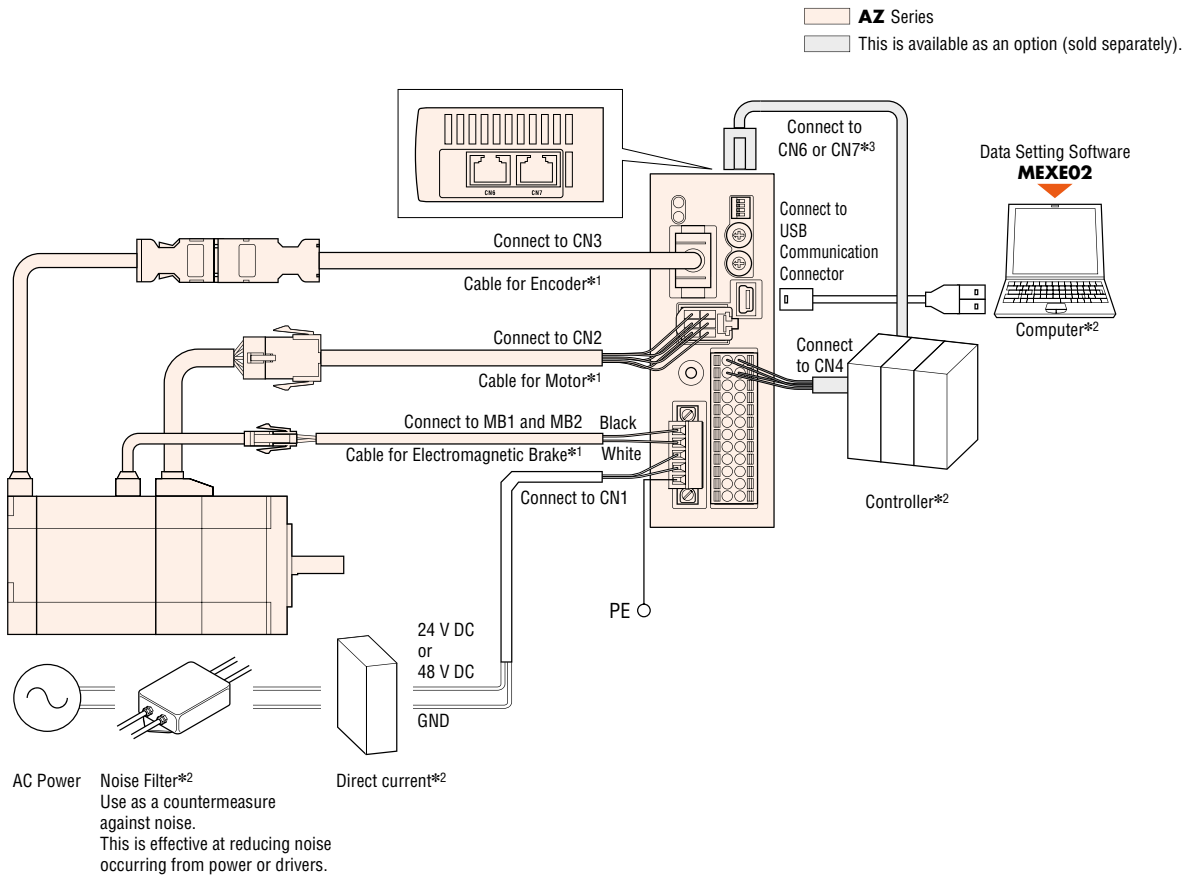

\*1 When wiring the motor and the driver, keep a max. distance of 20 m.

\*2 Prepared by the customer.

\*3 When controlling with RS-485 communications, connect to the controller.

### ◇ USB Cable Connection

The computer on which the data setting software **MEXEO2** is installed and driver are connected with a USB cable. Use the following specifications for the USB cable.

|               |                       |
|---------------|-----------------------|
| Specification | USB2.0 (full speed)   |
| Cable         | Length: 3 m (or less) |
|               | Format: A-mini-B      |



◇ Connecting to a Host Controller

● Connecting to a Current Sink Output Circuit

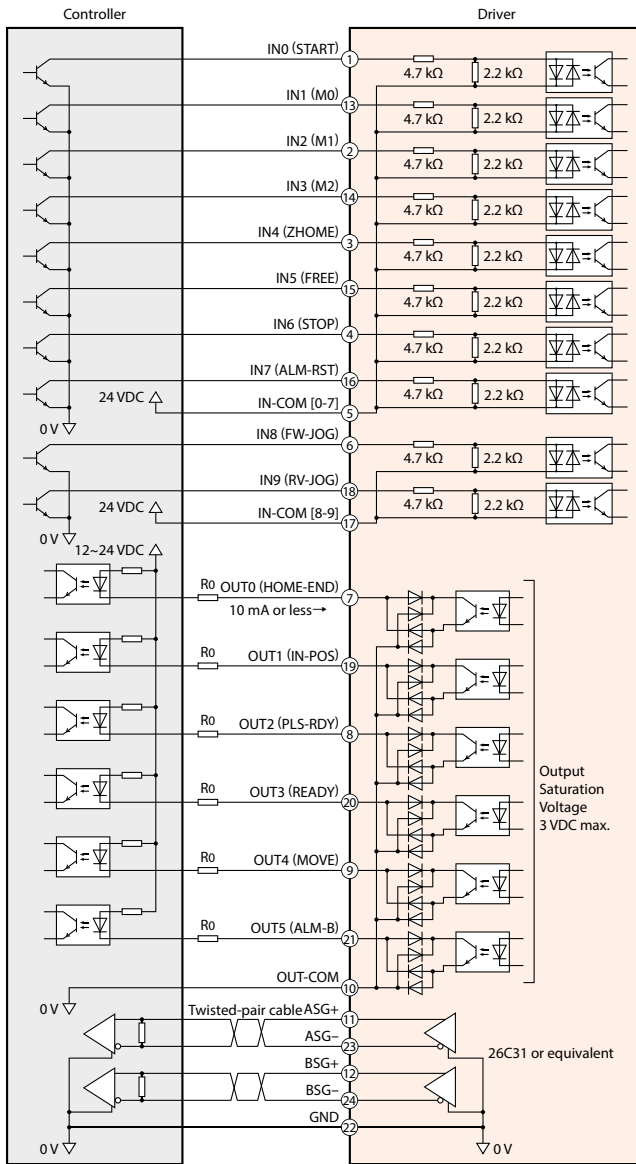

**Notes**

- For the input signal, use 24 VDC.
- For the output signal, use 12~24 VDC 10 mA or less. Where the current value exceeds 10 mA, connect an external resistor  $R_0$  to reduce the current to 10 mA or less.
- Make sure the signal line is wired at a distance of 200 mm or longer from the power lines (power supply line and motor line). Furthermore, do not insert the signal line in the same pipe as the power lines or bundle them together.
- When noise is emitted from the motor cable or power cable due to wiring or allocation and it cause a problem, use shields or ferrite cores.

● Connecting to a Current Source Output Circuit

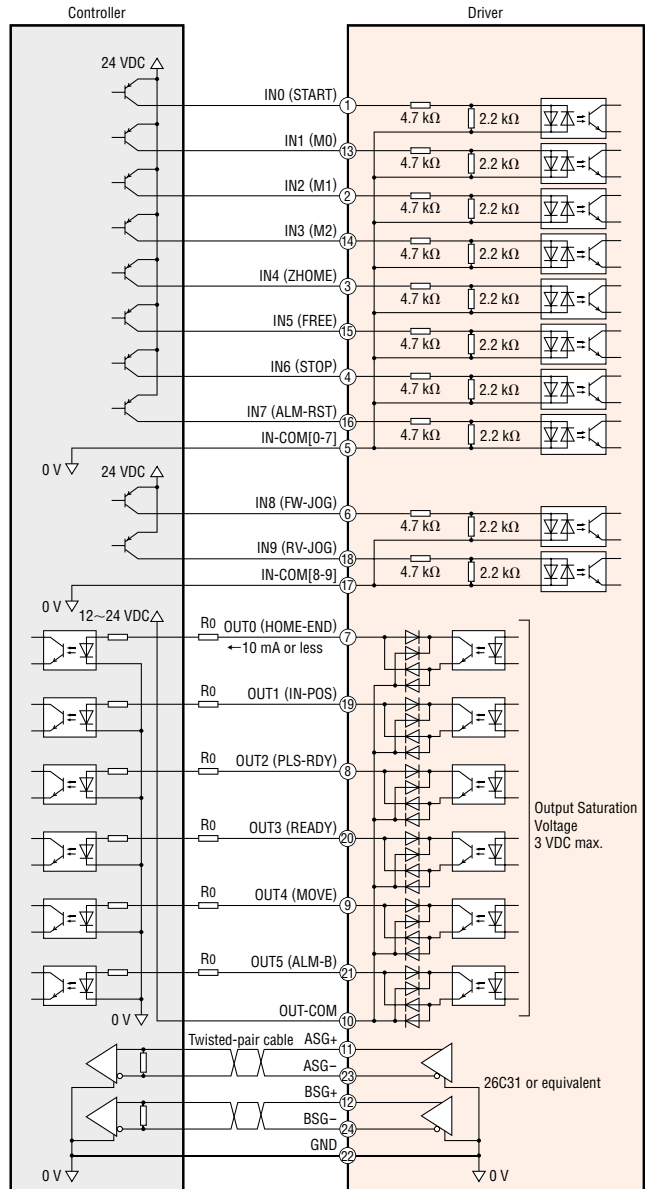

**Notes**

- For the input signal, use 24 VDC.
- For the output signal, use 12~24 VDC 10 mA or less. Where the current value exceeds 10 mA, connect an external resistor  $R_0$  to reduce the current to 10 mA or less.
- Make sure the signal line is wired at a distance of 200 mm or longer from the power line (power supply line and motor line). Furthermore, do not insert the signal line in the same pipe as the power lines or bundle them together.
- When noise is emitted from the motor cable or power cable due to wiring or allocation and it cause a problem, use shields or ferrite cores.

◇ Connecting to a Programmable Controller (Pulse-Input Type with RS-485 Communication)

The connection is the same as that of the Pulse-Input Type. See page 108-109

|                             |
|-----------------------------|
| Features                    |
| System Configuration        |
| Product Line                |
| Specifications and Features |
| AC Input                    |
| Dimensions                  |
| Connection and Operation    |
| System Configuration        |
| Product Line                |
| Specifications and Features |
| DC Input                    |
| Dimensions                  |
| Connection and Operation    |
| Multiaxis Driver            |
| Accessories                 |

## Connection and Operation (Pulse-Input Type)

### Names and Functions of Driver Parts

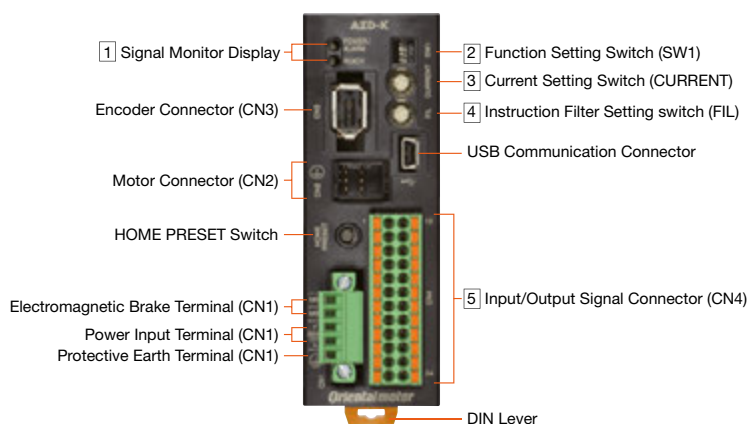

#### 1 Signal Monitor Display

##### ◇ LED Display

| Display | Colour | Function      | When Activated                                  |
|---------|--------|---------------|---|
| POWER   | Green  | Power Display | When power is on.                               |
| ALARM   | Red    | Alarm Display | Blinks when protective functions are activated. |
| READY   | Green  | READY output  | When READY output is set to ON                  |

#### 2 Function Setting Switch

| Display | No.  | Function  |
|---------|------|---|
| SW1     | 1    | Set the resolution for each motor output axis rotation (Factory Setting : OFF [1000p/r]).                           |
|         | 2    | Set the pulse input format to 1 pulse input mode or 2 pulse input mode. (Factory Setting: OFF [2 pulse input mode]) |
|         | 3, 4 | Not used  |

#### 3 Current Setting Switch

| Display | Function  |
|---------|---|
| CURRENT | Set basic current that is the base for the operation current and stop current (Factory Setting: F). |

#### 4 Command Filter Setting Switch

| Display | Function   |
|---------|--|
| FIL     | Adjust the responsiveness of the motor (Factory Setting: 1). |

#### 5 Input/Output Signal Connector (CN4)

| Display | Pin Number | Signal Name    | Content  |
|---------|------------|----------------|--|
| CN5     | 1          | CW+[PLS+]*1    | CW pulse input+[pulse input+] Pulse signal for motor operation in CW direction with 2 pulse input method. The brackets [ ] show the content when using 1 pulse input method.                 |
|         | 2          | CCW+[DIR+]*1   | CCW pulse input+[rotation direction input+] Pulse signal for motor operation in CCW direction with 2 pulse input method. The brackets [ ] show the content when using 1 pulse input method.  |
|         | 3          | IN4            | ZHOME Move to the home position set with the HOME PRESET switch.   |
|         | 4          | IN6            | STOP Stop the motor.   |
|         | 5          | IN-COM [4-7]*1 | IN4-IN7 input common   |
|         | 6          | IN8            | FW-JOG Start JOG operation.  |
|         | 7          | OUT0           | HOME-END Output when determining the home position or completing high speed return-to-home operation.  |
|         | 8          | OUT2           | PLS-RDY Output when the pulse input preparation is complete.   |
|         | 9          | OUT4           | MOVE Output while operating the motor.   |
|         | 10         | OUT-COM*1      | Output common  |
|         | 11         | ASG+           | A phase pulse output+  |
|         | 12         | BSG+           | B phase pulse output+  |
|         | 13         | CW-[PLS-]*1    | CW pulse input-[pulse input-] Pulse signal for motor operation in CW direction with 2 pulse input method. The brackets [ ] show the content when using 1 pulse input method.                 |
|         | 14         | CCW-[DIR-]*1   | CCW pulse input-[rotation direction input -] Pulse signal for motor operation in CCW direction with 2 pulse input method. The brackets [ ] show the content when using 1 pulse input method. |
|         | 15         | IN5            | FREE The motor is set to non-excitation.   |
|         | 16         | IN7            | ALM-RST Reset the alarm.   |
|         | 17         | IN-COM [8-9]*1 | IN8, IN9 input common  |
|         | 18         | IN9            | RV-JOG Start JOG operation.  |
|         | 19         | OUT1           | IN-POS Output when the motor operation is complete.  |
|         | 20         | OUT3           | READY Outputs when the driver is ready for operation.  |
|         | 21         | OUT5           | ALM-B Output the driver alarm state (normal close).  |
|         | 22         | GND*1          | Ground   |
|         | 23         | ASG-           | A phase pulse output-  |
|         | 24         | BSG-           | B phase pulse output-  |

Assigned functions are set by means of the parameter settings. The above is the initial value. For details, refer to the User's Manual.

\*1 The initial value setting cannot be changed.

● Connection Diagram

◇ Connection to Peripheral Equipment

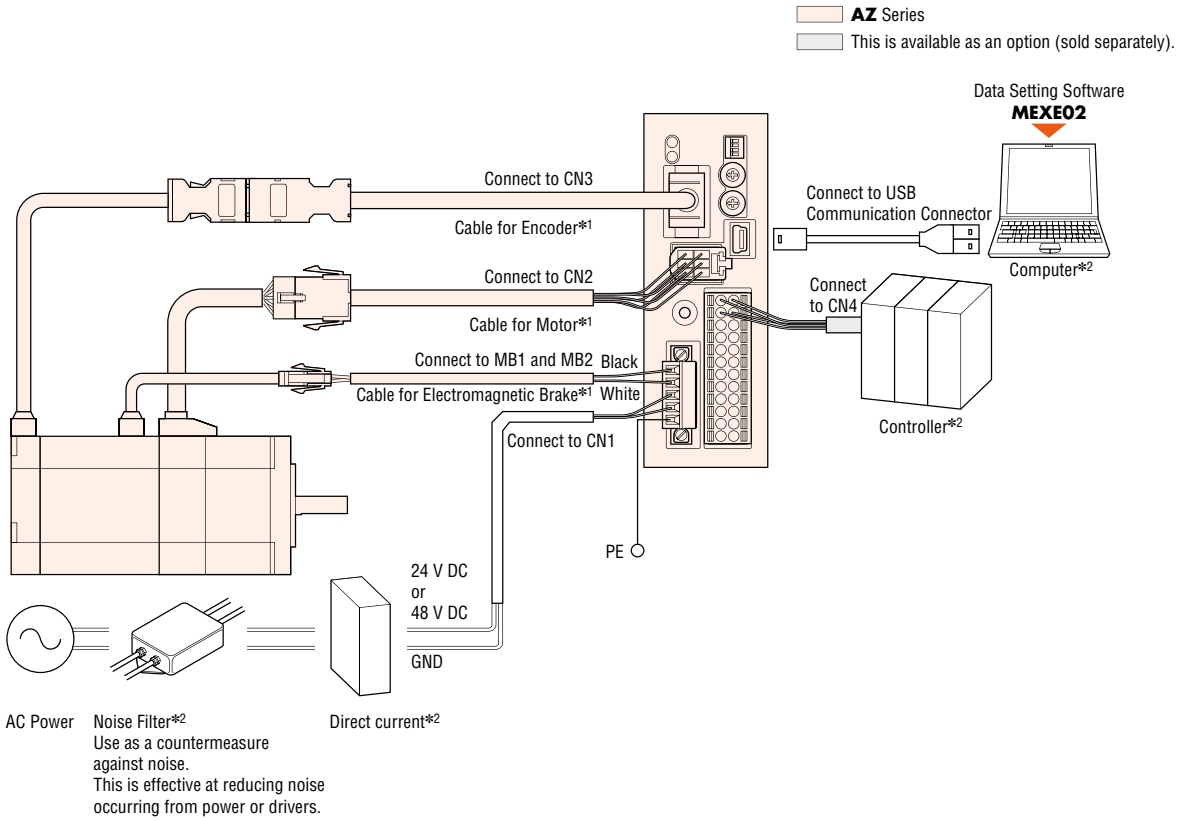

\*1 Please keep the extension between the motor and driver up to 20m  
 \*2 Prepared by the customer.

◇ USB Cable Connection

The computer on which the data setting software **MEXE02** is installed and driver are connected with a USB cable. Use the following specifications for the USB cable.

|               |                       |
|---------------|-----------------------|
| Specification | USB2.0 (full speed)   |
| Cable         | Length: 3 m (or less) |
|               | Format: A-mini-B      |

|                             |
|-----------------------------|
| Features                    |
| System Configuration        |
| Product Line                |
| Specifications and Features |
| Dimensions                  |
| Connection and Operation    |
| System Configuration        |
| Product Line                |
| Specifications and Features |
| Dimensions                  |
| Connection and Operation    |
| Multiaxis Driver            |
| Accessories                 |

◇ Connecting to a Host Controller

● Connecting to a Current Sink Output Circuit

When the pulse input is a line driver

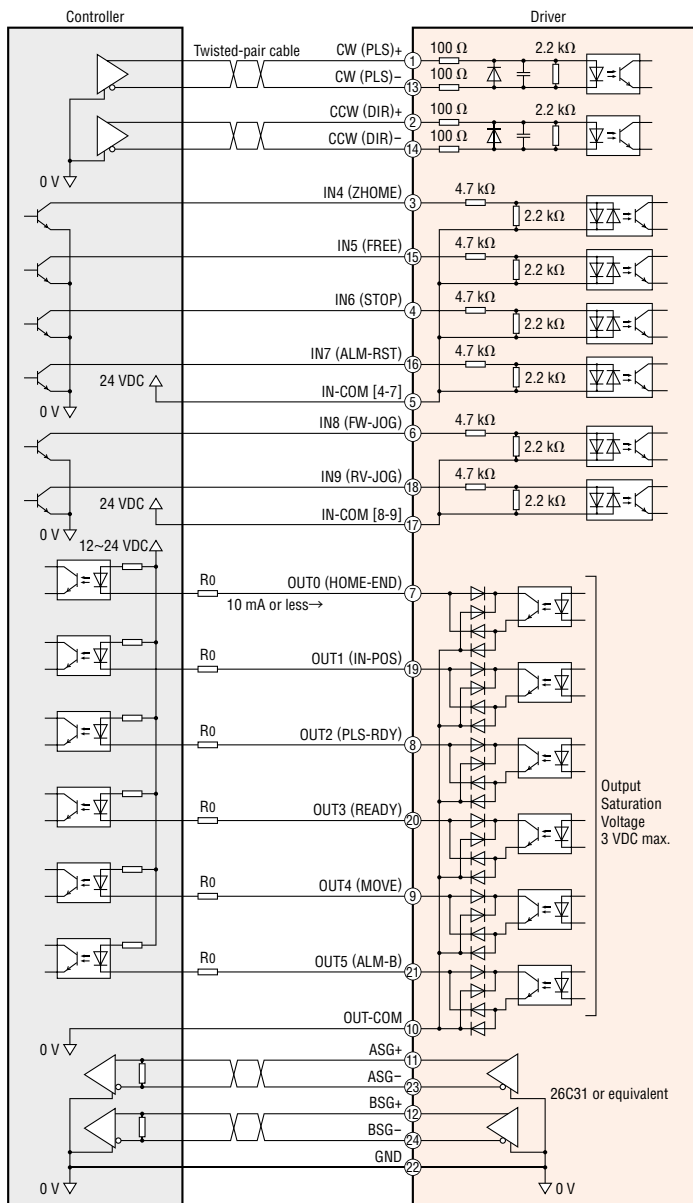

Notes

- For the input signal, use 24 VDC.
- For the output signal, use 12-24 VDC 10 mA or less. Where the current value exceeds 10 mA , connect an external resistor R<sub>0</sub> to reduce the current to 10 mA or less.
- Make sure the signal line is wired at a distance of 200 mm or longer from the power line (power supply line and motor line). Furthermore, do not insert the signal line in the same pipe as the power lines or bundle them together.
- When noise is emitted from the motor cable or power cable due to wiring or allocation and it cause a problem, use shields or ferrite cores.

When the pulse input is an open collector

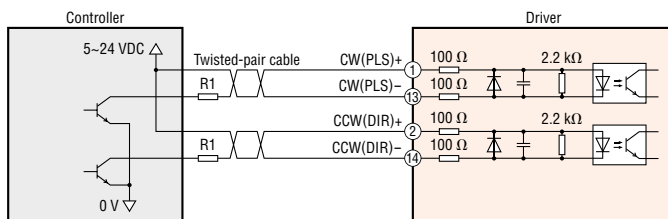

Notes

- For CW (PLS) input , CCW (DIR) input, use 5-24 VDC. Where the voltage exceeds 5 VDC, connect an external resistor R<sub>1</sub> to adjust the input current to be 7-20mA.

◇ Connecting to a Host Controller

● Connecting to a Current Source Output Circuit

When the pulse input is a line driver

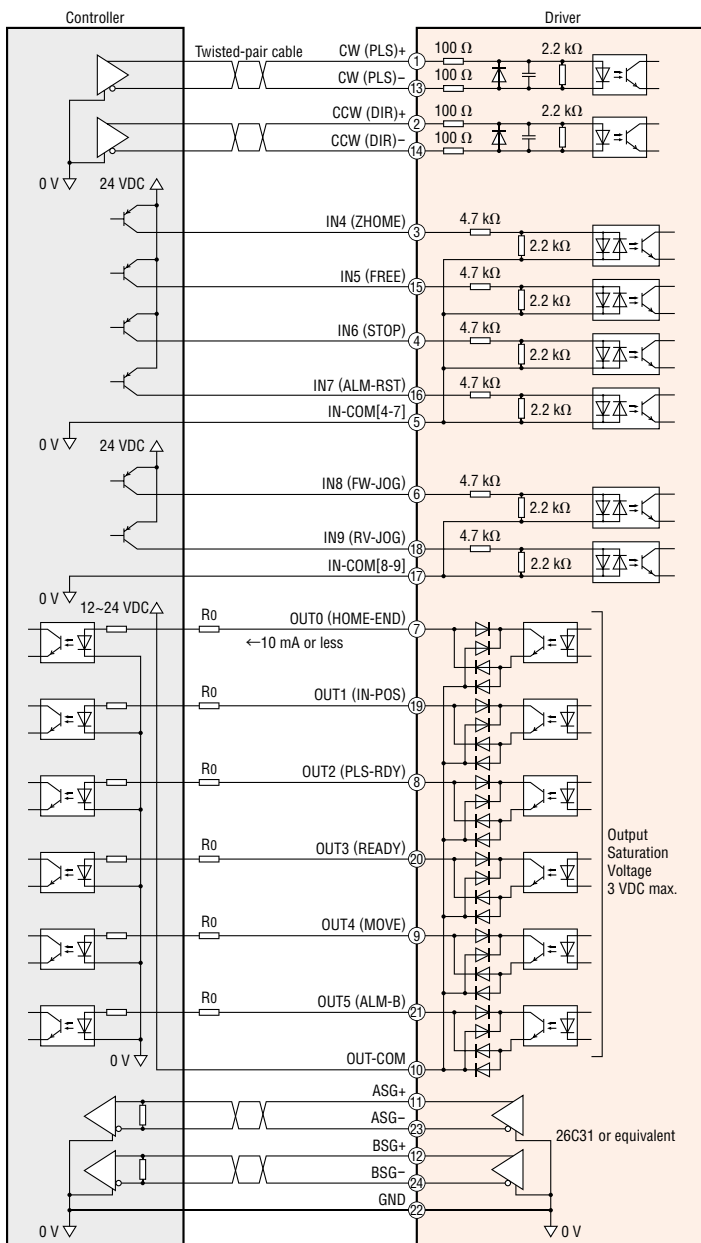

When the pulse input is an open collector

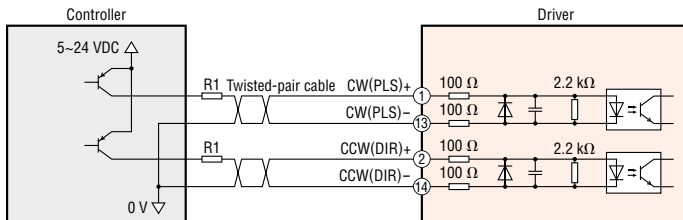

Notes

- For the input signal, use 24 VDC.
- For the output signal, use 12-24 VDC 10 mA or less. Where the current value exceeds 10 mA, connect to an external resistor  $R_0$  to reduce the current to 10 mA or less.
- Make sure the signal line is wired at a distance of 200 mm or longer from the power line (power supply line and motor line). Furthermore, do not insert the signal line in the same pipe as the power lines or bundle them together.
- When noise is emitted from the motor cable or power cable due to wiring or allocation and it cause a problem, use shields or ferrite cores.

Notes

- For CW (PLS) input and CCW (DIR) input, use 5-24 VDC. Where the voltage exceeds 5 VDC, connect an external resistor  $R_1$  to adjust the input current to be 7-20mA.

|                             |
|-----------------------------|
| Features                    |
| System Configuration        |
| Product Line                |
| Specifications and Features |
| AC Input                    |
| Dimensions                  |
| Connection and Operation    |
| System Configuration        |
| Product Line                |
| Specifications and Features |
| DC Input                    |
| Dimensions                  |
| Connection and Operation    |
| Multiaxis Driver            |
| Accessories                 |

# AZ Multi-Axis-Driver Series

DC Power supply

Supports EtherCAT Drive Profiles



The multi-axis driver corresponds to the EtherCAT communication drive profile CiA402. All of our **AZ** motors with DC power input and motorized actuators which are equipped with them can be connected. 2-axis, 3-axis, or 4-axis can be connected to the driver.



## The Multi-axis driver achieves a space-saving and cost reduction (up to 4 axes)

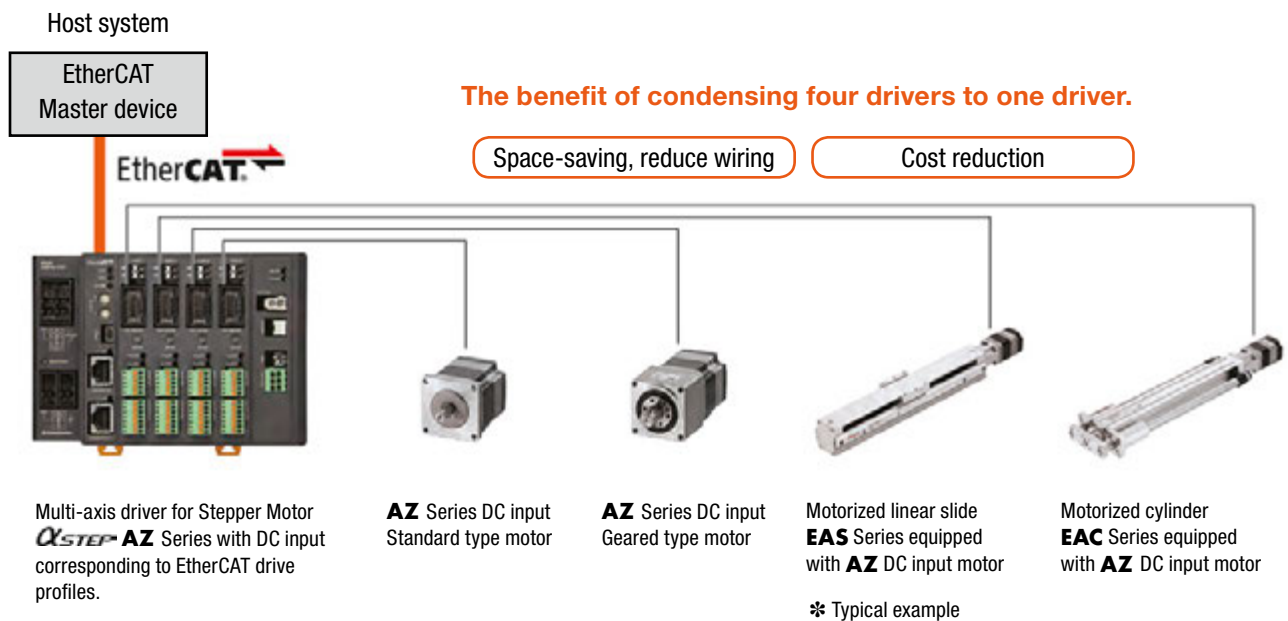

● The motors and actuators shown above are an example.

## Types

| Product Name     | Number of axes |
|------------------|----------------|
| <b>AZD2A-KED</b> | 2              |
| <b>AZD3A-KED</b> | 3              |
| <b>AZD4A-KED</b> | 4              |

## Applicable Series

| Motor   | Actuator  |
|---|---|
| Stepper motor <b>QSTEP AZ</b> Series DC power input | Electric slides <b>EAS</b> Series equipped with <b>QSTEP AZ</b> DC input motor<br>Electric slides <b>EZS</b> Series equipped with <b>QSTEP AZ</b> DC input motor<br>Electric cylinder <b>EAC</b> Series equipped with <b>QSTEP AZ</b> DC input motor<br>Compact Linear actuator <b>DRS2</b> Series equipped with <b>QSTEP AZ</b> DC input motor |

● Refer to each series' catalogue for applicable combinations with motors and actuators.

## System configuration

### Standard **AZ** DC Motor with electromagnetic brake

\* Prepared by the customer

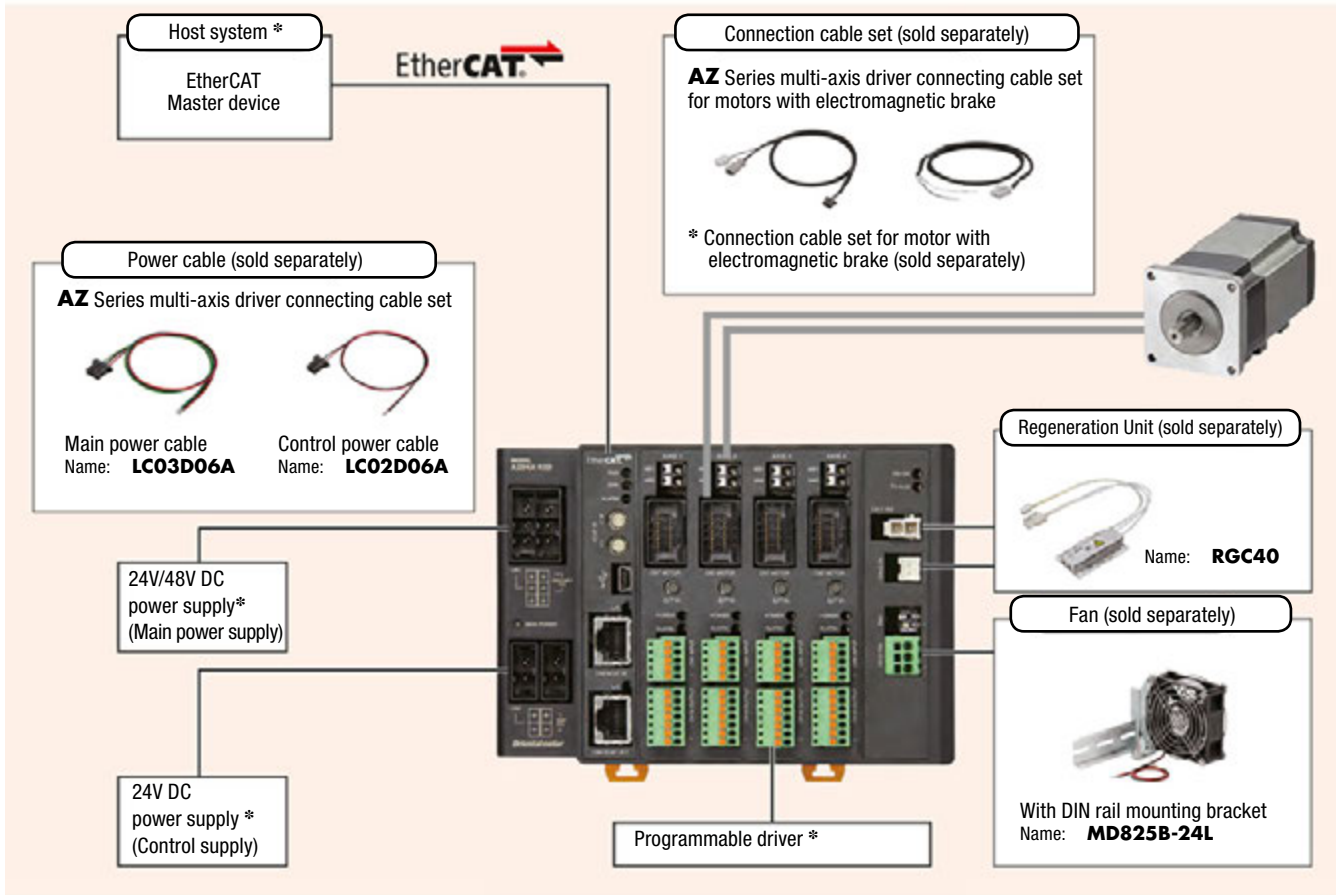

### System Configuration Example

| AZ Series      |                  |                       | Accessory        |                     |                   |
|----------------|------------------|-----------------------|------------------|---------------------|-------------------|
| Motor          | Driver           | Connection Cable Sets | Sold Separately  |                     |                   |
| <b>AZM66MK</b> | <b>AZD4A-KED</b> | <b>CC030VZFBA</b>     | Main Power Cable | Control Power Cable | Regeneration Unit |
| €447.00        | €1,173.00        | €85.00                | <b>LC03D06A</b>  | <b>LC02D06A</b>     | <b>RGC40</b>      |
|                |                  |                       | €14.00           | €12.00              | €43.00            |

The system configuration shown above is an example. Other combinations are also available.

#### Note

The motor cable and electromagnetic brake cable from the motor cannot be connected directly to the driver. When connecting to a driver, use a connection cable.

Features  
System Configuration  
Product Line  
Specifications and Features  
AC Input  
Dimensions  
Connection and Operation  
System Configuration  
Product Line  
Specifications and Features  
DC Input  
Dimensions  
Connection and Operation  
Multiaxis Driver  
Accessories

## Product Number

### Motor

#### Standard Type

**AZD 4A - K ED**

① ② ③ ④

|   |                       |  |
|---|-----------------------|--|
| ① | Driver Type           | <b>AZD</b> : AZ Series Driver                                  |
| ② | Number of Axes        | <b>2A</b> : 2 Axes<br><b>3A</b> : 3 Axes<br><b>4A</b> : 4 Axes |
| ③ | Power Supply Input    | <b>K</b> : DC Power Supply Input                               |
| ④ | Type of communication | <b>ED</b> : EtherCAT Drive profile                             |

### Cables for multi-axis driver

#### Connection Cable Sets/Flexible Connection Cable Sets

#### For Standard Motor

**CC 050 V Z □ F A**

① ② ③ ④ ⑤ ⑥ ⑧

#### For Electro Magnetic type motor

**CC 050 V Z F B A**

① ② ③ ④ ⑥ ⑦ ⑧

|   |                       |  |
|---|-----------------------|--|
| ① |                       | <b>CC</b> : Cable  |
| ② | Length                | <b>005</b> : 0.5 m <b>010</b> : 1 m <b>015</b> : 1.5 m <b>020</b> : 2 m<br><b>025</b> : 2.5 m <b>030</b> : 3 m <b>040</b> : 4 m <b>050</b> : 5 m<br><b>070</b> : 7 m <b>100</b> : 10 m <b>150</b> : 15 m <b>200</b> : 20 m |
| ③ | Reference Number      |  |
| ④ | Applicable Models     | <b>Z</b> : AZ Series   |
| ⑤ | Reference Number      | Blank: Frame Size 42 mm ( <b>HPG</b> Geared Type is 40 mm),<br>60 mm<br><b>2</b> : Frame Size 20 mm, 28 mm   |
| ⑥ | Cable Type            | <b>F</b> : Connection Cable Sets<br><b>R</b> : Flexible Connection Cable Sets  |
| ⑦ | Electromagnetic Brake | <b>B</b> : With Electromagnetic Brake  |
| ⑧ | Driver Type           | <b>A</b> : For Multi-Axis Driver   |

## Product Line

### Multi-Axis Driver

#### EtherCAT Drive Profile Compliant



| Product Name     | Number of Axes | List Price |
|------------------|----------------|------------|
| <b>AZD2A-KED</b> | <b>2</b> Axes  | €733.00    |
| <b>AZD3A-KED</b> | <b>3</b> Axes  | €971.00    |
| <b>AZD4A-KED</b> | <b>4</b> Axes  | €1,173.00  |

### AZ Series Multi-Axis Driver Connection Cable Sets/ Flexible Connection Cable Sets

#### Motor Connection Cables



| Length<br>L (m) | Frame Size 20 mm, 28 mm |            |                           |            | Frame Size 42 mm, 60 mm |            |                           |            |
|-----------------|-------------------------|------------|---------------------------|------------|-------------------------|------------|---------------------------|------------|
|                 | Connection Cable        | List Price | Flexible Connection Cable | List Price | Connection Cable        | List Price | Flexible Connection Cable | List Price |
| 0.5             | <b>CC005VZ2FA</b>       | € 54,00    | <b>CC005VZ2RA</b>         | € 65,00    | <b>CC005VZFA</b>        | € 54,00    | <b>CC005VZRA</b>          | € 65,00    |
| 1               | <b>CC010VZ2FA</b>       | € 54,00    | <b>CC010VZ2RA</b>         | € 65,00    | <b>CC010VZFA</b>        | € 54,00    | <b>CC010VZRA</b>          | € 65,00    |
| 1.5             | <b>CC015VZ2FA</b>       | € 58,00    | <b>CC015VZ2RA</b>         | € 70,00    | <b>CC015VZFA</b>        | € 58,00    | <b>CC015VZRA</b>          | € 70,00    |
| 2               | <b>CC020VZ2FA</b>       | € 61,00    | <b>CC020VZ2RA</b>         | € 76,00    | <b>CC020VZFA</b>        | € 61,00    | <b>CC020VZRA</b>          | € 76,00    |
| 2.5             | <b>CC025VZ2FA</b>       | € 66,00    | <b>CC025VZ2RA</b>         | € 81,00    | <b>CC025VZFA</b>        | € 66,00    | <b>CC025VZRA</b>          | € 81,00    |
| 3               | <b>CC030VZ2FA</b>       | € 69,00    | <b>CC030VZ2RA</b>         | € 85,00    | <b>CC030VZFA</b>        | € 69,00    | <b>CC030VZRA</b>          | € 85,00    |
| 4               | <b>CC040VZ2FA</b>       | € 77,00    | <b>CC040VZ2RA</b>         | € 97,00    | <b>CC040VZFA</b>        | € 77,00    | <b>CC040VZRA</b>          | € 97,00    |
| 5               | <b>CC050VZ2FA</b>       | € 84,00    | <b>CC050VZ2RA</b>         | € 108,00   | <b>CC050VZFA</b>        | € 84,00    | <b>CC050VZRA</b>          | € 108,00   |
| 7               | <b>CC070VZ2FA</b>       | € 104,00   | <b>CC070VZ2RA</b>         | € 138,00   | <b>CC070VZFA</b>        | € 104,00   | <b>CC070VZRA</b>          | € 138,00   |
| 10              | <b>CC100VZ2FA</b>       | € 135,00   | <b>CC100VZ2RA</b>         | € 181,00   | <b>CC100VZFA</b>        | € 135,00   | <b>CC100VZRA</b>          | € 181,00   |
| 15              | <b>CC150VZ2FA</b>       | € 187,00   | <b>CC150VZ2RA</b>         | € 254,00   | <b>CC150VZFA</b>        | € 187,00   | <b>CC150VZRA</b>          | € 254,00   |
| 20              | <b>CC200VZ2FA</b>       | € 237,00   | <b>CC200VZ2RA</b>         | € 326,00   | <b>CC200VZFA</b>        | € 237,00   | <b>CC200VZRA</b>          | € 326,00   |



## ◇ Connection Cables for Motors with Electromagnetic Brake

| Length<br>L (m) | Frame Size 42 mm, 60 mm |            |                           |            |
|-----------------|-------------------------|------------|---------------------------|------------|
|                 | Connection Cable        | List Price | Flexible Connection Cable | List Price |
| 0.5             | <b>CC005VZFBA</b>       | € 66,00    | <b>CC005VZRBA</b>         | € 87,00    |
| 1               | <b>CC010VZFBA</b>       | € 66,00    | <b>CC010VZRBA</b>         | € 87,00    |
| 1.5             | <b>CC015VZFBA</b>       | € 71,00    | <b>CC015VZRBA</b>         | € 95,00    |
| 2               | <b>CC020VZFBA</b>       | € 75,00    | <b>CC020VZRBA</b>         | € 103,00   |
| 2.5             | <b>CC025VZFBA</b>       | € 81,00    | <b>CC025VZRBA</b>         | € 109,00   |
| 3               | <b>CC030VZFBA</b>       | € 85,00    | <b>CC030VZRBA</b>         | € 115,00   |
| 4               | <b>CC040VZFBA</b>       | € 94,00    | <b>CC040VZRBA</b>         | € 131,00   |
| 5               | <b>CC050VZFBA</b>       | € 103,00   | <b>CC050VZRBA</b>         | € 146,00   |
| 7               | <b>CC070VZFBA</b>       | € 127,00   | <b>CC070VZRBA</b>         | € 184,00   |
| 10              | <b>CC100VZFBA</b>       | € 163,00   | <b>CC100VZRBA</b>         | € 237,00   |
| 15              | <b>CC150VZFBA</b>       | € 225,00   | <b>CC150VZRBA</b>         | € 331,00   |
| 20              | <b>CC200VZFBA</b>       | € 285,00   | <b>CC200VZRBA</b>         | € 422,00   |



### Note

● For the Multi-Axis Driver only connection cables are provided. AZ Series extension cables cannot be used.

## ■ Included

### ● Multi-Axis Driver

| Type, Number of Axes | Included | Connector for CN1 | Connector for CN2 | Contact for CN1, CN2 | Connector Cap for CN4, CN5 | Connector for CN9 | Connector for CN10 | Operating Manual |
|----------------------|----------|-------------------|-------------------|----------------------|----------------------------|-------------------|--------------------|------------------|
| EtherCAT Compliant   | 2 Axes   | 2 Pieces          | 2 Pieces          | 10 Pieces            | 2 Pieces                   | 2 Pieces          | 2 Pieces           | 1 Copy           |
|                      | 3 Axes   | 2 Pieces          | 2 Pieces          | 10 Pieces            | 2 Pieces                   | 3 Pieces          | 3 Pieces           | 1 Copy           |
|                      | 4 Axes   | 2 Pieces          | 2 Pieces          | 10 Pieces            | 2 Pieces                   | 4 Pieces          | 4 Pieces           | 1 Copy           |

## ■ Specifications

### ● Power Supply Input

Main Power Supply: 24/48 VDC ±10% 7.0A (Max. 7.0 A, please use average 4.0 A or less)

Control Power Supply: 24 VDC ±10% 1.5A (For the type with an electromagnetic brake a 24 VDC±5% specification applies)

(For the type with an electromagnetic brake with 20 m connection cable a 24 VDC ±4% specification applies)

### ◇ EtherCAT Specifications

| Item                   | Content   |
|------------------------|---|
| Baud Rate              | 100 Mbps  |
| Communication Period   | 0.5ms/1ms/2ms/3ms/4ms/5ms/6ms/7ms/8ms                     |
| Node Address           | 0~255(00h~FFh, initial value:00h)                         |
| Communication Protocol | EtherCAT dedicated protocol (CoE)<br>CiA402 drive profile |

### ● General Specification

| Item                                | Content   |
|-------------------------------------|---|
| Degree of Protection                | <b>IP10</b>   |
| Operating Environment               | Ambient temperature: 0~+50°C (Non-freezing)<br>Ambient Humidity: 85% or less (Non-condensing)<br>Altitude: Max. 1000 m above sea level<br>Atmosphere: No corrosive gases or dust. The product should not be exposed to water, oil or other liquids.   |
| Storage, Transportation Environment | Ambient temperature: -25~+70°C (Non-freezing)<br>Ambient Humidity: 85% or less (Non-condensing)<br>Altitude: Max. 3000 m above sea level<br>Atmosphere: No corrosive gases or dust. The product should not be exposed to water, oil or other liquids. |
| Insulation Resistance               | 100MΩ or more when a 500 VDC megger is applied between the following parts:<br>- FG Terminal - Power Supply Terminal  |
| Dielectric Voltage                  | Sufficient to withstand for 1 minute:<br>- EtherCAT Compliant: FG Terminal - Power Supply Terminal 1 kVAC, 50 Hz or 60 Hz, leakage current 10 mA or less  |

### Note

● Do not measure insulation resistance or perform a dielectric strength test while the motor and driver are connected. Also, do not perform these tests on the motor absolute sensor part.

Features

System Configuration

Product Line

AC Input

Specifications and Features

Dimensions

Connection and Operation

System Configuration

Product Line

Specifications and Features

DC Input

Dimensions and Operation

MultiAxis Driver

Accessories

## Dimensions (Unit = mm)

### Multi-Axis Driver (EtherCAT Compliant)

| Number of Axes | Type | Product Name     | Mass KG |
|----------------|------|------------------|---------|
| 2 Axes         |      | <b>AZD2A-KED</b> | 0.39    |
| 3 Axes         |      | <b>AZD3A-KED</b> | 0.42    |
| 4 Axes         |      | <b>AZD4A-KED</b> | 0.45    |

● The dimensions for 2 axes, 3 axes and 4 axes are the same.

● Included

Connector for Main Power: F32FSS-03V-KX (JST)

Connector for Control Power: F32FSS-02V-KX (JST)

Connector for Main Power/Control Power: LF3F-41GF-P2.0 (JST)

Connector for Input Signals: FK-MC 0,5/ 5-ST-2,5 (PHOENIX CONTACT)

Connector for Output Signals: FK-MC 0,5/ 7-ST-2,5 (PHOENIX CONTACT)

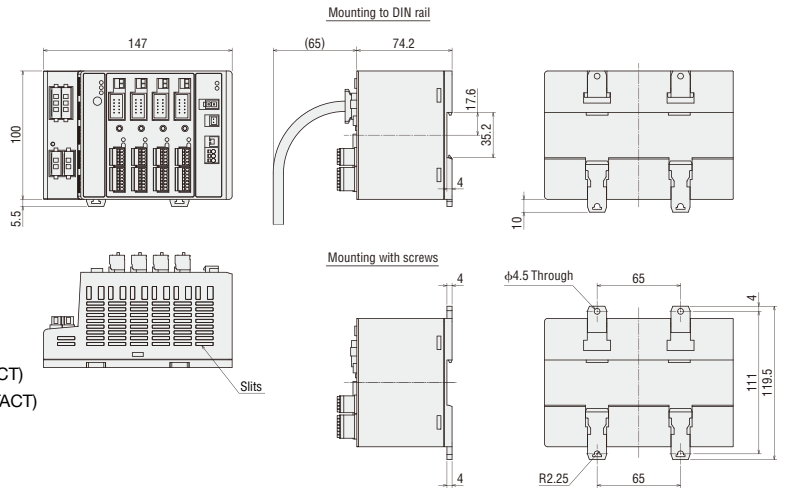

### Connection Cable Sets/Flexible Connection Cable Sets

◇ Cable for Motor

#### ● Frame Size 20 mm, 28 mm

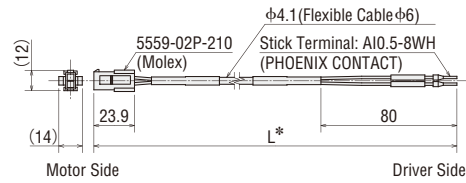
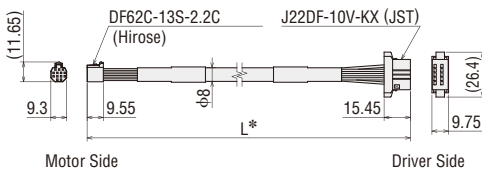

\*The length L (m) is specified where L is located in the dimensions in "Product Line" on page 112-113

#### ● Frame Size 42 mm, 60 mm

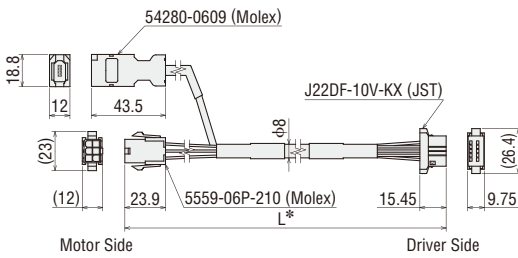

◇ Cable for Electromagnetic Brake

#### ● Frame Size 42 mm, 60 mm

## Multi-Axis Driver Accessories

### Power Supply Cables (Sold Separately)

Lead wire cables with connectors for **AZ** Series Multi-Axis Drivers. Main power supply and control power supply can be connected easily.

#### Product Line

| Product Name    | Type                 | List Price |
|-----------------|----------------------|------------|
| <b>LC03D06A</b> | Main Power Supply    | €14.00     |
| <b>LC02D06A</b> | Control Power Supply | €12.00     |



#### Dimensions (Unit = mm)

Cable for Main Power Supply

##### LC03D06A

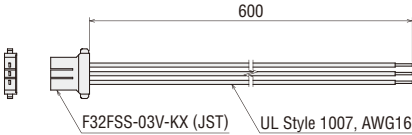

Cable for Control Power Supply

##### LC02D06A

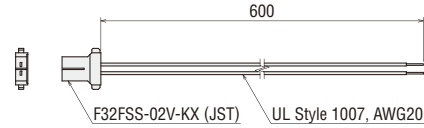

### Regeneration Unit

During vertical drive (gravitational operation) or sudden start/stop in high inertia, an external force causes the motor to rotate and function as a power generator. When the regenerative power exceeds the driver's regenerative power absorption capacity, it may cause damage to the motor. In such a case, the regeneration unit is connected to the driver to convert regenerative energy into thermal energy for dissipation.

As the Multi-Axis Driver uses 24 VDC, an alarm output can happen easily, therefore the use of the regeneration unit is recommended.



#### Product Line

| Product Name | List Price |
|--------------|------------|
| <b>RGC40</b> | €43.00     |

#### Specification

| Item                             | Content   |
|----------------------------------|---|
| Permissible Power Consumption    | Continuous regenerative power: 40W*<br>Instantaneous regenerative power: 400W |
| Resistance Value                 | 15Ω   |
| Thermostat Operating Temperature | Operation: 95±5°C<br>Reset: 65±15°C<br>(Normally closed)                      |
| Thermostat Electrical Rating     | 250 VAC 0.5 A<br>(Min. current 1.5 VDC 1 mA)                                  |

\*Install the regeneration unit in a place that has the same heat radiation capability as the heat sink (material: aluminum 180x150 mm, 2 mm thick).

#### Dimensions (Unit = mm)

Mass: 0.03kg

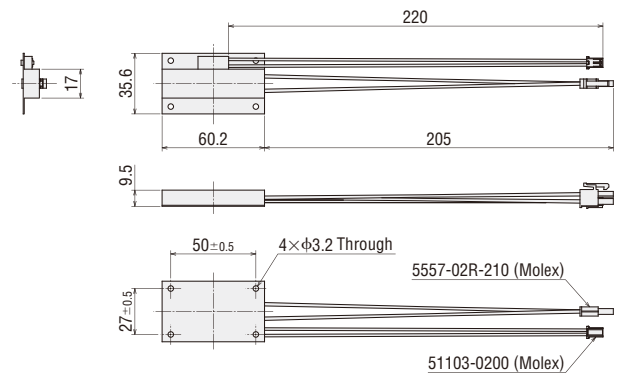

Features

System Configuration

Product Line

AC Input

Specifications and Features

Dimensions

Connection and Operation

System Configuration

Product Line

Specifications and Features

DC Input

Dimensions

Connection and Operation

Multiaxis Driver

Accessories

# Accessories (Sold separately)

## Connection Cable Sets, Flexible Connection Cable Sets Extension Cable Sets, Flexible Extension Cable Sets

In the **AZ** series, there are products with cable for connecting between motor and driver (1 m, 2 m, 3 m) as well as those to which such cable is not attached.

When using the motor and driver more than 3 m apart, choose the connection cable set or extension cable set.

The extension cable maximum extension length is 20 m (including attached cable).

For the standard motor, the cable for motor cable and the cable for encoder make up the set. Whereas for the magnetic brake-attached motor, the cable for motor, the cable for encoder and the cable for magnetic brake make up the set.

If the cable becomes bent, use the flexible connection cable set or flexible extension cable set.

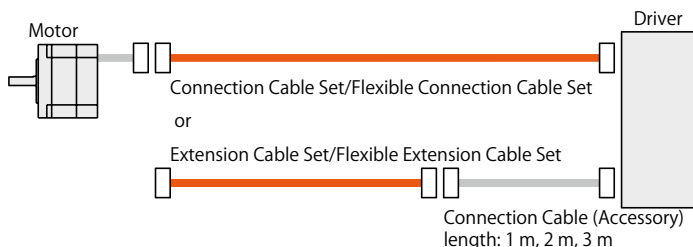

### Notes

● Cables for motor and magnetic brake from the motor cannot be connected directly to the driver. When connecting to the driver, use the optional (sold separately) connection cable or the connection cable attached to the product (only for types with a connection cable attached).

## AC Input

### Extension Cable Sets, Flexible Extension Cable Set

#### Product Line

##### ● Extension Cable Sets

###### ◇ For Standard Motor



Cable for Motor

Cable for Encoder

| Product Name     | Length L (m) | List Price |
|------------------|--------------|------------|
| <b>CC010VZFT</b> | 1            | €55.00     |
| <b>CC020VZFT</b> | 2            | €62.00     |
| <b>CC030VZFT</b> | 3            | €70.00     |
| <b>CC050VZFT</b> | 5            | €84.00     |
| <b>CC070VZFT</b> | 7            | €104.00    |
| <b>CC100VZFT</b> | 10           | €135.00    |
| <b>CC150VZFT</b> | 15           | €187.00    |

###### ◇ For Electromagnetic Brake Motor



Cable for Motor

Cable for Encoder

Cable for Electromagnetic Brake

| Product Name      | Length L (m) | List Price |
|-------------------|--------------|------------|
| <b>CC010VZFBT</b> | 1            | €66.00     |
| <b>CC020VZFBT</b> | 2            | €75.00     |
| <b>CC030VZFBT</b> | 3            | €85.00     |
| <b>CC050VZFBT</b> | 5            | €103.00    |
| <b>CC070VZFBT</b> | 7            | €127.00    |
| <b>CC100VZFBT</b> | 10           | €163.00    |
| <b>CC150VZFBT</b> | 15           | €225.00    |

##### ● Flexible Extension Cable Sets

###### ◇ For Standard Motor



Cable for Motor

Cable for Encoder

| Product Name     | Length L (m) | List Price |
|------------------|--------------|------------|
| <b>CC010VZRT</b> | 1            | €65.00     |
| <b>CC020VZRT</b> | 2            | €76.00     |
| <b>CC030VZRT</b> | 3            | €85.00     |
| <b>CC050VZRT</b> | 5            | €108.00    |
| <b>CC070VZRT</b> | 7            | €137.00    |
| <b>CC100VZRT</b> | 10           | €181.00    |
| <b>CC150VZRT</b> | 15           | €262.00    |

###### ◇ For Electromagnetic Brake Motor



Cable for Motor

Cable for Encoder

Cable for Electromagnetic Brake

| Product Name      | Length L (m) | List Price |
|-------------------|--------------|------------|
| <b>CC010VZRBT</b> | 1            | €87.00     |
| <b>CC020VZRBT</b> | 2            | €103.00    |
| <b>CC030VZRBT</b> | 3            | €115.00    |
| <b>CC050VZRBT</b> | 5            | €146.00    |
| <b>CC070VZRBT</b> | 7            | €184.00    |
| <b>CC100VZRBT</b> | 10           | €237.00    |
| <b>CC150VZRBT</b> | 15           | €331.00    |

## ■ Dimensions (Unit = mm)

### ● Connection Cable

#### ◇ Motor Cable

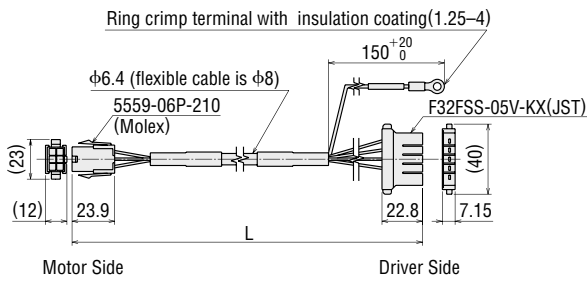

#### ◇ Encoder Cable

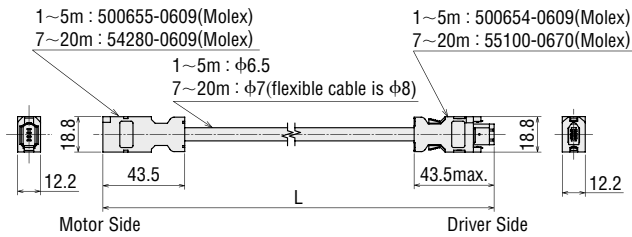

#### ◇ Electromagnetic Brake Cable

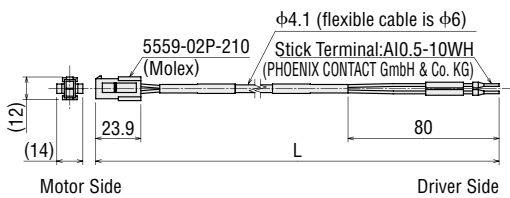

### ● Extension Cable

#### ◇ Motor Cable

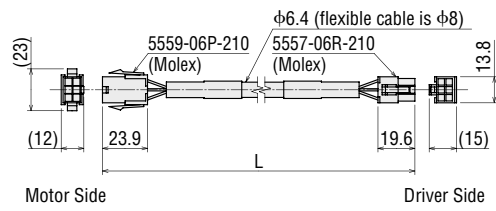

#### ◇ Encoder Cable

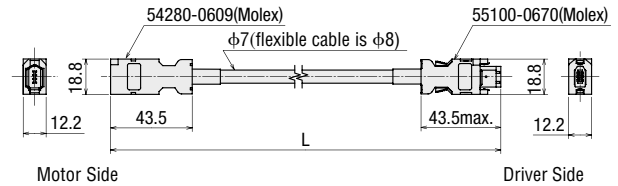

#### ◇ Electromagnetic Brake Cable

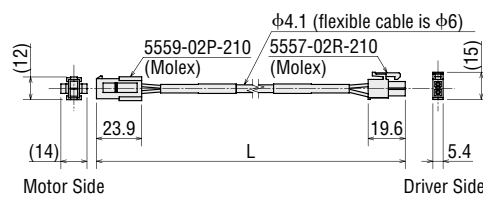

## DC Input

## Extension Cable Sets, Flexible Extension Cable Sets

### ■ Product Line

[For **AZ14**, **AZ15**, **AZ24**, **AZ26**]

#### ● Extension Cable

##### ◇ For Standard Motor



| Product Name      | Length L (m) | List Price |
|-------------------|--------------|------------|
| <b>CC010VZ2FT</b> | 1            | €55.00     |
| <b>CC020VZ2FT</b> | 2            | €62.00     |
| <b>CC030VZ2FT</b> | 3            | €70.00     |
| <b>CC050VZ2FT</b> | 5            | €84.00     |
| <b>CC070VZ2FT</b> | 7            | €104.00    |
| <b>CC100VZ2FT</b> | 10           | €135.00    |
| <b>CC150VZ2FT</b> | 15           | €187.00    |

#### ● Flexible Extension Cable

##### ◇ For Standard Motor



| Product Name      | Length L (m) | List Price |
|-------------------|--------------|------------|
| <b>CC010VZ2RT</b> | 1            | €65.00     |
| <b>CC020VZ2RT</b> | 2            | €76.00     |
| <b>CC030VZ2RT</b> | 3            | €85.00     |
| <b>CC050VZ2RT</b> | 5            | €108.00    |
| <b>CC070VZ2RT</b> | 7            | €138.00    |
| <b>CC100VZ2RT</b> | 10           | €181.00    |
| <b>CC150VZ2RT</b> | 15           | €254.00    |

[For **AZ46, AZ48, AZ66, AZ69**]

● Extension Cable Sets

◇ For Standard Motor



Cable for Motor      Cable for Encoder

| Product Name     | Length L (m) | List Price |
|------------------|--------------|------------|
| <b>CC010VZFT</b> | 1            | €55.00     |
| <b>CC020VZFT</b> | 2            | €62.00     |
| <b>CC030VZFT</b> | 3            | €70.00     |
| <b>CC050VZFT</b> | 5            | €84.00     |
| <b>CC070VZFT</b> | 7            | €104.00    |
| <b>CC100VZFT</b> | 10           | €135.00    |
| <b>CC150VZFT</b> | 15           | €187.00    |

● Flexible Extension Cable Sets

◇ For Standard Motor



Cable for Motor      Cable for Encoder

| Product Name     | Length L (m) | List Price |
|------------------|--------------|------------|
| <b>CC010VZRT</b> | 1            | €65.00     |
| <b>CC020VZRT</b> | 2            | €76.00     |
| <b>CC030VZRT</b> | 3            | €85.00     |
| <b>CC050VZRT</b> | 5            | €108.00    |
| <b>CC070VZRT</b> | 7            | €137.00    |
| <b>CC100VZRT</b> | 10           | €181.00    |
| <b>CC150VZRT</b> | 15           | €262.00    |

◇ For Electromagnetic Brake Motor



Cable for Motor      Cable for Encoder      Cable for Electromagnetic Brake

| Product Name      | Length L (m) | List Price |
|-------------------|--------------|------------|
| <b>CC010VZFBT</b> | 1            | €66.00     |
| <b>CC020VZFBT</b> | 2            | €75.00     |
| <b>CC030VZFBT</b> | 3            | €85.00     |
| <b>CC050VZFBT</b> | 5            | €103.00    |
| <b>CC070VZFBT</b> | 7            | €127.00    |
| <b>CC100VZFBT</b> | 10           | €163.00    |
| <b>CC150VZFBT</b> | 15           | €225.00    |

◇ For Electromagnetic Brake Motor



Cable for Motor      Cable for Encoder      Cable for Electromagnetic Brake

| Product Name      | Length L (m) | List Price |
|-------------------|--------------|------------|
| <b>CC010VZRBt</b> | 1            | €87.00     |
| <b>CC020VZRBt</b> | 2            | €103.00    |
| <b>CC030VZRBt</b> | 3            | €115.00    |
| <b>CC050VZRBt</b> | 5            | €146.00    |
| <b>CC070VZRBt</b> | 7            | €184.00    |
| <b>CC100VZRBt</b> | 10           | €237.00    |
| <b>CC150VZRBt</b> | 15           | €331.00    |

■ Dimensions (Unit = mm)

[For **AZ14, AZ15, AZ24, AZ26**]

● Connection Cable

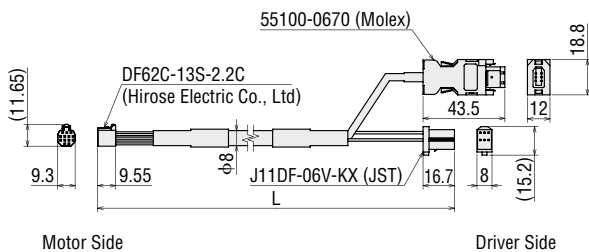

● Extension Cable

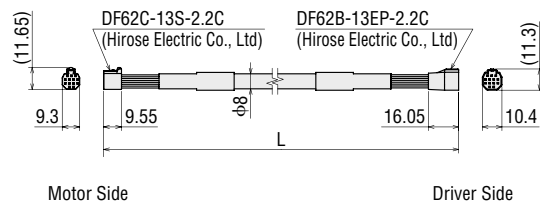

[For **AZ46, AZ66, AZ69**]

● Connection Cable

◇ Cable for Motor

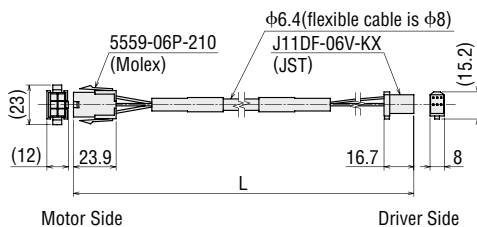

◇ Cable for Electromagnetic Brake

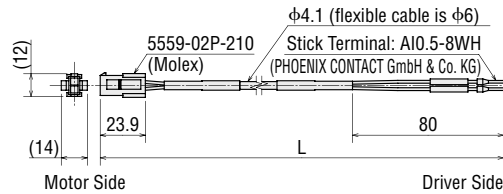

◇ Cable for Encoder

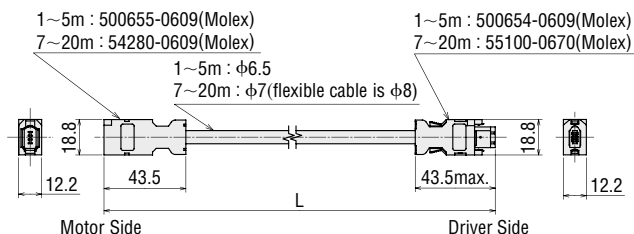

● Extension Cable

◇ Cable for Motor

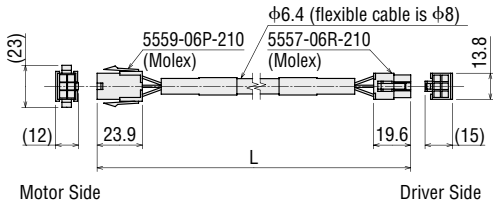

◇ Cable for Electromagnetic Brake

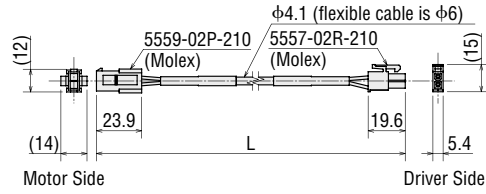

◇ Cable for Encoder

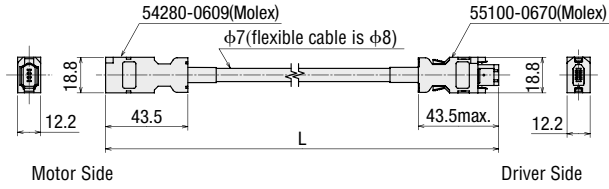

■ Notes on Use of a Flexible Cable

① Do not allow the cable to bend at the cable connector.

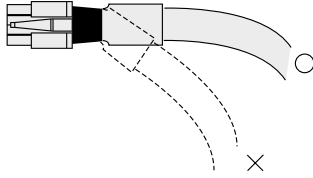

② For the bending radius, use at six times or more of the cable diameter.

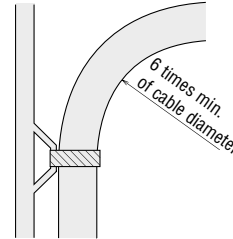

③ The cable wired from the motor or the cable comes as a set of the motor should not be bent. Use a flexible motor cable, if the cable will be bend.

● Flexible Connection Cable

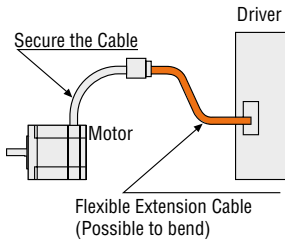

● Flexible Extension Cable

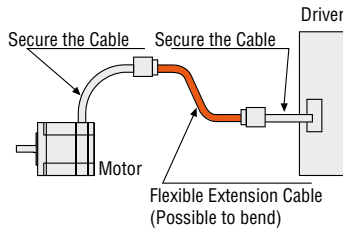

|                             |
|-----------------------------|
| Features                    |
| System Configuration        |
| Product Line                |
| Specifications and Features |
| AC Input                    |
| Dimensions                  |
| Connection and Operation    |
| System Configuration        |
| Product Line                |
| Specifications and Features |
| DC Input                    |
| Dimensions                  |
| Connection and Operation    |
| Multiaxis Driver            |

# Data Setting Software MEXE02

From the computer, it is not only possible to set and edit driving data and the various parameters, but also to monitor the waveforms of teaching, I/O and driving speed.

The data setting software is available for download from our website.

Furthermore, the data setting software is distributed on a CD-ROM.

For details, ask from our website or inquire at your nearest branch or sales office.

## Operating Environment

### Computer

|                      |  |
|----------------------|--|
| Recommended CPU*1    | Intel Core Processor 2 GHz or more<br>(The OS must be supported.)        |
| Display              | high resolution video adapter and monitor, XGA (1024x768) or more.       |
| Recommended Memory*1 | 32 bit (x86) version: 1 GB or more<br>64 bit (x64) version: 2 GB or more |
| Hard Disk*2          | Available disk space of 60 MB or more                                    |
| USB Port             | USB2.0 1 port  |
| Disk Device          | CD-ROM drive (use for installation of software)                          |

\*1 The OS operating conditions need to be satisfied.

\*2 Microsoft .NET Framework 4 Client Profile is required to use MEXE02. If it is not already installed, it will be installed automatically, in which case up to 1.5 GB of additional space is required.

Windows and Windows Vista are registered trademarks of Microsoft Corporation in the United States and other countries. Pentium is a trademark of Intel Corporation.

Please refer to our website for the latest update of operating environment.

#### Notes

The required volume of memory or hard disk may vary depending on the system environment.

### Operating Systems (OS)

Both the 32-bit (x86) and 64 bit (x64) editions are supported.

- Microsoft Windows XP Service Pack 3\*
- Microsoft Windows Vista Service Pack 2
- Microsoft Windows 7 Service Pack 1
- Microsoft Windows 8
- Microsoft Windows 8.1

\*This works with Service Pack 2 when using 64 bit (x64) edition.

## Connection between Computer and Driver

Use the following specifications for the USB cable.

|               |   |
|---------------|---|
| Specification | USB2.0 (full speed)                       |
| Cable         | Length: 3 m (or less)<br>Format: A-mini-B |

## Generic Cable for Input/Output Signals

This is a convenient multi-core cable for connecting the driver and upper level controller.

Choose the necessary cable in accordance with the number of connecting I/O signals.



### Product Line

| Lead wire No. of cores | Cable Length |             |             |             |
|------------------------|--------------|-------------|-------------|-------------|
|                        | 0.5 m        | 1 m         | 1.5 m       | 2 m         |
| 6                      | CC06D005B-1  | CC06D010B-1 | CC06D015B-1 | CC06D020B-1 |
| 10                     | CC10D005B-1  | CC10D010B-1 | CC10D015B-1 | CC10D020B-1 |
| 12                     | CC12D005B-1  | CC12D010B-1 | CC12D015B-1 | CC12D020B-1 |
| 16                     | CC16D005B-1  | CC16D010B-1 | CC16D015B-1 | CC16D020B-1 |

### Dimensions (Unit = mm)

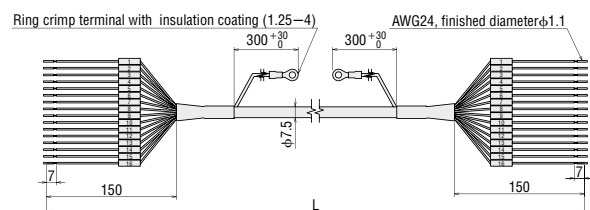

The outline drawing is of 16 cores.

## RS-485 Communication Cable

The cable is to link drivers when the driver is being operated under multi-axis mode, it also connects the network converter and driver.



### Product Line

| Product Name | Applicable Product   | Length L (m) |
|--------------|--|--------------|
| CC001-RS4    | DC Power Supply Input Driver                                 | 0.1          |
| CC002-RS4    | AC Power Supply Input Driver<br>DC Power Supply Input Driver | 0.25         |

### Dimensions (Unit = mm)

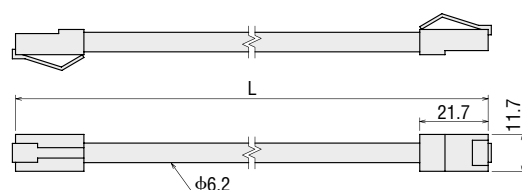



# MCV Couplings

This is a one piece structure coupling with the vibration-proof rubber formed between the aluminium alloy hubs.



## Product Line

Product Name

**MCV15**□

**MCV19**□

**MCV25**□

**MCV30**□

● A number indicating the coupling inner diameter is entered where the box is located within the product name.

## Product Number Code

# MCV 25 10 12

①      ②      ③      ④

|   |   |
|---|---|
| ① | <b>MCV</b> Couplings  |
| ② | Outer Diameter of Coupling  |
| ③ | Inner Diameter d1 (smaller inner diameter)<br>( <b>06A</b> represents $\phi 6.35$ mm) |
| ④ | Inner Diameter d2 (larger inner diameter)<br>( <b>06A</b> represents $\phi 6.35$ mm)  |

● For inner diameter d1, the smaller of the motor shaft diameter or the driven shaft diameter is entered.  
For inner diameter d2, the larger of the motor shaft diameter or the driven shaft diameter is entered.

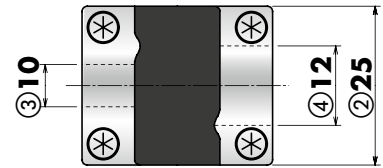

## Coupling Selection Table

- Coupling is selected based on the following content.
  - The motor output torque is within the generic torque for coupling.
  - Motor shaft diameter

| Applicable Product |            |                    | Coupling Type | Motor Shaft Diameter mm |           | Driven Shaft Diameter mm |          |          |          |             |          |           |           |           |           |  |
|--------------------|------------|--------------------|---------------|-------------------------|-----------|--------------------------|----------|----------|----------|-------------|----------|-----------|-----------|-----------|-----------|--|
| Type               | Frame Size | Product Name       |               |                         |           | 03                       | 04       | 05       | 06       | 06A         | 08       | 10        | 12        | 14        | 15        |  |
|                    |            |                    |               |                         |           | $\phi 3$                 | $\phi 4$ | $\phi 5$ | $\phi 6$ | $\phi 6.35$ | $\phi 8$ | $\phi 10$ | $\phi 12$ | $\phi 14$ | $\phi 15$ |  |
| Standard Type      | 20 mm      | <b>AZ14, AZ15</b>  | <b>MCV15</b>  | <b>04</b>               | $\phi 4$  |                          | ●        | ●        | ●        |             |          |           |           |           |           |  |
|                    | 28 mm      | <b>AZ24, AZ26</b>  |               | <b>05</b>               | $\phi 5$  | ●                        | ●        | ●        | ●        |             |          |           |           |           |           |  |
|                    | 42 mm      | <b>AZ46</b>        |               | <b>06</b>               | $\phi 6$  |                          | ●        | ●        | ●        |             |          |           |           |           |           |  |
|                    |            | <b>AZ48</b>        | <b>MCV19</b>  | <b>08</b>               | $\phi 8$  |                          |          | ●        | ●        | ●           |          |           |           |           |           |  |
|                    | 60 mm      | <b>AZ66, AZ69</b>  | <b>MCV25</b>  | <b>10</b>               | $\phi 10$ |                          |          |          | ●        | ●           | ●        | ●         |           |           |           |  |
|                    | 85 mm      | <b>AZ98, AZ911</b> | <b>MCV30</b>  | <b>14</b>               | $\phi 14$ |                          |          |          |          |             | ●        | ●         | ●         | ●         |           |  |

● The applicable product name includes the characters that can distinguish the product name.

# MCS Couplings

This is a three piece structure coupling comprised of aluminium alloy hubs and resin spiders.



## Product Line

Product Name

**MCS20**

**MCS30**

**MCS40**

**MCS55**

**MCS65**

● A number indicating the coupling inner diameter is entered where the box  is located within the product name.

## Product Number Code

# MCS 30 10 12

①      ②      ③      ④

|   |   |
|---|---|
| ① | <b>MCS</b> Couplings  |
| ② | Outer Diameter of Coupling  |
| ③ | Inner Diameter d1 (smaller inner diameter)<br>( <b>FO4</b> represents $\phi 6.35$ mm) |
| ④ | Inner Diameter d2 (larger inner diameter)<br>( <b>FO4</b> represents $\phi 6.35$ mm)  |

● For inner diameter d1, the smaller of the motor shaft diameter or the driven shaft diameter is entered.  
For inner diameter d2, the larger of the motor shaft diameter or the driven shaft diameter is entered.

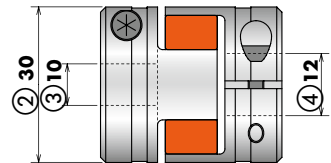

## Coupling Selection Table

- Coupling is selected based on the following content.
  - The motor output torque is within the generic torque for coupling.
  - Motor shaft diameter
- When using the parallel key, choose an appropriate coupling for the parallel key.

| Applicable Product   |   |   | Gear Ratio          | Coupling Type | Motor Shaft Diameter mm | Driven Shaft Diameter mm |          |             |          |           |           |           |           |           |           |           |           |           |           |   |   |   |   |
|----------------------|---|---|---------------------|---------------|-------------------------|--------------------------|----------|-------------|----------|-----------|-----------|-----------|-----------|-----------|-----------|-----------|-----------|-----------|-----------|---|---|---|---|
| Type                 | Frame Size                              | Product Name                            |                     |               |                         | 05                       | 06       | FO4         | 08       | 10        | 12        | 14        | 15        | 16        | 18        | 20        | 22        | 24        | 25        |   |   |   |   |
|                      |   |   |                     |               |                         | $\phi 5$                 | $\phi 6$ | $\phi 6.35$ | $\phi 8$ | $\phi 10$ | $\phi 12$ | $\phi 14$ | $\phi 15$ | $\phi 16$ | $\phi 18$ | $\phi 20$ | $\phi 22$ | $\phi 24$ | $\phi 25$ |   |   |   |   |
| TS Geared Type       | 42 mm                                   | <b>AZ46-TS</b> <input type="checkbox"/> | 3.6, 7.2            | <b>MCS20</b>  | 06                      | $\phi 6$                 | ●        | ●           | ●        | ●         | ●         |           |           |           |           |           |           |           |           |   |   |   |   |
|                      |   |   | 10, 20, 30          | <b>MCS30</b>  |                         |                          |          | ●           | ●        | ●         | ●         | ●         | ●         | ●         |           |           |           |           |           |   |   |   |   |
|                      | 60 mm                                   | <b>AZ66-TS</b> <input type="checkbox"/> | 3.6, 7.2            | <b>MCS30</b>  | 10                      | $\phi 10$                |          | ●           | ●        | ●         | ●         | ●         | ●         | ●         |           |           |           |           |           |   |   |   |   |
|                      |   |   | 10, 20, 30          | <b>MCS40</b>  |                         |                          |          |             |          | ●         | ●         | ●         | ●         | ●         | ●         | ●         |           |           |           |   |   |   |   |
| 90 mm                | <b>AZ98-TS</b> <input type="checkbox"/> |   | 3.6, 7.2, 10        | <b>MCS55</b>  | 18                      | $\phi 18$                |          |             |          |           | ●         | ●         | ●         | ●         | ●         | ●         | ●         | ●         | ●         | ● | ● | ● |   |
|                      |   |   | 20, 30              | <b>MCS65</b>  |                         |                          |          |             |          |           |           |           |           | ●         | ●         | ●         | ●         | ●         | ●         | ● | ● | ● | ● |
| FC Geared Type       | 42 mm                                   | <b>AZ46-FC</b> <input type="checkbox"/> | 7.2, 10, 25, 36, 50 | <b>MCS20</b>  | 10                      | $\phi 10$                | ●        | ●           | ●        | ●         | ●         |           |           |           |           |           |           |           |           |   |   |   |   |
|                      |   |   |                     | <b>MCS30</b>  |                         |                          |          |             |          |           | ●         | ●         | ●         | ●         |           |           |           |           |           |   |   |   |   |
|                      | 60 mm                                   | <b>AZ66-FC</b> <input type="checkbox"/> |                     | <b>MCS40</b>  | 15                      | $\phi 15$                |          |             |          | ●         | ●         | ●         |           |           |           |           |           |           |           |   |   |   |   |
|                      |   |   |                     | <b>MCS55</b>  |                         |                          |          |             |          |           | ●         | ●         |           |           |           | ●         |           |           |           |   |   |   |   |
| PS Geared Type       | 42 mm                                   | <b>AZ46-PS</b> <input type="checkbox"/> | 5                   | <b>MCS20</b>  | 10                      | $\phi 10$                | ●        | ●           | ●        | ●         | ●         |           |           |           |           |           |           |           |           |   |   |   |   |
|                      |   |   | 7.2, 10, 25, 36, 50 | <b>MCS30</b>  |                         |                          |          | ●           | ●        | ●         | ●         | ●         | ●         | ●         |           |           |           |           |           |   |   |   |   |
|                      | 60 mm                                   | <b>AZ66-PS</b> <input type="checkbox"/> | 5, 7.2              | <b>MCS40</b>  | 12                      | $\phi 12$                |          |             |          | ●         | ●         | ●         | ●         | ●         | ●         | ●         | ●         | ●         | ●         | ● | ● | ● |   |
|                      |   |   | 10, 25, 36, 50      | <b>MCS55</b>  |                         |                          |          |             |          |           | ●         | ●         | ●         | ●         | ●         | ●         | ●         | ●         | ●         | ● | ● | ● | ● |
| 90 mm                | <b>AZ98-PS</b> <input type="checkbox"/> |   | 5, 7.2              | <b>MCS55</b>  | 18                      | $\phi 18$                |          |             |          |           | ●         | ●         | ●         | ●         | ●         | ●         | ●         | ●         | ●         | ● | ● |   |   |
|                      |   |   | 10, 25, 36, 50      | <b>MCS65</b>  |                         |                          |          |             |          |           |           |           |           | ●         | ●         | ●         | ●         | ●         | ●         | ● | ● | ● | ● |
| HPG Geared Type      | 40 mm                                   | <b>AZ46-HP</b> <input type="checkbox"/> | 5, 9                | <b>MCS30</b>  | 10                      | $\phi 10$                |          | ●           | ●        | ●         | ●         | ●         | ●         | ●         |           |           |           |           |           |   |   |   |   |
|                      | 60 mm                                   | <b>AZ66-HP</b> <input type="checkbox"/> | 5, 15               | <b>MCS55</b>  | 16                      | $\phi 16$                |          |             |          |           | ●         | ●         |           |           |           | ●         |           |           |           |   |   |   |   |
|                      | 90 mm                                   | <b>AZ98-HP</b> <input type="checkbox"/> | 5, 15               | <b>MCS65</b>  | 25                      | $\phi 25$                |          |             |          |           |           |           |           |           |           | ●         | ●         |           |           |   |   |   |   |
| Harmonic Geared Type | 42 mm                                   | <b>AZ46-HS</b> <input type="checkbox"/> | 50, 100             | <b>MCS40</b>  | 10                      | $\phi 10$                |          |             | ●        | ●         | ●         | ●         | ●         | ●         | ●         | ●         | ●         | ●         | ●         | ● | ● | ● |   |
|                      | 60 mm                                   | <b>AZ66-HS</b> <input type="checkbox"/> | 50, 100             | <b>MCS55</b>  | 15                      | $\phi 15$                |          |             |          |           | ●         | ●         |           |           |           | ●         |           |           |           |   |   |   |   |

- The applicable product name includes the characters that can distinguish the product name.
- The  within the product name includes a number expressing the reduction ratio.

# Motor Mounting Brackets

Mounting brackets are convenient for installation and securing a stepping motor and geared stepping motor. The attachment fitting fixing section is a convenient long hole specification for adjusting belt tension after assembling the motor.



## Product Line

### Standard Type

Material: Aluminum Alloy (SPCC)\*  
Surface processing: paint (electroless nickel plating)\*

| Product Name   | Motor Frame Size | Applicable Product |
|----------------|------------------|--------------------|
| <b>PFB28A</b>  | 28 mm            | <b>AZ24, AZ26</b>  |
| <b>PAFOP</b>   | 42 mm            | <b>AZ46, AZ48</b>  |
| <b>PALOP</b>   |                  |                    |
| <b>PAL2P-5</b> | 60 mm            | <b>AZ66, AZ69</b>  |
| <b>PAL4P-5</b> | 85 mm            | <b>AZ98, AZ911</b> |

- \*The **PFB28A** specification is indicated within ( ).
- These mounting brackets can be perfectly fitted to the pilot of the stepping motors. (Except for **PALOP**)
  - There is a motor attachment screw attached.

### TS Geared Type

Material: Aluminum Alloy  
Surface processing: painting

| Product Name  | Motor Frame Size | Applicable Product |
|---------------|------------------|--------------------|
| <b>SOL0B</b>  | 42 mm            | <b>AZ46</b>        |
| <b>SOL2M4</b> | 60 mm            | <b>AZ66</b>        |
| <b>SOL5M8</b> | 90 mm            | <b>AZ98</b>        |

### PS Geared Type

Material: SS400  
Surface processing: electroless nickel plating

| Product Name  | Motor Frame Size | Applicable Product |
|---------------|------------------|--------------------|
| <b>PLA60G</b> | 60 mm            | <b>AZ66</b>        |
| <b>PLA90G</b> | 90 mm            | <b>AZ98</b>        |

- There is a motor attachment screw attached.

### Harmonic Geared Type

Material: SS400  
Surface processing: electroless nickel plating

| Product Name  | Motor Frame Size | Applicable Product |
|---------------|------------------|--------------------|
| <b>PLA60H</b> | 60 mm            | <b>AZ66</b>        |
| <b>PLA90H</b> | 90 mm            | <b>AZ98</b>        |

- There is a motor attachment screw attached.

## Motor Mounting Direction

The motor cable comes out at right angles to the motor. Orient the motor so that the cable faces either upward or sideways.

- For **PLA60G, PLA90G, PLA60H, PLA90H**: The cable can face downward.

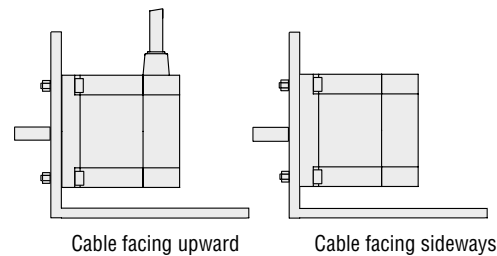

## How to mount the motor

### 1 PAL2P-5, SOL2M4 PAL4P-5, SOL5M8

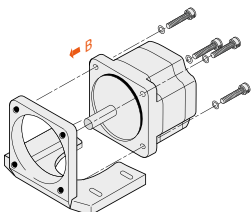

- ① Use the screws provided to secure the motor to the mounting bracket.
- ② Attach the motor from the direction shown by the arrow (B).

### 2 PALOP, SOL0B

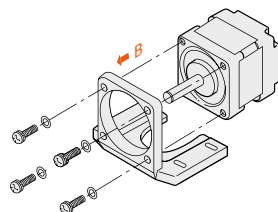

- ① Use the screws provided to secure the motor to the mounting bracket.
- ② Attach the motor from the direction shown by the arrow (B).

### 3 PAFOP, PFB28A

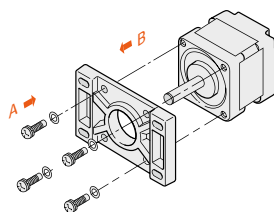

- ① Use the screws provided to secure the motor to the mounting bracket.
- ② Attach motor from the direction shown by either arrow (A) or arrow (B).

### 4 PLA60G, PLA60H PLA90G, PLA90H

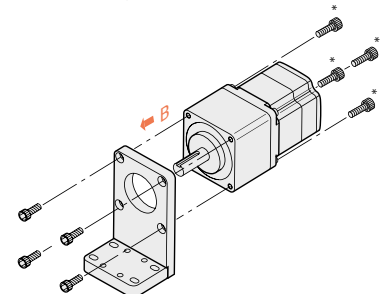

- ① Use the screw to attach the motor to the attachment fitting.
- ② Attach the motor from the direction shown by the arrow (B).  
\* Motor mounting hole on **PLA90H** is processed with tapping. Insert the screw from direction B.

## Dimensions (Unit = mm)

### PFB28A

Mass: 25 g

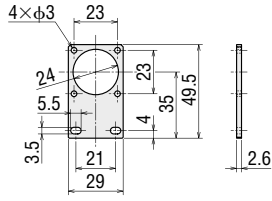

- Mounting Screws: M2.5 Length 5 mm  
Included 4 pieces

### PAFOP

Mass: 30 g

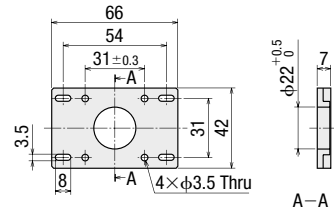

- Mounting Screws: M3 Length 7 mm  
Included 4 pieces

### PALOP

Mass: 35 g

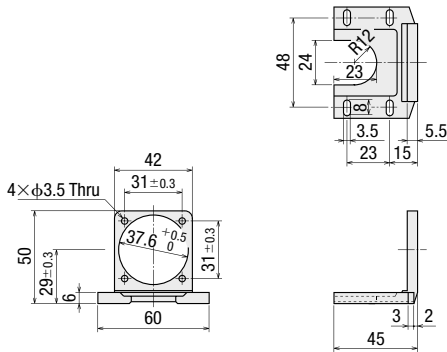

- Mounting Screws: M3 Length 10 mm  
Included 4 pieces

### PAL2P-5

Mass: 110 g

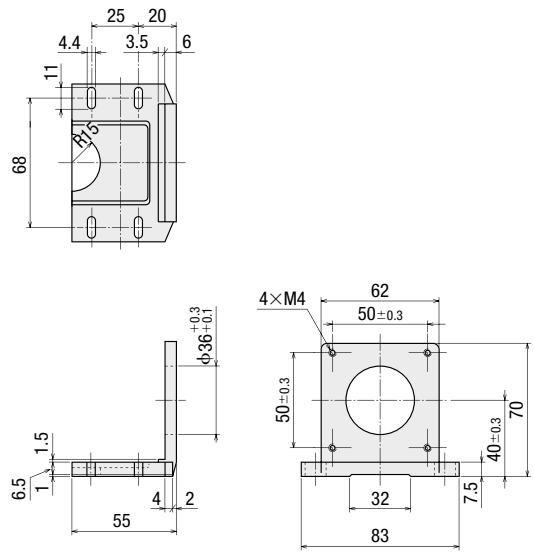

- Mounting Screws: M4 Length 12 mm  
Included 4 pieces

### PAL4P-5

Mass: 250 g

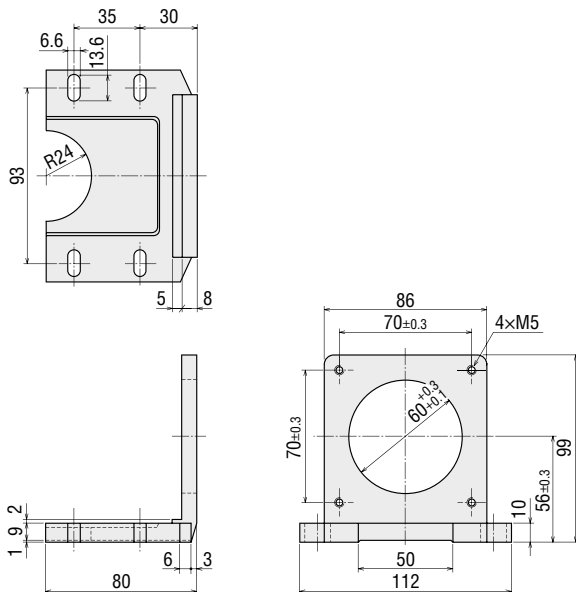

- Mounting Screws: M5 Length 16 mm  
Included 4 pieces

### SOLOB

Mass: 85 g

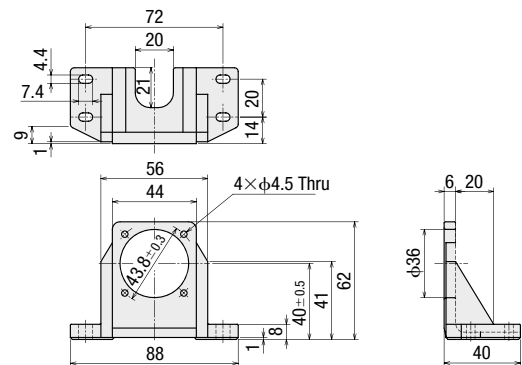

### SOL2M4

Mass: 135 g

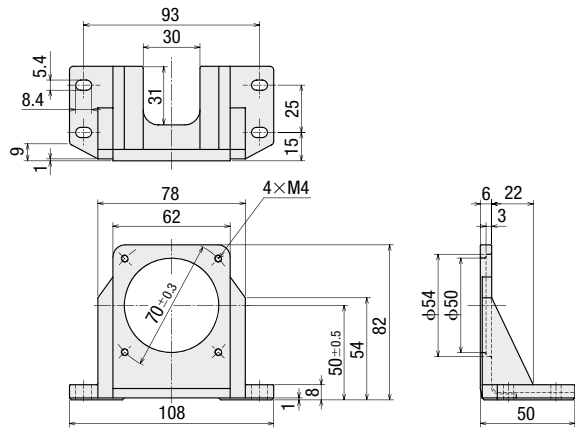

### SOL5M8

Mass: 270 g

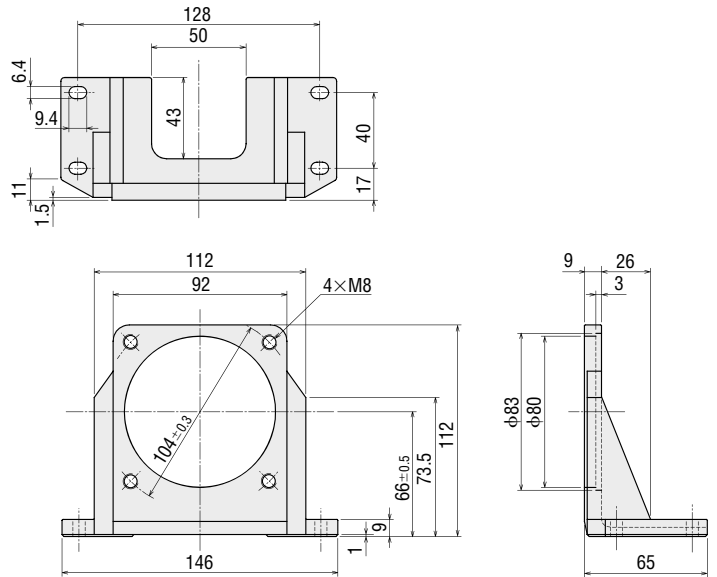

### PLA60G

Mass: 0.7 kg

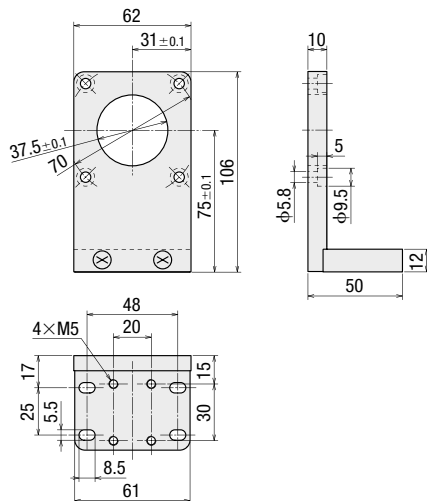

● Mounting Screws: M5 Length 15 mm  
Included 4 pieces

### PLA60H

Mass: 0.7 kg

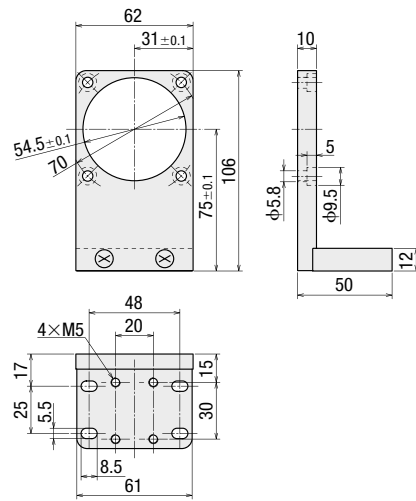

● Mounting Screws: M5 Length 15 mm  
Included 4 pieces

### PLA90G

Mass: 1.6 kg

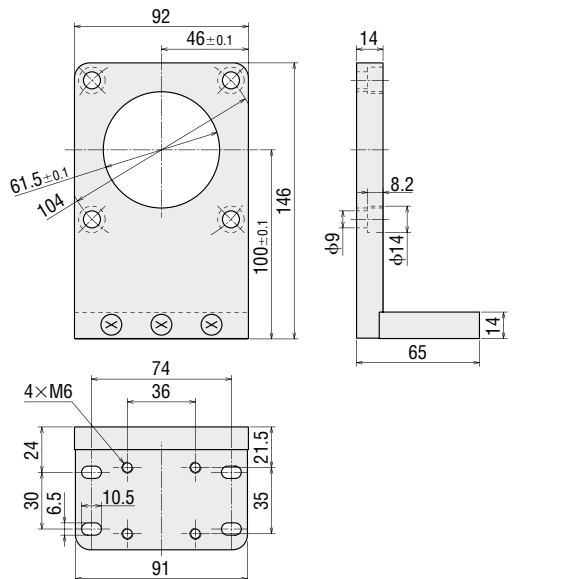

● Mounting Screws: M8 Length 20 mm  
Included 4 pieces

### PLA90H

Mass: 1.6 kg

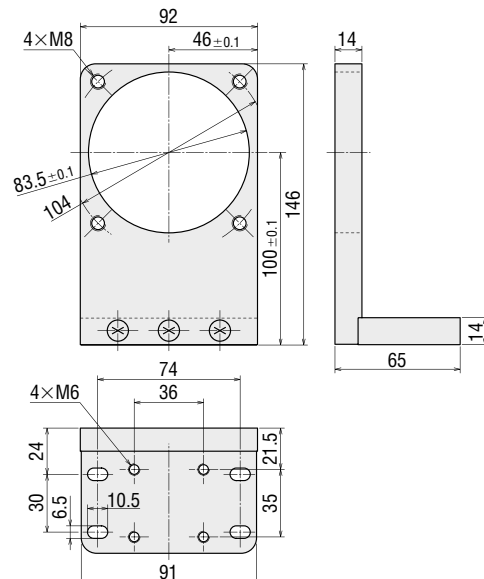

● Mounting Screws: M8 Length 30 mm  
Included 4 pieces, 4 washers

|                             |
|-----------------------------|
| Features                    |
| System Configuration        |
| Product Line                |
| Specifications and Features |
| Dimensions                  |
| Connection and Operation    |
| System Configuration        |
| Product Line                |
| Specifications and Features |
| Dimensions                  |
| Connection and Operation    |
| Multiaxis Driver            |

### Accessories

# Regeneration Unit

During vertical drive (gravitational operation) or sudden start/stop in high inertia, an external force causes the motor to rotate and function as a power generator. When the regenerative power exceeds the driver's regenerative power absorption capacity, it may cause damage to the motor. In such a case, the regeneration unit is connected to the driver to convert regenerative energy into thermal energy for dissipation.



## Product Line

| Product Name  | List Price |
|---------------|------------|
| <b>RGB100</b> | €41.00     |

## Specifications

| Item                             | Description   |
|----------------------------------|---|
| Continuous Regenerative Power    | 50 W  |
| Resistance Value                 | 150 Ω   |
| Thermostat Operating Temperature | Open: 150±7°C<br>Close: 145±12°C<br>(Normally closed) |
| Thermostat Electrical Rating     | 120 VAC 4 A<br>30 VDC 4 A<br>(Min. current 5 mA)      |

- Attach the regeneration unit to a location that has the same heat radiation capability as an aluminum heat radiation plate that is 350×350 mm and 3 mm thick.

# Network Converters

Network converter is a transducer from the host communication protocol to our unique RS-485 communication protocol. By using this network converter, our RS-485 compatible products can be controlled under host communication environment.

## Product Line

| Network Type                | Product Name      |
|-----------------------------|-------------------|
| CC-Link Ver. 1.1 Compatible | <b>NETC01-CC</b>  |
| CC-Link Ver. 2 Compatible   | <b>NETC02-CC</b>  |
| MECHATROLINK-II Compatible  | <b>NETC01-M2</b>  |
| MECHATROLINK-III Compatible | <b>NETC01-M3</b>  |
| EtherCAT Compatible         | <b>NETC01-ECT</b> |



# Controllers

Equipped with program editing and execution functions, the highly-functional and sophisticated **SCX11** controller is now available. Use the **SCX11** as a stored program controller to connect to any of Oriental Motor's standard pulse input drivers.

The **SCX11** is also able to control the motor via various serial ports such as USB, RS-232C and **CANopen**.

- 100 Sequence Programs can be Stored
- Easy Operation
- Intelligent Setting

## Product Line

| Product Name | Driver Product Name |
|--------------|---------------------|
| <b>SCX11</b> | AZD-C, AZD-K        |



| Features | AC Input             |              |                             |            |                          | DC Input             |              |                             |            |                          | Accessories |                  |
|----------|----------------------|--------------|-----------------------------|------------|--------------------------|----------------------|--------------|-----------------------------|------------|--------------------------|-------------|------------------|
|          | System Configuration | Product Line | Specifications and Features | Dimensions | Connection and Operation | System Configuration | Product Line | Specifications and Features | Dimensions | Connection and Operation |             | Multiaxis Driver |
|          |                      |              |                             |            |                          |                      |              |                             |            |                          |             |                  |

# Orientalmotor

These products are manufactured at plants certified with the international standards **ISO 9001** (for quality assurance) and **ISO 14001** (for systems of environmental management).

Specifications are subject to change without notice. This catalogue was published in February 2018.

## **ORIENTAL MOTOR (EUROPA) GmbH**

[www.orientalmotor.de](http://www.orientalmotor.de)

### **European Headquarters**

Schießstraße 44  
40549 Düsseldorf, Germany  
Tel: 0211-520 670 0 Fax: 0211-520 670 99



### **Spanish Office**

C/Caléndula 93 - Ed. E - Miniparc III  
28109 El Soto de La Moraleja,  
Alcobendas (Madrid), Spain  
Tel: +34 918 266 565  
[www.orientalmotor.es](http://www.orientalmotor.es)

## **ORIENTAL MOTOR (UK) LTD.**

[www.oriental-motor.co.uk](http://www.oriental-motor.co.uk)

### **UK Headquarters**

Unit 5, Faraday Office Park,  
Rankine Road, Basingstoke,  
Hampshire RG24 8AH, U.K.  
Tel: 01256-347 090 Fax: 01256-347 099



## **ORIENTAL MOTOR SWITZERLAND AG**

[www.orientalmotor.ch](http://www.orientalmotor.ch)

### **Switzerland Headquarters**

Badenerstraße 13  
5200 Brugg AG, Switzerland  
Tel: 056-560 504 5 Fax: 056-560 504 7



## **ORIENTAL MOTOR ITALIA s.r.l.**

[www.orientalmotor.it](http://www.orientalmotor.it)

### **Italy Headquarters**

Via XXV Aprile 5  
20016 Pero (MI), Italy  
Tel: 02-939 063 46 Fax: 02-939 063 48



## **ORIENTAL MOTOR (FRANCE) SARL**

[www.orientalmotor.fr](http://www.orientalmotor.fr)

### **France Headquarters**

56, Rue des Hautes Pâtures  
92000 Nanterre, France  
Tel: 01-478 697 50 Fax: 01-478 245 16



**Other countries:** [www.orientalmotor.eu](http://www.orientalmotor.eu)

## **Customer Service Center (Support in German & English)**

00800-22 55 66 22\*  
CA LL OM CC

Mon-Thu: 08:00 - 17:30 CET Friday: 08:00 - 16:00 CET

\* Free Call Europe

[info@orientalmotor.de](mailto:info@orientalmotor.de)

For more information please contact: